

# D'ANDREA®

TECHNOLOGY FOR HIGH PRECISION



2018

Made in Italy

# TOOLS

Toolholders  
Werkzeugaufnahmen  
Portaherramientas  
Porte-outils  
Portautensili



10  
MODULHARD'



138  
PSC Linea



176  
MONOforce



184  
TOPRUN



192  
MONOd'



210  
MONOd' CT



224  
MCD'

238  
ACCESSORIES

246  
TECHNICAL DATA

# HEADS

Boring and facing heads  
Plandreh-und ausbohrköpfe  
Cabezales de mandrinar y refrentar  
Tetes a alesar et surface  
Teste per alesare e sfacciare



254  
U-TRONIC



268  
TA-CENTER



278  
TA-TRONIC



288  
U-COMAX



296  
AUTORADIAL

# modulhard'andrea MHD'

## ARBORS

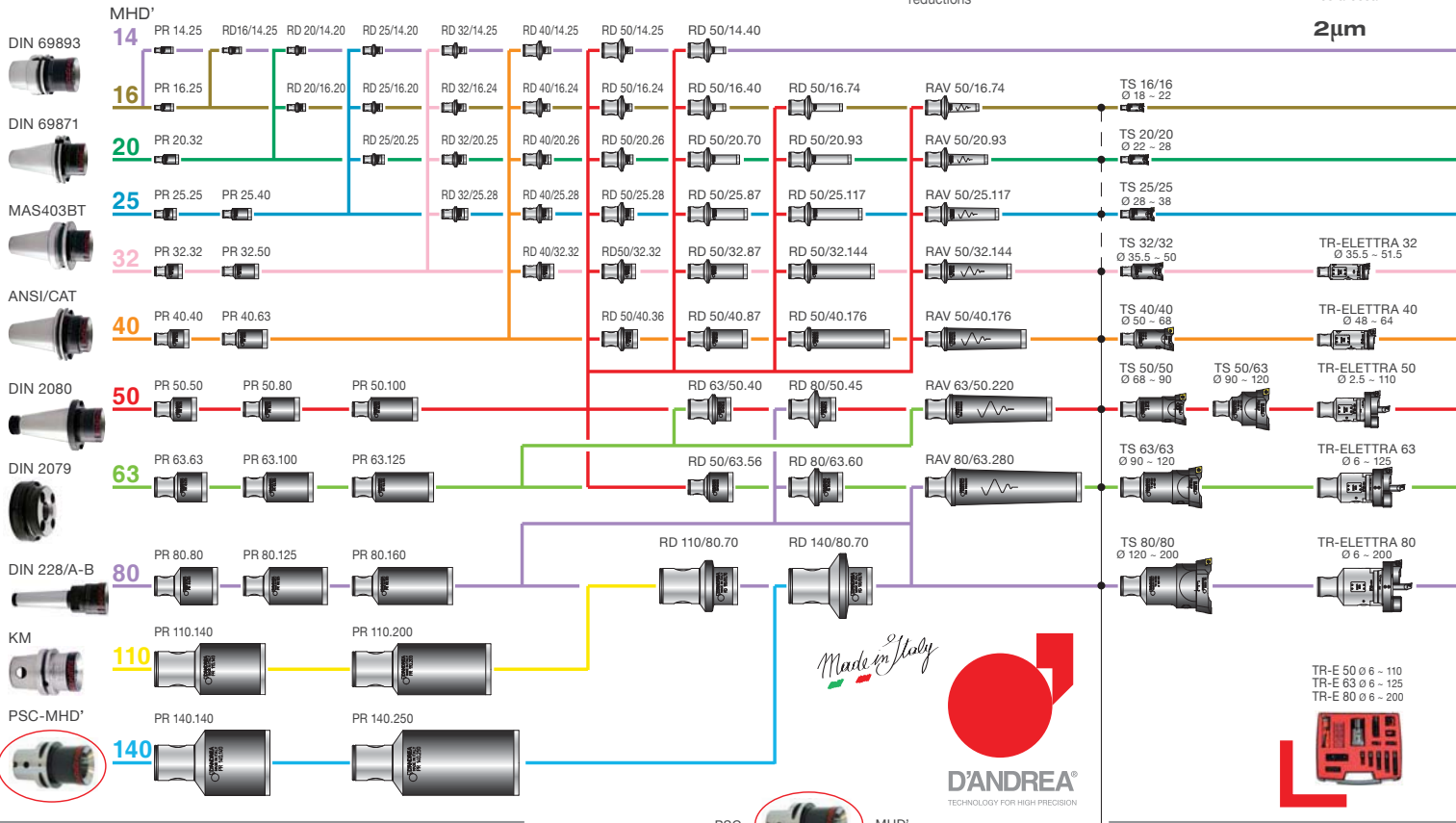
### PR Extensions

### RD Reductions

### RAV Vibration-damping reductions

### TS Double-bit heads

### TR-E Micrometric Digital Testarossa



## Modular PSC Linea

## ARBORS

### PR Extensions

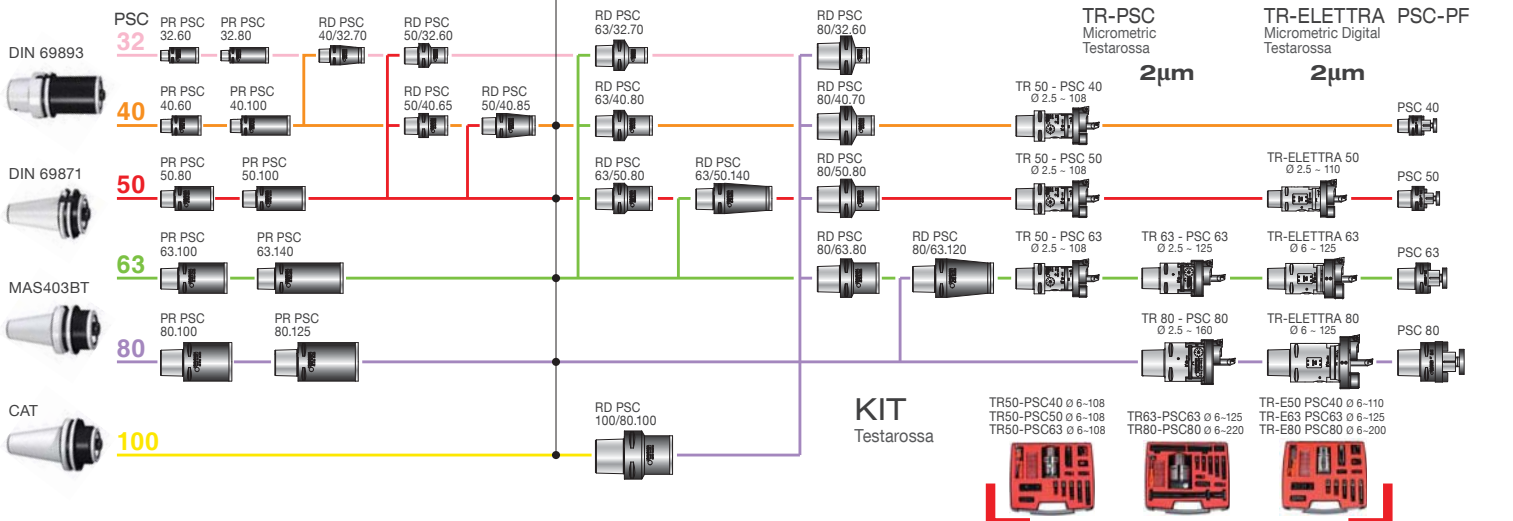
### RD Reductions

## testarossad'andrea

### TR-PSC Micrometric Testarossa

### TR-ELETTTRA Micrometric Digital Testarossa

### PSC-PF



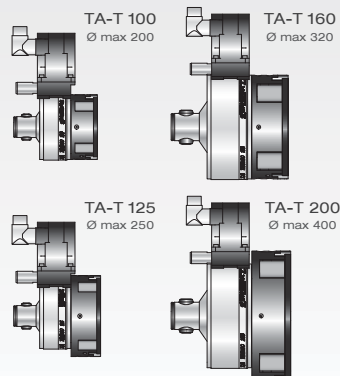
## TA-CENTER

NC boring and facing heads with automatic balancing suitable for ATC handling



## TA-TRONIC

NC boring and facing heads with automatic balancing



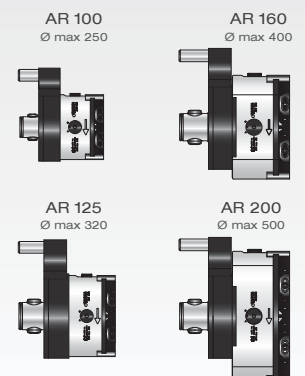
## U-COMAX

Axial control NC boring and facing heads for transfer machines



## AUTORADIAL

Automatic facing heads











Marino D'Andrea, the founder  
Marino D'Andrea, il fondatore



The first boring and facing head  
La prima testa per sfacciare e alesare



Golden Compass  
award for industrial design



The first D'Andrea logo type (1961)  
Il primo logo tipo di D'Andrea (1961)

- Quality, Experience, Technology, High precision, Innovation, Professional skills are the strongest points that made the firm and the whole D'Andrea production winning on the Italian and the worldwide market.
- Qualità, Esperienza, Tecnologia, Alta precisione, Innovazione, Competenza, sono i punti di forza che hanno reso vincente l'azienda e tutta la produzione D'Andrea sul mercato nazionale ed internazionale.



• A tradition going back over 50 years in the field and a big passion for mechanics have been allowing D'Andrea to go on strengthening its position on domestic and international markets over the years. D'Andrea now has a 30% share of the market for modular systems and a 10% share of the entire toolholders sector (including modular systems), at the top in its sector in Italy. D'Andrea is internationally prominent in the field of large diameters precision boring.

• Una tradizione con più di 50 anni di attività nel settore e una grande passione per la meccanica hanno fatto sì che, nel corso degli anni, D'Andrea consolidasse sempre di più la sua posizione sul mercato nazionale ed internazionale. Attualmente D'Andrea detiene il 30% della quota di mercato dei sistemi modulari e il 10% nell'intero settore dei portautensili (comprensivo anche dei modulari) posizionandosi come leader nazionale. A livello internazionale, D'Andrea detiene la posizione di leadership nell'alesatura di precisione dei grandi diametri.

- D'Andrea S.p.A. is a world leader in the field of accessories for machine tools. Boring and facing heads and toolholders are all made in the factory in Lainate (Milan). Components of toolholders systems are produced in the plant in Castel Del Giudice (Isernia).

- D'Andrea S.p.A. è leader mondiale nel settore degli accessori per macchine utensili. La progettazione e la produzione di teste per alesare e sfacciare e di portautensili avviene interamente nella sede di Lainate (Milano). I componenti dei sistemi di portautensili vengono realizzati nello stabilimento di Castel Del Giudice (Isernia).

D'Andrea headquarters in Lainate (Milan)  
La sede D'Andrea a Lainate (Milano)



The company respects a Quality Certified System in compliance with UNI EN ISO 9001

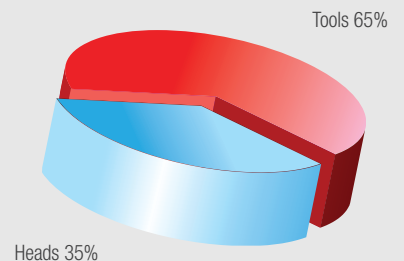
- D'Andrea boasts a functional, modern and productive facility with over 7000 sq.m. of workshops, executive offices, design department and training spaces and it relies on the cooperation of about 110 employees at the Lainate (Milan) plant. The Castel del Giudice (Isernia) plant is over 1300 sq.m. and has around 30 employees.

- D'Andrea vanta una struttura produttiva moderna e funzionale di oltre 7.000 mq di officine, uffici direzionali, ufficio tecnico e spazi per la formazione, che conta sulla collaborazione di circa 110 dipendenti nella sede di Lainate (Milano). Lo stabilimento di Castel Del Giudice (Isernia) è di oltre 1300 mq con circa 30 dipendenti.



Show Room D'Andrea Lainate (Milano)

The manufacturing plant in Castel Del Giudice (Isernia)  
Lo stabilimento di Castel Del Giudice (Isernia)







- D'Andrea is a company with an all round approach to management that takes into account the latest trends and developments on the domestic and international market. At the same time, the company has a widespread distribution network offering the right amount of flexibility, to satisfy the local market requirements.

- D'Andrea è un'azienda che adotta una politica gestionale a 360° che tiene conto delle tendenze ed evoluzioni del mercato nazionale e mondiale. Nello stesso tempo, la presenza di una rete di distribuzione capillare conferisce all'azienda il giusto grado di flessibilità per agire e rispondere efficientemente alle richieste locali del mercato.

- D'Andrea guarantees a customized technical consulting service and a permanent repair service of the products sold over the world.

- D'Andrea garantisce un servizio personalizzato di consulenza tecnica e un servizio permanente di riparazione dei prodotti in ogni parte del mondo.



- D'Andrea combines the attentive technical assistance with an intense training activity for its Italian and foreign distributors. D'Andrea tutors periodically hold training courses in order to show the main technical features and working principles of the whole product range.

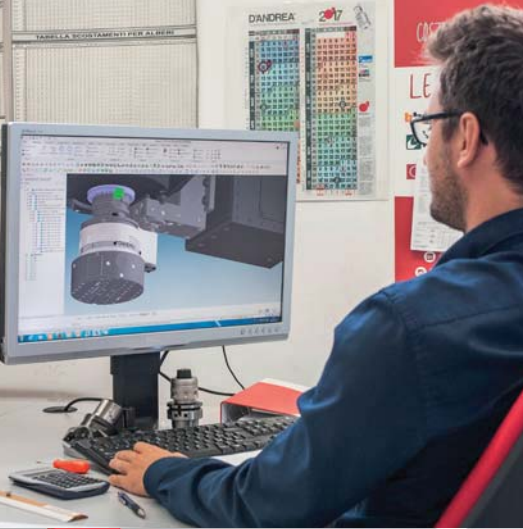
- D'Andrea integra l'attento servizio di assistenza tecnica con un'intensa attività di formazione rivolta ai propri distributori, italiani e stranieri. Tecnici specializzati tengono periodicamente corsi di aggiornamento allo scopo di illustrare le caratteristiche tecniche e i principi di funzionamento dell'intera gamma di prodotti.





- The Sales Department manages business all over the world.

- L'Ufficio Commerciale gestisce le vendite in tutto il mondo.



- D'Andrea gained a position of prominence world-wide thanks to its unequalled know-how. The company invests massively in Research and Development to keep up with the times. A team of highly skilled design engineers is continually researching advanced technological solutions, developing new products according to market requirements and executing special designs based on specific customer requests.

- D'Andrea ha acquisito una fama mondiale per il suo know how senza pari. Per mantenersi al passo coi tempi l'azienda investe ingenti risorse nel comparto Ricerca e Sviluppo. Un efficiente team di progettisti è continuamente alla ricerca di soluzioni tecnologiche avanzate, sviluppa nuovi prodotti assecondando le richieste del mercato ed è in grado di eseguire progetti speciali su richiesta specifica del cliente.



- The company understands customers' specific needs and responds with the most appropriate solutions.

- L'azienda comprende le specifiche esigenze del cliente ed è in grado di soddisfarle con le soluzioni più adatte.





MODULHARD'



PSC Linea



MONOforce



TOPRUN



MONOd'



MONOd' CT



MCD'

TOOLS

the power of precision

- 
- GB** High precision modular toolholders that allow boring, milling, drilling, and tapping operations to be carried out with extreme flexibility and rigidity.
  - D** Modulare Hochpräzisions-Werkzeughalter für Werkzeugmaschinen und Bearbeitungszentren, die mit extremer Flexibilität und Starre Ausbohr-, Fräs-, Bohr-, und Gewindebohrarbeiten ermöglichen.
  - E** Portaherramientas modulares de alta precisión que permiten efectuar con extrema flexibilidad y rigidez, operaciones de mandrinado, fresado, taladrado y roscado.
  - F** Porte-outils modulaires de haute précision permettant d'exécuter grâce à leur extrême flexibilité et rigidité, des opérations d'alésage, fraisage, forage et taraudage.
  - I** Portautensili modulari di alta precisione che consentono di eseguire con estrema flessibilità e rigidità, operazioni di alesatura, fresatura, foratura e maschiatura.

- 
- GB** High precision ultra-tight toolholder with 12, 20 and 32 mm diameter tool arbor.
  - D** Präzisionswerkzeughalter mit hochfester Aufspannung mit einem Durchmesser von 12, 20 und 32 mm.
  - E** Portaherramientas de precisión de gran apriete con unión herramienta de diámetro 12, 20 y 32 mm.
  - F** Porte-outils de précision à serrage fort prévoyant des dimensions de logement de l'outil de 12, 20 et 32 mm de diamètre.
  - I** Portautensili di precisione a forte serraggio con attacco utensile diametro 12, 20 e 32 mm.

- 
- GB** High precision balanceable monoblock toolholder for high-speed machining.
  - D** Auswuchtbare Monoblock-Werkzeughalter für Hochpräzision und Hochgeschwindigkeitsbearbeitung.
  - E** Portaherramientas monobloc equilibrables de elevada precisión para elaboraciones de alta velocidad
  - F** Porte-outils monobloc équilibrable de haute précision pour les usinages à grande vitesse.
  - I** Portautensili monoblocco bilanciabili di elevata precisione per lavorazioni ad alta velocità.

- 
- GB** Integrated high quality toolholders, ideal for all types of machine tool equipment with HSK, DIN and BT base arbors.
  - D** Die integrierten Werkzeughalter von herausragender Qualität stellen die ideale Lösung für die Ausrüstung aller Arten von Werkzeugmaschinen mit Basisanschluss HSK, DIN und BT dar.
  - E** Portaherramientas integrales de elevada calidad, ideales para equipar cualquier tipo de máquina herramienta con unión base HSK, DIN y BT.
  - F** Porte-outils intégraux de haute qualité représentant la solution idéale pour équiper tous les types de machines-outils avec une fixation de base HSK, DIN et BT.
  - I** Portautensili integrali di elevata qualità, ideali per attrezzare ogni tipo di macchina utensile con attacco base HSK, DIN e BT.

- 
- GB** High quality shrink fit integral tool holders, ideal for equipping any type of machine tool with basic HSK, PSC, DIN, and BT attachment.
  - D** Hochwertiger Schrumpf-Werkzeughalter ideal zur Ausstattung jeder Art von Werkzeugmaschinen mit Basissockel HSK, PSC, DIN und BT.
  - E** Portaherramientas integrales con acoplamiento térmico de elevada calidad, ideal para equipar cualquier tipo de máquina herramienta con conexión base HSK, PSC, DIN y BT.
  - F** Porte-outils intégraux de haute qualité, à frettage thermique, aptes à équiper toute machine-outil munie d'attachement de base HSK, PSC, DIN et BT.
  - I** Portautensili integrali a Calettamento Termico di elevata qualità, ideali per attrezzare ogni tipo di macchina utensile con attacco base HSK, PSC, DIN e BT.

- 
- GB** Lathe toolholder program, recommended for the application on MULTI-TASK machines
  - D** Das Werkzeughalterprogramm für Drehmaschinen, das für die Anbringung auf den Spindeln von MULTI-TASK-Maschinen empfohlen wird.
  - E** Programa de portaherramientas de torno recomendado para la aplicación en máquinas MULTI-TASK.
  - F** Programme de porte-outils pour le tour, recommandé pour l'application sur les machines MULTI-TASK.
  - I** Programma di portautensili da tornio, raccomandato per l'applicazione su macchine MULTI-TASK.

---

*Made in Italy*





*Modularity  
and high precision*





- ARBORS
- GRUNDAUFNAHMEN
- ACOPLAMIENTOS BASE
- MANDRINS
- ATTACCHI BASE

- EXTENSIONS REDUCTIONS AND COOLANT FEED
- VERLÄNGERUNGEN, REDUZIERUNGEN UND KÜHLMITTELZUFUHR
- PROLONGACIONES REDUCCIONES Y CONDUCTORES PARA REFRIGERANTE
- RALLONGES-RÉDUCTIONS ET ADDUCTEURS ARROSAGE
- PROLUNGHE RIDUZIONI E ADDUTTORI REFRIGERANTE

- DOUBLE-BIT HEADS
- ZWEISCHNEIDERBOHRKÖPFE
- CABEZALES DE DOS CUCHILLAS
- TÊTES À DOUBLE TRANCHANT
- TESTINE BITAGLIENTI

p.240 • RFR



p.17-18 • HSK DIN 69893



p.28 • BR



p.36-41 • TS . .  
Ø 18 ~ 200



p.240 • TNT



p.40-41 • SS . .



p.19 • ISO 26623-1 PSC



p.19 • ISO 26622-1 KM



p.29 • BMD



p.41 • PT



p.20 • DIN 69871 FC  
FACE CONTACT



p.21 • MAS 403 BT FC  
FACE CONTACT



p.30 • PR



p.50-54-58-66-96 • PS 31  
p.100-104



p.22-23 • DIN 69871



p.24-25 • MAS 403 BT



p.31 • RD



p.50-54-58-66-96 • CW 32  
p.100-104



p.51-55-59-67-97 • P25



p.55-59-101-105 • P22



p.26 • ANSI/CAT



p.26 • DIN 2080



p.31 • RD



p.69-73 • P20.30



p.27 • ISO 50/60 D.60



p.27 • DIN 228/A 2207



p.32 • RD



p.70-74-78 • PS



p.27 • DIN 228/B 1806



p.27 • R8



p.32 • RAV



p.71-75-77 • P



p.49-53-57-65-69-73 • B. .  
p.95-99-103-109-111



p.28 • MR



p.28 • DIN 2079



p.33 • BLC



p.241 • KIT K20.50  
Ø 6 ~ 30





• TESTAROSSA

p.44-46 • **TR-E32 MHD'32**  
Ø 35.5-51.5



p.47 • **TR-E40 MHD'40**  
Ø 48-64



p.48-51 • **TR-E50 MHD'50**  
Ø 2.5-110



• **KIT K00** Ø 6 ~ 22  
• **KIT K01** Ø 6 ~ 110



p.52-55 • **TR-E63 MHD'63**  
Ø 6 ~ 125



• **KIT K01**  
Ø 6 ~ 125



p.56-59 • **TR-E80 MHD'80**  
Ø 6 ~ 200



• **KIT K01**  
Ø 6 ~ 200



p.60-63 • **TRM 16-40**  
Ø 18 ~ 63



• **SF..**  
p.61

p.64-67 • **TRM 50**  
Ø 2.5 ~ 108



• **KIT K00** Ø 6 ~ 22  
• **KIT K01** Ø 6 ~ 108



p.68-71 • **TRM 50/63**  
• **TRM 63/63**  
Ø 2.5 ~ 125



• **KIT K01**  
Ø 6 ~ 125



p.72-75 • **TRM 50/80**  
• **TRM 80/80**  
Ø 2.5 ~ 160



• **KIT K01**  
Ø 6 ~ 220



p.76-79 • **TRM 80/125**  
Ø 36 ~ 500



• **KIT K03**  
Ø 36 ~ 410



p.51-55-59-67-71  
p.75-79-97-101-105

• **SF..**



p.80-85 • **BPS . . . .**  
Ø 200 ~ 2700



p.86 • **TR 200**  
Ø200-2700



p.86 • **TR-E 200**  
Ø200-2700



p.87 • **SF..**



p.87 • **SS-SM..**



p.87 • **CW**



p.87 • **PRL**



p.88 • **TP**



p.88 • **PC**



p.89 • **TU**



p.89 • **AS..45°**



p.116-117 • **INSERT . . . .**



p.118-119 • **INFO**



p.253 • **Win Tool**

p.90-93 • **TRC 14-40**  
Ø 14.5 ~ 66



p.93 • **SF..**

p.94-97 • **TRC 50**  
Ø 2.5-110



• **KIT K00**  
Ø 6 ~ 22



• **KIT K01**  
Ø 6 ~ 110



p.98-101 • **TRC 63**  
Ø 6 ~ 125



• **KIT K01**  
Ø 6 ~ 125



p.102-105 • **TRC 80**  
Ø 6 ~ 125



• **KIT K01**  
Ø 6 ~ 200



p.97-101-105

• **SF..**



p.106-109 • **TRC 32 HS**  
Ø 2.5 ~ 18



• **KIT K01**  
Ø 2.5 ~ 12



p.106-109 • **TRM 32 HSB**  
Ø 2.5 ~ 18



• **KIT K01**  
Ø 2.5 ~ 12



p.110-111 • **TRC 50 HS**  
Ø 2.5 ~ 22



• **KIT K01**  
Ø 6 ~ 22



p.110-111 • **TRM 50 HSB**  
Ø 2.5 ~ 22



• **KIT K01**  
Ø 6 ~ 22



p.112-115 • **TRD 25-80**  
Ø 28 ~ 120



• **SS.. - SF..**



p.115 • **SS.. - SF..**

- CHUCKING TOOLS
- ADAPTER
- ADAPTADORES
- ADAPTATEURS
- ADATTATORI

p.130 • **PE**



p.130 • **MHD FORCE**



p.131 • **AW**



p.132 • **PF**



p.133 • **CM**



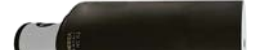
p.134 • **AM**



p.134 • **B16**



p.134 • **NS**



p.135 • **ACR/NC**



p.135 • **ACR**



# D'ANDREA MODULHARD'ANDREA

- WHAT IS MHD'?
- WAS IST DAS MHD'?
- ¿QUÉ ES EL MHD'?
- QU'EST-CE QUE LE MHD'?
- COS'È L'MHD'?



**GB** High precision modular toolholders for machine tools and machining centers that allow boring, milling, drilling, and tapping operations to be carried out with extreme flexibility and rigidity. The cylindrical-conical coupling comes in eleven, sizes, ensuring the interchangeability of all the elements of the system that includes the base arbors HSK, DIN, BT, CAT and Polygon-shank, toolholder extensions, reductions, and adapters. The broad boring program for machining diameters from 2.5 to 2700 mm completes the MHD' line with roughing double-bit heads and centesimal and micrometric Testarossa finishing heads with a 2µm sensitivity adjustment.

**D** Modulare Hochpräzisions-Werkzeughalter für Werkzeugmaschinen und Bearbeitungszentren, die mit extremer Flexibilität und Starre Ausbohr-, Fräs-, Bohr-, und Gewindebohrarbeiten ermöglichen. Die zylindrisch-konische Verbindung in elf Größen garantiert die Austauschbarkeit aller Elemente des Systems, das Basisanschlüsse HSK, DIN, BT und CAT und Polygon-shank Verlängerungen, Reduktionen und Adapter für Werkzeughalter mit einschließt. Das vielseitige Ausbohrprogramm zur Bearbeitung von Durchmessern von 2,5 bis 2700 mm, vervollständigt die Linie MHD' mit den zweiseitigen Grobbearbeitungsköpfen und den zentesimalen und mikrometrischen Feinbearbeitungsköpfen Testarossa mit einer Einstellfeinheit von 2µm.

**E** Portaherramientas modulares de alta precisión para máquinas herramientas y centros de mecanizado que permiten efectuar con extrema flexibilidad y rigidez, operaciones de mandrinado, fresado, taladrado y roscado. El acoplamiento cilíndrico-cónico disponible en once tamaños, garantiza la intercambiabilidad de todos los elementos del sistema, que incluye uniones base HSK, DIN, BT y CAT y Polygon-shank, prolongadores, reducciones y adaptadores portaherramientas. El amplio programa de mandrinado para la elaboración de diámetros de 2,5 a 2700 mm, completa la línea MHD' con los cabezales de desbaste de doble cuchilla y los cabezales de acabado centesimales y micrométricos Testarossa con sensibilidad de ajuste de 2µm.

**F** Ce sont des porte-outils modulaires de haute précision pour les machines-outils et les centres d'usinage, qui permettent d'effectuer, grâce à leur grande flexibilité et rigidité, des opérations alésage, fraisage, forage et taraudage. L'accouplement cylindrique-conique, offrant onze grandeurs, garantit l'interchangeabilité de tous les éléments du système, qui comprend des fixations de base HSK, DIN, BT, CAT et jambe conique par polygone (Polygon-shank), des rallonges, des réductions et des adaptateurs porte-outils. Le riche programme d'alésage pour l'usinage des diamètres allant de 2,5 à 2700 mm complète la ligne MHD' avec les têtes de dégrossissage à double tranchant et les têtes de finition centésimales et micrométriques Testarossa, à la sensibilité de réglage de 2 µm.

**I** Portautensili modulari di alta precisione per macchine utensili e centri di lavoro che consentono di eseguire con estrema flessibilità e rigidità, operazioni di alesatura, fresatura, foratura e maschiatura. L'accoppiamento cilindrico-conico disponibile in undici grandezze, garantisce l'intercambiabilità di tutti gli elementi del sistema, che include attacchi base HSK, DIN, BT, CAT e Polygon-shank, prolunghe, riduzioni e adattatori portautensili. Il ricco programma di alesatura per la lavorazione di diametri da 2,5 a 2700 mm, completa la linea MHD' con le testine di sgrossatura bitaglianti e le testine di finitura centesimali e micrometriche Testarossa con sensibilità di regolazione di 2µm.



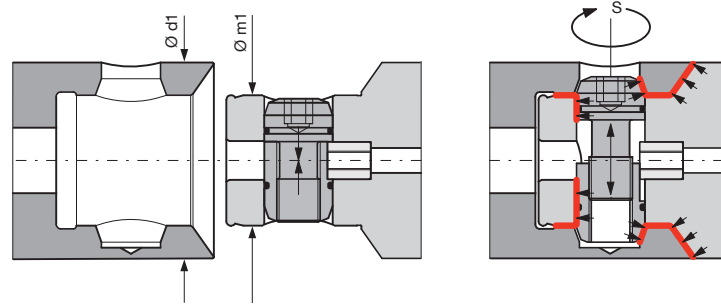
**GB The MHD' coupling** is the heart of the tool system as it ensures utmost rigidity and concentricity during milling and boring operations. This is achieved by the (patented) cylindrical-conical fit and by a radial expanding bolt for clamping and driving.


**D Die MHD' Kupplung** ist das Kernstück des MODULHARD'ANDREA, da sie maximale Starrheit und Konzentrität beim Fräsen und Bohren sichert. Das wird durch die (patentierte) zylindrisch-konische Passfläche und den radialen Spreizbolzen für Axialspannung und Mitnahme erreicht.

**E El acoplamiento MHD'** es el punto de fuerza del MODULHARD'ANDREA, porque permite fresar y mandrinar con la máxima rigidez y concentricidad, gracias al acoplamiento (patentado) cilíndrico-cónico y al perno radial expansible para el bloqueo axial y el arrastre.

**F L'accouplement MHD'** est l'atout du système d'outils parce qu'il assure une extrême rigidité et concentricité dans les opérations de fraisage et d'alésage grâce au siège cylindrique-conique (breveté) et à une tige radiale expansible pour le blocage et l'entraînement.

**I L'attacco MHD'** è il punto di forza del Modulhard'andrea perché consente di fresare ed alesare con massima rigidità e concentricità grazie all'accoppiamento (brevettato) cilindrico-conico e al perno radiale espandibile per il bloccaggio assiale e il trascinamento.



MHD'	Ø d1	Ø m1	S 	Nm
MHD' 14	14	10	2,5	2 - 2,5
MHD' 16	16			
MHD' 20	20	13	3	4 - 4,5
MHD' 25	25	16	3	6,5 - 7,5
MHD' 32	32	20	4	7 - 8
MHD' 40	40	25	5	16 - 18
MHD' 50	50	32	6	30 - 35
MHD' 63	63	42	8	70 - 80
MHD' 80	80			
MHD' 110	110	76	14	200 - 220
MHD' 140	140			

- GENERAL INFORMATIONS
- ALLGEMEINES
- INFORMACIONES GENERALES
- GENERALITES
- INFORMAZIONI GENERALI

**GB Assembly:** Secure the arbor to a rigid support. Fit the required component (adaptor, extension, boring head etc.) to the arbor ensuring that the radial expanding pin does not project from the cylindrical part. Clamp the component by turning the radial pin clockwise with the exagonal wrench provided or with a torque wrench. **Disassembly:** secure the arbor to a rigid support. Unlock the radial pin by turning it counterclockwise.

**D Montage:** Die Grundaufnahme in einer Halterung befestigen. Gewünschtes Komponente (Reduzierung, Verlängerun, Ausdrehkopf usw.) einsetzen. Darauf achten, dass der radiale Spreizbolzen nicht aus dem zylindrischen Teil heraus ragt. Element durch Rechtsdrehen des Spreizbolzens mit dem mitgelieferten Sechskantschlüssel oder einem Drehmomentschlüssel festklemmen. **Demontage:** Grundaufnahme in einer Halterung befestigen. Spreizbolzen durch Linksdrehen lösen.

**E Montaje:** Asegurar el acoplamiento base en un soporte. Montar el elemento deseado (reducción, prolongación, cabezal para mandrinar etc.) asegurándose que el perno radial no sobresalga del núcleo cilíndrico. Fijar girando en sentido horario el perno radial con la llave exagonal en dotación o con una llave torsiométrica. **Desmontaje:** Asegurar el acoplamiento base en un soporte. Desbloquear, girando a fondo en sentido antihorario, el perno radial.

**F Montage:** Fixer le mandrin dans un support. Monter l'élément désiré (réduction, rallonge, tête à aléser etc...) et s'assurer que la tige radiale expansible ne saillit pas de la partie cylindrique. Bloquer l'élément en tournant la tige radiale dans le sens des aiguilles d'une montre au moyen de la clé hexagonale fournie ou d'une clé dynamométrique. **Demontage:** Fixer le mandrin dans un support. Débloquer l'élément en tournant la tige radiale en sens inverse des aiguilles d'une montre.

**I Montaggio:** Assicurare l'attacco base in un supporto. Montare l'elemento desiderato (riduzione, prolunga, testina per alesare ecc.) assicurandosi che il perno radiale non sporga dal mozzo cilindrico. Bloccare ruotando in senso orario il perno radiale con la chiave esagonale in dotazione o con una chiave torsiometrica. **Smontaggio:** Assicurare l'attacco base in un supporto. Sbloccare, ruotando a fondo in senso antiorario, il perno radiale.



- ARBORS EXTENSIONS REDUCTIONS
- GRUNDAUFNAHMEN VERLÄNGERUNGEN REDUZIERUNGEN
- ACOPLAMIENTOS BASE PROLONGACIONES REDUCCIONES
- MANDRINS RALLONGES RÉDUCTIONS
- ATTACCHI BASE PROLUNGHE RIDUZIONI

**GB ARBORS.** Arbors are manufactured in accordance with DIN 69871 A-B, MAS 403 BT, DIN 2080, ANSI-CAT, DIN 69893-A, ISO 26623-1 and are made of carburized steel, hardened and ground to AT3 tolerance. Arbor sizes MHD' 80, 110 and 140 are recommended for heavy milling and for bores deeper than 250 mm and exceeding 125 mm diameter. Special arbors are available on request.

**EXTENSIONS.** Extensions of various lengths are available for each MHD' size, allowing greater flexibility in machining depth.

**REDUCTIONS.** MHD' components of a smaller size can be used by means of adaptor sleeves which allow greater interchangeability and ensure tool rigidity.

**D GRUNDAUFNAHMEN.** Die Grundaufnahmen entsprechen den Normen DIN 69871 A-B, MAS 403 BT, DIN 2080, ANSI-CAT, DIN 69893-A, ISO 26623-1. Sie werden aus Einsatzstahl gefertigt, gehärtet und auf Toleranz AT3 geschliffen. Für schwere Fräsarbeiten und Bohrungen mit Tiefen über 250 mm und Durchmessern über 125 mm ist der Einsatz von Grundaufnahmen Größe MHD' 80, 110 und 140 zweckmäßig. Grundaufnahmen in Sonderausführung sind auf Anfrage lieferbar.

**VERLÄNGERUNGEN.** Für jede MHD' Größe sind Verlängerungen verschiedener Länge vorhanden, die eine größere Anpassungsfähigkeit an die Bearbeitungstiefe ermöglichen.

**REDUZIERUNGEN.** Die Reduzierungen ermöglichen die Verwendung der Komponenten kleinerer MHD' Größen. Damit ist eine umfassende Austauschbarkeit und größere Steifigkeit gegeben.

**E ACOPLAMIENTOS BASE.** Los acoplamiento son realizados según las normas DIN 69871 A-B, MAS 403 BT, DIN 2080, ANSI-CAT, DIN 69893-A, ISO 26623-1 y son construidos en acero cementado, templado y rectificado según tabla AT3. El empleo de acoplamiento con tamaños MHD' 80, 110 y 140 son aconsejables para operaciones de fuerte fresado y para los mandrinados profundos, por encima de los 250 mm con diámetros superiores a 125 mm. A petición, se pueden construir acoplamiento especiales.

**PROLONGACIONES.** Para cada tamaño de MHD' existen prolongaciones de diferentes longitudes que permiten optimizar las profundidades de mecanización deseadas.

**REDUCCIONES.** Las reducciones permiten utilizar componentes de un tamaño MHD' más pequeño y, por lo tanto, tener mayor intercambiabilidad y estabilidad de la herramienta.

**F MANDRINS.** Les mandrins, conformes aux normes DIN 69871 A-B, MAS 403 BT, DIN 2080, ANSI-CAT, DIN 69893-A, ISO 26623-1 sont fabriqués en acier de cémentation trempé et rectifié à la tolérance AT3. Les tailles MHD' 80, 110 et 140 sont conseillée pour des travaux de fraisage lourds et d'alésage de profondeur supérieure à 250 mm et de diamètre supérieur à 125 mm. Des mandrins spéciaux sont livrables sur demande.

**RALLONGES.** Pour chaque taille MHD' des rallonges de différentes longueurs sont prévues. Elles permettent une plus grande souplesse d'adaptation à la profondeur d'usinage.

**RÉDUCTIONS.** Les réductions sont utilisées pour l'emploi des éléments d'une taille MHD' plus petite et améliorent ainsi l'interchangeabilité et la rigidité de l'outil.

**I ATTACCHI BASE.** Gli attacchi sono realizzati secondo le norme DIN 69871 A-B, MAS 403 BT, DIN 2080, ANSI-CAT, DIN 69893-A, ISO 26623-1 e sono costruiti in acciaio cementato, temperato e rettificato secondo la tabella AT3. L'impiego di attacchi con grandezze MHD' 80, 110 e 140 sono consigliati per operazioni di fresatura pesante e per alesature profonde oltre i 250 mm con diametri superiori a 125 mm. A richiesta si possono costruire attacchi speciali.

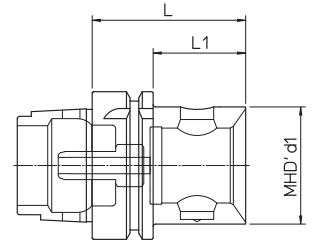
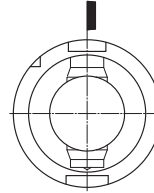
**PROLUNGHE.** Per ogni grandezza di MHD' esistono prolunghe di differenti lunghezze che consentono di ottimizzare le profondità di lavorazione desiderate.

**RIDUZIONI.** Le riduzioni permettono di utilizzare componenti di una grandezza MHD' più piccola e quindi avere maggiore intercambiabilità e stabilità dell'utensile.



- ARBORS
- GRUNDAUFNAHMEN
- ACOPLAMIENTOS BASE
- MANDRINS
- ATTACCHI BASE

## DIN 69893 HSK-A

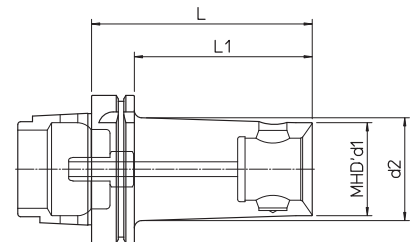
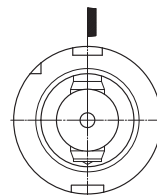


- Supplied with coolant tube
- Lieferung inklusive Kühlmittelrohr
- Completo con racor para el refrigerante
- Pourvu de raccord pour liquide d'arrosage
- Completo di raccordo per il refrigerante

- \* Supplied without hole
- \* Ohne lock aus gestattet
- \* Hecho sin agujero
- \* Fourni sans perce
- \* Fornito senza foro

HSK-A	REF.	CODE	MHD' d <sub>1</sub>	L	L <sub>1</sub>	kg
40	HSK-A40 MHD'32.48	416321504020 *	32	48	28	0.4
50	HSK-A50 MHD'50.66	416501505020	50	66	–	0.6
63	HSK-A63 MHD'40.60	416401506320	40	60	34	0.7
	HSK-A63 MHD'50.66	416501506320	50	66	40	0.9
	HSK-A63 MHD'63.75	416631506320	63	75	–	1.1
80	HSK-A80 MHD'50.70	416501508020	50	70	44	1.5
	HSK-A80 MHD'63.80	416631508020	63	80	54	1.8
	HSK-A80 MHD'80.86	416801508020	80	86	–	2.1
100	HSK-A100 MHD'50.72	416501510020	50	72	43	2.4
	HSK-A100 MHD'63.82	416631510020	63	82	53	2.7
	HSK-A100 MHD'80.88	416801510020	80	88	59	3

## DIN 69893 HSK-A

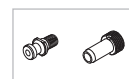


- Supplied with coolant tube
- Lieferung inklusive Kühlmittelrohr
- Completo con racor para el refrigerante
- Pourvu de raccord pour liquide d'arrosage
- Completo di raccordo per il refrigerante

HSK-A	REF.	CODE	MHD' d <sub>1</sub>	d <sub>2</sub>	L	L <sub>1</sub>	kg
63	HSK-A63 MHD'40.120	416401506328	40	46	120	94	1.4
	HSK-A63 MHD'50.120	416501506328	50	–			1.7
100	HSK-A100 MHD'50.120	416501510028	50	60	150	121	3.2
	HSK-A100 MHD'63.150	416631510028	63	70			4.5
	HSK-A100 MHD'80.180	416801510028	80	–			180

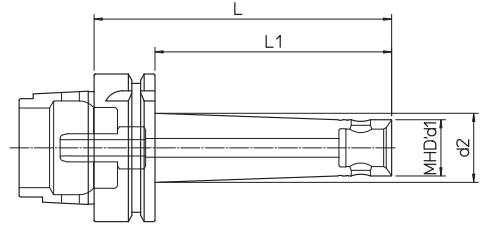
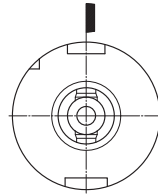
240

248



- ARBORS
- GRUNDAUFNAHMEN
- ACOPLAMIENTOS BASE
- MANDRINS
- ATTACCHI BASE

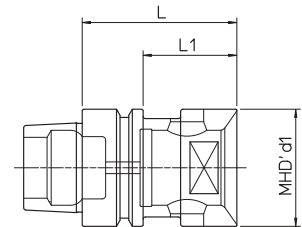
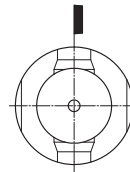
DIN 69893  
HSK-A



- Supplied with coolant tube
- Lieferung inklusive Kühlmittelrohr
- Completo con racor para el refrigerante
- Pourvu de raccord pour liquide d'arrosage
- Completo di raccordo per il refrigerante

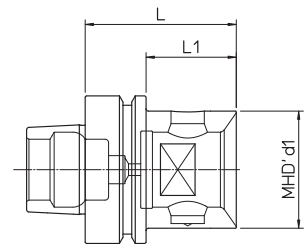
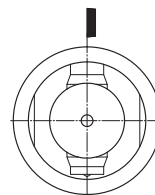
HSK-A	REF.	CODE	MHD' d <sub>1</sub>	d <sub>2</sub>	L	L <sub>1</sub>	kg
63	HSK-A63 MHD'16.63	416160656320	16	17	63	37	0.7
	HSK-A63 MHD'16.100	416161056320		19.5	100	74	0.8
	HSK-A63 MHD'20.63	416200656320	20	-	63	37	0.6
	HSK-A63 MHD'20.90	416200956320		22.5	90	64	0.8
	HSK-A63 MHD'20.125	416201256320	25	125	99	0.9	
	HSK-A63 MHD'25.63	416250656320	25	-	63	37	0.7
	HSK-A63 MHD'25.90	416250956320		27	90	64	0.9
	HSK-A63 MHD'25.125	416251256320		29.5	125	99	1
	HSK-A63 MHD'32.90	416320956320		33.5	90	64	1
	HSK-A63 MHD'32.125	416321256320	36	125	99	1.2	

DIN 69893  
HSK-E



HSK-E	REF.	CODE	MHD' d <sub>1</sub>	L	L <sub>1</sub>	kg
40	HSK-E40 MHD'32.42	416321504025	32	42	22	0.5
50	HSK-E50 MHD'50.66	416501505025	50	66	-	0.6
63	HSK-E63 MHD'50.66	416501506325			40	0.9

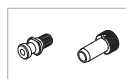
DIN 69893  
HSK-F



HSK-F	REF.	CODE	MHD' d <sub>1</sub>	L	L <sub>1</sub>	kg
63	HSK-F63 MHD'50.65	416501506326	50	65	39	0.8

248

240



- ARBORS
- GRUNDAUFNAHMEN
- ACOPLAMIENTOS BASE
- MANDRINS
- ATTACCHI BASE

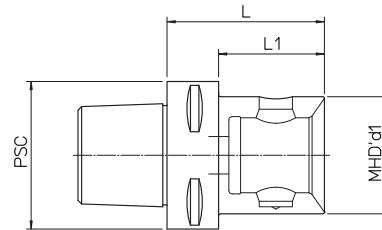
**PSC-MHD'**  
**ISO 26623-1**


fig.1

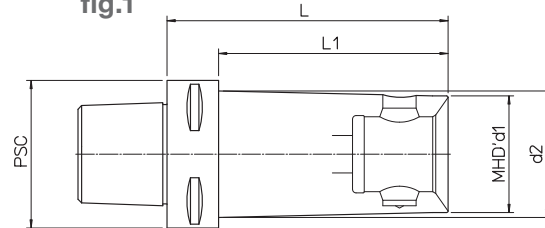
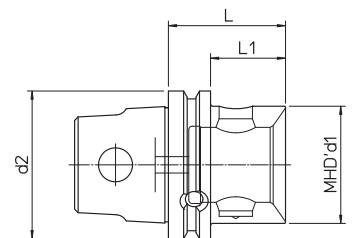


fig.2

PSC	REF.	CODE	MHD' d1	d2	L	L1	Kg.	fig.
40	PSC 40 - MHD' 32.42	416322604004	32	-	42	22	0.3	1
	PSC 40 - MHD' 40.45	416402604004	40		45	-	0.4	
50	PSC 50 - MHD' 50.55	416502605005	50	-	55	-	0.8	
63	PSC 63 - MHD' 40.50	416402606305	40	-	50	28	0.9	
	PSC 63 - MHD' 40.120	416402606312	40	44	120	98	1.5	2
	PSC 63 - MHD' 50.55	416502606305	50	-	55	33	0.8	1
	PSC 63 - MHD' 50.67	416502606306	50	-	67	45	1.1	1
	PSC 63 - MHD' 50.120	416502606312	50	54	120	98	1.9	2
	PSC 63 - MHD' 63.77	416632606307	63	-	77	-	1.8	1
80	PSC 80 - MHD' 50.60	416502608006	50	-	60	30	2	1
	PSC 80 - MHD' 50.120	416502608012	50	54	120	90	2.8	2
	PSC 80 - MHD' 63.70	416632608007	63	-	70	40	2.3	1
	PSC 80 - MHD' 63.150	416632608015	63	67	150	120	4	2
	PSC 80 - MHD' 80.75	416802608007	80	-	75	-	2.6	1
	PSC 80 - MHD' 80.120	416802608012	80	-	120	-	4.3	
100	PSC 100 - MHD' 80.80	416802610008	80	-	80	44	3.5	1
	PSC 100 - MHD' 110.120	416912610012	110	-	120	84	5	

**ISO 26622-1**  
**KM**


KM	REF.	CODE	MHD' d1	d2	L	L1	kg
63	RD KM - MHD' 50.50	657095005063	50	63	50	32	0.8
	RD KM - MHD' 63.70	657096305063	63		70	-	1.2



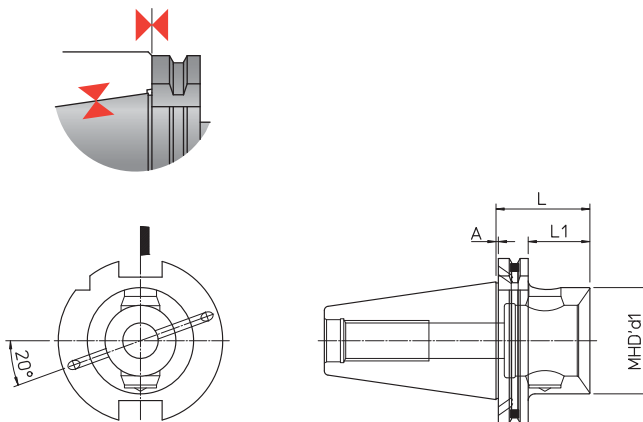
# D'ANDREA

## MODULHARD'ANDREA

### FACE CONTACT

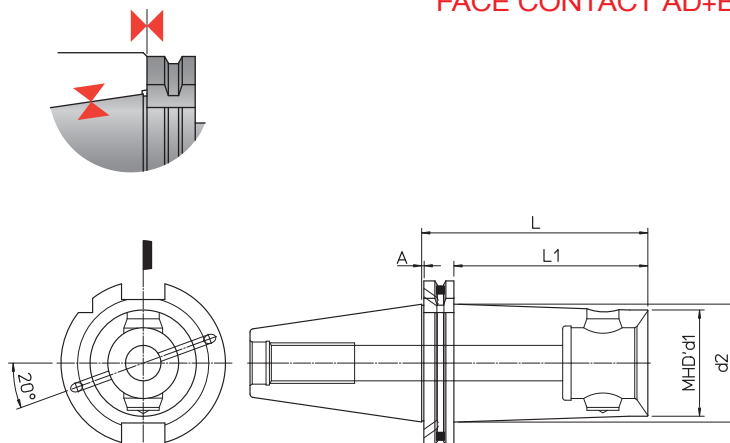
- ARBORS
- GRUNDAUFNAHMEN
- ACOPLAMIENTOS BASE
- MANDRINS
- ATTACCHI BASE

DIN 69871 FC  
FACE CONTACT AD+B

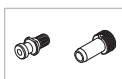


DIN	REF.	CODE	MHD' d <sub>1</sub>	A	L	L <sub>1</sub>	Kg.
40	DIN69871-AD+B40 FC MHD'50.48	416500104021F	50	1	48	29	0.9
	DIN69871-AD+B40 FC MHD'63.80	416630104021F	63		80	-	1.5
50	DIN69871-AD+B50 FC MHD'50.48	416500105021F	50	1.5	48	29	2.5
	DIN69871-AD+B50 FC MHD'63.56	416630105021F	63		56	37	2.8
	DIN69871-AD+B50 FC MHD'80.62	416800105021F	80		62	43	3.4

DIN 69871 FC  
FACE CONTACT AD+B

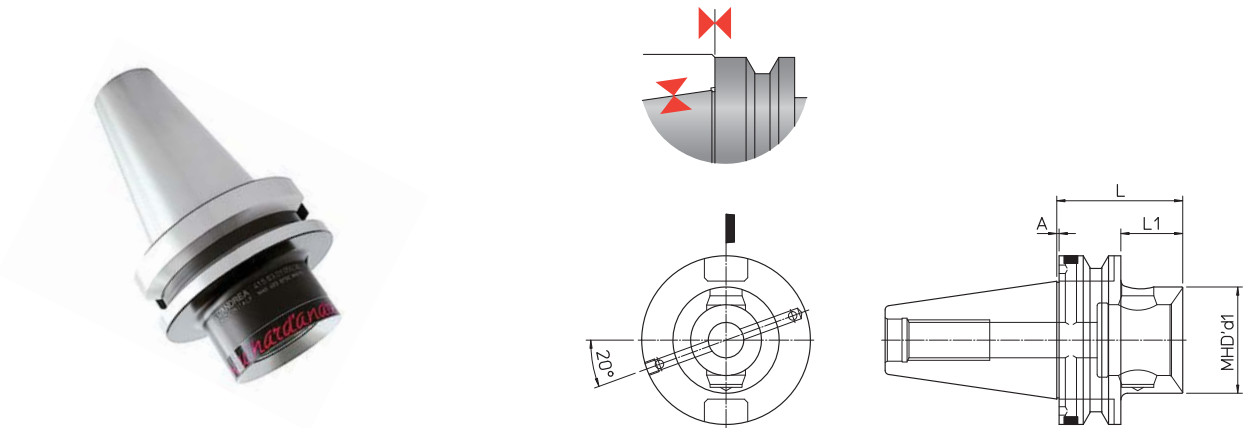


DIN	REF.	CODE	MHD' d <sub>1</sub>	d <sub>2</sub>	A	L	L <sub>1</sub>	Kg.
40	DIN69871-AD+B40 FC MHD'50.120	416500104028F	50	-	1	120	101	1.7
	DIN69871-AD+B50 FC MHD'50.120	416500105028F		59				3.5
50	DIN69871-AD+B50 FC MHD'50.200	416500105027F	63	68	1.5	200	181	6.1
	DIN69871-AD+B50 FC MHD'63.150	416630105028F		75.5		150	131	5.2
	DIN69871-AD+B50 FC MHD'63.250	416630105027F	80	250		231	7.1	
	DIN69871-AD+B50 FC MHD'80.180	416800105028F	80	-		180	161	6.9
	DIN69871-AD+B50 FC MHD'80.300	416800105027F				300	281	9.2
	DIN69871-AD+B50 FC MHD'110.150	416910105021F	110	-		150	-	8
	DIN69871-AD+B50 FC MHD'110.250	416910105028F				250	-	15



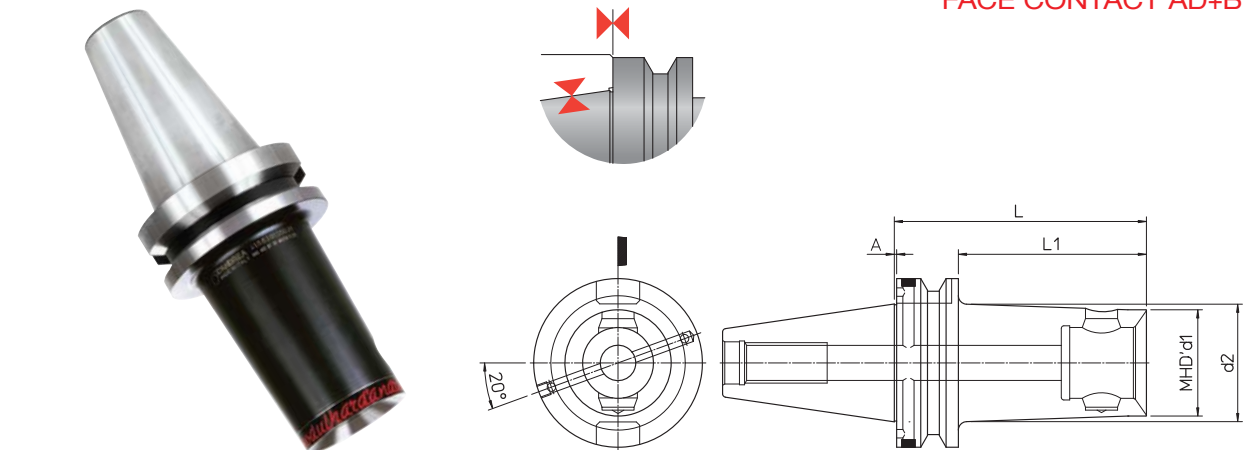
- ARBORS
- GRUNDAUFNAHMEN
- ACOPLAMIENTOS BASE
- MANDRINS
- ATTACCHI BASE

## MAS 403 BT FC FACE CONTACT AD+B

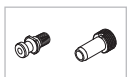


DIN	REF.	CODE	MHD' d <sub>1</sub>	A	L	L <sub>1</sub>	Kg.
40	MAS403 BT40 FC AD+B MHD'50.48	416500104031F	50	1	48	21	0.9
	MAS403 BT40 FC AD+B MHD'63.66	416630104031F	63			-	1.2
50	MAS403 BT50 FC AD+B MHD'50.66	416500105031F	50	1.5	66	28	3.2
	MAS403 BT50 FC AD+B MHD'63.75	416630105031F	63			3.7	
	MAS403 BT50 FC AD+B MHD'80.75	416800105031F	80			4	

## MAS 403 BT FC FACE CONTACT AD+B



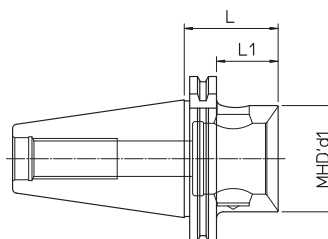
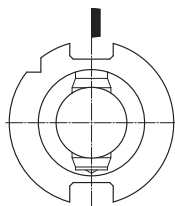
DIN	REF.	CODE	MHD' d <sub>1</sub>	d <sub>2</sub>	A	L	L <sub>1</sub>	Kg.
40	MAS403 BT40 FC AD+B MHD'50.120	416500104038F	50	-	1	120	93	1.9
50	MAS403 BT50 FC AD+B MHD'50.120	416500105038F		57.5			1.5	200
	MAS403 BT50 FC AD+B MHD'50.200	416500105037F	66	162	4.5			
	MAS403 BT50 FC AD+B MHD'63.150	416630105038F	73.5	150	112	5.8		
	MAS403 BT50 FC AD+B MHD'63.250	416630105037F	84	250	212	6.1		
	MAS403 BT50 FC AD+B MHD'80.180	416800105038F	80	-	1.5	180	142	7.5
	MAS403 BT50 FC AD+B MHD'80.300	416800105037F				300	262	9.2
	MAS403 BT50 FC AD+B MHD'110.150	416910105031F	110	-	1.5	150	-	8.1
	MAS403 BT50 FC AD+B MHD'110.250	416910105038F				250	-	15.3



- ARBORS
- GRUNDAUFNAHMEN
- ACOPLAMIENTOS BASE
- MANDRINS
- ATTACCHI BASE

DIN 69871

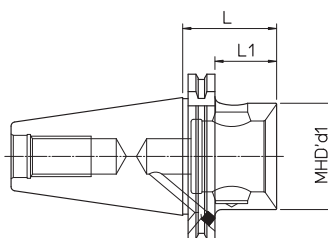
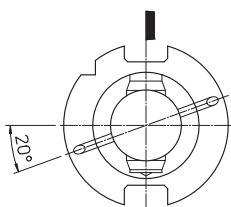
AD



DIN	REF.	CODE	MHD' d1	L	L1	kg
30	DIN69871-A30 MHD'32.30	416320103020	32	30	11	0.4
	DIN69871-A30 MHD'40.45.5	416400103020	40	45.5	26.5	0.5
	DIN69871-A30 MHD'50.60	416500103020	50	60	-	0.6
40	DIN69871-A40 MHD'40.45	416400104020	40	45	26	0.5
	DIN69871-A40 MHD'50.48	416500104020	50	48	29	0.9
	DIN69871-A40 MHD'50.56	416500104070		56	37	1.1
	DIN69871-A40 MHD'63.80	416630104020	63	80	-	1.5
45	DIN69871-A45 MHD'50.48	416500104520	50	48	29	1.7
	DIN69871-A45 MHD'63.60	416630104520	63	60	41	1.9
	DIN69871-A45 MHD'80.66	416800104520	80	66	-	2.2
50	DIN69871-A50 MHD'50.48	416500105020	50	48	29	2.5
	DIN69871-A50 MHD'63.48	416630105029				2.6
	DIN69871-A50 MHD'63.56	416630105020	63	56	37	2.8
	DIN69871-A50 MHD'80.48	416800105029	80	48	29	3
	DIN69871-A50 MHD'80.62	416800105020		62	43	3.4
	DIN69871-A50 MHD'110.150	416910105020		110	150	-
	DIN69871-A50 MHD'140.160	416940105020	140	160	-	10
60	DIN69871-A60 MHD'50.50	416500106020	50	50	31	8.3
	DIN69871-A60 MHD'63.60	416630106020	63	60	41	9.3
	DIN69871-A60 MHD'80.65	416800106020	80	65	46	10.3
	DIN69871-A60 MHD'110.100	416910106020	110	100	81	10.5
	DIN69871-A60 MHD'110.200	416910106028		200	181	18
	DIN69871-A60 MHD'140.100	416940106020	140	100	81	12.8
	DIN69871-A60 MHD'140.250	416940106028		250	231	30

DIN 69871

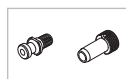
B



DIN	REF.	CODE	MHD' d1	L	L1	kg
40	DIN69871-B40 MHD'50.48	416500104021	50	48	29	0.9
	DIN69871-B40 MHD'63.80	416630104021	63	80	-	1.5
45	DIN69871-B45 MHD'50.48	416500104521	50	48	29	1.7
	DIN69871-B45 MHD'63.60	416630104521	63	60	41	1.9
	DIN69871-B45 MHD'80.66	416800104521	80	66	-	2.2
50	DIN69871-B50 MHD'50.48	416500105021	50	48	29	2.7
	DIN69871-B50 MHD'63.56	416630105021	63	56	37	2.8
	DIN69871-B50 MHD'80.62	416800105021	80	62	43	3.4

249

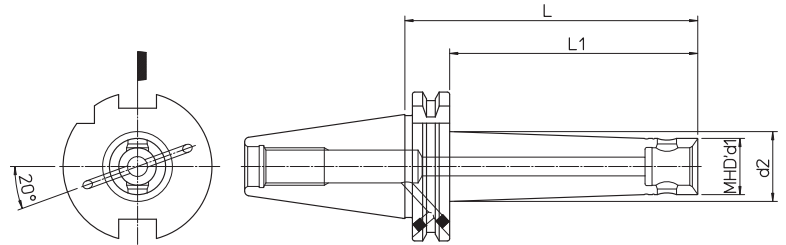
240



- ARBORS
- GRUNDAUFNAHMEN
- ACOPLAMIENTOS BASE
- MANDRINS
- ATTACCHI BASE

## DIN 69871

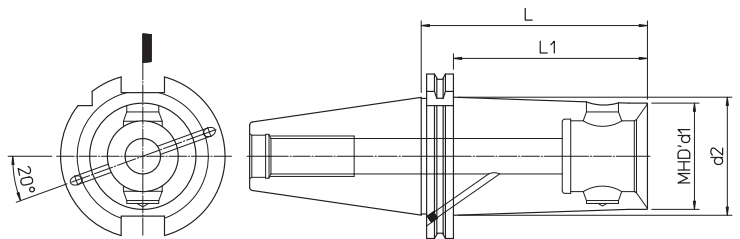
### AD+B



DIN	REF.	CODE	MHD' d1	d2	L	L1	kg
40	DIN69871-AD+B40 MHD'16.40	416160414021	16	-	40	21	0.7
	DIN69871-AD+B40 MHD'16.63	416160614021		17.5	63	44	0.8
	DIN69871-AD+B40 MHD'16.100	416161014021		20	100	81	0.9
	DIN69871-AD+B40 MHD'20.50	416200514021	20	-	50	31	0.8
	DIN69871-AD+B40 MHD'20.80	416200814021		22.5	80	61	0.9
	DIN69871-AD+B40 MHD'20.125	416201214021		25.5	125	106	1
	DIN69871-AD+B40 MHD'25.50	416250514021	25	-	50	31	0.9
	DIN69871-AD+B40 MHD'25.80	416250814021		27	80	61	1
	DIN69871-AD+B40 MHD'25.125	416251214021		30	125	106	1.1
	DIN69871-AD+B40 MHD'32.50	416320514021	32	-	50	31	1
	DIN69871-AD+B40 MHD'32.80	416320814021		33.5	80	61	1.1
	DIN69871-AD+B40 MHD'32.125	416321214021		36.5	125	106	1.2

## DIN 69871

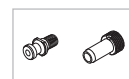
### AD+B



DIN	REF.	CODE	MHD' d1	d2	L	L1	kg
40	DIN69871-AD+B40 MHD'40.120	416400104028	40	44.5	120	101	1.4
	DIN69871-AD+B40 MHD'50.120	416500104028	50	-			1.7
50	DIN69871-AD+B50 MHD'50.120	416500105028	50	60	150	131	3.5
	DIN69871-AD+B50 MHD'63.150	416630105028	63	70			5
	DIN69871-AD+B50 MHD'80.180	416800105028	80	-			180

240

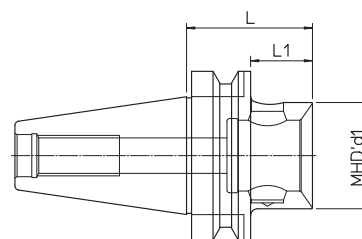
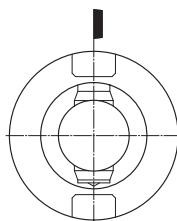
249





- ARBORS
- GRUNDAUFNAHMEN
- ACOPLAMIENTOS BASE
- MANDRINS
- ATTACCHI BASE

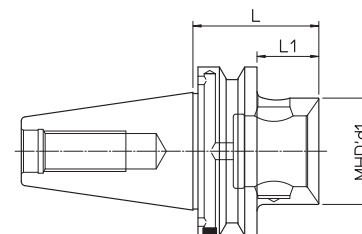
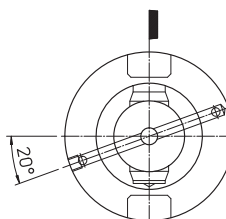
### MAS 403 BT



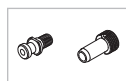
BT	REF.	CODE	MHD' d1	L	L1	kg
30	MAS403 BT30 MHD'32.32	416320103030	32	32	10.5	0.5
	MAS403 BT30 MHD'40.35.5	416400103030	40	35.5	14	0.6
	MAS403 BT30 MHD'50.60	416500103030	50	60	–	0.7
35	MAS403 BT35 MHD'50.60	416500103530			36	0.8
40	MAS403 BT40 MHD'40.45	416400104030	40	45	18	0.6
	MAS403 BT40 MHD'50.38.5	416500104039	50	38.5	11.5	0.8
	MAS403 BT40 MHD'50.48	416500104030		48	21	0.9
	MAS403 BT40 MHD'50.56	416500104080	56	29	1.1	
	MAS403 BT40 MHD'63.66	416630104030	63	66	–	1.2
45	MAS403 BT45 MHD'50.62	416500104530	50	62	29	1.7
	MAS403 BT45 MHD'63.70	416630104530	63	70	37	2.3
	MAS403 BT45 MHD'80.70	416800104530	80			2.7
50	MAS403 BT50 MHD'50.66	416500105030	50	66	28	3.3
	MAS403 BT50 MHD'63.50	416630105039	63	50	12	3.4
	MAS403 BT50 MHD'63.75	416630105030		75	37	3.7
	MAS403 BT50 MHD'80.50	416800105039	80	50	12	3.8
	MAS403 BT50 MHD'80.75	416800105030		75	37	4
	MAS403 BT50 MHD'110.140	416910105030	110	140	–	6.8
	MAS403 BT50 MHD'140.150	416940105030	140	150	–	9.2
60	MAS403 BT60 MHD'110.110	416910106030	110	110	63	11.5
	MAS403 BT60 MHD'110.200	416910106038		200	152	18.1
	MAS403 BT60 MHD'140.100	416940106030	140	100	52	12.9
	MAS403 BT60 MHD'140.250	416940106038		250	202	30.1

### MAS 403 BT

B



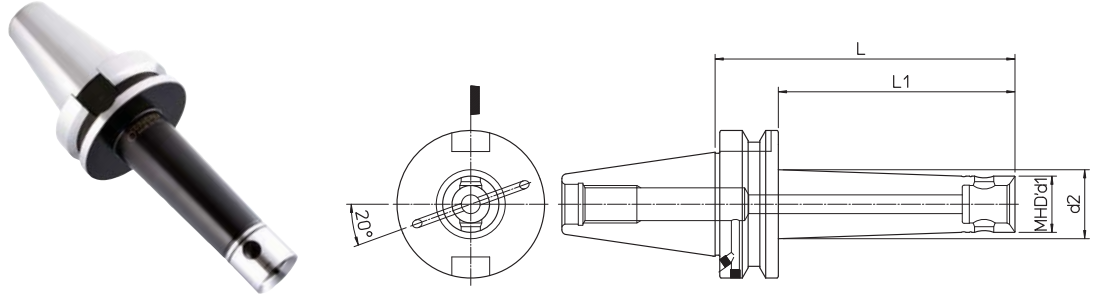
BT	REF.	CODE	MHD' d1	L	L1	kg
40	MAS403 BT40B MHD'50.48	416500104031	50	48	21	0.9
	MAS403 BT40B MHD'63.66	416630104031	63	66	–	1.2
50	MAS403 BT50B MHD'50.66	416500105031	50	66	28	3.5
	MAS403 BT50B MHD'63.75	416630105031	63	75	37	3.7
	MAS403 BT50B MHD'80.75	416800105031	80			4



- ARBORS
- GRUNDAUFNAHMEN
- ACOPLAMIENTOS BASE
- MANDRINS
- ATTACCHI BASE

## MAS 403 BT

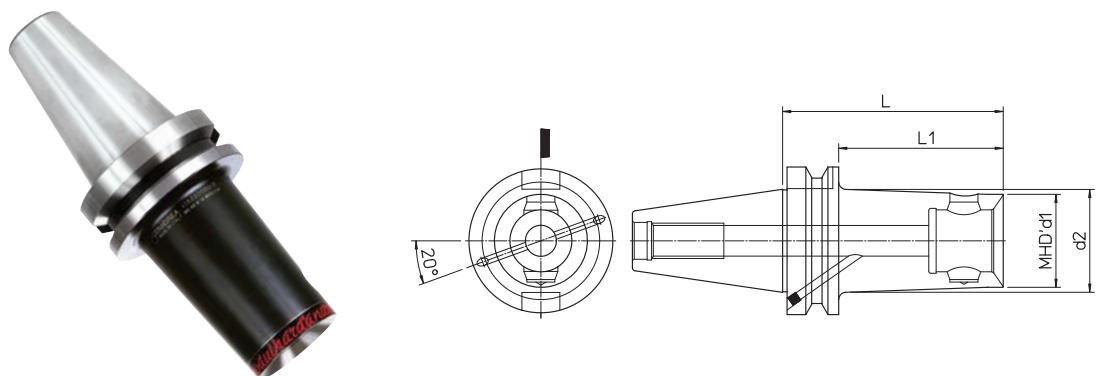
AD+B



BT	REF.	CODE	MHD' d1	d2	L	L1	kg
40	MAS403 BT40-AD+B MHD'16.45	416160414031	16	-	45	18	0.8
	MAS403 BT40-AD+B MHD'16.63	416160614031		17	63	36	0.9
	MAS403 BT40-AD+B MHD'16.100	416161014031		19.5	100	73	1
	MAS403 BT40-AD+B MHD'20.50	416200514031	20	-	50	23	0.9
	MAS403 BT40-AD+B MHD'20.80	416200814031		22	80	53	1
	MAS403 BT40-AD+B MHD'20.125	416201214031		25	125	98	1.1
	MAS403 BT40-AD+B MHD'25.50	416250514031	25	-	50	23	1
	MAS403 BT40-AD+B MHD'25.80	416250814031		26.5	80	53	1.1
	MAS403 BT40-AD+B MHD'25.125	416251214031		29.5	125	98	1.2
	MAS403 BT40-AD+B MHD'32.50	416320514031	32	-	50	23	1.1
	MAS403 BT40-AD+B MHD'32.80	416320814031		33	80	53	1.2
	MAS403 BT40-AD+B MHD'32.125	416321214031		36	125	98	1.4

## MAS 403 BT

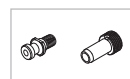
AD+B



BT	REF.	CODE	MHD' d1	d2	L	L1	kg
40	MAS403 BT40-AD+B MHD'40.120	416400104038	40	44.5	120	93	0.9
	MAS403 BT40-AD+B MHD'50.120	416500104038	50	-			1.9
50	MAS403 BT50-AD+B MHD'50.120	416500105038	50	60	150	112	4.2
	MAS403 BT50-AD+B MHD'63.150	416630105038	63	70			5.8
	MAS403 BT50-AD+B MHD'80.180	416800105038	80	-			180

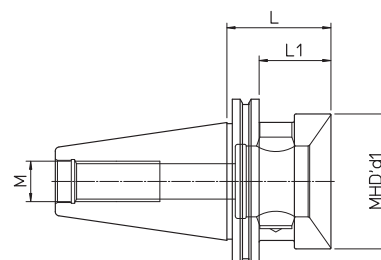
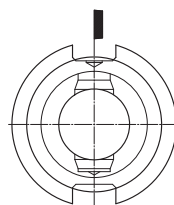
240

249



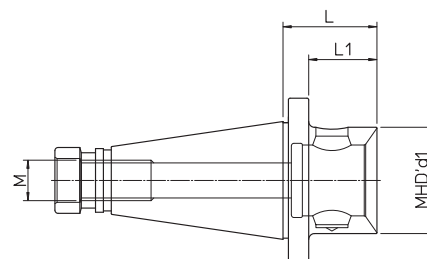
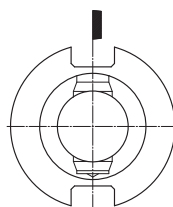
- ARBORS
- GRUNDAUFNAHMEN
- ACOPLAMIENTOS BASE
- MANDRINS
- ATTACCHI BASE

### ANSI/CAT



ANSI/CAT	REF.	CODE	MHD' d <sub>1</sub>	L	L <sub>1</sub>	M	kg
40	ANSI/CAT40 MHD'50.66	416500104040	50	66	47	M16	1.1
	ANSI/CAT40 MHD'63.100	416630104040	63	100	-		1.9
45	ANSI/CAT45 MHD'50.48	416500104540	50	48	29	M20	1.7
	ANSI/CAT45 MHD'63.75	416630104540	63	75	56		2.1
	ANSI/CAT45 MHD'80.80	416800104540	80	80	-		2.7
50	ANSI/CAT50 MHD'50.48	416500105040	50	48	29	M24	2.4
	ANSI/CAT50 MHD'63.56	416630105040	63	56	37		2.9
	ANSI/CAT50 MHD'80.62	416800105040	80	62	43		3.2

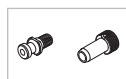
### DIN 2080-A 'OTT'



ISO	REF.	CODE	MHD' d <sub>1</sub>	L	L <sub>1</sub>	M	kg
30	DIN2080-A30 MHD'50.58	416500103000	50	58	-	M12	0.6
40	DIN2080-A40 MHD'50.48	416500104000	50	48	36.5	M16	0.9
	DIN2080-A40 MHD'63.60	416630104000	63	60	-		1.2
45	DIN2080-A45 MHD'50.48	416500104500	50	48	33	M20	1.6
	DIN2080-A45 MHD'63.56	416630104500	63	56	41		1.9
	DIN2080-A45 MHD'80.66	416800104500	80	66	-		2.2
50	DIN2080-A50 MHD'50.48	416500105000	50	48	33	M24	2.6
	DIN2080-A50 MHD'63.56	416630105000	63	56	41		2.7
	DIN2080-A50 MHD'80.60	416800105000	80	60	45		3.2

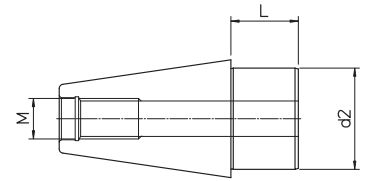
250

240



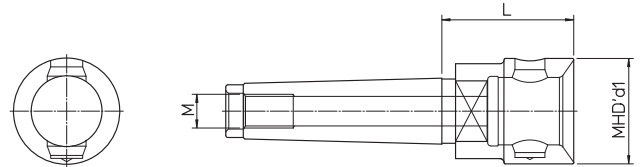
- ARBORS
- GRUNDAUFNAHMEN
- ACOPLAMIENTOS BASE
- MANDRINS
- ATTACCHI BASE

ISO 50 D.60  
ISO 60 D.60



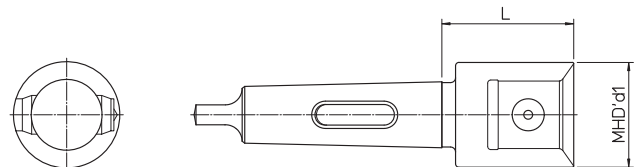
REF.	CODE	d2	L	M	Kg.
ISO 50 D.60	71ISO-50-DC6040	60	40	24	4.8
ISO 60 D.60	71ISO-60-DC6040			30	9.7

DIN 228/A 2207



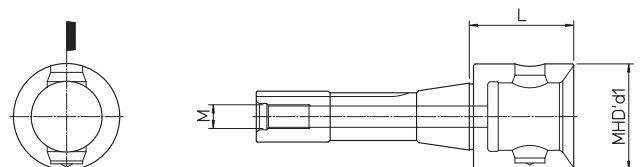
MORSE	REF.	CODE	MHD' d1	L	M	kg
4	MORSE4-A MHD'50.63	416500300400	50	63	M16	0.9
4 SIP	MORSE4-A SIP MHD'50.63	416500300401			M14	

DIN 228/B 1806



MORSE	REF.	CODE	MHD' d1	L	kg
4	MORSE4-B MHD'50.56	416500200400	50	56	0.9
5	MORSE5-B MHD'63.65	416630200500	63	65	1.5

R8



REF.	CODE	MHD' d1	L	M	kg
R 8	416500500800	50	50	M12x1.75	0.8

240

251





- ARBORS
- GRUNDAUFNAHMEN
- ACOPLAMIENTOS BASE
- MANDRINS
- ATTACCHI BASE

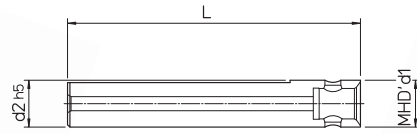


fig.1

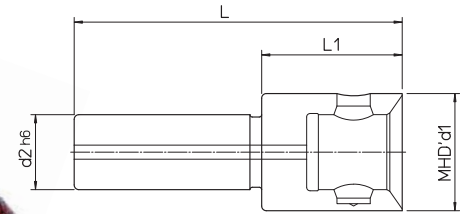
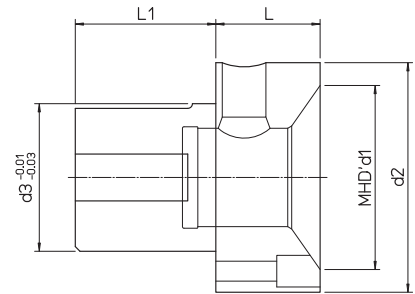
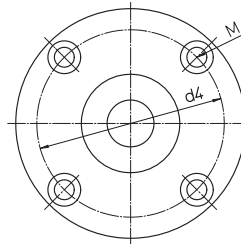


fig.2

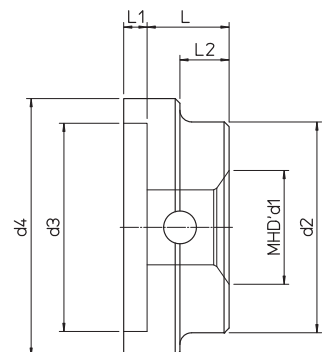
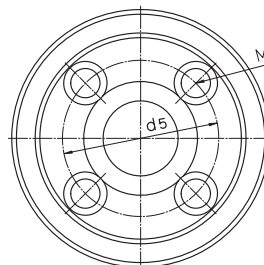
BR

REF.	CODE	MHD' d <sub>1</sub>	L	L <sub>1</sub>	d <sub>2</sub>	kg	fig.
BR 16/16.100	657081601001	16	100	-	16	0.15	1
BR 20/20.125	657082001251	20	125	-	20	0.3	
BR 25/32.35	416320802500	32	100	35	25	0.7	2
BR 32/50.60	416500803200	50	140	60	32	1	



MR

REF.	CODE	MHD' d <sub>1</sub>	d <sub>2</sub>	d <sub>3</sub>	d <sub>4</sub>	L	L <sub>1</sub>	M	kg
MR 50/80.80	450208001060	63 ~ 80	80	50	65	45	50	M6	1.5
MR 63/98.80	450209801060		98	63	80		60	M8	3.1
MR 80/130.80	450213001240		130	80	104.6		80	M10	6.1
MR 80/130.110	450213001340	110				105		9	



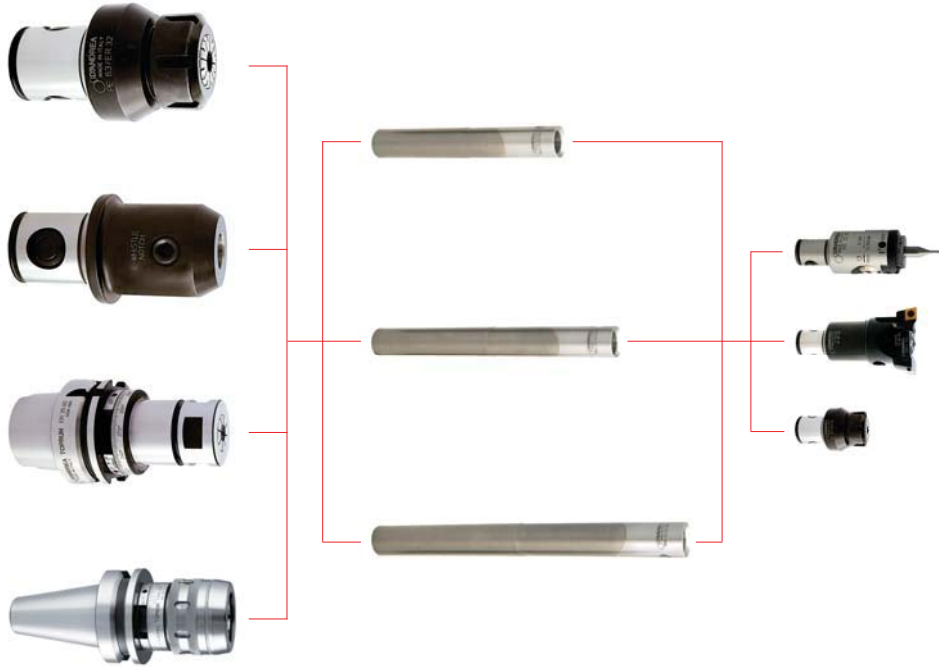
DIN 2079

REF.	CODE	MHD' d <sub>1</sub>	d <sub>2</sub>	d <sub>3</sub>	d <sub>4</sub>	d <sub>5</sub>	L	L <sub>1</sub>	L <sub>2</sub>	M	kg
DIN 2079-40.50	416502004000	50	90	88.89	110	66.7	35	10	21	M12	1.8
DIN 2079-40.63	416632004000	63					47		31		2
DIN 2079-50.63	416632005000	63	135	128.57	150	101.6	45	12	36	M16	5.4
DIN 2079-50.80	416802005000	80					50		98		5.3
DIN 2079-50.110	416912005000	110					112		98		8.4
DIN 2079-50.140	416942005000	140	140				122	108			9.5

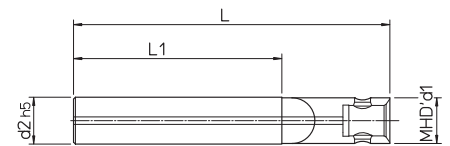


- CARBIDE BARS FOR DEEP-HOLE MACHINING
- HARTMETALL-BOHRSTANGEN FÜR TIEFLOCH-BEARBEITUNGEN
- BARRAS DE METAL DURO PARA MECANIZACIONES DE AGUJEROS PROFUNDOS
- BARRES CARBURE POUR USINAGES DE TROUS PROFONDS
- BARRE IN METALLO DURO PER LAVORAZIONI DI FORI PROFONDI

## BMD PROGRAM



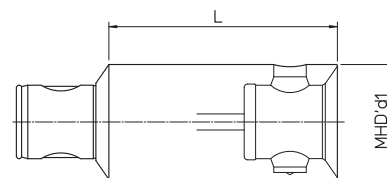
## BMD



REF.	CODE	MHD' d1	d2	L	L1	kg
BMD 16/16.110	657081601105	16	16	110	70	0.3
BMD 16/16.140	657081601405			140	100	0.4
BMD 16/16.170	657081601705			170	130	0.5
BMD 20/20.135	657082001355	20	20	135	89	0.6
BMD 20/20.170	657082001705			170	124	0.75
BMD 20/20.210	657082002105			210	164	0.9
BMD 25/25.160	657082501605	25	25	160	107	1
BMD 25/25.205	657082502055			205	152	1.3
BMD 25/25.255	657082502555			255	202	1.6
BMD 32/32.195	657083201955	32	32	195	130	2.1
BMD 32/32.250	657083202505			250	185	2.8
BMD 32/32.315	657083203155			315	250	3.5

- EXTENSIONS
- VERLÄNGERUNGEN
- PROLONGACIONES
- RALLONGES
- PROLUNGHE

PR



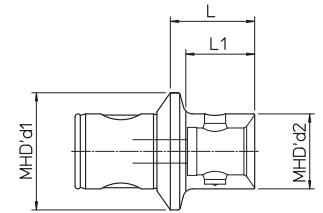
REF.	CODE	MHD' d <sub>1</sub>	L	kg
PR 14.25	656901400250	14	25	0.02
PR 16.25	656901600250	16		0.04
PR 20.32	656902000320	20	32	0.07
PR 25.25	656902500250	25	25	0.09
PR 25.40	656902500400		40	0.15
PR 32.32	656903200320	32	32	0.2
PR 32.50	656903200500		50	0.3
PR 40.40	656904000400	40	40	0.4
PR 40.63	656904000630		63	0.6
PR 50.50	656905000500	50	50	0.7
PR 50.80	656905000800		80	1.1
PR 50.100	656905001000		100	1.5
PR 63.63	656906300630	63	63	1.4
PR 63.100	656906301000		100	2.2
PR 63.125	656906301250		125	2.9
PR 80.80	656908000800	80	80	3
PR 80.125	656908001250		125	4.6
PR 80.160	656908001600		160	6.1
PR 110.140	656911001400	110	140	13.5
PR 110.200	656911002000		200	14.3
PR 140.140	656914001400	140	140	24
PR 140.250	656914002500		250	28.5





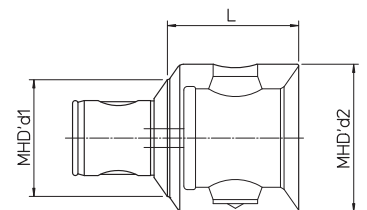
- REDUCTIONS
- REDUZIERUNGEN
- REDUCCIONES
- RÉDUCTIONS
- RIDUZIONI

RD



REF.	CODE	MHD' d1	MHD' d2	L	L1	kg
RD 16/14.25	657001600140	16	14	25	19.5	0.02
RD 20/14.20	657002000140	20		20	14.5	0.03
RD 20/16.20	657002000160		16	25	16	0.05
RD 25/14.20	657002500140	14	13.5		0.06	
RD 25/16.20	657002500160	16	15		0.07	
RD 25/20.25	657002500200	20	20	20	0.08	
RD 32/14.25	657003200140	32	14	25	17.5	0.08
RD 32/16.24	657003200160		16	24	18	0.10
RD 32/20.25	657003200200		20	25	20	0.12
RD 32/25.28	657003200250		25	28	23	0.14
RD 40/14.25	657004000140	40	14	25	16.5	0.10
RD 40/16.24	657004000160		16	24	17	0.18
RD 40/20.26	657004000200		20	26	20	0.2
RD 40/25.28	657004000250		25	28	22	0.25
RD 40/32.32	657004000320		32	32	27	0.3
RD 50/14.25	657005000140		50	14	25	14.5
RD 50/14.40	657005000142	40		29.5	0.1	
RD 50/16.24	657005000160	16		24	15	0.34
RD 50/20.26	657005000200	20		26	18	0.37
RD 50/25.28	657005000250	25		28	21	0.4
RD 50/32.32	657005000320	32		32	25	0.45
RD 50/40.36	657005000400	40		36	30	0.5
RD 63/50.40	657006300500	63	50	40	34	0.9
RD 80/50.45	657008000500	80		45	36	1.2
RD 80/63.60	657008000630		63	60	52	1.7
RD 110/80.70	657011000800	110	80	70	52	6
RD 140/80.70	657014000800	140		49	7.8	

RD

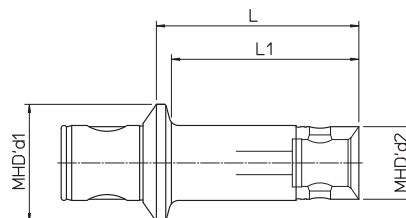


REF.	CODE	MHD' d1	MHD' d2	L	kg
RD 50/63.56	657005000630	50	63	56	1.1



- REDUCTIONS
- REDUZIERUNGEN
- REDUCCIONES
- RÉDUCTIONS
- RIDUZIONI

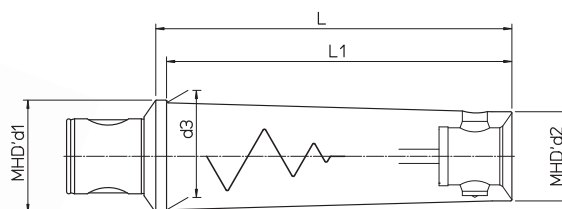
RD



REF.	CODE	MHD' d1	MHD' d2	L	L1	kg
RD 50/16.40	657005000162	50	16	40	32	0.2
RD 50/16.74	657005000163			74	65	0.25
RD 50/20.70	657005000202		20	70	62	0.3
RD 50/20.93	657005000203			93	85	0.35
RD 50/25.87	657005000252		25	87	80	0.6
RD 50/25.117	657005000253			117	110	0.65
RD 50/32.87	657005000322		32	87	80	0.75
RD 50/32.144	657005000323			144	137	1
RD 50/40.87	657005000402		40	87	80	0.9
RD 50/40.176	657005000403			176	170	1.8

- VIBRATION-DAMPING REDUCTIONS
- VIBRATIONSARME REDUZIERUNGEN
- REDUCCIONES ANTI-VIBRACIÓN
- RÉDUCTIONS ANTI-VIBRATOIRES
- RIDUZIONI ANTIVIBRANTI

RAV

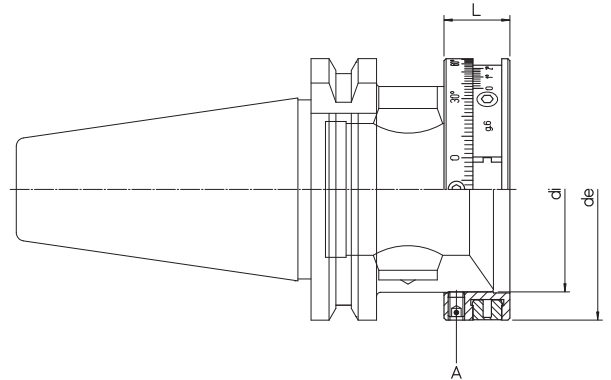


REF.	CODE	MHD' d1	MHD' d2	d3	L	L1	kg
RAV 50/16.74	657005000165	50	16	17.5	74	65	0.4
RAV 50/20.93	657005000205		20	21.5	93	85	0.5
RAV 50/25.117	657005000255		25	27	117	110	0.8
RAV 50/32.144	657005000325		32	35	144	138	1.4
RAV 50/40.176	657005000405		40	47	176	170	2.5
RAV 63/50.220	657006300505	63	50	60	220	214	5.6
RAV 80/63.280	657008000635	80	63	77	280	272	10.6



- BALANCING RINGS
- AUSWUCHTRINGE
- ANILLOS DE EQUILBRADO
- BAGUES D'ÉQUILIBRAGE
- ANELLI DI BILANCIATURA

BLC



REF.	CODE	MHD'	de	di (G6)	L
BLC 42.32	381725032001	32	42	31.5	14
BLC 50.40	381725040001	40	50	39.5	15
BLC 63.50	381725050001	50	63.5	49.8	16
BLC 80.63	381725063001	63	80	62.8	18

**GB** The BLC balancing ring, only by setting the two incorporated graduated counterweights, allows to balance, in an accurate and economical way, the toolholder on which it is mounted. The use of the BLC ring provides the following advantages: improved accuracy and surface finish; considerable extension of tool life; considerable extension of spindle bearings life; drastic reduction of vibrations and noise level in the machining centre.

**ASSEMBLY:** Remove the plastic guard ring; insert the BLC ring and lock the A screws.

**D** Der Auswuchtring BLC mit integrierten und beweglichen Gewichten ermöglicht es, den Werkzeughalter, an dem der Ring montiert ist, genau und wirtschaftlich auszuwuchten. Die Verwendung des BLC Auswuchtrings an Werkzeughaltern bietet folgende Vorteile: verbesserte Genauigkeit und Oberflächenfertigung (Qualität); merkbar höhere Lebensdauer der Werkzeuge und Schneidwerkzeuge; Schonung der Spindellager, dadurch deutlich höhere Lebensdauer; erhebliche Verminderung von Vibrationen und Geräuschen am Arbeitsplatz.

**MONTAGE:** Schutzring aus Kunststoff entfernen; Auswuchtring BLC einsetzen und Schrauben A spannen.

**E** El anillo de equilibrado BLC, con el simple posicionamiento de los dos contrapesos graduados incorporados, permite equilibrar, en forma precisa y económica, el portaherramientas en el cual va montado. La utilización del anillo BLC da las siguientes ventajas: mejora la precisión y la calidad de las superficies mecanizadas; aumenta la duración de la herramienta; prolonga la vida del husillo del centro de mecanizado; reduce las vibraciones y la rumorosidad del centro de mecanizado.

**MONTAJE:** Quitar el anillo de protección de plástico; insertar anillo BLC y fijar los tornillos A.

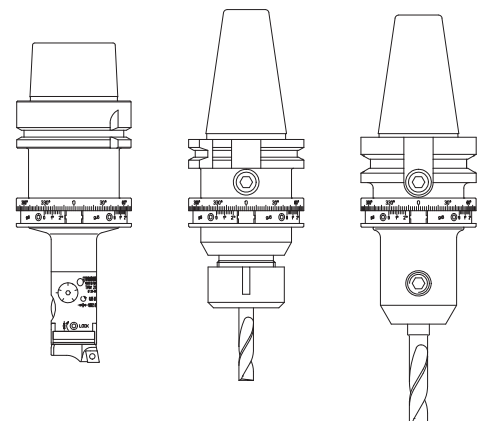
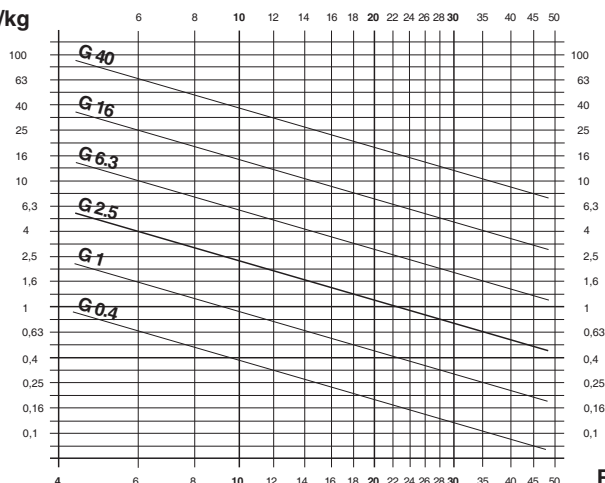
**F** La bague d'équilibrage BLC, par simple réglage des deux contrepoids gradués incorporés, permet d'équilibrer le porte-outil d'une manière précise et économique. L'utilisation de la bague BLC apporte les avantages suivants: amélioration de la précision et meilleur état de surface; meilleure durée de vie de l'outil; meilleure durée de vie des roulements de broche; réduction des vibrations et des phénomènes de bruit.

**MONTAGE:** Enlever la bague de protection en plastique; insérer la bague BLC et bloquer les clefs A.

**I** L'anello di bilanciatura BLC, con il semplice posizionamento dei due tasselli graduati incorporati, permette di equilibrare, in modo preciso ed economico, il portautensile nel quale lo stesso viene montato. L'utilizzo dell'anello BLC dà i seguenti vantaggi: migliora la precisione e la qualità delle superfici lavorate; aumenta la durata dell'utensile; allunga la vita del mandrino del centro di lavoro; riduce le vibrazioni e la rumorosità del centro di lavoro.

**MONTAGGIO:** Togliere l'anello di protezione in plastica; inserire l'anello BLC e bloccare le viti A.

e = g.mm/kg



RPM x 1000



### testarossa d'andrea

TS

TR-E

TRM

TRM HSB

2  $\mu$ m

2  $\mu$ m

2  $\mu$ m

• TS 16/16  
Ø 18 ~ 22



p.38

• TRM 16  
Ø 18 ~ 23



p.62

• TS 20/20  
Ø 22 ~ 28



p.38

• TRM 20  
Ø 22 ~ 29



p.62

• TS 25/25  
Ø 28 ~ 38



p.38

• TRM 25  
Ø 28 ~ 38



p.62

• TS 32/32  
Ø 35.5 ~ 50



p.38

• TR-E 32  
Ø 35.5 ~ 51.5



p.46

• TRM 32  
Ø 35.5 ~ 51.5



p.62

• TRM 32 HSB  
Ø 2.5 ~ 18



p.108

• TS 40/40  
Ø 50 ~ 68



p.38

• TR-E 40  
Ø 48 ~ 64



p.47

• TRM 40  
Ø 48 ~ 63



p.62

• TS 50/50  
Ø 68 ~ 90



p.39

• TS 50/63  
Ø 90 ~ 120



p.39

• TR-E 50  
Ø 2.5 ~ 110



p.48

• TRM 50  
Ø 2.5 ~ 108



p.64

• TRM 50/63  
Ø 2.5 ~ 125



p.68

• TRM 50/80  
Ø 2.5 ~ 160



p.72

• TRM 50 HSB  
Ø 2.5 ~ 22



p.110

• TS 63/63  
Ø 90 ~ 120



p.39

• TR-E 63  
Ø 6 ~ 125



p.52

• TRM 63/63  
Ø 2.5 ~ 125



p.68

• TS 80/80  
Ø 120 ~ 200



p.39

• TR-E 80  
Ø 6 ~ 200



p.56

• TRM 80/80  
Ø 2.5 ~ 160



p.72

• TRM 80/125  
Ø 36 ~ 500



p.76



# BORING SYSTEM

## TRC

• **TRC 14**  
 Ø 14.5 ~ 18  
 p.92

• **TRC 16**  
 Ø 18 ~ 24  
 p.92

• **TRC 20**  
 Ø 22 ~ 30  
 p.92

• **TRC 25**  
 Ø 28 ~ 40  
 p.92

• **TRC 32**  
 Ø 35.5 ~ 53.5  
 p.92

• **TRC 40**  
 Ø 48 ~ 66  
 p.92

• **TRC 50**  
 Ø 2.5 ~ 110  
 p.94

• **TRC 63**  
 Ø 6 ~ 125  
 p.98

• **TRC 80**  
 Ø 6 ~ 200  
 p.102

## TRC HS TRD

• **TRD 25**  
 Ø 28 ~ 36  
 p.114

• **TRC 32 HS**  
 Ø 2.5 ~ 18  
 p.108

• **TRD 32**  
 Ø 36 ~ 46  
 p.114

• **TRD 40**  
 Ø 46 ~ 60  
 p.114

• **TRC 50 HS**  
 Ø 2.5 ~ 22  
 p.110

• **TRD 50**  
 Ø 60 ~ 75  
 p.114

• **TRD 63**  
 Ø 75 ~ 95  
 p.114

• **TRD 80**  
 Ø 95 ~ 160  
 p.114

## BPS

• **TR-E 200**  
 p.86

• **TR 200**  
 p.86

• **BPS 200 - 800**  
 Ø 200 ~ 1200  
 p.82-83

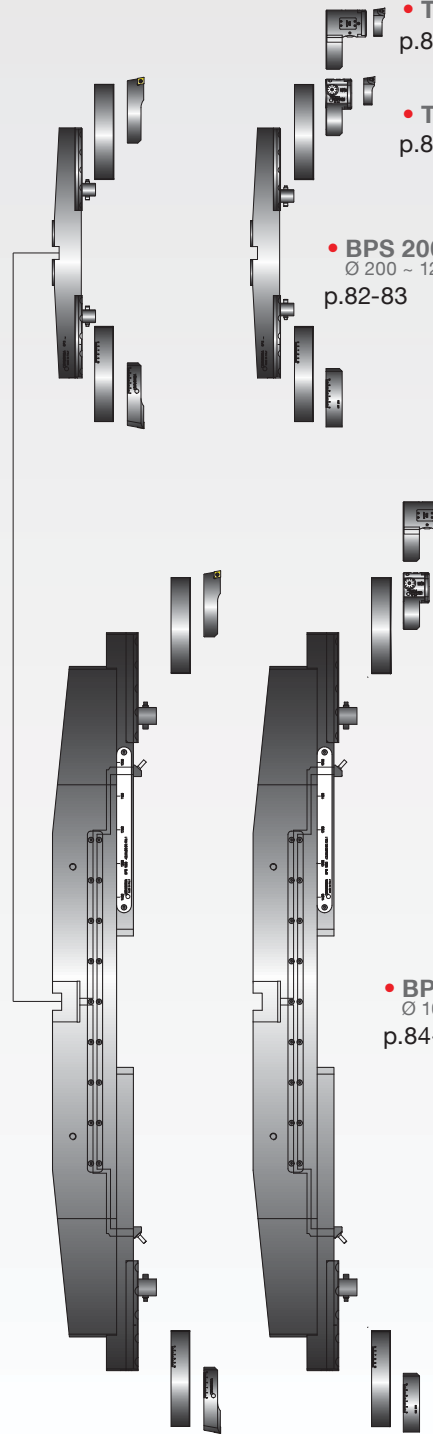
2µm

• **TR-E 200**  
 p.86

• **TR 200**  
 p.86

2µm

• **BPS 1000 - 1600 GD**  
 Ø 1000 ~ 2700  
 p.84-85



- DOUBLE-BIT HEADS
- ZWEISCHNEIDERBOHRKÖPFE
- CABEZALES DE DOS CUCHILLAS
- TÊTES À DOUBLE TRANCHANT
- TESTINE BITAGLIANTI



- 1**
- Body
  - Körper
  - Cuerpo
  - Corps
  - Corpo
- 2**
- Setting screws
  - Einstellschraube
  - Tornillo de regulación
  - Vis de réglage
  - Vite di regolazione

- 3**
- Expanding pin
  - Spreizbolzen
  - Perno radial expansible
  - Tige radiale expansible
  - Perno radiale espandibile
- 4**
- Coolant outlets
  - Kühlmittelaustritt
  - Agujeros salida refrigerante
  - Sortie du liquide d'arrosage
  - Fori uscita refrigerante
- 5**
- Bit holders
  - Plattenhalter
  - Portaplaquita
  - Porte-plaquettes
  - Seggio portainseriti
- 6**
- Tools clamp screws
  - Werkzeugklemmschrauben
  - Tornillos bloqueo herramienta
  - Vis blocage outil
  - Viti bloccaggio utensile

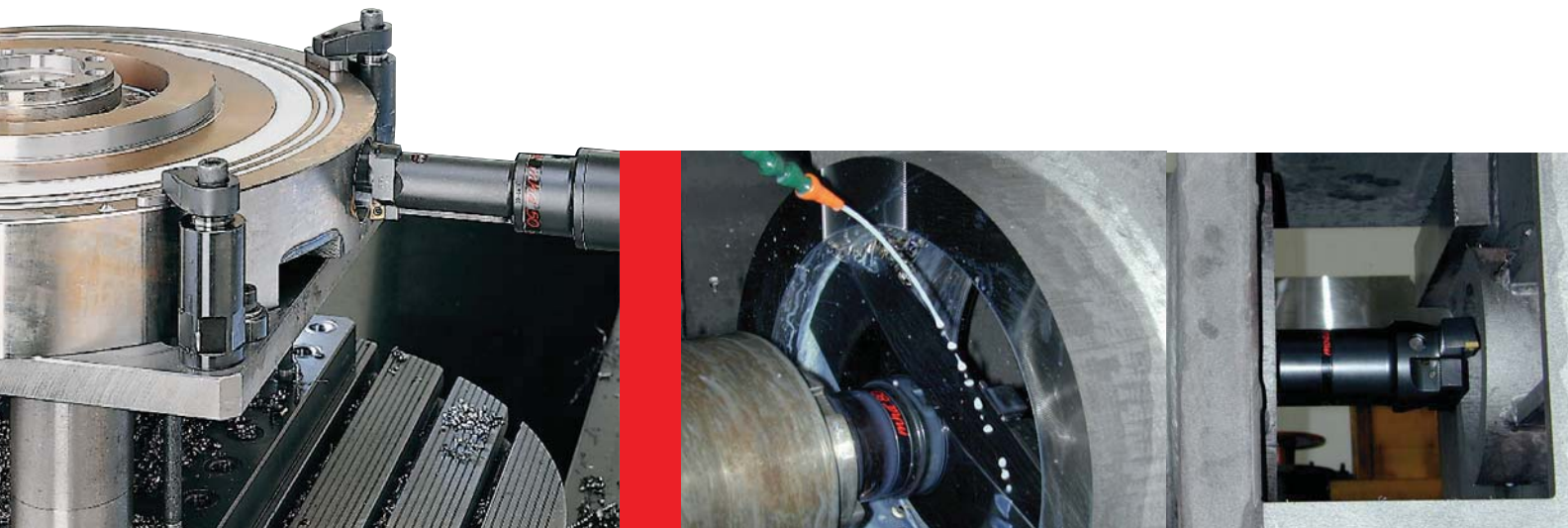
**GB** The double-bit heads are easy and extremely rigid thanks to the extensive area serrated with contacts between the bit holder and upper insert holder and the heads, together with the constant distance between the seat of the clamping screws and the cutter.

**D** Die Zweischniderköpfe sind aufgrund des einfachen Aufbaus und der großen, verzahnten Kontaktfläche zwischen Plattenhalter und Kopf zusammen mit dem gleichbleibenden Abstand zwischen Wendepaltensitz und Plattenhalterklemmung extrem stabil.

**E** Los cabezales de dos cuchillas son sencillos y extremadamente rígidos gracias a las amplias superficies dentadas de contacto entre los asientos porta-plaquitas y los cabezales mismos, así como a la distancia constante entre los tornillos de sujeción del asiento y el filo de corte.

**F** Les têtes à double tranchant sont simples et extrêmement rigides grâce aux grandes surfaces dentelées de contact entre les logements porte-plaquette et les têtes elles-mêmes, ainsi qu'à la distance constante entre la vis de serrage du logement et le tranchant.

**I** Le testine bitaglienti sono semplici ed estremamente rigide grazie alle ampie superfici dentellate di contatto tra i seggi portainserito e le testine stesse, unitamente alla distanza costante tra la vite di serraggio del seggio ed il tagliente.



- DOUBLE-BIT HEADS
- ZWEISCHNEIDERBOHRKÖPFE
- CABEZALES DE DOS CUCHILLAS
- TÊTES À DOUBLE TRANCHANT
- TESTINE BITAGLIENTI

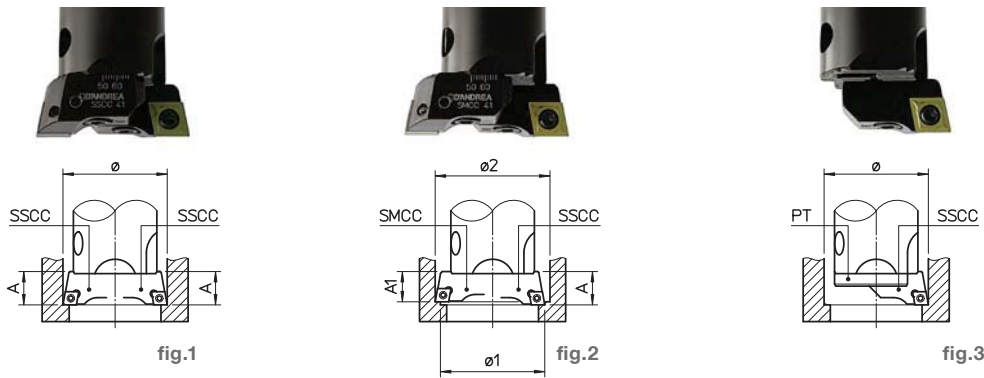
**GB USE.** The radial setting of the cutting edges should be carried out with tool presetting equipment. The boring bars are fitted with two bit holders for roughing operations involving heavy chip removal. The double-bit boring bars may include:

**D EINSATZ.** Die DurchmesserEinstellung der Wendepplatten ist auf einem Maschinenwerkzeug-voreinstellgerät vorzunehmen. Mit zwei Plattenhaltern werden die Köpfe für Schrupperarbeiten mit starker Spanabnahme verwendet. Diese Köpfe können umfassen:

**E EMPLEO.** La regulación diametral de los cortes se efectúa sobre un banco presetting para herramientas. Se utilizan con dos asientos para operaciones de desbaste con fuerte arranque de viruta. Los cabezales de dos cuchillas pueden estar compuestos con:

**F EMPLOI.** Effectuer le réglage radial des plaquettes sur un appareil de pré-réglage d'outils. Avec deux porte-plaquettes, les barres sont utilisées pour des opérations d'ébauchage avec fort enlèvement de copeaux. Ces barres d'alésage peuvent comprendre:

**I IMPIEGO.** La regolazione diametrale dei taglienti va eseguita su un banco di presetting di utensili. Si utilizzano con due seggi per operazioni di sgrossatura con forti asportazioni. I baren bitaglianti possono essere composti con:



**fig. 1** **GB** two SSCC bit holders on the same plane and with the two cutting edges set at identical radial distance for high feed rate roughing operations.

**D** zwei Plattenhalter SSCC auf gleicher Höhe mit der Schneidkante der Wendepplatten auf gleichem Durchmesser einstellen. Für Schrupperarbeiten mit großem Vorschub.

**E** dos asientos SSCC alineados y con la punta de la plaquita sobre el mismo diámetro para operaciones de desbaste con fuertes avances.

**F** deux porte-plaquettes SSCC dans le même plan avec les coupants réglés sur le même diamètre pour l'ébauchage à haute vitesse d'avance.

**I** due seggi SSCC allineati e con la punta degli inserti sullo stesso diametro per operazioni di sgrossatura con forti avanzamenti.

**fig. 2** **GB** an SSCC bit holder and an SMCC bit holder not at the same plane and with the two cutting edges set at different radial distances for high cutting depth roughing operations.

**D** je einen Plattenhalter SSCC und SMCC auf verschiedener Höhe mit der Schneidkante der Wendepplatten auf verschiedenem Durchmesser einstellen für Schrupperarbeiten mit großer Spantiefe.

**E** un asiento SSCC y un asiento más bajo SMCC desalineados y con la punta de las plaquitas sobre diámetros diversos para operaciones de desbaste con fuertes profundidades de pasada.

**F** un porte-plaquette SSCC et un porte-plaquette SMCC dans deux plans avec les coupants réglés sur des différents diamètres pour l'ébauchage avec grande profondeur de passe.

**I** un seggio SSCC ed un seggio più basso SMCC disallineati e con la punta degli inserti su diametri diversi per operazioni di sgrossatura con forti profondità di passata.

**fig. 3** **GB** the boring bars are fitted with a single bit holder for roughing and finishing operations involving normal chip removal. The serrated surface protection plate PT should always be fitted.

**D** mit einem Plattenhalter werden die Bohrstangen für Schlicht- und Schrupperarbeiten mit normaler Spanabnahme verwendet. PT Schutzplatte für die Kerbzahnfläche immer aufsetzen.

**E** se utilizan con un solo asiento para operaciones de acabado y desbaste con normal arranque de viruta. Recordar siempre montar la plaquita PT para la protección de la superficie dentada.

**F** avec un seul porte-plaquette les barres sont utilisées pour l'ébauchage et le finissage avec enlèvement de copeaux normal. Monter toujours la plaquette PT de protection de la surface dentelée.

**I** si utilizzano con un solo seggio per operazioni di finitura e sgrossatura con normali asportazioni di truciolo. Ricordarsi sempre di montare la piastrina PT per la protezione della superficie dentellata.

**TS 16/16**  
Ø 18 ~ 22



**TS 20/20**  
Ø 22 ~ 28



**TS 25/25**  
Ø 28 ~ 38



**TS 32/32**  
Ø 35.5 ~ 50



**TS 40/40**  
Ø 50 ~ 68



**TS 50/50**  
Ø 68 ~ 90



**TS 50/63**  
Ø 90 ~ 120



**TS 63/63**  
Ø 90 ~ 120



**TS 80/80**  
Ø 120 ~ 200

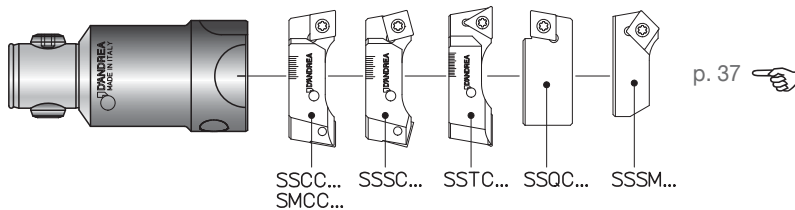




# D'ANDREA MODULHARD'ANDREA

**TS 16~40** Ø 18 ~ 68

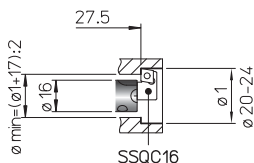
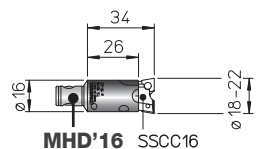
- DOUBLE-BIT HEADS
- ZWISCHNEIDERBOHRKÖPFE
- CABEZALES DE DOS CUCHILLAS
- TÊTES À DOUBLE TRANCHANT
- TESTINE BITAGLIANTI



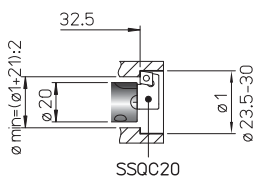
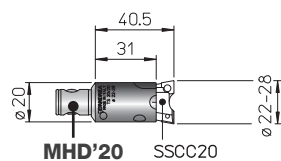
p. 37

REF.	CODE	Kg.
TS 16/16	455501600340	0.05
TS 20/20	455502000400	0.09
TS 25/25	455502500500	0.2
TS 32/32	455503200630	0.35
TS 40/40	455504000800	0.7

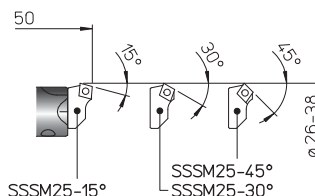
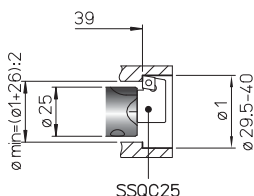
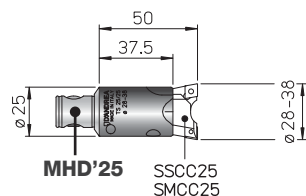
REF.	CODE	Kg.
TS 50/50	455305001000	1.5
TS 50/63	455306300800	2
TS 63/63	455406301250	3
TS 80/80	455408001400	5.3



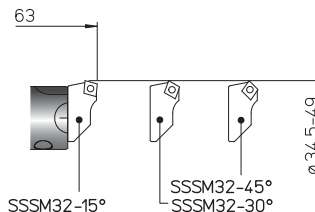
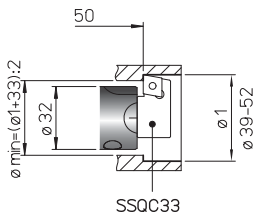
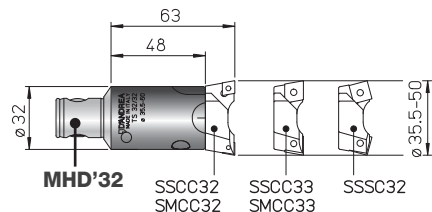
**TS 16/16**  
Ø 18 ~ 22



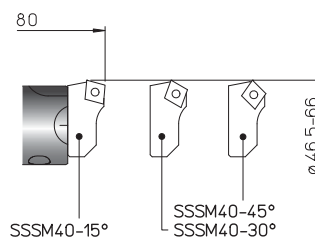
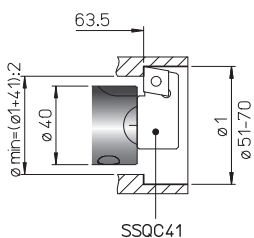
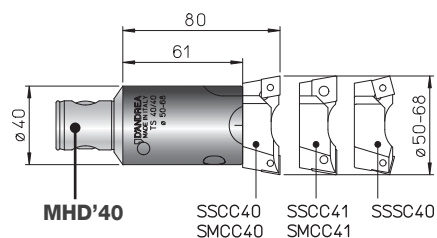
**TS 20/20**  
Ø 22 ~ 28



**TS 25/25**  
Ø 28 ~ 38



**TS 32/32**  
Ø 35.5 ~ 50



**TS 40/40**  
Ø 50 ~ 68

118

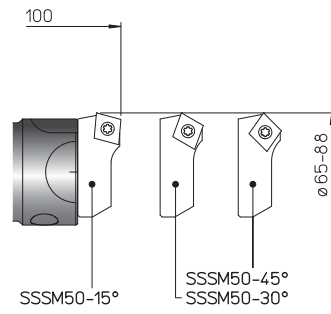
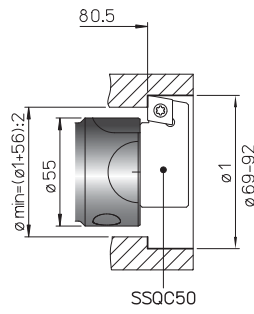
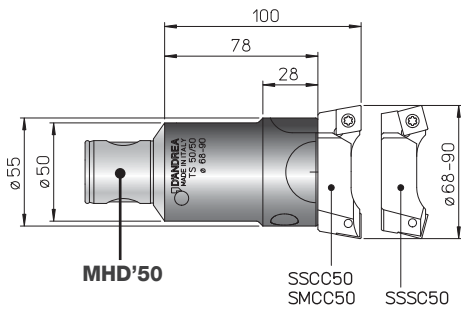
120

116

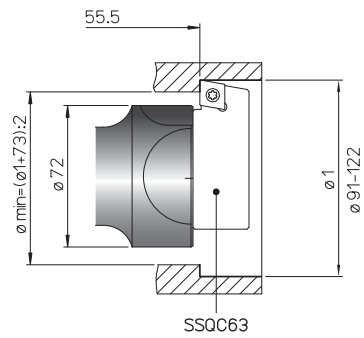
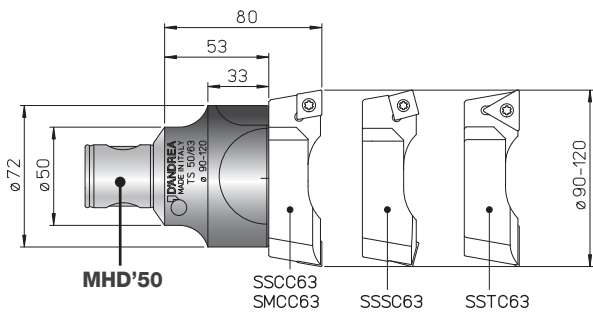


# TS 50~80 Ø 68 ~ 200

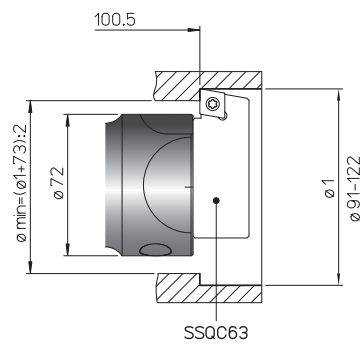
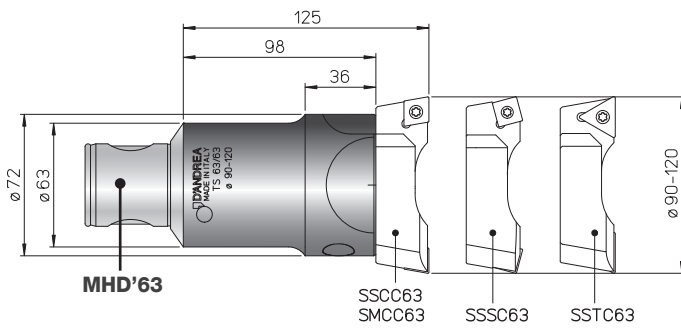
- DOUBLE-BIT HEADS
- ZWEISCHNEIDERBOHRKÖPFE
- CABEZALES DE DOS CUCHILLAS
- TÊTES À DOUBLE TRANCHANT
- TESTINE BITAGLIANTI



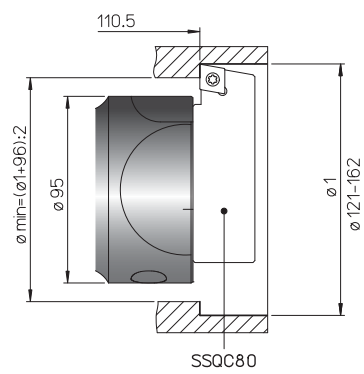
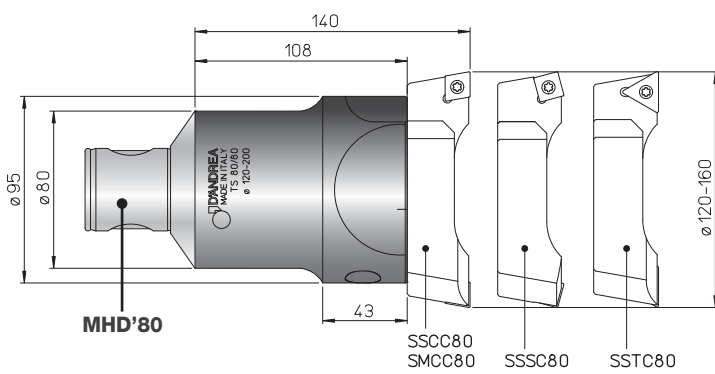
**TS 50/50**  
Ø 68 ~ 90



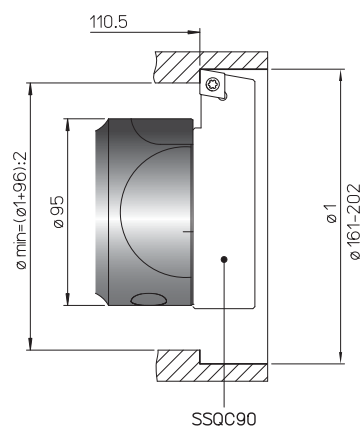
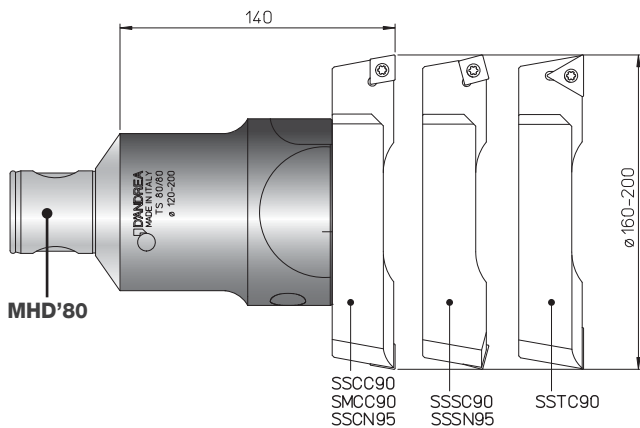
**TS 50/63**  
Ø 90 ~ 120



**TS 63/63**  
Ø 90 ~ 120



**TS 80/80**  
Ø 120 ~ 160



Ø 160 ~ 200

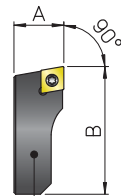
# D'ANDREA

## MODULHARD'ANDREA

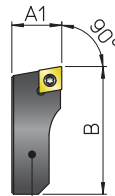
40

- BIT-HOLDERS FOR DOUBLE-BIT ITEMS
- PLATTENHALTER FÜR ZWEISCHNEIDERWERKZEUGE
- PORTAPLAQUITAS PARA ASIENTOS A DOS CUCHILLAS
- PORTE-PLAQUETTES POUR PRODUITS À DEUX COUPANTS
- SEGGI PER BITAGLIENTI

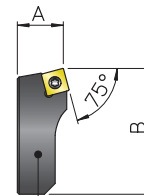
SSCC - SMCC - SSSC



SSC...



SMCC...

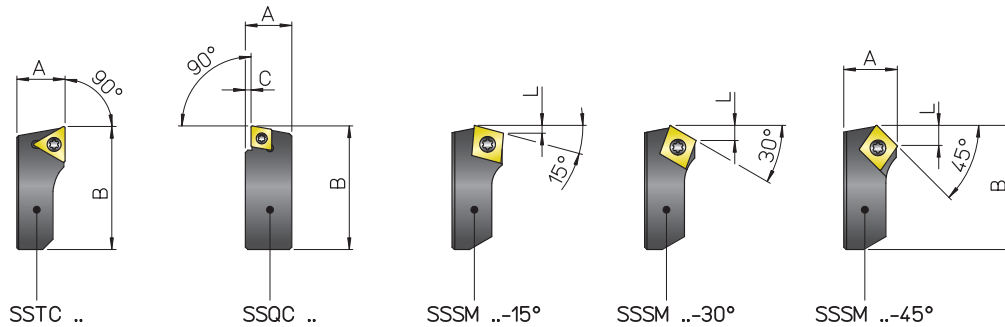


SSS...

REF.	CODE	A	A1	B					Kg.
<b>SSCC 16</b>	470500516201	8		15	CCMT 0602..	-	TS 25	TORX T08	0.003
<b>SSCC 20</b>	470500520201	9.5		19					0.006
<b>SSCC 25</b>	470500525201	12.5	-	23					0.01
<b>SSCC 32</b>	470500532201	15		32	CCMT 09T3..	-	TS 4	TORX T15	0.02
<b>SSCC 33</b>	470500532204								
<b>SSCC 40</b>	470500540201	19		40					0.06
<b>SSCC 41</b>	470500540204								
<b>SSCC 50</b>	470500550204	22		54	CCMT 1204..	-	TS5	TORX T25	0.1
<b>SSCC 63</b>	470500563201	27	-	70.5					0.2
<b>SSCC 80</b>	470500580201	32		94.5					0.5
<b>SSCC 90</b>	470500590201			130					0.7
<b>SSCN 95</b>	470500595201	40			CNM. 1906..		p. 126		0.9
<b>SMCC 25</b>	470500525203	-	12.3	23	CCMT 0602..	-	TS 25	TORX T08	0.01
<b>SMCC 32</b>	470500532203		14.8	32					0.02
<b>SMCC 33</b>	470500532205	-			CCMT 09T3..	-	TS 4	TORX T15	0.025
<b>SMCC 40</b>	470500540203		18.7	40					0.06
<b>SMCC 41</b>	470500540205								0.06
<b>SMCC 50</b>	470500550205		21.7	54					0.1
<b>SMCC 63</b>	470500563203	-	26.7	70.5	CCMT 1204..	-	TS 5	TORX T25	0.2
<b>SMCC 80</b>	470500580203		31.7	94.5					0.5
<b>SMCC 90</b>	470500590203			130					0.7
<b>SSSC 32</b>	470500532202	15		32		SCMT 09T3..	TS 4	TORX T15	0.02
<b>SSSC 40</b>	470500540202	19		40					0.06
<b>SSSC 50</b>	470500550202	22		54					0.1
<b>SSSC 63</b>	470500563202	27		70.5		SCMT 1204..	TS 5	TORX T25	0.2
<b>SSSC 80</b>	470500580202	32		94.5					0.5
<b>SSSC 90</b>	470500590202			130					0.7
<b>SSSN 95</b>	470500595202	40			SNM. 1906..		p. 126		0.9



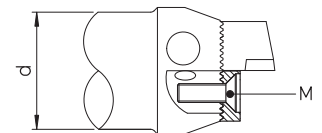
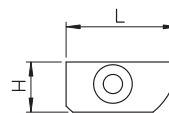
- BIT-HOLDERS FOR DOUBLE-BIT ITEMS
- PLATTENHALTER FÜR ZWEISCHNEIDERWERKZEUGE
- PORTAPLAQUITAS PARA ASIENTOS A DOS CUCHILLAS
- PORTE-PLAQUETTES POUR PRODUITS À DEUX COUPANTS
- SEGGI PER BITAGLIANTI



REF.	CODE	A	B	C	L	△	□	⌢	🔧	Kg.
SSTC 63	470500563206	27	70.5	-	-	TCMT 2204..	-	TS 5	TORX T25	0.2
SSTC 80	470500580206	32	94.5	-	-	TCMT 2204..	-	TS 5	TORX T25	0.5
SSTC 90	470500590206		130	0.7						
SSQC 16	470500516261	10	16	2	-	-	CCMT 0602..	TS 25	TORX T08	0.005
SSQC 20	470500520261	11	19.5	1.5	-	-	CCMT 0602..	TS 25	TORX T08	0.008
SSQC 25	470500525261	14.5	24	2.5	-	-				0.02
SSQC 33	470500533261	17	32	3	-	-	CCMT 09T3..	TS 4	TORX T15	0.03
SSQC 41	470500541261	21	42	3.5	-	-	CCMT 1204..	TS 5	TORX T25	0.08
SSQC 50	470500550261	24.5	57							0.15
SSQC 63	470500563261	28.5	76							0.3
SSQC 80	470500580261	31.5	101	-	-	-	CCMT 1204..	TS 5	TORX T25	0.6
SSQC 90	470500590261		122							0.8
SSSM 25-15°	470500525211	12.5	23	-	1.6	-	CCMT 0602..	TS 25	TORX T08	0.01
SSSM 25-30°	470500525213				3					
SSSM 25-45°	470500525215				4.3					
SSSM 32-15°	470500532211	15	31	-	1.6	-	CCMT 09T3..	TS 4	TORX T15	0.025
SSSM 32-30°	470500532213				3					
SSSM 32-45°	470500532215				4.3					
SSSM 40-15°	470500540211	19	39	-	2.4	-	CCMT 09T3..	TS 4	TORX T15	0.06
SSSM 40-30°	470500540213				4.6					
SSSM 40-45°	470500540215				6.5					
SSSM 50-15°	470500550211	22	53	-	3.2	-	CCMT 1204..	TS 5	TORX T25	0.1
SSSM 50-30°	470500550213				6.2					
SSSM 50-45°	470500550215				8.8					

- COVER PLATES
- ABDECKPLATTEN
- PROTECCIONES
- CACHES DE PROTECTION
- PROTEZIONI MILLERIGHE

PT



REF.	CODE	d	H	L	M
PT 16	384765000160	16	7	14	M 3x12
PT 20	384765000200	20	8.5	17	M 4x14
PT 25	384765000250	25	10.2	21	M 4x16
PT 32	384765000320	32	13.9	28	M 5x20
PT 40	384765000400	40	17.4	35	M 6x25
PT 50	384765000500	50	21.4	47.5	M 8x25
PT 63	384765000630	63	26.4	62	M 10x30
PT 80	384765000800	80	33.9	82.5	M 12x35





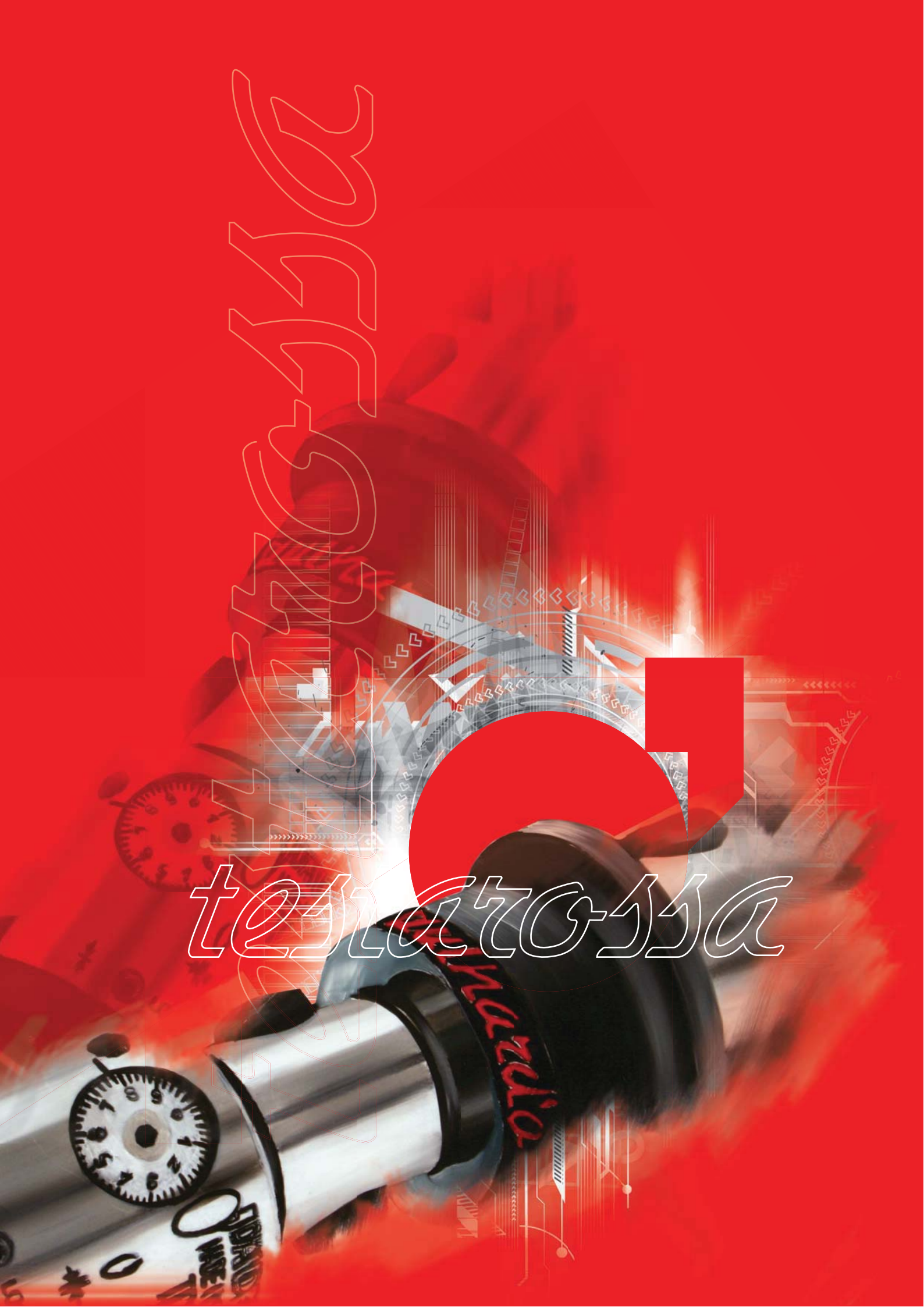
*testarossa d'andrea*

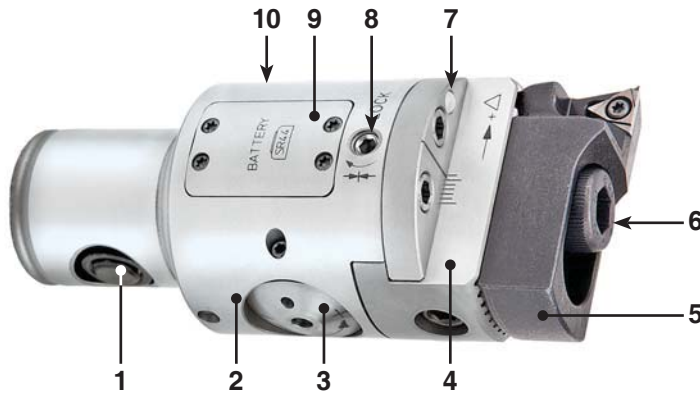
*testar*



testato

testato





- 1**
- Expanding radial pin
  - Spreizbolzen
  - Perno radial expansible
  - Tige radiale expansible
  - Perno radiale espandibile

- 2**
- Body
  - Körper
  - Cuerpo
  - Corps
  - Corpo

- 3**
- Set screw
  - Einstellschraube
  - Tornillo de ajuste
  - Vis de réglage
  - Vite di regolazione

- 4**
- Slide toolholder
  - Werkzeugschlitten
  - Guía portaherramientas
  - Coulisseau
  - Slitta portautensili

- 5**
- Bit holder
  - Plattenhalter
  - Portaplaquita
  - Porte-plaquettes
  - Seggio portainseriti

- 6**
- Tools clamp screws
  - Werkzeugklemmschrauben
  - Tornillo bloqueo herramienta
  - Vis blocage outil
  - Vite bloccaggio utensili

- 7**
- Coolant outlet
  - Kühlmittelaustritt
  - Agujero salida refrigerante
  - Sortie du liquide d'arrosage
  - Ugello uscita refrigerante

- 8**
- Slide clamp screw
  - Schlitten-Klemmschraube
  - Tornillo bloqueo guía
  - Vis blocage coulisseau
  - Vite bloccaggio slitta

- 9**
- Battery compartment cover
  - Batteriefachdeckel
  - Compartimento para baterías
  - Couvercle des batteries
  - Coperchio vano pile

- 10**
- Oiler
  - Schmiernippel Bohrstrangen
  - Engrasador
  - Graisseur
  - Oliatore

- 11**
- Digital display
  - Digitaler Bildschirm
  - Visor digital
  - Affichage numérique
  - Display digitale

- 12**
- Selection button
  - Auswahl taste
  - Botón de selección
  - Bouton de sélection
  - Pulsante di selezione

**IP67**

**2 μm**



**GB FEATURES.** The TR-ELETTRA heads enable high precision machining with tolerance grade, IT6, with excellent surface finish. They have a 1 micron radius adjustment sensitivity on a built-in digital display, ensuring maximum speed and adjustment accuracy. The TR-ELETTRA heads are resistant to water infiltration and are coated with an anti-corrosive surface protection.

**D MERKMALE.** Die TR-ELETTRA-Köpfe ermöglichen hochpräzise Bearbeitungen mit IT6-Toleranzen und optimalem Oberflächenfinish. Ihre Einstellgenauigkeit liegt bei 1 Mikron an dem auf einem integrierten digitalen Display angezeigten Radius, was ein Maximum an Schnelligkeit und Einstellgenauigkeit gewährleistet. Die TR-ELETTRA-Köpfe sind gegen Eindringen von Wasser beständig und haben an der Oberfläche eine Antikorrosionsbeschichtung.

**E CARACTERÍSTICAS.** Los cabezales TR-ELETTRA ofrecen un mecanismo de alta presión para una tolerancia de grado IT6, con un excelente acabado superficial. Tienen una sensibilidad de ajuste de una 1 micra sobre el radio incorporado en la pantalla digital, garantizando la máxima velocidad y precisión de ajuste. Las cabezales TR-ELETTRA son resistentes a la infiltración del agua y están cubiertas con una protección anticorrosiva superficial.

**F CARACTÉRISTIQUES.** Les têtes TR-ELETTRA permettent des usinages de haute précision avec des tolérances de degré IT6, comprenant un excellent finissage superficiel. Elles ont une sensibilité de réglage de 1 micron sur le rayon visualisé sur un écran intégré, garantissant une vitesse et une précision de réglage maximale. Les têtes TR-ELETTRA résistent aux infiltrations d'eau et elles sont revêtues d'une protection superficielle anticorrosion.

**I CARATTERISTICHE.** Le testine TR-ELETTRA consentono lavorazioni di alta precisione in tolleranze di grado IT6, con ottima finitura superficiale. Hanno una sensibilità di regolazione di 1 micron sul raggio visualizzato su un display digitale incorporato, garantendo la massima velocità e precisione di regolazione. Le testine TR-ELETTRA sono resistenti alle infiltrazioni d'acqua e sono rivestite con una protezione superficiale anticorrosiva.



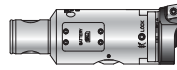
**TR-ELETTRA 32 MHD'32**

Ø 35.5 ~ 51.5



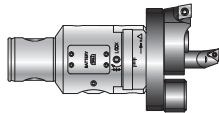
**TR-ELETTRA 40 MHD'40**

Ø 48 ~ 64



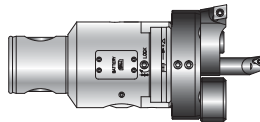
**TR-ELETTRA 50 MHD'50**

Ø 2.5 ~ 110



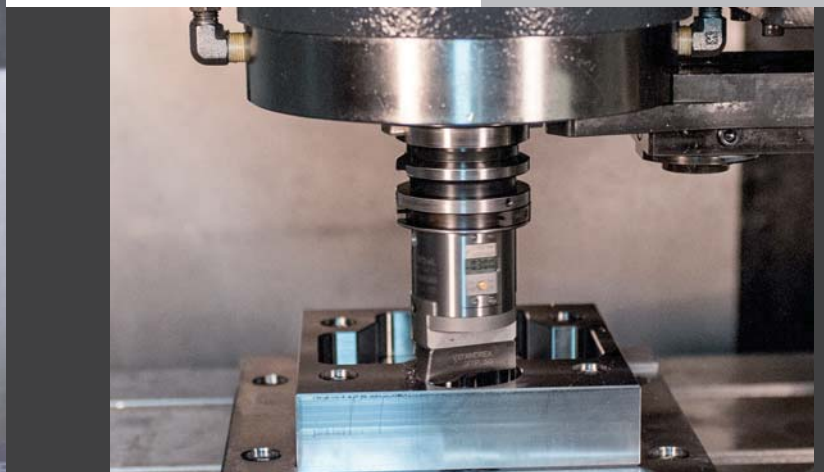
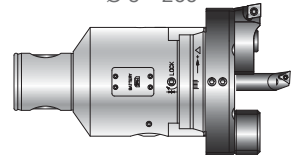
**TR-ELETTRA 63 MHD'63**

Ø 6 ~ 125



**TR-ELETTRA 80 - MHD'80**

Ø 6 ~ 200



TR-E 32 - MHD'32

TR-E 40 - MHD'40

TR-E 50 - MHD'50

TR-E 63 - MHD'63

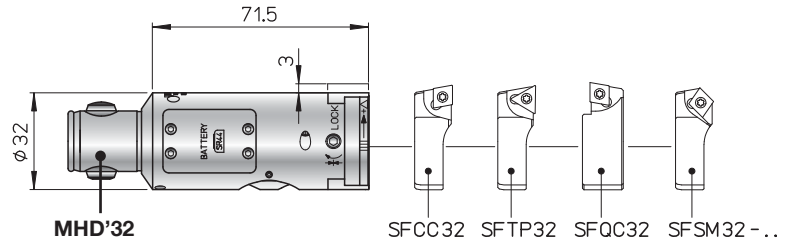
TR-E 80 - MHD'80







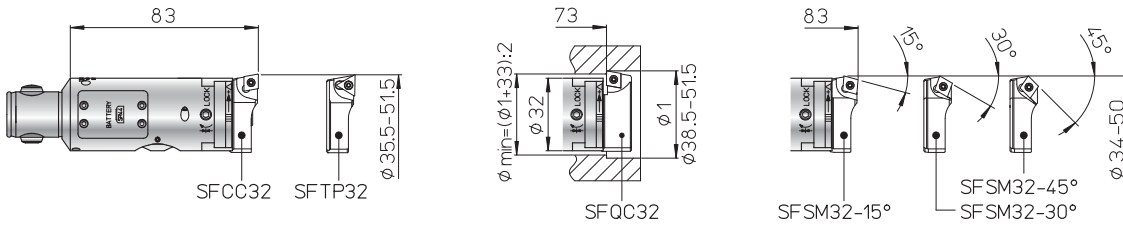
2 µm



REF.	CODE	Kg.
TR-ELETTRA 32 MHD'32	455200320320	0.4

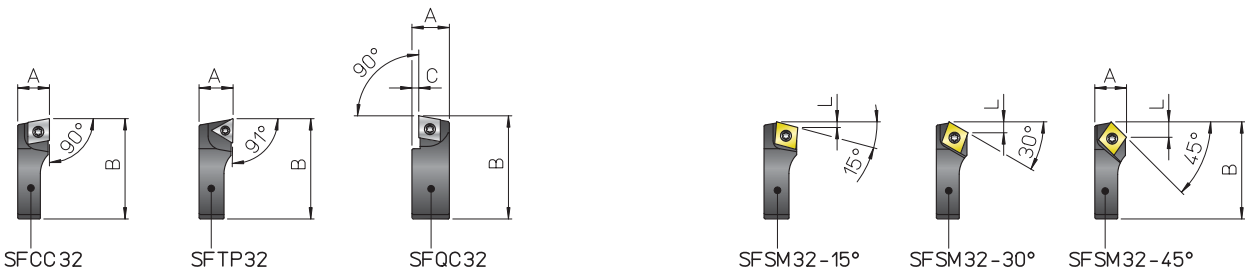
### TR-E 32

Ø 35 ~ 51.5



- BIT-HOLDERS FOR TESTAROSSA
- PLATTENHALTER FÜR TESTAROSSA
- PORTA-PLAQUITAS PARA TESTAROSSA
- PORTE-PLAQUETTES POUR TESTAROSSA
- SEGGI PER TESTAROSSA

SF

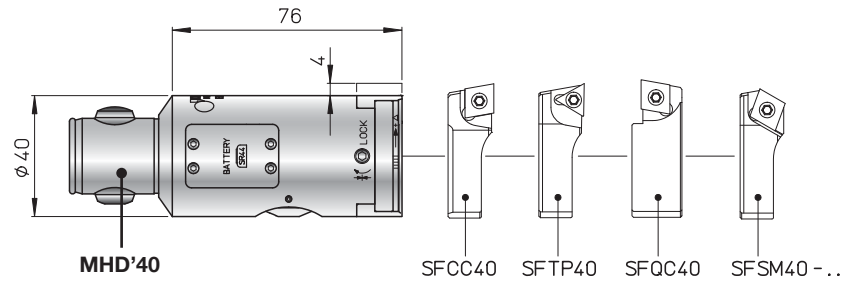


REF.	CODE	A	B	C	L	Icon 1	Icon 2	Icon 3	Icon 4	Kg.
SFCC 32	470500532002	11.5	34.5	-	-	CCGT 0602..	-	TS 25	TORX T08	0.02
SFTP 32	470500532001	11.5	34.5	-	-	-	TPGX 0902..	CS 250T	TORX T08	0.02
SFQC 32	470500532062	13.5	35.5	2.5	-	CCMT 0602..	-	TS 25	TORX T08	0.03
SFSM 32-15°	470500532011	11.5	33.5	-	1.6	CCMT 0602..	-	TS 25	TORX T08	0.02
SFSM 32-30°	470500532013				3					
SFSM 32-45°	470500532015				4.3					



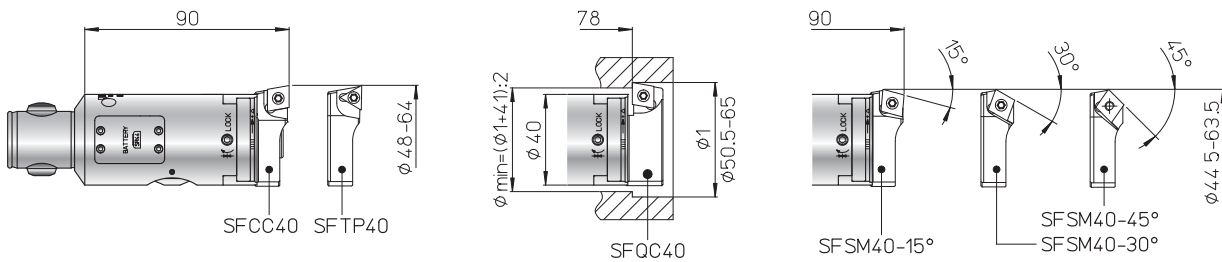


2 μm



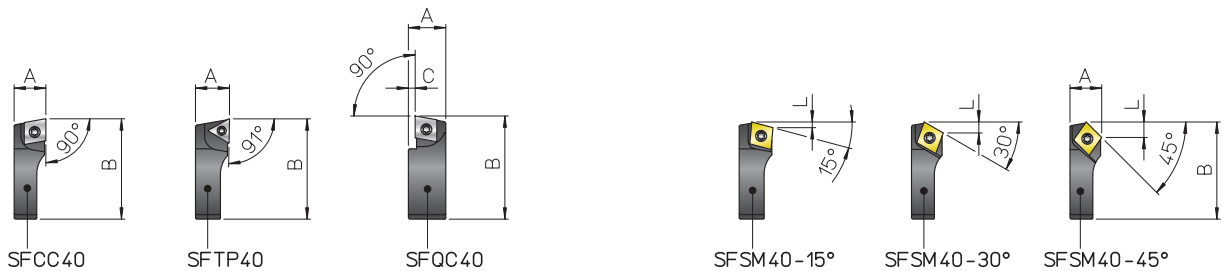
REF.	CODE	Kg.
TR-ELETTRA 40 MHD'40	455200400400	0.7

TR-E 40  
Ø 48 ~ 64



- BIT-HOLDERS FOR TESTAROSSA
- PLATTENHALTER FÜR TESTAROSSA
- PORTA-PLAQUITAS PARA TESTAROSSA
- PORTE-PLAQUETTES POUR TESTAROSSA
- SEGGI PER TESTAROSSA

SF



REF.	CODE	A	B	C	L					Kg.
SFCC 40	470500540002	14	44	-	-	CCGT 09T3..	-	TS 4	TORX T15	0.04
SFTP 40	470500540001	14	44	-	-	-	TPGX 1103..	CS 300890T	TORX T08	0.04
SFQC 40	470500540062	16.5	46	3	-	CCMT 09T3..	-	TS 4	TORXT15	0.06
SFSM 40-15°	470500540011	14	42.5	-	2.4	CCMT 09T3..	-	TS 4	TORXT15	0.03
SFSM 40-30°	470500540013				4.6					
SFSM 40-45°	470500540015				6.6					

116

120

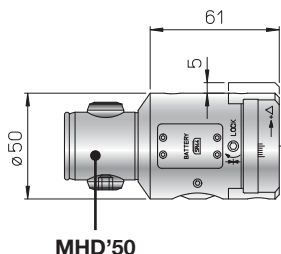
119



INFO

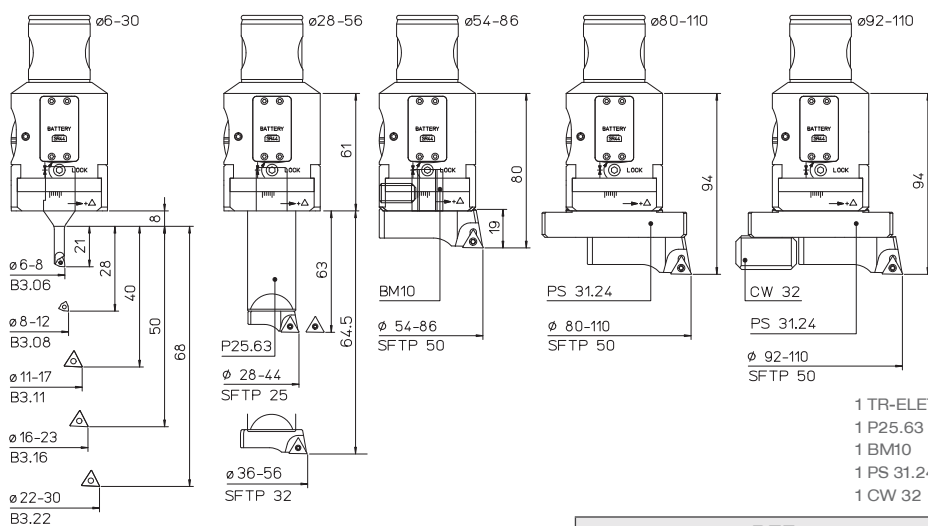
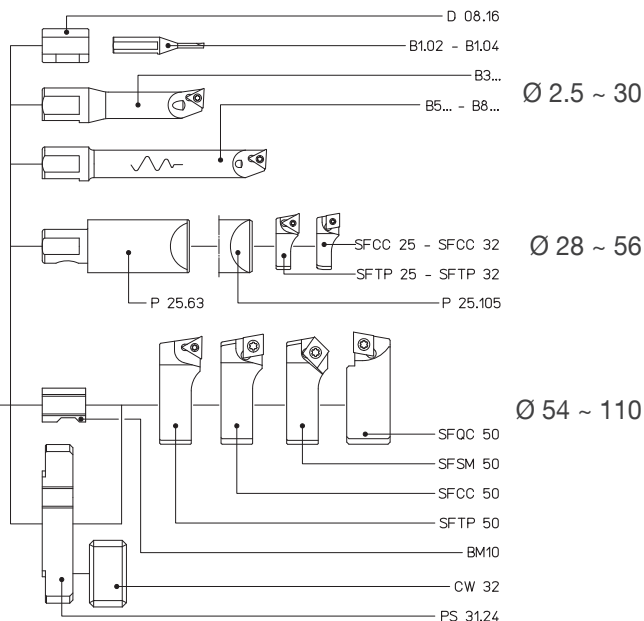


2 μm



MHD'50

REF.	CODE	Kg.
TR-ELETTRA 50 MHD'50	455200500500	1.1



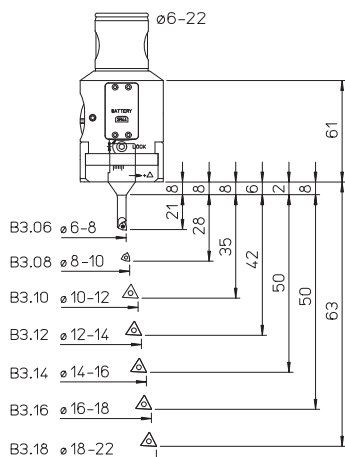
### KIT K01

Ø 6 ~ 110



- 1 TR-ELETTRA 50 MHD'50
- 1 P25.63 1 B3.06 1 B3.22 5 TPGX 090202L DC100
- 1 BM10 1 B3.08 1 SFTP25 1 TPGX 110302L DC100
- 1 PS 31.24 1 B3.11 1 SFTP32 2 WCGT 020102L DC100
- 1 CW 32 1 B3.16 1 SFTP50

REF.	CODE	Ø
KIT K01 TR-ELETTRA 50 MHD'50	655200500500	6 ~ 110



### KIT K00

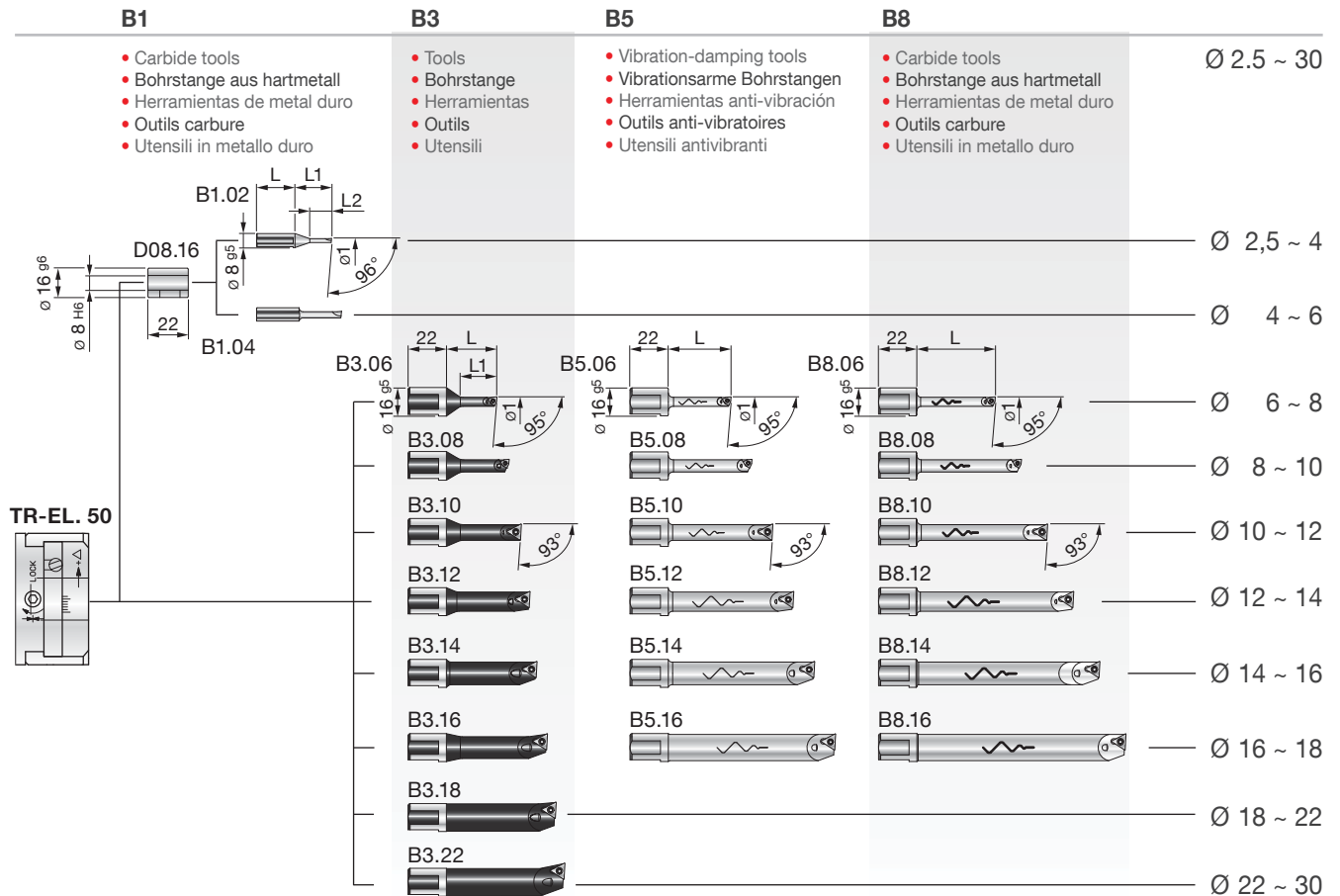
Ø 6 ~ 22



- 1 TR-ELETTRA 50 MHD'50
- 1 B3.06 1 B3.12 1 B3.18
- 1 B3.08 1 B3.14 5 TPGX 090202L DC100
- 1 B3.10 1 B3.16 2 WCGT 020102L DC100

REF.	CODE	Ø
KIT K00 TR-ELETTRA 50 MHD'50	655200500501	6 ~ 22





- B1**
- Carbide tools
  - Bohrstange aus hartmetall
  - Herramientas de metal duro
  - Outils carbure
  - Utensili in metallo duro

- B3**
- Tools
  - Bohrstange
  - Herramientas
  - Outils
  - Utensili

- B5**
- Vibration-damping tools
  - Vibrationsarme Bohrstangen
  - Herramientas anti-vibración
  - Outils anti-vibratoires
  - Utensili antivibranti

- B8**
- Carbide tools
  - Bohrstange aus hartmetall
  - Herramientas de metal duro
  - Outils carbure
  - Utensili in metallo duro

Ø 2.5 ~ 30

Ø 2,5 ~ 4

Ø 4 ~ 6

Ø 6 ~ 8

Ø 8 ~ 10

Ø 10 ~ 12

Ø 12 ~ 14

Ø 14 ~ 16

Ø 16 ~ 18

Ø 18 ~ 22

Ø 22 ~ 30

REF.	CODE	Kg.
D08.16	200560116082	0.02

REF.	CODE	Ø1	L	L1	L2	Kg.
B1.02	572010502001	2.5 ~ 4	22	21	12.5	0.02
B1.04	572010504001	4 ~ 6	24	24	-	

REF.	CODE	Ø1	L	L1	⊖	⊖	⊖	⊖	Kg.
B3.06	572010506001	6 ~ 8	29	21	WCGT 0201..	-	TS 21	TORX T06	0.035
B3.08	572010508001	8 ~ 10	36	28			TS 211		0.04
B3.10	572010510001	10 ~ 12	43	35	-	TPGX 0902..	CS 250 T	TORX T08	0.05
B3.11	572010511001	11 ~ 13	48	40					0.055
B3.12	572010512001	12 ~ 14	42	42					0.06
B3.14	572010514001	14 ~ 16	52	50					0.07
B3.16	572010516001	16 ~ 18	58	-	-	-	-	-	0.1
B3.18	572010518001	18 ~ 22	63	-					
B3.22	572010522001	22 ~ 30	68	-					

B5.06	572010506105	6 ~ 8	36	-	WCGT 0201..	-	TS 21	TORX T06	0.075
B5.08	572010508105	8 ~ 10	48				TS 211		0.09
B5.10	572010510105	10 ~ 12	60	-	TPGX 0902..	CS 250 T	TORX T08	0.1	
B5.12	572010512105	12 ~ 14	72					0.2	
B5.14	572010514105	14 ~ 16	84					0.3	
B5.16	572010516105	16 ~ 18	96					0.3	

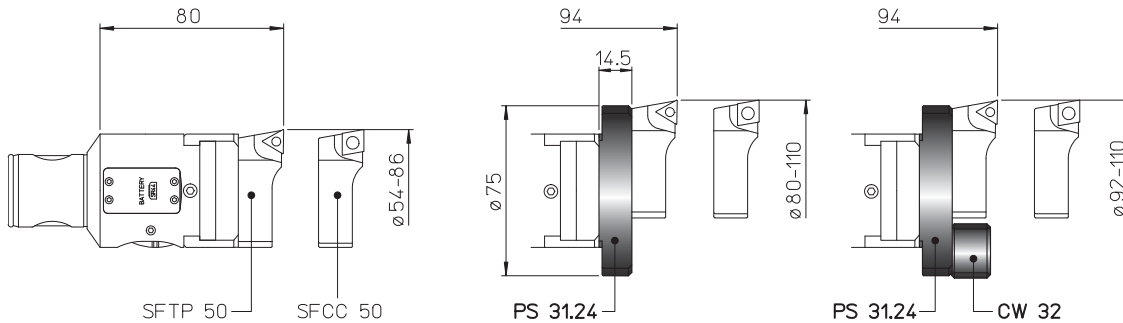
B8.06	572010506108	6 ~ 8	45	-	WCGT 0201..	-	TS 21	TORX T06	0.065
B8.08	572010508108	8 ~ 10	60				TS 211		0.08
B8.10	572010510108	10 ~ 12	75	-	TPGX 0902..	CS 250 T	TORX T08	0.1	
B8.12	572010512108	12 ~ 14	90					0.2	
B8.14	572010514108	14 ~ 16	105					0.3	
B8.16	572010516108	16 ~ 18	120					0.3	



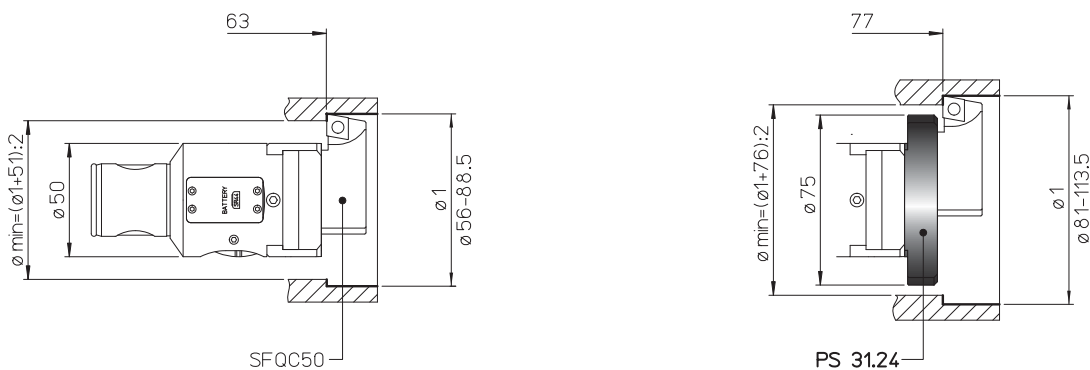
#### MHD'50

- TOOLHOLDERS FOR TESTAROSSA
- WERKZEUGE FÜR TESTAROSSA
- PORTAHERRAMIENTAS PARA TESTAROSSA
- PORTE-OUTILS POUR TESTAROSSA
- PORTAUTENSILI PER TESTAROSSA

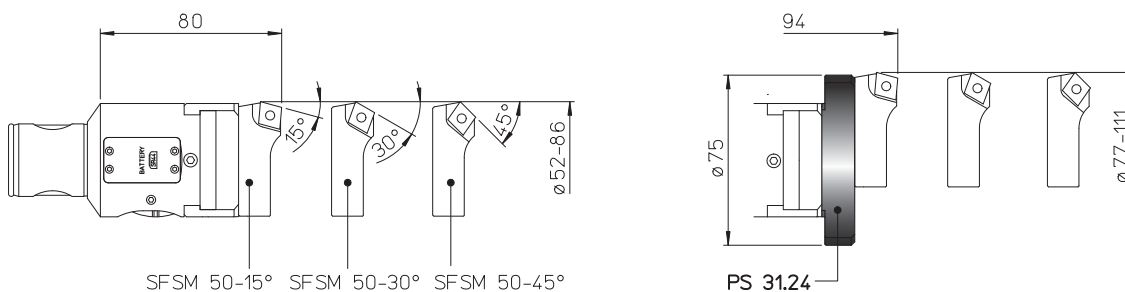
**PS 31**  
**CW 32**  
Ø 54 ~ 110



**PS 31**  
Ø 56 ~ 113.5



**PS 31**  
Ø 52 ~ 111

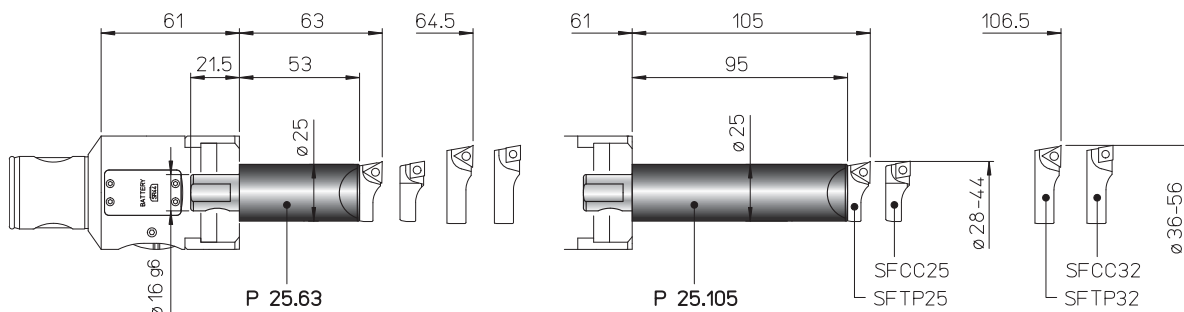


REF.	CODE	Kg.
PS 31.24 TR..50	433024140751	0.19
CW 32	392011003201	0.07



- TOOLHOLDERS FOR TESTAROSSA
- WERKZEUGE FÜR TESTAROSSA
- PORTAHERRAMIENTAS PARA TESTAROSSA
- PORTE-OUTILS POUR TESTAROSSA
- PORTAUTENSILI PER TESTAROSSA

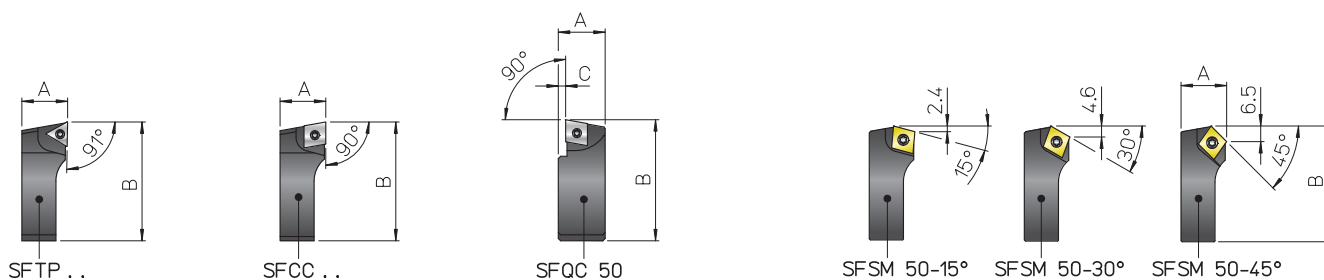
P 25  
Ø 28 ~ 56



REF.	CODE	Kg.
P25.63 TR...	435116250631	0.5
P25.105 TR...	435116251051	0.8

- BIT-HOLDERS FOR TESTAROSSA
- PLATTENHALTER FÜR TESTAROSSA
- PORTA-PLAQUITAS PARA TESTAROSSA
- PORTE-PLAQUETTES POUR TESTAROSSA
- SEGGI PER TESTAROSSA

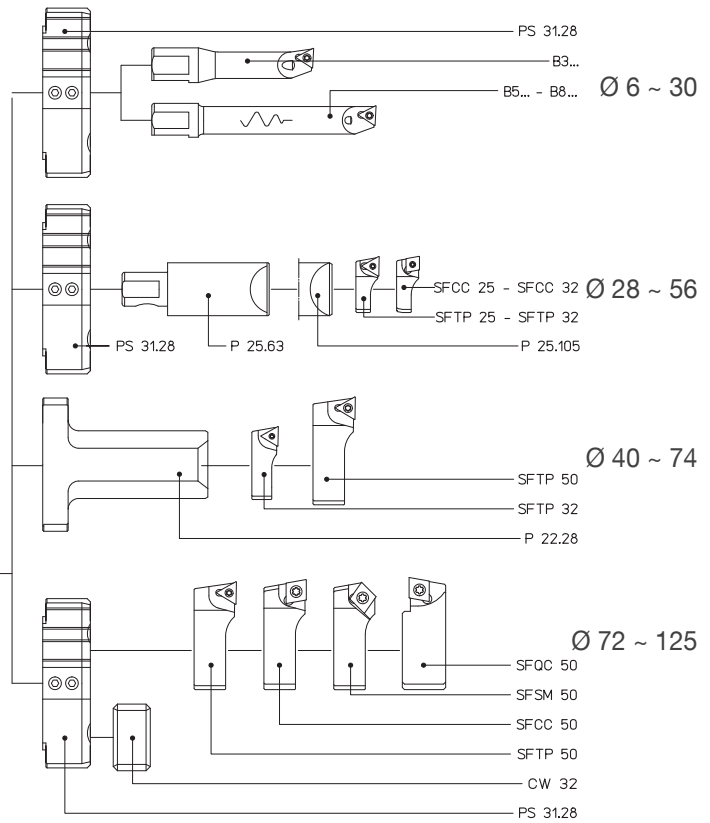
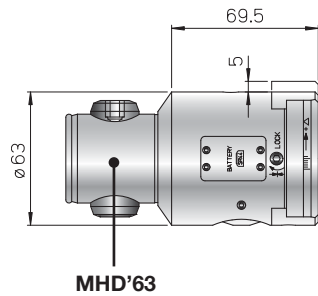
SF



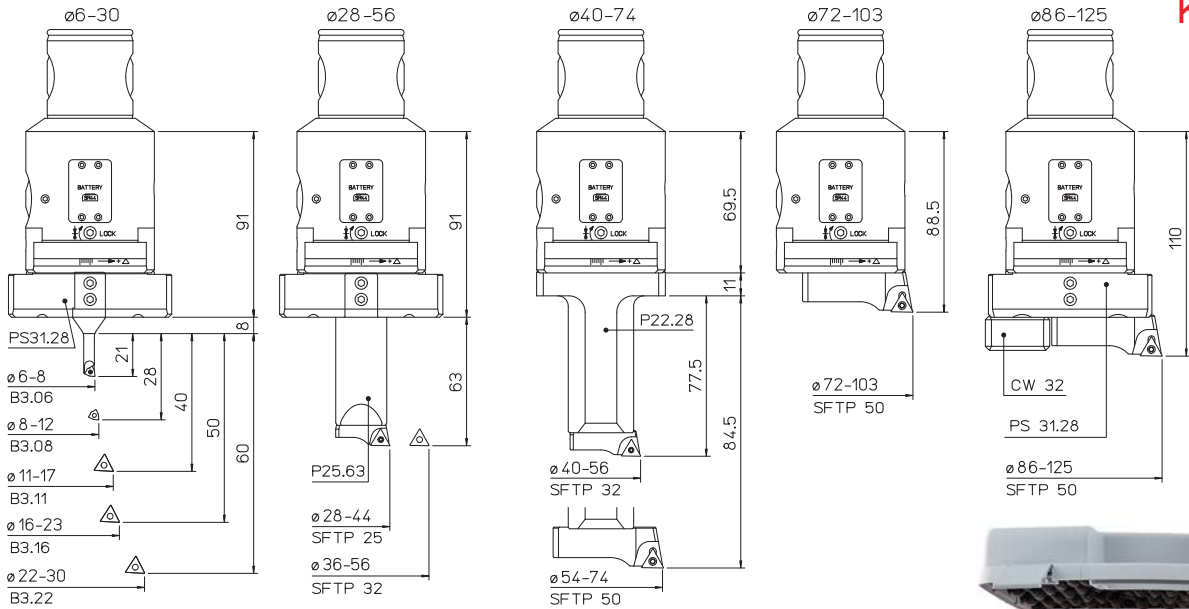
REF.	CODE	A	B	C	△	□	⌋	⌋	Kg.
SFTP 25	470500525001	10	26.5	-	TPGX 0902..	-	CS 250T	TORX T08	0.01
SFTP 32	470500532001	11.5	34.5	-	-	-	0.02		
SFTP 50	470500550001	19	52	-	TPGX 1103..	-	CS 300890T		0.08
SFCC 25	470500525002	10	26.5	-	-	CCGT 0602..	TS 25	TORX T08	0.01
SFCC 32	470500532002	11.5	34.5	-	-	-	-	TORX T08	0.02
SFCC 50	470500550002	19	52	-	-	CCGT 09T3..	TS 4	TORX T15	0.08
SFQC 50	470500550062	20.5	53	3	-	CCMT 09T3..	TS 4	TORXT15	0.1
SFSM 50-15°	470500550011	19	50.5	-	-	CCMT 09T3..	TS 4	TORXT15	0.07
SFSM 50-30°	470500550013								
SFSM 50-45°	470500550015								



2 µm



REF.	CODE	Kg.
TR-ELETTRA 63 MHD'63	455200630630	2.2



**KIT K01**  
Ø 6 ~ 125



- 1 TR-ELETTRA 63 MHD'63
- 1 P25.63 1 B3.06 1 B3.22 5 TPGX 090202L DC100
- 1 P22.28 1 B3.08 1 SFTP25 1 TPGX 110302L DC100
- 1 PS 31.28 1 B3.11 1 SFTP32 2 WCGT 020102L DC100
- 1 CW 32 1 B3.16 1 SFTP50

REF.	CODE	Ø
KIT K01 TR-ELETTRA 63 MHD'63	655200500630	6 ~ 125

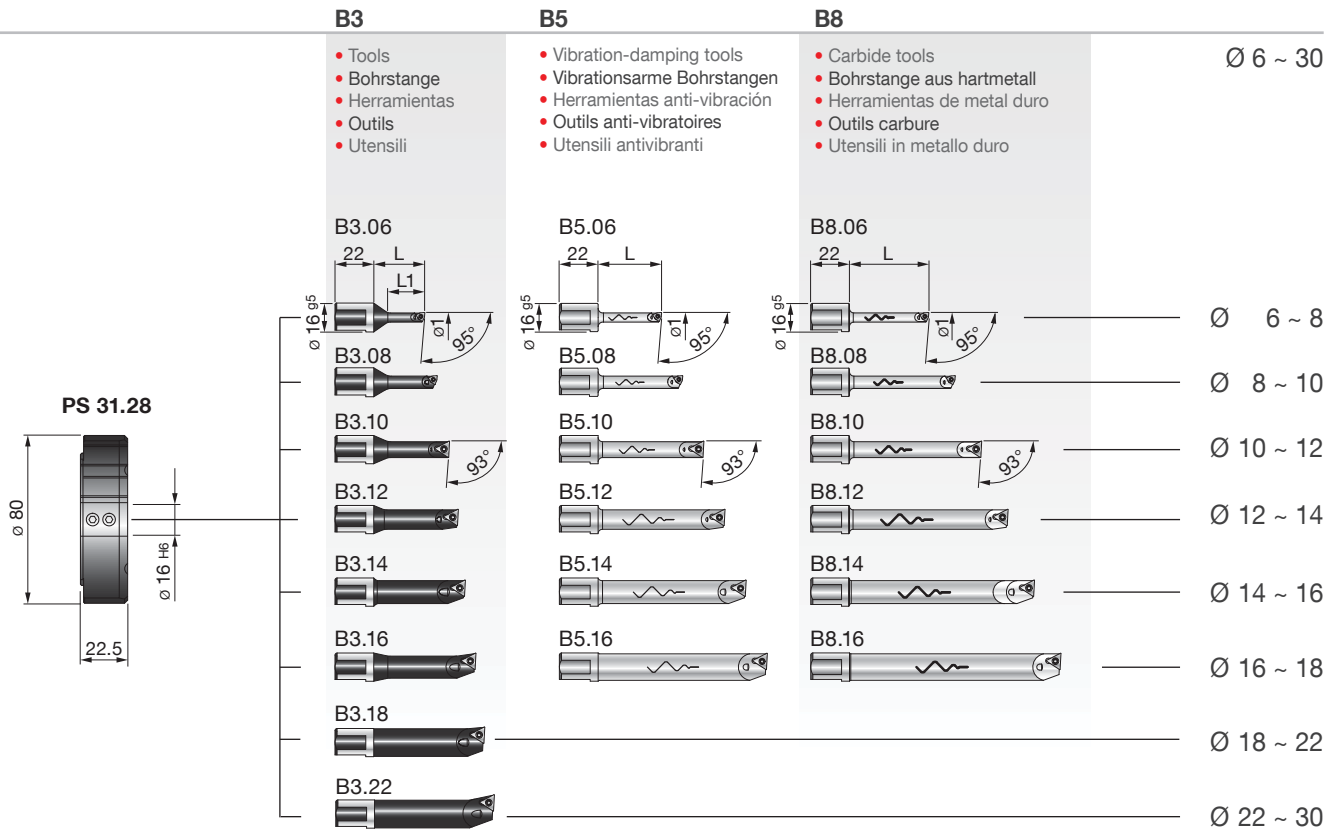
119 INFO

120 TOOLS

116 ELECTRICAL

241 PCB





REF.	CODE	Kg.
PS 31.28 TR-ELETTRA 63	433028220802	0.3

REF.	CODE	Ø1	L	L1	⚠	⚠	🔩	🔩	Kg.
B3.06	57 201 05 06 001	6 ~ 8	29	21	WCGT 0201..	-	TS 21	TORX T06	0.035
B3.08	57 201 05 08 001	8 ~ 10	36	28			TS 211		0.04
B3.10	57 201 05 10 001	10 ~ 12	43	35					0.05
B3.11	57 201 05 11 001	11 ~ 13	48	40				0.055	
B3.12	57 201 05 12 001	12 ~ 14	48	42				0.06	
B3.14	57 201 05 14 001	14 ~ 16	52	50	-	TPGX 0902..	CS 250 T	TORX T08	0.07
B3.16	57 201 05 16 001	16 ~ 18	58						
B3.18	57 201 05 18 001	18 ~ 22	63	-					0.1
B3.22	57 201 05 22 001	22 ~ 30	68	-					

B5.06	57 201 05 06 105	6 ~ 8	36	-	WCGT 0201..	-	TS 21	TORX T06	0.075
B5.08	57 201 05 08 105	8 ~ 10	48				TS 211		0.09
B5.10	57 201 05 10 105	10 ~ 12	60						
B5.12	57 201 05 12 105	12 ~ 14	72		-	TPGX 0902..	CS 250 T	TORX T08	0.2
B5.14	57 201 05 14 105	14 ~ 16	84						0.3
B5.16	57 201 05 16 105	16 ~ 18	96						

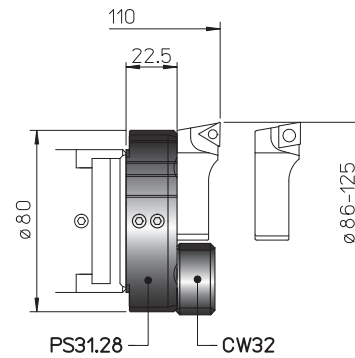
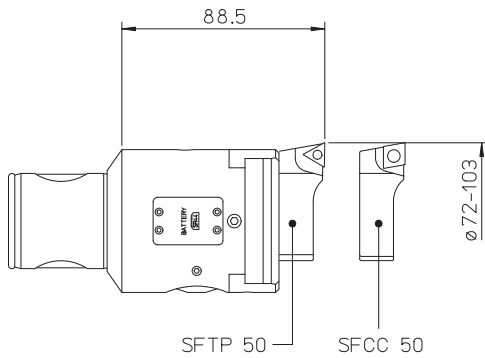
B8.06	57 201 05 06 108	6 ~ 8	45	-	WCGT 0201..	-	TS 21	TORX T06	0.065
B8.08	57 201 05 08 108	8 ~ 10	60				TS 211		0.08
B8.10	57 201 05 10 108	10 ~ 12	75						
B8.12	57 201 05 12 108	12 ~ 14	90		-	TPGX 0902..	CS 250 T	TORX T08	0.2
B8.14	57 201 05 14 108	14 ~ 16	105						0.3
B8.16	57 201 05 16 108	16 ~ 18	120						



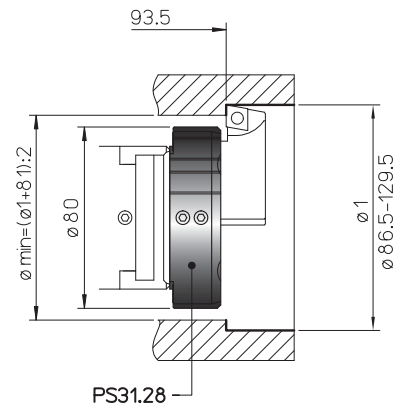
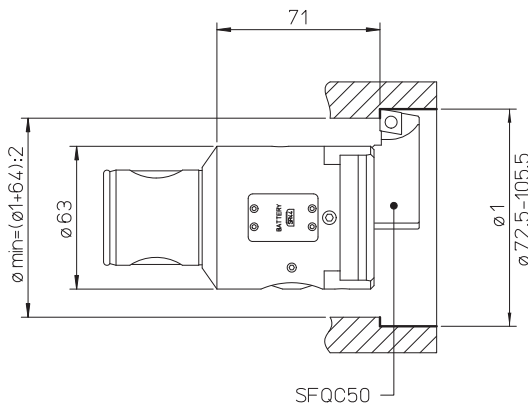
#### MHD'63

- TOOLHOLDERS FOR TESTAROSSA
- WERKZEUGE FÜR TESTAROSSA
- PORTAHERRAMIENTAS PARA TESTAROSSA
- PORTE-OUTILS POUR TESTAROSSA
- PORTAUTENSILI PER TESTAROSSA

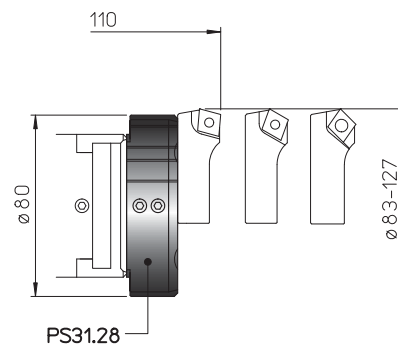
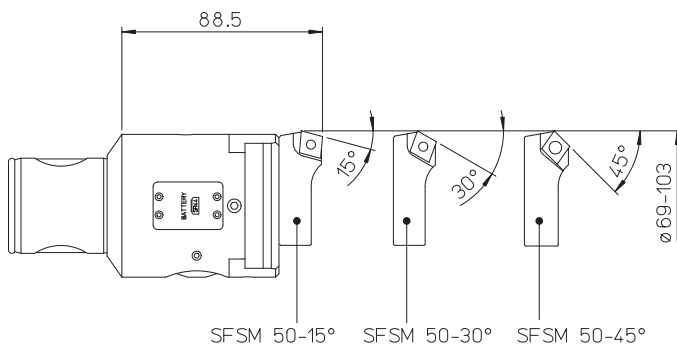
**PS 31**  
**CW 32**  
Ø 72~125



**PS 31**  
Ø 72.5 ~ 129.5



**PS 31**  
Ø 69 ~ 127



REF.	CODE	Kg.
PS 31.28 TR-ELETTRA 63	433028220802	0.3
CW 32	392011003201	0.07

119



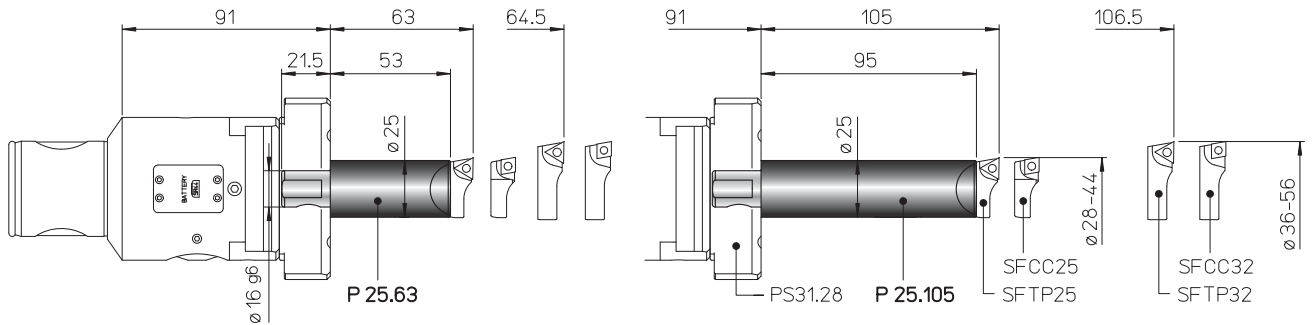
125





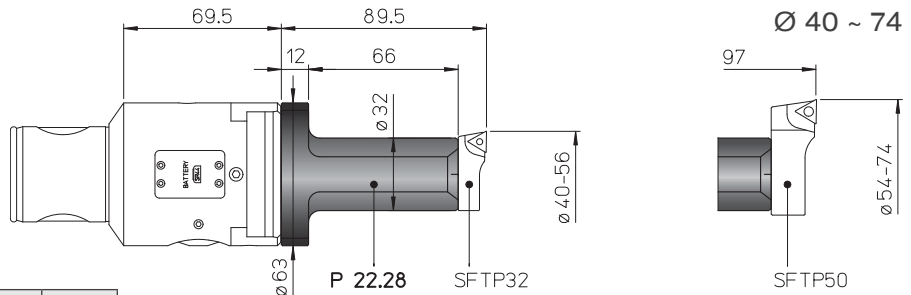
- TOOLHOLDERS FOR TESTAROSSA
- WERKZEUGE FÜR TESTAROSSA
- PORTAHERRAMIENTAS PARA TESTAROSSA
- PORTE-OUTILS POUR TESTAROSSA
- PORTAUTENSILI PER TESTAROSSA

P 25  
Ø 28 ~ 56



REF.	CODE	Kg.
P25.63 TR...	435116250631	0.5
P25.105 TR...	435116251051	0.8

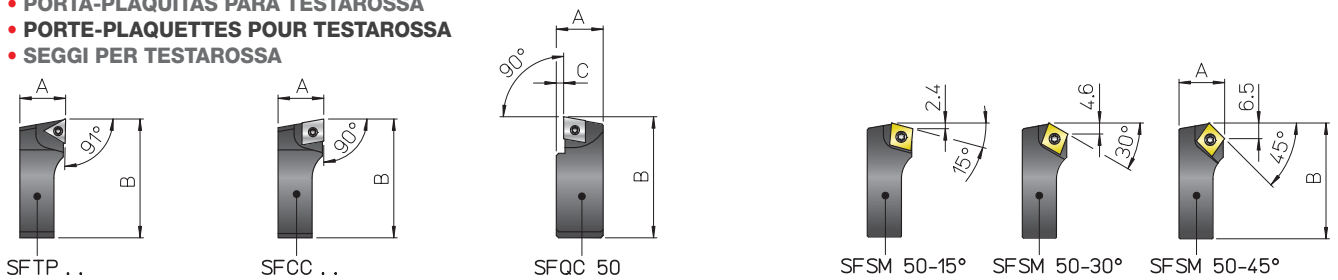
P 22  
Ø 40 ~ 74



REF.	CODE	Kg.
P 22.28	433028220631	0.45

- BIT-HOLDERS FOR TESTAROSSA
- PLATTENHALTER FÜR TESTAROSSA
- PORTA-PLAQUITAS PARA TESTAROSSA
- PORTE-PLAQUETTES POUR TESTAROSSA
- SEGGI PER TESTAROSSA

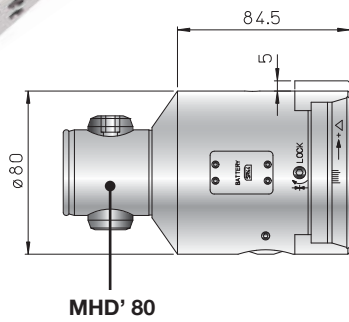
SF



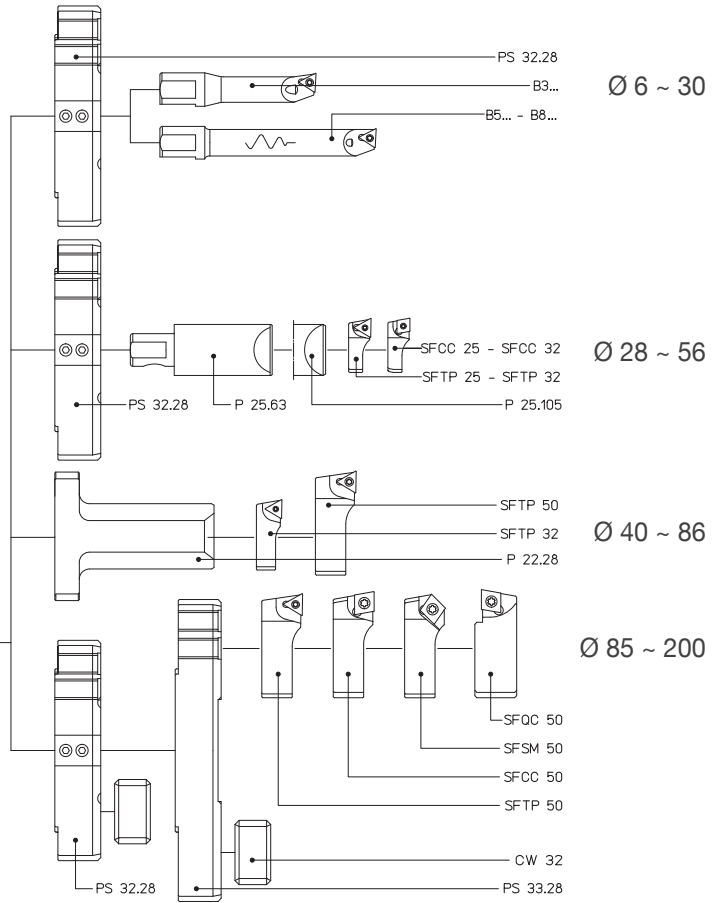
REF.	CODE	A	B	C	⚠	⊞	⊞	⊞	Kg.
SFTP 25	470500525001	10	26.5	-	TPGX 0902..	-	CS 250T	TORX T08	0.01
SFTP 32	470500532001	11.5	34.5	-	-	-	CS 300890T	TORX T08	0.02
SFTP 50	470500550001	19	52	-	TPGX 1103..	-	CS 300890T	TORX T15	0.08
SFCC 25	470500525002	10	26.5	-	-	CCGT 0602..	TS 25	TORX T08	0.01
SFCC 32	470500532002	11.5	34.5	-	-	CCGT 09T3..	TS 4	TORX T15	0.02
SFCC 50	470500550002	19	52	-	-	CCGT 09T3..	TS 4	TORX T15	0.08
SFQC 50	470500550062	20.5	53	3	-	CCMT 09T3..	TS 4	TORXT15	0.1
SFSM 50-15°	470500550011	19	50.5	-	-	CCMT 09T3..	TS 4	TORXT15	0.07
SFSM 50-30°	470500550013								
SFSM 50-45°	470500550015								



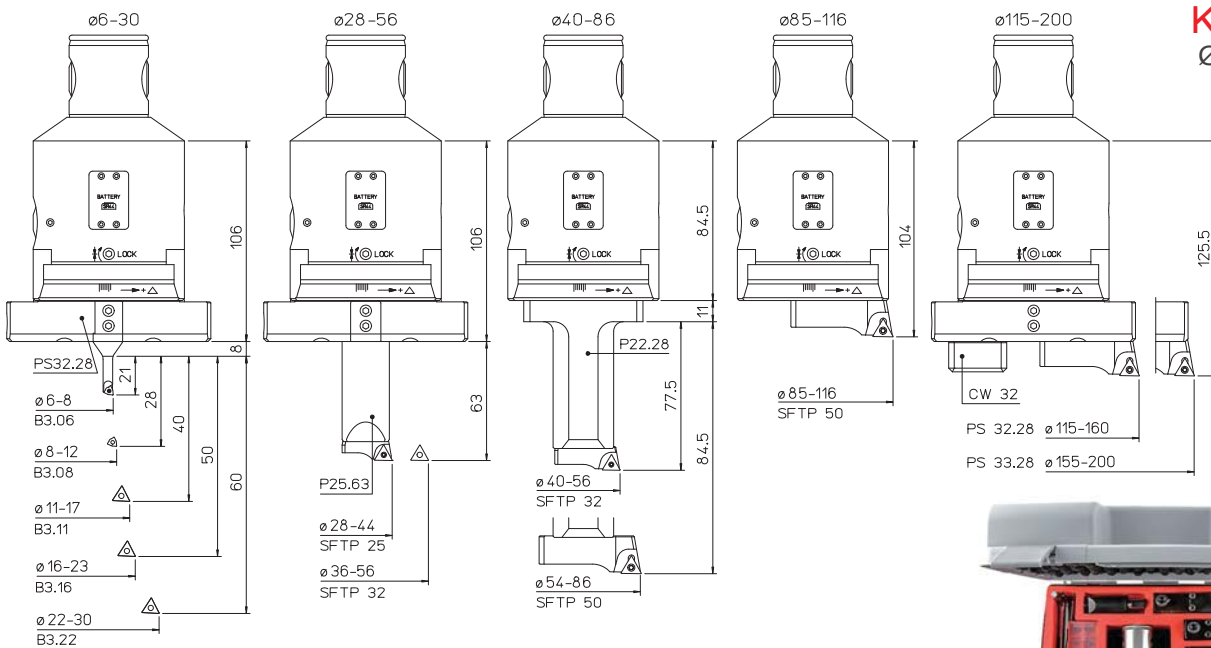
2 µm



MHD'80



REF.	CODE	Kg.
TR-ELETTRA 80 MHD'80	455200800800	3.9



**KIT K01**  
Ø 6 ~ 200

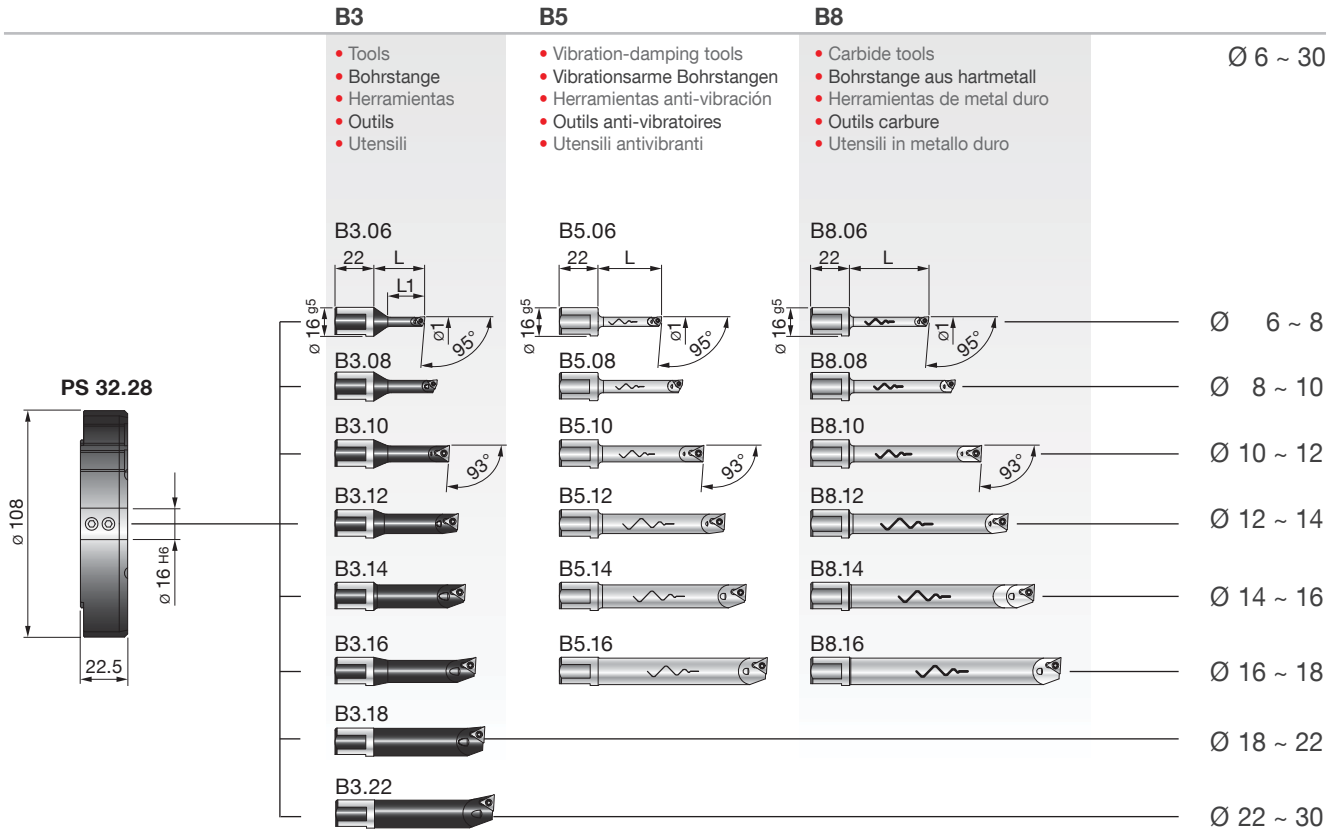
- 1 TR-ELETTRA 80 MHD'80
- 1 P25.63 1 CW 32 1 B3.16 1 SFTP50
- 1 P22.28 1 B3.06 1 B3.22 5 TPGX 090202L DC100
- 1 PS 32.28 1 B3.08 1 SFTP25 1 TPGX 110302L DC100
- 1 PS 33.28 1 B3.11 1 SFTP32 2 WCGT 020102L DC100



REF.	CODE	Ø
K01 TR-ELETTRA 80 MHD'80	655200500800	6 ~ 200

119 120 116 241





REF.	CODE	Kg.
PS 32.28 TR-ELETTRA 80	433028221082	0.5

REF.	CODE	Ø1	L	L1	⚠	⚠	🔩	🔩	Kg.
B3.06	572010506001	6 ~ 8	29	21	WCGT 0201..	-	TS 21	TORX T06	0.035
B3.08	572010508001	8 ~ 10	36	28			TS 211		0.04
B3.10	572010510001	10 ~ 12	43	35	-	TPGX 0902..	CS 250 T	TORX T08	0.05
B3.11	572010511001	11 ~ 13	48	40					0.055
B3.12	572010512001	12 ~ 14	48	42					0.06
B3.14	572010514001	14 ~ 16	52	50	-	TPGX 0902..	CS 250 T	TORX T08	0.07
B3.16	572010516001	16 ~ 18	58	50					0.07
B3.18	572010518001	18 ~ 22	63	-	-	TPGX 0902..	CS 250 T	TORX T08	0.1
B3.22	572010522001	22 ~ 30	68	-					0.1
B5.06	572010506105	6 ~ 8	36	-	WCGT 0201..	-	TS 21	TORX T06	0.075
B5.08	572010508105	8 ~ 10	48						0.09
B5.10	572010510105	10 ~ 12	60	-	-	TPGX 0902..	CS 250 T	TORX T08	0.1
B5.12	572010512105	12 ~ 14	72						0.2
B5.14	572010514105	14 ~ 16	84						0.3
B5.16	572010516105	16 ~ 18	96	-	-	TPGX 0902..	CS 250 T	TORX T08	0.3
B8.06	572010506108	6 ~ 8	45	0.065					
B8.08	572010508108	8 ~ 10	60	WCGT 0201..	-	TS 21	TORX T06	0.08	
B8.10	572010510108	10 ~ 12	75					0.1	
B8.12	572010512108	12 ~ 14	90	-	TPGX 0902..	CS 250 T	TORX T08	0.2	
B8.14	572010514108	14 ~ 16	105					0.3	
B8.16	572010516108	16 ~ 18	120					0.3	



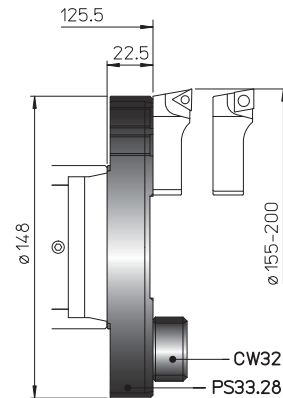
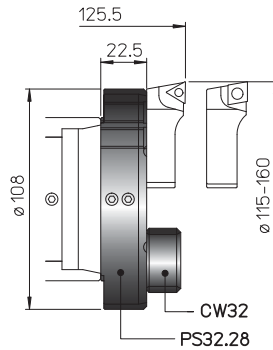
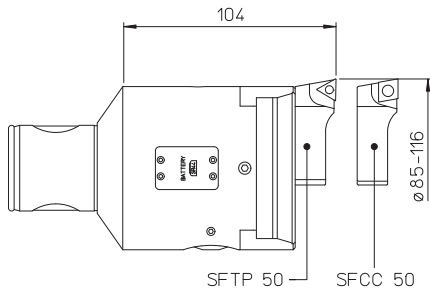
#### MHD'80

- TOOLHOLDERS FOR TESTAROSSA
- WERKZEUGE FÜR TESTAROSSA
- PORTAHERRAMIENTAS PARA TESTAROSSA
- PORTE-OUTILS POUR TESTAROSSA
- PORTAUTENSILI PER TESTAROSSA

PS

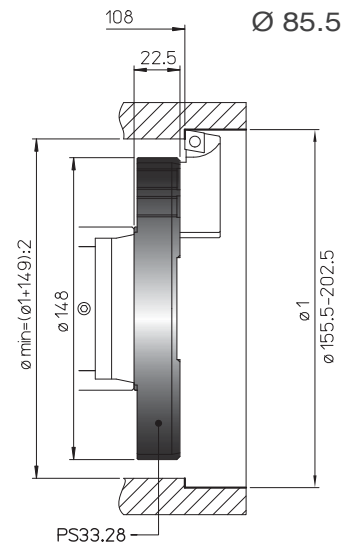
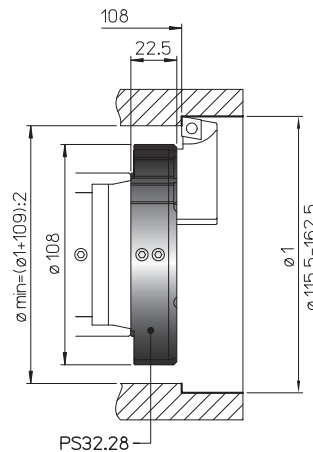
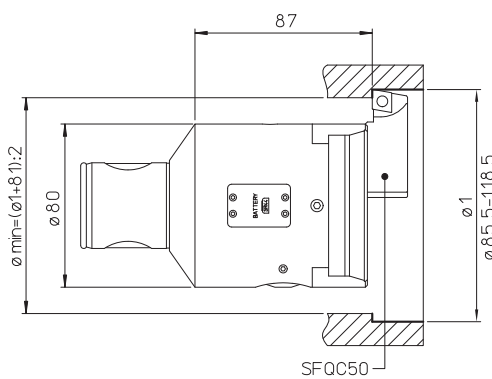
CW 32

Ø 85~ 200



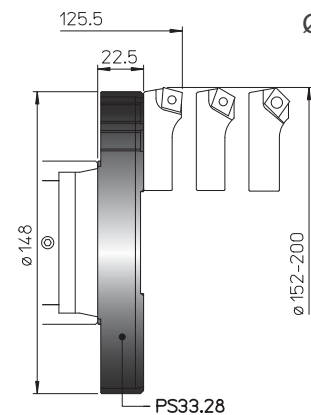
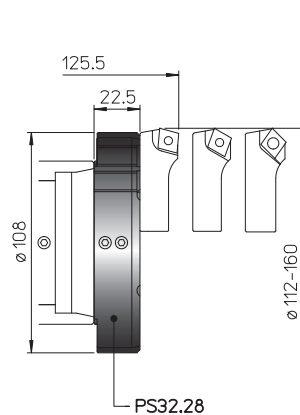
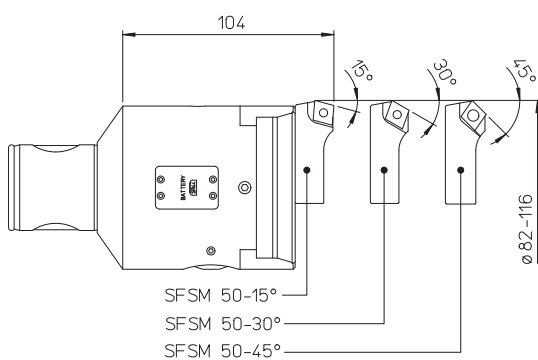
PS

Ø 85.5 ~ 202.5



PS

Ø 82 ~ 200



REF.	CODE	Kg.
PS 32.28 TR-ELETTRA 80	433028221082	0.5
PS 33.28 TR-ELETTRA 80	433028221482	0.6
CW 32	392011003201	0.07

119

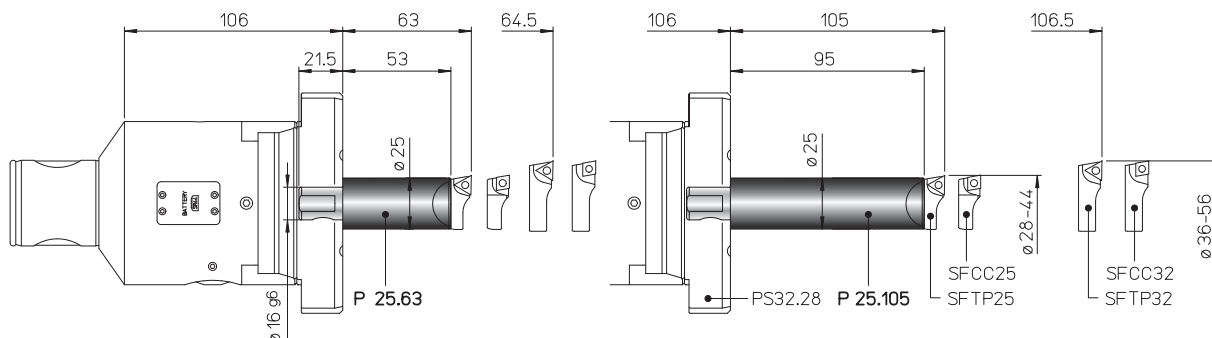


125



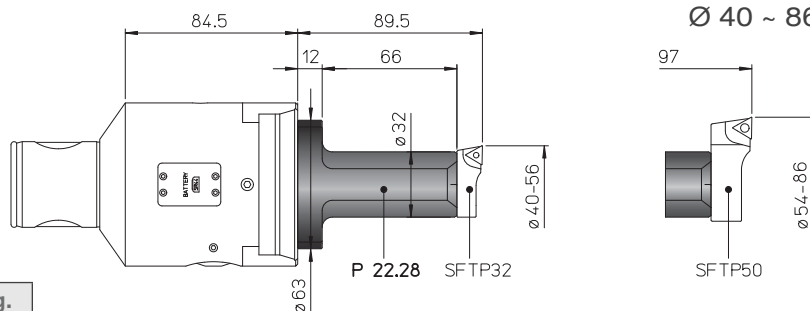
- TOOLHOLDERS FOR TESTAROSSA
- WERKZEUGE FÜR TESTAROSSA
- PORTAHERRAMIENTAS PARA TESTAROSSA
- PORTE-OUTILS POUR TESTAROSSA
- PORTAUTENSILI PER TESTAROSSA

P 25  
Ø 28 ~ 56



REF.	CODE	Kg.
P25.63 TR...	435116250631	0.5
P25.105 TR...	435116251051	0.8

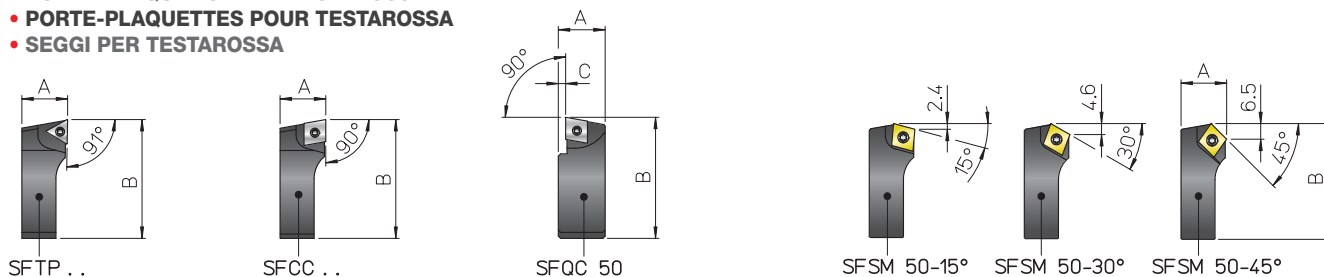
P 22  
Ø 40 ~ 86



REF.	CODE	Kg.
P 22.28	433028220631	0.45

- BIT-HOLDERS FOR TESTAROSSA
- PLATTENHALTER FÜR TESTAROSSA
- PORTA-PLAQUITAS PARA TESTAROSSA
- PORTE-PLAQUETTES POUR TESTAROSSA
- SEGGI PER TESTAROSSA

SF



REF.	CODE	A	B	C	⚠	⊞	⚙	🔧	Kg.
SFTP 25	470500525001	10	26.5	-	TPGX 0902..	-	CS 250T	TORX T08	0.01
SFTP 32	470500532001	11.5	34.5	-	-	-	CS 300890T	TORX T08	0.02
SFTP 50	470500550001	19	52	-	TPGX 1103..	-	CS 300890T	TORX T15	0.08
SFCC 25	470500525002	10	26.5	-	-	CCGT 0602..	TS 25	TORX T08	0.01
SFCC 32	470500532002	11.5	34.5	-	-	CCGT 09T3..	TS 4	TORX T08	0.02
SFCC 50	470500550002	19	52	-	-	CCGT 09T3..	TS 4	TORX T15	0.08
SFQC 50	470500550062	20.5	53	3	-	CCMT 09T3..	TS 4	TORXT15	0.1
SFSM 50-15°	470500550011	19	50.5	-	-	CCMT 09T3..	TS 4	TORXT15	0.07
SFSM 50-30°	470500550013								
SFSM 50-45°	470500550015								

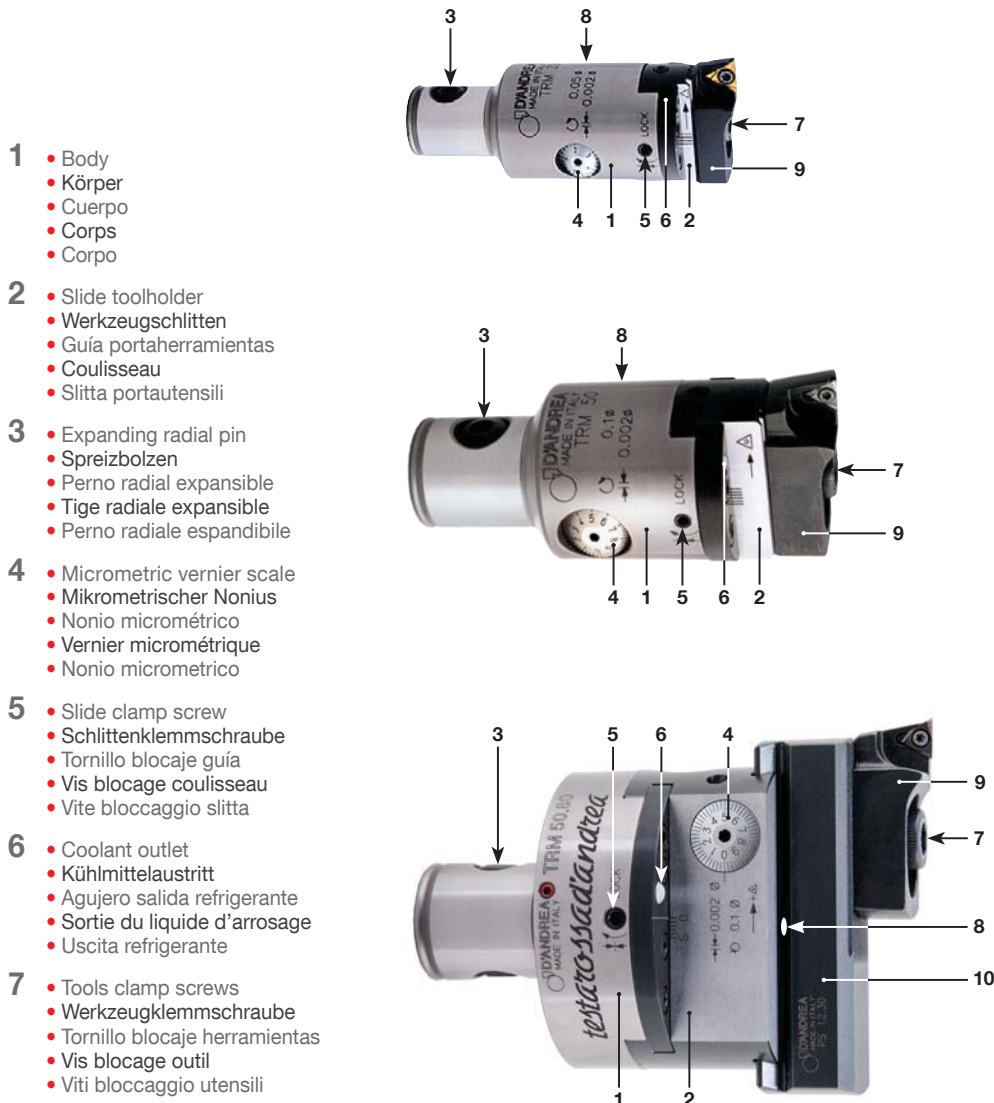
116

125

119







- 1 • Body  
• Körper  
• Cuerpo  
• Corps  
• Corpo
- 2 • Slide toolholder  
• Werkzeugschlitten  
• Guía portaherramientas  
• Coulisseau  
• Slitta portautensili
- 3 • Expanding radial pin  
• Spreizbolzen  
• Perno radial expansible  
• Tige radiale expansible  
• Perno radiale espandibile
- 4 • Micrometric vernier scale  
• Mikrometrischer Nonius  
• Nonio micrométrico  
• Vernier micrométrique  
• Nonio micrometrico
- 5 • Slide clamp screw  
• Schlittenklemmschraube  
• Tornillo bloqueo guía  
• Vis blocage coulisseau  
• Vite bloccaggio slitta
- 6 • Coolant outlet  
• Kühlmittelaustritt  
• Agujero salida refrigerante  
• Sortie du liquide d'arrosage  
• Uscita refrigerante
- 7 • Tools clamp screws  
• Werkzeugklemmschraube  
• Tornillo bloqueo herramientas  
• Vis blocage outil  
• Viti bloccaggio utensili

## 2 μm



- 8 • Oiler  
• Schmiernippel  
• Engrasador  
• Graisseur  
• Oliatore
- 9 • Bit holder  
• Plattenhalter  
• Portaplaquita  
• Porte-plaquettes  
• Seggio portainserti
- 10 • Tool holder  
• Werkzeughalter  
• Portaherramienta  
• Porte-outil  
• Porta utensile

**GB FEATURES.** The TRM heads in the D'Andrea Testarossa line have protective rustproof coating. High precision work to IT6 tolerance, with excellent surface finish, is achieved using TRM boring heads. These are very sensitive and radial correction of 1 micron can be effected directly on the machine and easily read on the vernier scale.

**D MERKMALE.** Die TRM Köpfe der Testarossa-Serie besitzen eine rostbeständige Oberfläche. Die TRM-Köpfe ermöglichen ermöglichen Bearbeitungen mit hoher Präzision und Toleranzen mit Grad IT6 bei hochwertiger Oberflächengüte. Sie besitzen eine Feinverstellung mit einer Genauigkeit von radial 1 μm, wobei das Maß auf der Skala abgelesen und auch direkt an der Maschine eingestellt werden kann.

**E CARACTERÍSTICAS.** Los cabezales TRM de la línea Testarossa D'Andrea cuentan con una protección superficial anticorrosión. Los cabezales TRM permiten realizar operaciones de alta precisión con tolerancias de grado IT6 con un extraordinario acabado de la superficie. Tienen una sensibilidad de ajuste de 1 micra en radio, de fácil lectura en el nonio y corregibles directamente sobre la máquina.

**F CARACTÉRISTIQUES.** Les têtes TRM de la ligne Testarossa D'Andrea ont une protection superficielle anticorrosion. Les têtes TRM permettent des usinages de haute précision avec des tolérances de degré IT6 pour un excellent finissage superficiel. Elles ont une sensibilité de réglage de 1 micron sur le rayon, facilement lisible sur le vernier et exécutable également dans la machine.

**I CARATTERISTICHE.** Le testine TRM della linea Testarossa D'Andrea hanno una protezione superficiale anticorrosiva. Le testine TRM consentono lavorazioni di alta precisione con tolleranze di grado IT6 con ottima finitura superficiale. Hanno una sensibilità di regolazione di 1 micron sul raggio, facilmente leggibile sul nonio ed eseguibile anche in macchina.



**TRM 16**

Ø 18 ~ 23



**TRM 20**

Ø 22 ~ 29



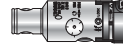
**TRM 25**

Ø 28 ~ 38



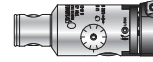
**TRM 32**

Ø 35.5 ~ 51.5



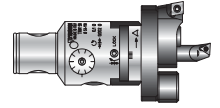
**TRM 40**

Ø 48 ~ 63



**TRM 50**

Ø 2.5 ~ 108



**TRM 50/63**

Ø 6 ~ 125



**TRM 63/63**

Ø 6 ~ 125



**TRM 50/80**

Ø 6 ~ 160



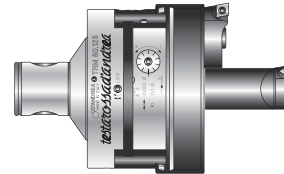
**TRM 80/80**

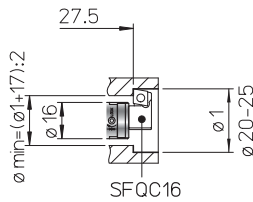
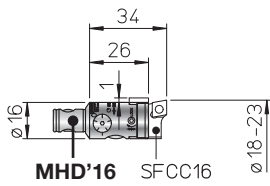
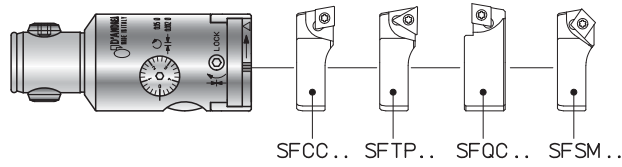
Ø 6 ~ 160



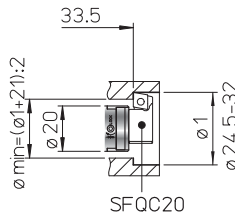
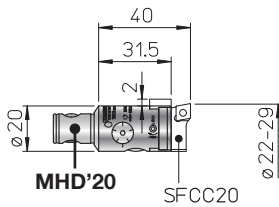
**TRM 80/125**

Ø 36 ~ 500

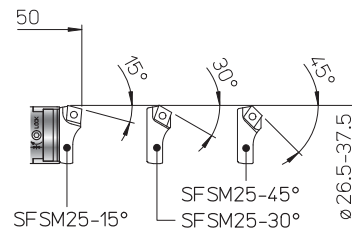
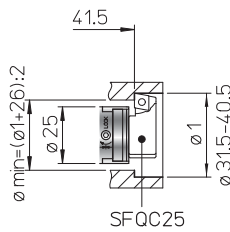
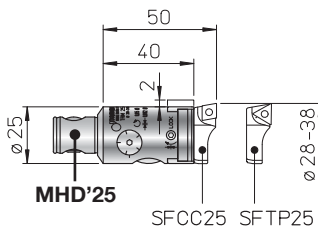




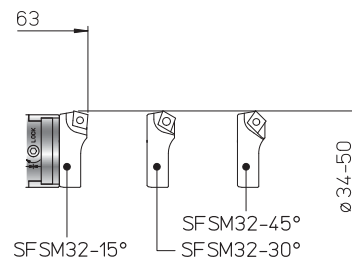
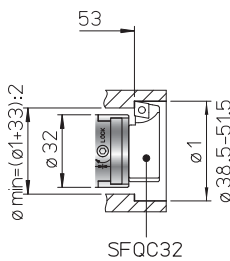
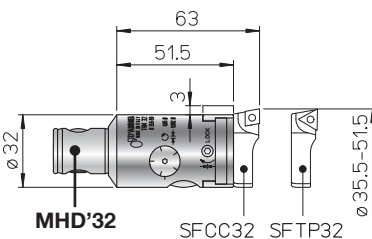
**TRM 16**  
Ø 18 ~ 23



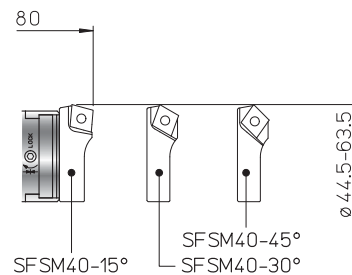
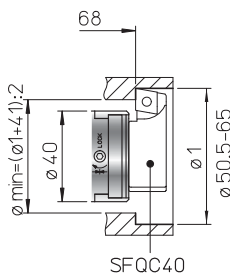
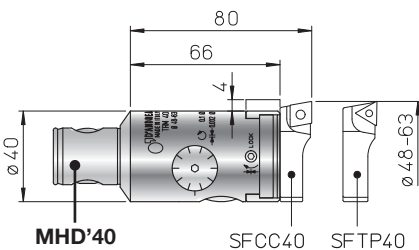
**TRM 20**  
Ø 22 ~ 29



**TRM 25**  
Ø 28 ~ 38



**TRM 32**  
Ø 35.5 ~ 51.5



**TRM 40**  
Ø 48 ~ 63



TRM

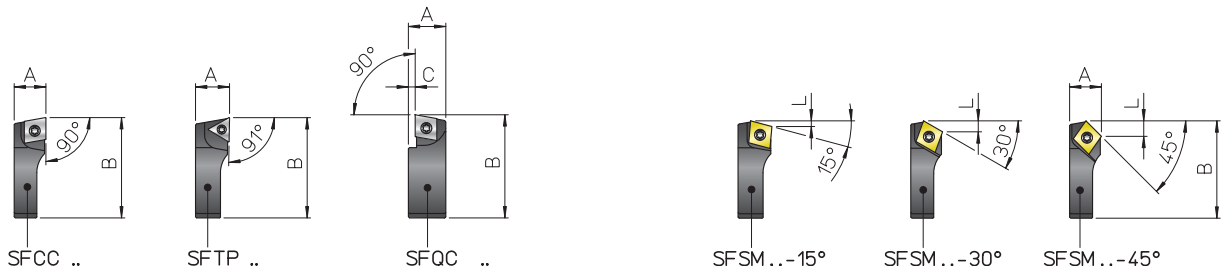


2 µm

REF.	CODE	Kg.
TRM 16	455001600341	0.05
TRM 20	455002000401	0.1
TRM 25	455002500500	0.2
TRM 32	455003200630	0.35
TRM 40	455004000800	0.7

- BIT-HOLDERS FOR TESTAROSSA
- PLATTENHALTER FÜR TESTAROSSA
- PORTA-PLAQUITAS PARA TESTAROSSA
- PORTE-PLAQUETTES POUR TESTAROSSA
- SEGGI PER TESTAROSSA

SF



REF.	CODE	A	B	C	L	□	△	⌊	⌋	Kg.
SFCC 16	470500516002	8	17							0.003
SFCC 20	470500520002	8.5	21							0.005
SFCC 25	470500525002	10	26.5	-	-	CCGT 0602..	-	TS 25	TORX T08	0.01
SFCC 32	470500532002	11.5	34.5							0.02
SFCC 40	470500540002	14	44	-	-	CCGT 09T3..	-	TS 4	TORX T15	0.04
SFTP 25	470500525001	10	26.5	-	-	-	TPGX 0902..	CS 250T	TORX T08	0.01
SFTP 32	470500532001	11.5	34.5							0.02
SFTP 40	470500540001	14	44	-	-	-	TPGX 1103..	CS 300890T		0.04
SFQC 16	470500516062	10	18	2						0.005
SFQC 20	470500520062	10.5	22.5							0.008
SFQC 25	470500525062	12	28.5	2.5		CCMT 0602..	-	TS 25	TORX T08	0.01
SFQC 32	470500532062	13.5	35.5							0.03
SFQC 40	470500540062	16.5	46	3		CCMT 09T3..	-	TS 4	TORXT15	0.06
SFSM 25-15°	470500525011				1.6					
SFSM 25-30°	470500525013	10	25.5	-	3					0.01
SFSM 25-45°	470500525015				4.3					
SFSM 32-15°	470500532011				1.6					
SFSM 32-30°	470500532013	11.5	33.5	-	3	CCMT 0602..	-	TS 25	TORX T08	0.02
SFSM 32-45°	470500532015				4.3					
SFSM 40-15°	470500540011				2.4					
SFSM 40-30°	470500540013	14	42.5	-	4.6	CCMT 09T3..	-	TS 4	TORXT15	0.03
SFSM 40-45°	470500540015				6.6					





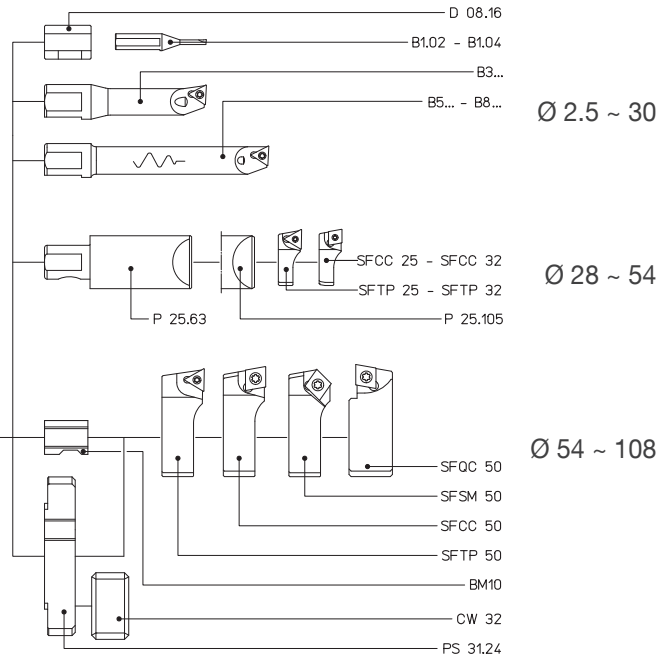
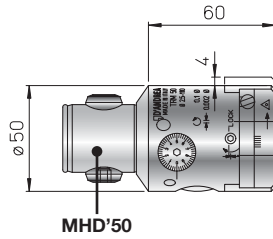
# D'ANDREA MODULHARD'ANDREA

**TRM 50** Ø 2.5 ~ 108

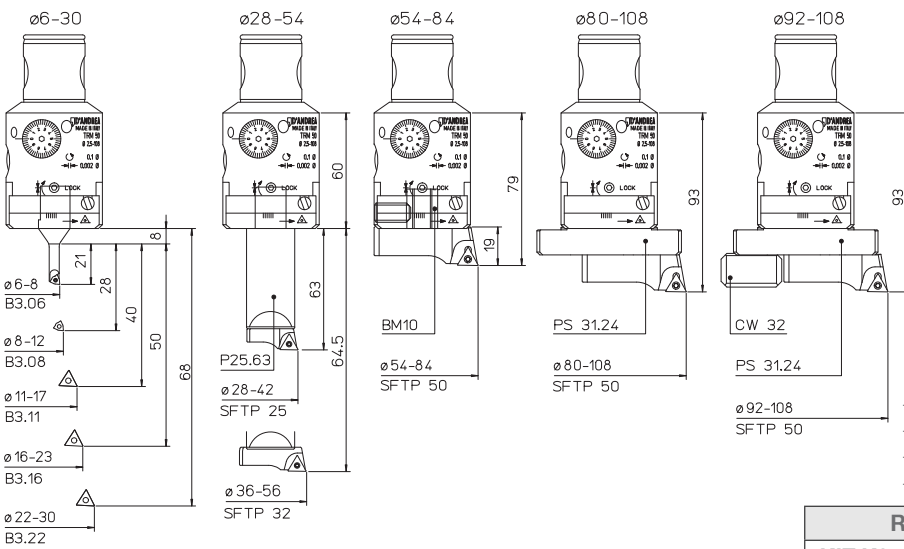
• TESTAROSSA



**2 μm**



REF.	CODE	Kg.
TRM 50	455005000500	1

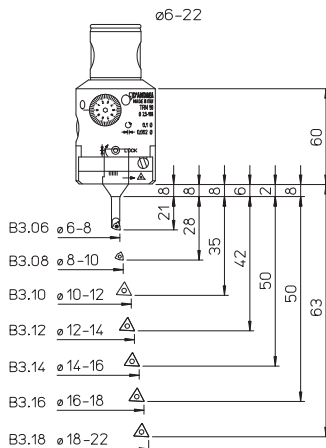


**KIT K01**  
Ø 6 ~ 108



- 1 TRM 50
- 1 CW 32
- 1 B3.16
- 1 SFTP50
- 1 P25.63
- 1 B3.06
- 1 B3.22
- 5 TPGX 090202L DC100
- 1 BM10
- 1 B3.08
- 1 SFTP25
- 1 TPGX 110302L DC100
- 1 PS 31.24
- 1 B3.11
- 1 SFTP32
- 2 WCGT 020102L DC100

REF.	CODE	Ø
KIT K01 TRM 50	655005010501	6 ~ 108



**KIT K00**  
Ø 6 ~ 22



- 1 TRM50
- 1 B3.10
- 1 B3.16
- 5 TPGX 090202L DC100
- 1 B3.06
- 1 B3.12
- 1 B3.18
- 2 WCGT 020102L DC100
- 1 B3.08
- 1 B3.14

REF.	CODE	Ø
KIT K00 TRM 50	655005010500	6 ~ 22

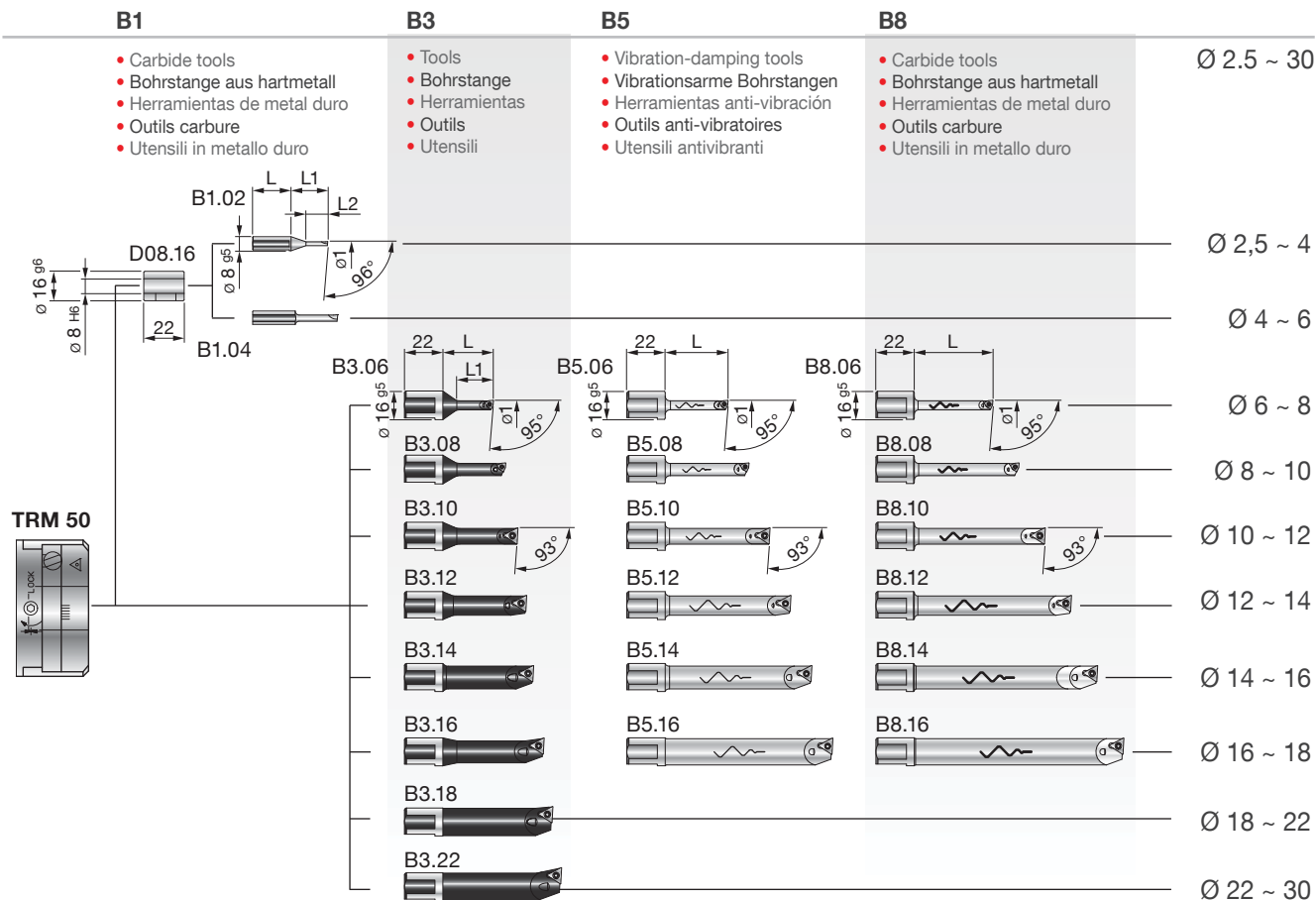
119 INFO

120

116

241





REF.	CODE	Kg.
D08.16	200560116082	0.02

REF.	CODE	Ø1	L	L1	L2	Kg.
B1.02	572010502001	2.5 ~ 4	22	21	12.5	0.02
B1.04	572010504001	4 ~ 6	24	24	-	

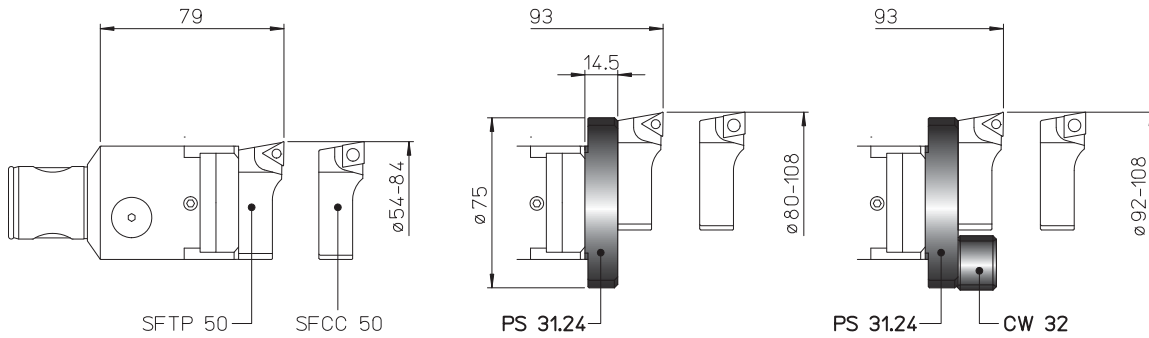
REF.	CODE	Ø1	L	L1	⊖	⊖	⊖	⊖	Kg.
B3.06	572010506001	6 ~ 8	29	21	WCGT 0201..	-	TS 21	TORX T06	0.035
B3.08	572010508001	8 ~ 10	36	28					0.04
B3.10	572010510001	10 ~ 12	43	35	-	TPGX 0902..	CS 250 T	TORX T08	0.05
B3.11	572010511001	11 ~ 13	48	40					0.055
B3.12	572010512001	12 ~ 14	48	42					0.06
B3.14	572010514001	14 ~ 16	52	50					0.07
B3.16	572010516001	16 ~ 18	58	50					0.07
B3.18	572010518001	18 ~ 22	63	-					0.1
B3.22	572010522001	22 ~ 30	68	-					0.1

B5.06	572010506105	6 ~ 8	36	-	WCGT 0201..	-	TS 21	TORX T06	0.075
B5.08	572010508105	8 ~ 10	48	-					0.09
B5.10	572010510105	10 ~ 12	60	-	-	TPGX 0902..	CS 250 T	TORX T08	0.1
B5.12	572010512105	12 ~ 14	72	-					0.2
B5.14	572010514105	14 ~ 16	84	-					0.3
B5.16	572010516105	16 ~ 18	96	-					0.3

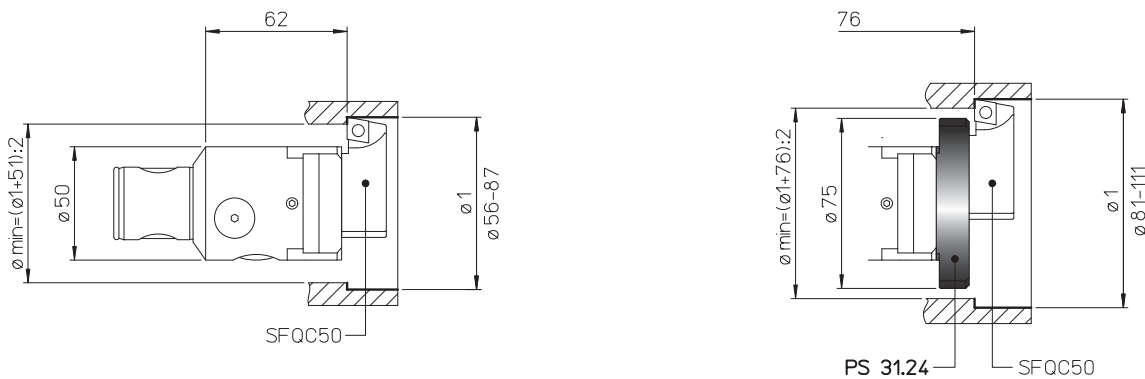
B8.06	572010506108	6 ~ 8	45	-	WCGT 0201..	-	TS 21	TORX T06	0.065
B8.08	572010508108	8 ~ 10	60	-					0.08
B8.10	572010510108	10 ~ 12	75	-	-	TPGX 0902..	CS 250 T	TORX T08	0.1
B8.12	572010512108	12 ~ 14	90	-					0.2
B8.14	572010514108	14 ~ 16	105	-					0.2
B8.16	572010516108	16 ~ 18	120	-					0.3

- TOOLHOLDERS FOR TESTAROSSA
- GRUNDHALTER FÜR TESTAROSSA
- PORTAHERRAMIENTAS PARA TESTAROSSA
- PORTE-OUTILS POUR TESTAROSSA
- PORTAUTENSILI PER TESTAROSSA

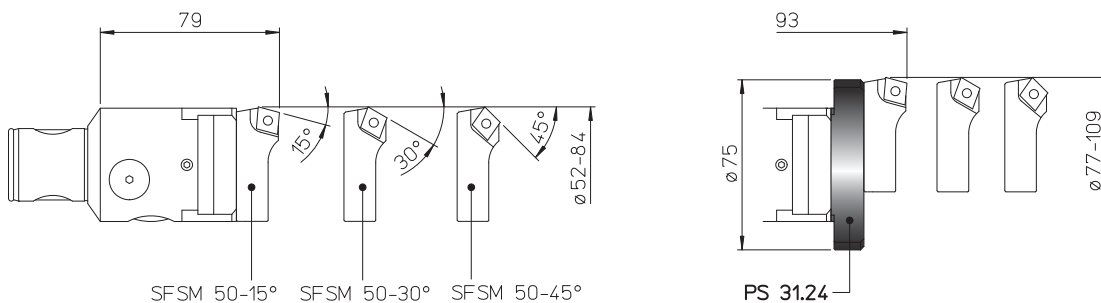
**PS 31**  
**CW 32**  
 $\varnothing$  54 ~ 108



**PS 31**  
 $\varnothing$  56 ~ 111



**PS 31**  
 $\varnothing$  52 ~ 109



REF.	CODE	Kg.
PS 31.24 TR..50	433024140751	0.19
CW 32	392011003201	0.07

119

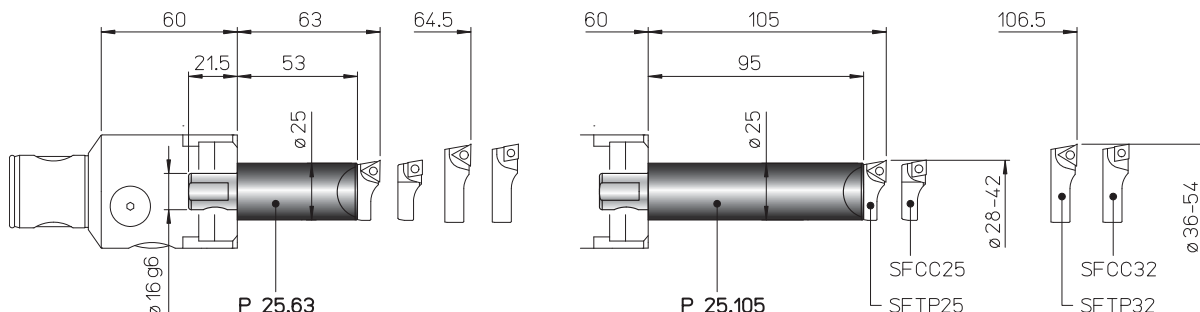


125



- TOOLHOLDERS FOR TESTAROSSA
- GRUNDHALTER FÜR TESTAROSSA
- PORTAHERRAMIENTAS PARA TESTAROSSA
- PORTE-OUTILS POUR TESTAROSSA
- PORTAUTENSILI PER TESTAROSSA

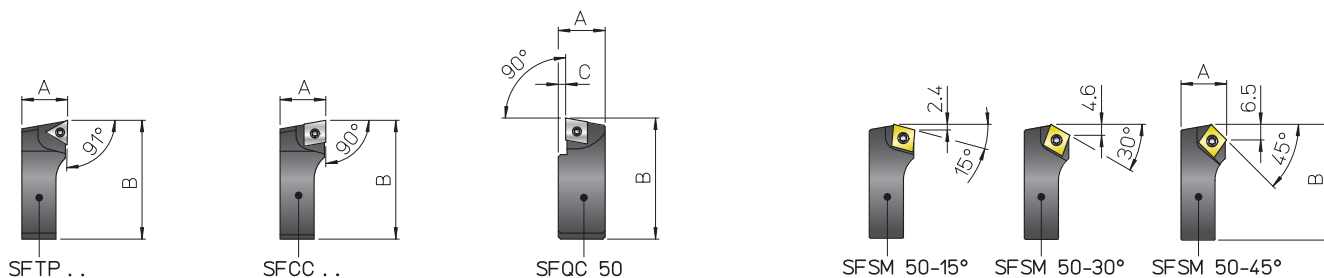
P 25  
Ø 28 ~ 54



REF.	CODE	Kg.
P25.63 TR...	435116250631	0.5
P25.105 TR...	435116251051	0.8

- BIT-HOLDERS FOR TESTAROSSA
- PLATTENHALTER FÜR TESTAROSSA
- PORTA-PLAQUITAS PARA TESTAROSSA
- PORTE-PLAQUETTES POUR TESTAROSSA
- SEGGI PER TESTAROSSA

SF

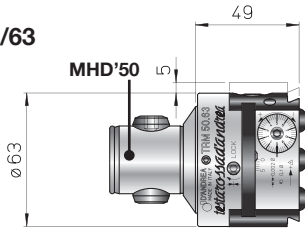


REF.	CODE	A	B	C					Kg.
SFTP 25	470500525001	10	26.5	-	TPGX 0902..	-	CS 250T	TORX T08	0.01
SFTP 32	470500532001	11.5	34.5	-	TPGX 1103..	-	CS 300890T	TORX T08	0.02
SFTP 50	470500550001	19	52	-	TPGX 1103..	-	CS 300890T	TORX T15	0.08
SFCC 25	470500525002	10	26.5	-	-	CCGT 0602..	TS 25	TORX T08	0.01
SFCC 32	470500532002	11.5	34.5	-	-	CCGT 09T3..	TS 4	TORX T15	0.02
SFCC 50	470500550002	19	52	-	-	CCGT 09T3..	TS 4	TORX T15	0.08
SFQC 50	470500550062	20.5	53	3	-	CCMT 09T3..	TS 4	TORXT15	0.1
SFSM 50-15°	470500550011	19	50.5	-	-	CCMT 09T3..	TS 4	TORXT15	0.07
SFSM 50-30°	470500550013								
SFSM 50-45°	470500550015								

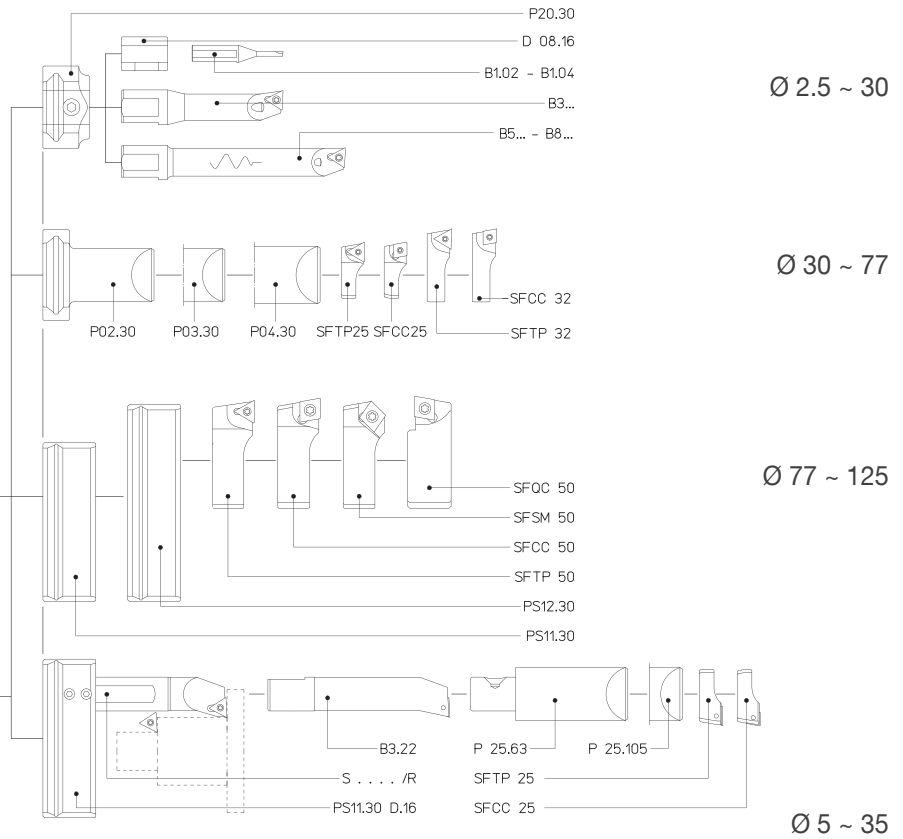
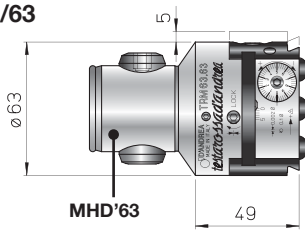


2 µm

**TRM 50/63**

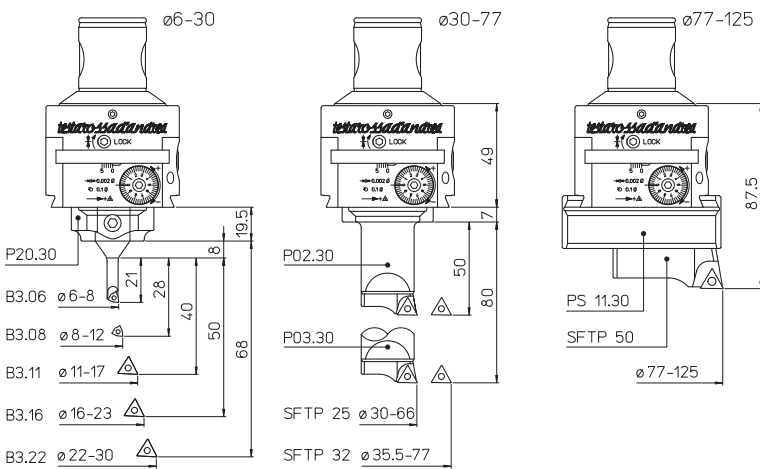


**TRM 63/63**



REF.	CODE	Kg.
TRM 50/63	455005000631	1.1
TRM 63/63	455006300631	1.5

**KIT K01**  
Ø 6 ~ 125



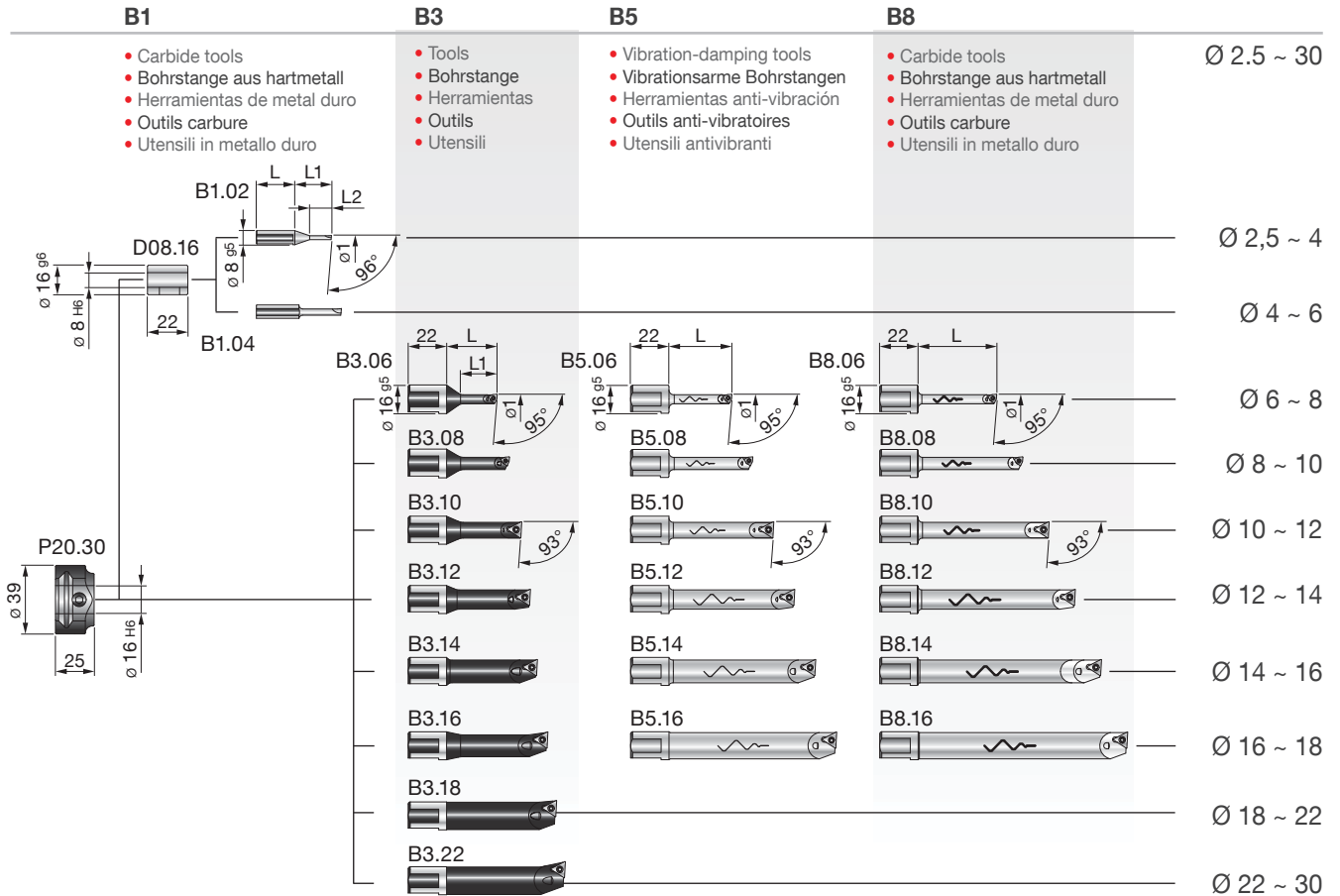
- 1 TRM../63
- 1 P20.30 1 B3.06 1 B3.22 5 TPGX 090202L DC100
- 1 PS11.30 1 B3.08 1 SFTP25 1 TPGX 110302L DC100
- 1 P02.30 1 B3.11 1 SFTP32 2 WCGT 020102L DC100
- 1 P03.30 1 B3.16 1 SFTP50

REF.	CODE	Ø
KIT K01 TRM 50/63	655005010632	6 ~ 125
KIT K01 TRM 63/63	655006310632	

119 120 116 241







REF.	CODE	Kg.
P20.30	431030160300	0.2

REF.	CODE	Kg.
D08.16	200560116082	0.02

REF.	CODE	Ø1	L	L1	L2	Kg.
B1.02	572010502001	2.5 ~ 4	22	21	12.5	0.02
B1.04	572010504001	4 ~ 6	24	24	-	

REF.	CODE	Ø1	L	L1	⚠	⚠	🔧	🔧	Kg.
B3.06	572010506001	6 ~ 8	29	21	WCGT 0201..	-	TS 21	TORX T06	0.035
B3.08	572010508001	8 ~ 10	36	28			TS 211		0.04
B3.10	572010510001	10 ~ 12	43	35	-	TPGX 0902..	CS 250 T	TORX T08	0.05
B3.11	572010511001	11 ~ 13	48	40					0.055
B3.12	572010512001	12 ~ 14	48	42					0.06
B3.14	572010514001	14 ~ 16	52	50					0.07
B3.16	572010516001	16 ~ 18	58	-	-	-	-	-	0.1
B3.18	572010518001	18 ~ 22	63	-					
B3.22	572010522001	22 ~ 30	68	-					

B5.06	572010506105	6 ~ 8	36	-	WCGT 0201..	-	TS 21	TORX T06	0.075
B5.08	572010508105	8 ~ 10	48				TS 211		0.09
B5.10	572010510105	10 ~ 12	60	-	TPGX 0902..	CS 250 T	TORX T08	0.1	
B5.12	572010512105	12 ~ 14	72					0.2	
B5.14	572010514105	14 ~ 16	84					0.3	
B5.16	572010516105	16 ~ 18	96					0.3	

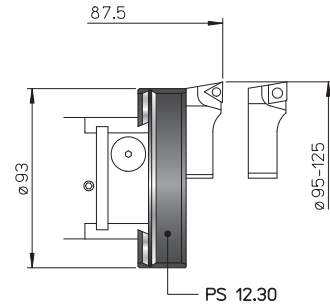
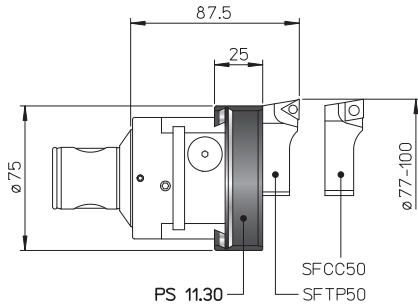
B8.06	572010506108	6 ~ 8	45	-	WCGT 0201..	-	TS 21	TORX T06	0.065
B8.08	572010508108	8 ~ 10	60				TS 211		0.08
B8.10	572010510108	10 ~ 12	75	-	TPGX 0902..	CS 250 T	TORX T08	0.1	
B8.12	572010512108	12 ~ 14	90					0.2	
B8.14	572010514108	14 ~ 16	105					0.3	
B8.16	572010516108	16 ~ 18	120					0.3	

### TRM 50/63

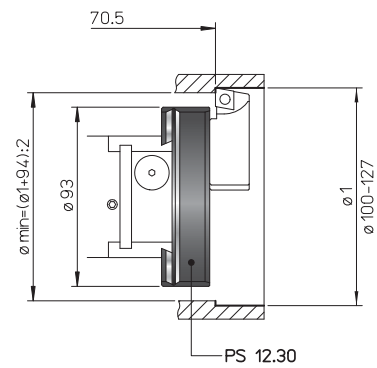
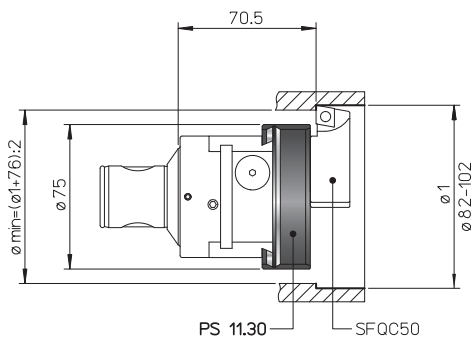
### TRM 63/63 $\varnothing 77 \sim 127$

- TOOLHOLDERS FOR TESTAROSSA
- GRUNDHALTER FÜR TESTAROSSA
- PORTAHERRAMIENTAS PARA TESTAROSSA
- PORTE-OUTILS POUR TESTAROSSA
- PORTAUTENSILI PER TESTAROSSA

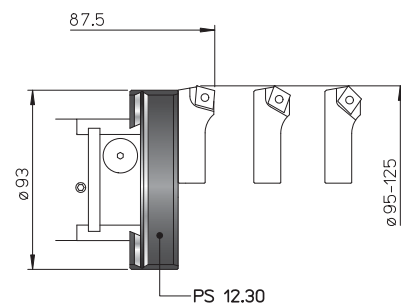
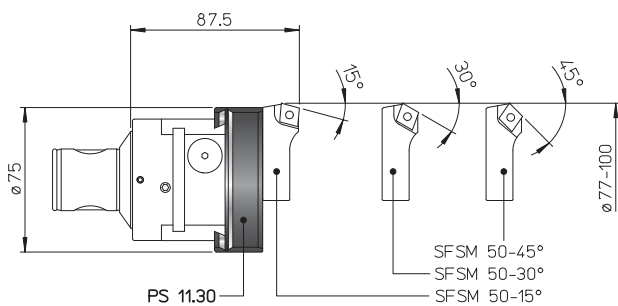
PS

 $\varnothing 77 \sim 125$ 

PS

 $\varnothing 82 \sim 127$ 

PS

 $\varnothing 77 \sim 125$ 

REF.	CODE	Kg.
PS 11.30	433030260750	0.4
PS 12.30	433030260950	0.5

119



125

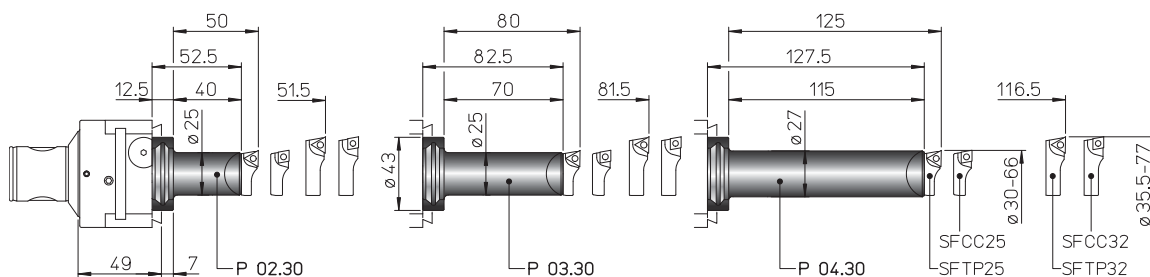


116



- TOOLHOLDERS FOR TESTAROSSA
- GRUNDHALTER FÜR TESTAROSSA
- PORTAHERRAMIENTAS PARA TESTAROSSA
- PORTE-OUTILS POUR TESTAROSSA
- PORTAUTENSILI PER TESTAROSSA

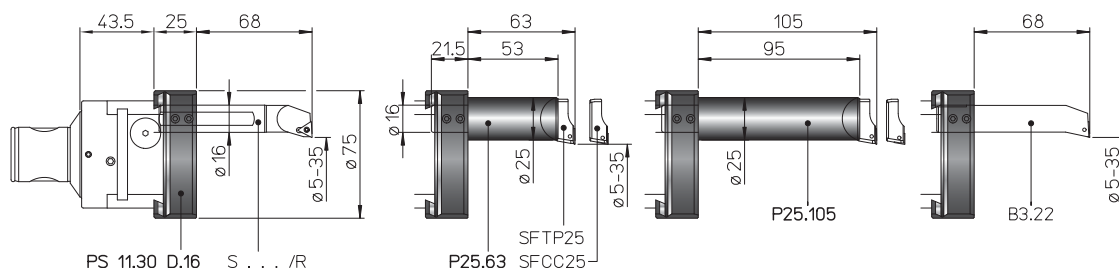
P  
Ø 30 ~ 77



REF.	CODE	Kg.
P02.30	431030250400	0.3
P03.30	431030250700	0.4
P04.30	431030251150	0.7

- TESTAROSSA EXTERNAL TURNING
- TESTAROSSA AUSSENDREHEN
- TESTAROSSA TORNEADO EXTERIOR
- TESTAROSSA TOURNAGE EXTÉRIEUR
- TESTAROSSA TORNITURA ESTERNA

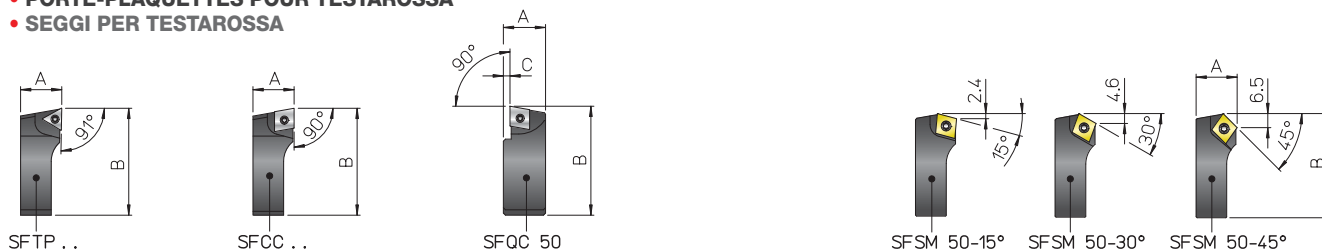
PS + P25  
Ø 5 ~ 35



REF.	CODE	Kg.
PS 11.30 D.16	433030260755	0.4
P25.63 TR...	435116250631	0.5
P25.105 TR...	435116251051	0.8

- BIT-HOLDERS FOR TESTAROSSA
- PLATTENHALTER FÜR TESTAROSSA
- PORTA-PLAQUITAS PARA TESTAROSSA
- PORTE-PLAQUETTES POUR TESTAROSSA
- SEGGI PER TESTAROSSA

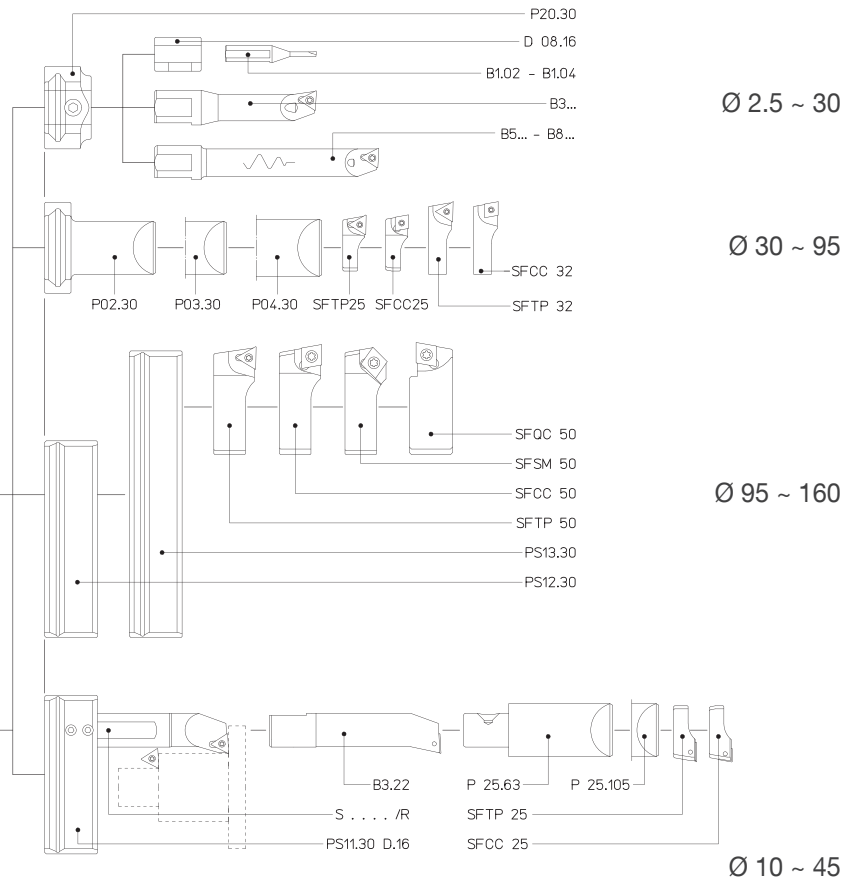
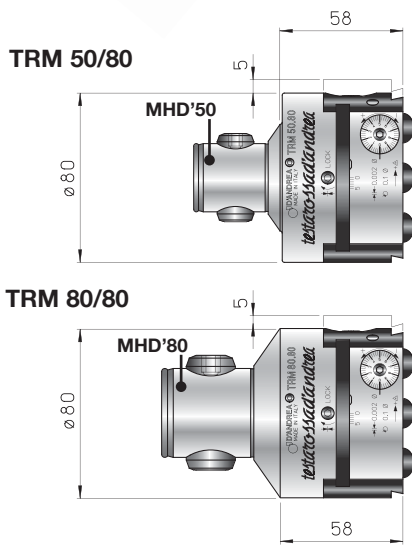
SF



REF.	CODE	A	B	C	△	⊖	⊖	⊖	Kg.
SFTP 25	470500525001	10	26.5	-	TPGX 0902..	-	CS 250T	TORX T08	0.01
SFTP 32	470500532001	11.5	34.5	-	-	-	-	-	0.02
SFTP 50	470500550001	19	52	-	TPGX 1103..	-	CS 300890T	-	0.08
SFCC 25	470500525002	10	26.5	-	-	CCGT 0602..	TS 25	TORX T08	0.01
SFCC 32	470500532002	11.5	34.5	-	-	-	-	-	0.02
SFCC 50	470500550002	19	52	-	-	CCGT 09T3..	TS 4	TORX T15	0.08
SFQC 50	470500550062	20.5	53	3	-	CCMT 09T3..	TS 4	TORXT15	0.1
SFSM 50-15°	470500550011	19	50.5	-	-	CCMT 09T3..	TS 4	TORXT15	0.07
SFSM 50-30°	470500550013								
SFSM 50-45°	470500550015								

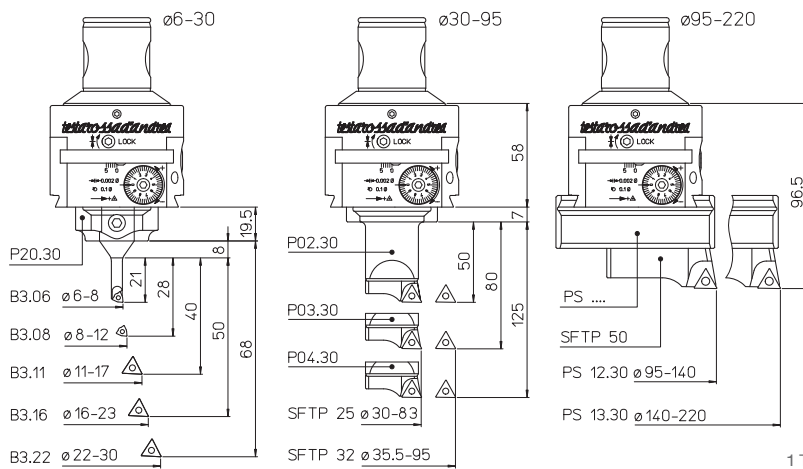


2 µm



REF.	CODE	Kg.
TRM 50/80	455005000801	2
TRM 80/80	455008000801	2.5

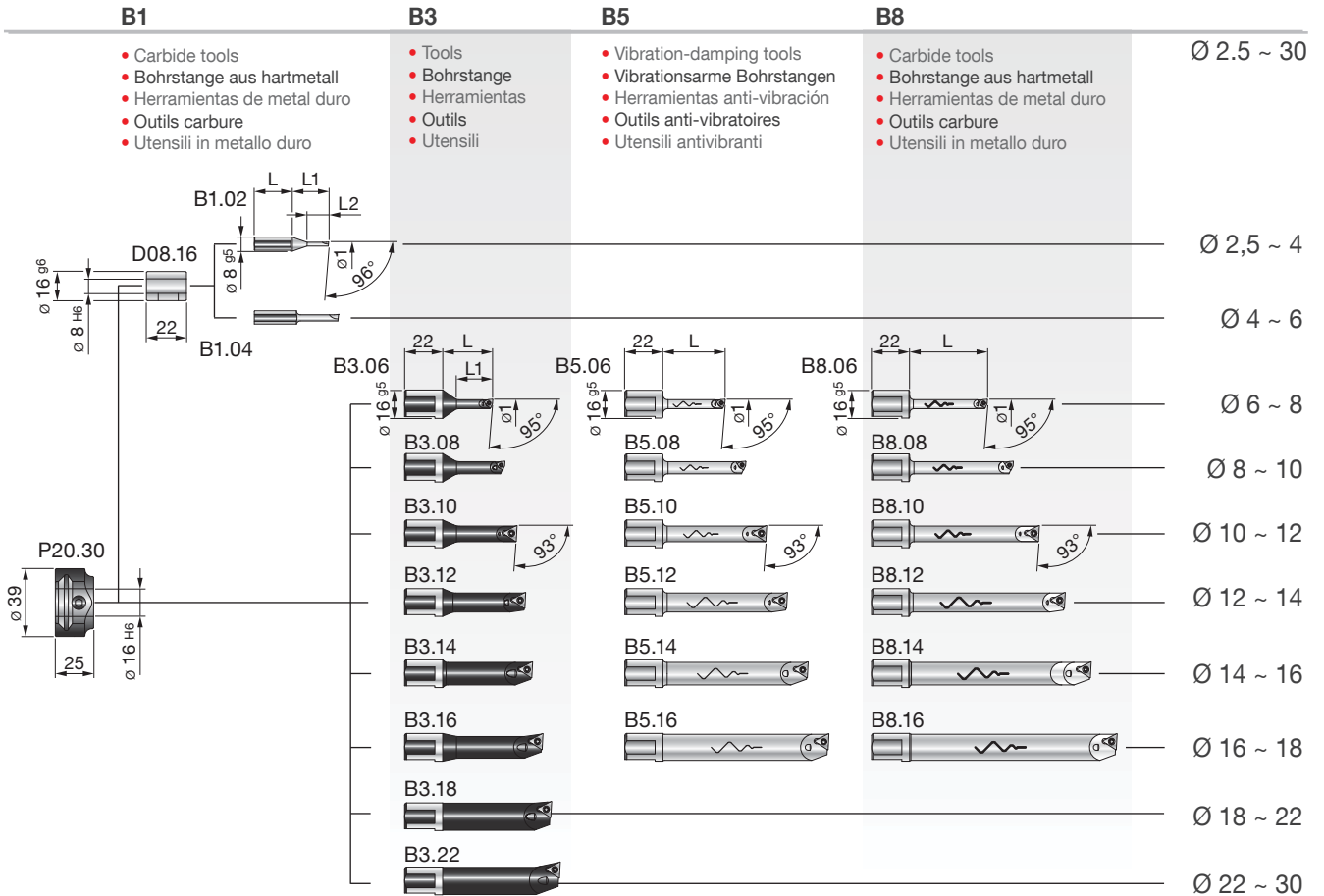
**KIT K01**  
 Ø 6 ~ 220



- 1 TRM../80  
 1 P20.30 1 P03.30 1 SFTP50 1 B3.16 5 TPGX 090202L DC100  
 1 PS12.30 1 P04.30 1 B3.06 1 B3.22 1 TPGX 110302L DC100  
 1 PS13.30 1 SFTP25 1 B3.08 2 WCGT 020102L DC100  
 1 P02.30 1 SFTP32 1 B3.11

REF.	CODE	Ø
KIT K01 TRM 50/80	655005010802	6 ~ 220
KIT K01 TRM 80/80	655008010802	





REF.	CODE	Kg.
P20.30	431030160300	0.2

REF.	CODE	Kg.
D08.16	200560116082	0.02

REF.	CODE	Ø1	L	L1	L2	Kg.
B1.02	572010502001	2.5 ~ 4	22	21	12.5	0.02
B1.04	572010504001	4 ~ 6	24	24	-	

REF.	CODE	Ø1	L	L1	⚠	⚠	🔩	🔩	Kg.		
B3.06	572010506001	6 ~ 8	29	21	WCGT 0201..	-	TS 21	TORX T06	0.035		
B3.08	572010508001	8 ~ 10	36	28					TS 211	0.04	
B3.10	572010510001	10 ~ 12	43	35			-	TPGX 0902..	CS 250 T	TORX T08	0.05
B3.11	572010511001	11 ~ 13	48	40							0.055
B3.12	572010512001	12 ~ 14	48	42	0.06						
B3.14	572010514001	14 ~ 16	52	50	0.07						
B3.16	572010516001	16 ~ 18	58	-	-	-	-	-	0.1		
B3.18	572010518001	18 ~ 22	63	-					0.1		
B3.22	572010522001	22 ~ 30	68	-	-	-	-	-	0.1		

B5.06	572010506105	6 ~ 8	36	-	WCGT 0201..	-	TS 21	TORX T06	0.075
B5.08	572010508105	8 ~ 10	48						TS 211
B5.10	572010510105	10 ~ 12	60		-	TPGX 0902..	CS 250 T	TORX T08	0.1
B5.12	572010512105	12 ~ 14	72						0.2
B5.14	572010514105	14 ~ 16	84						0.2
B5.16	572010516105	16 ~ 18	96						0.3

B8.06	572010506108	6 ~ 8	45	-	WCGT 0201..	-	TS 21	TORX T06	0.065
B8.08	572010508108	8 ~ 10	60						TS 211
B8.10	572010510108	10 ~ 12	75		-	TPGX 0902..	CS 250 T	TORX T08	0.1
B8.12	572010512108	12 ~ 14	90						0.2
B8.14	572010514108	14 ~ 16	105						0.2
B8.16	572010516108	16 ~ 18	120						0.3

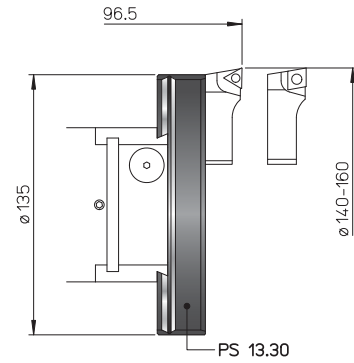
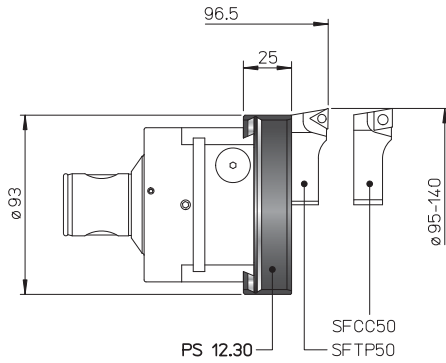


### TRM 50/80

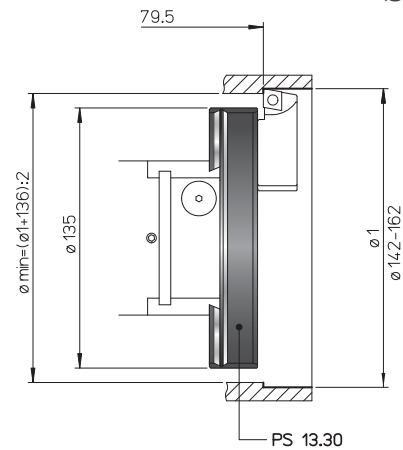
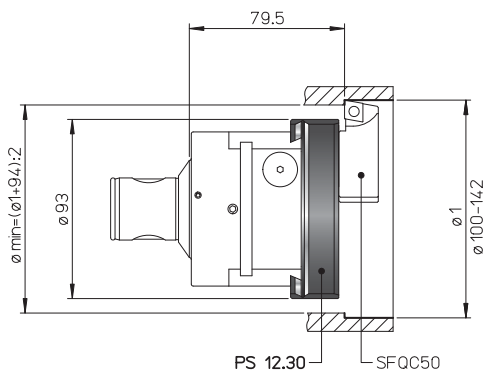
### TRM 80/80 $\varnothing 95 \sim 162$

- TOOLHOLDERS FOR TESTAROSSA
- GRUNDHALTER FÜR TESTAROSSA
- PORTAHERRAMIENTAS PARA TESTAROSSA
- PORTE-OUTILS POUR TESTAROSSA
- PORTAUTENSILI PER TESTAROSSA

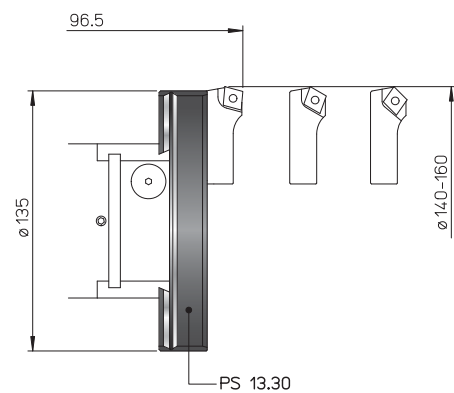
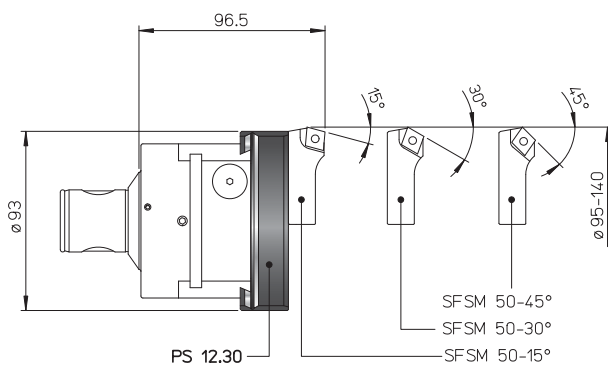
PS

 $\varnothing 95 \sim 160$ 

PS

 $\varnothing 100 \sim 162$ 

PS

 $\varnothing 95 \sim 160$ 

REF.	CODE	Kg.
PS 12.30	433030260950	0.5
PS 13.30	433030261400	0.7

119



125

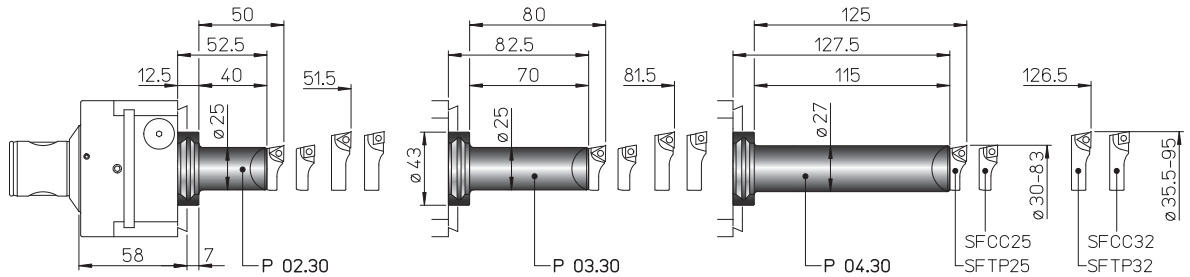


116



- TOOLHOLDERS FOR TESTAROSSA
- WERKZEUGE FÜR TESTAROSSA
- PORTAHERRAMIENTAS PARA TESTAROSSA
- PORTE-OUTILS POUR TESTAROSSA
- PORTAUTENSILI PER TESTAROSSA

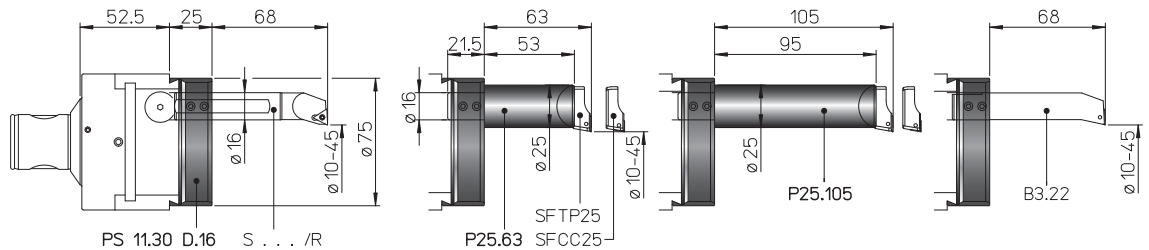
P  
Ø 30 ~ 95



REF.	CODE	Kg.
P02.30	431030250400	0.3
P03.30	431030250700	0.4
P04.30	431030251150	0.7

- TESTAROSSA EXTERNAL TURNING
- TESTAROSSA AUSSENDREHEN
- TESTAROSSA TORNEADO EXTERIOR
- TESTAROSSA TOURNAGE EXTÉRIEUR
- TESTAROSSA TORNITURA ESTERNA

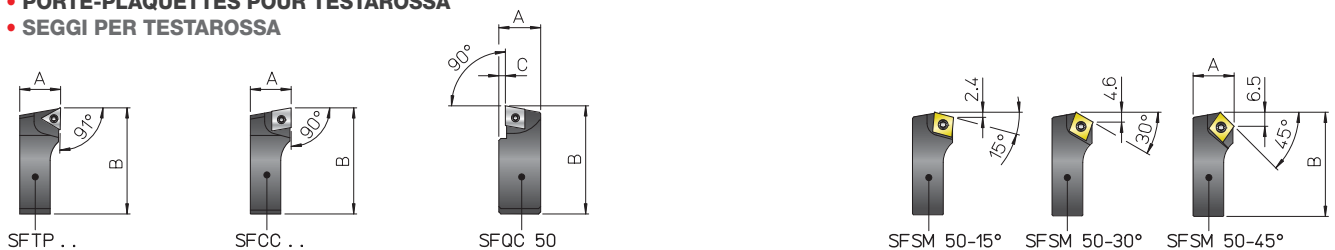
PS + P25  
Ø 10 ~ 45



REF.	CODE	Kg.
PS 11.30 D.16	433030260755	0.4
P25.63 TR...	435116250631	0.5
P25.105 TR...	435116251051	0.8

- BIT-HOLDERS FOR TESTAROSSA
- PLATTENHALTER FÜR TESTAROSSA
- PORTA-PLAQUITAS PARA TESTAROSSA
- PORTE-PLAQUETTES POUR TESTAROSSA
- SEGGI PER TESTAROSSA

SF



REF.	CODE	A	B	C	△	□	⊥	⌘	Kg.
SFTP 25	470500525001	10	26.5		TPGX 0902..	-	CS 250T	TORX T08	0.01
SFTP 32	470500532001	11.5	34.5						0.02
SFTP 50	470500550001	19	52		TPGX 1103..	-	CS 300890T		0.08
SFCC 25	470500525002	10	26.5			CCGT 0602..	TS 25	TORX T08	0.01
SFCC 32	470500532002	11.5	34.5						0.02
SFCC 50	470500550002	19	52			CCGT 09T3..	TS 4	TORX T15	0.08
SFQC 50	470500550062	20.5	53	3		CCMT 09T3..	TS 4	TORXT15	0.1
SFSM 50-15°	470500550011	19	50.5			CCMT 09T3..	TS 4	TORXT15	0.07
SFSM 50-30°	470500550013								
SFSM 50-45°	470500550015								

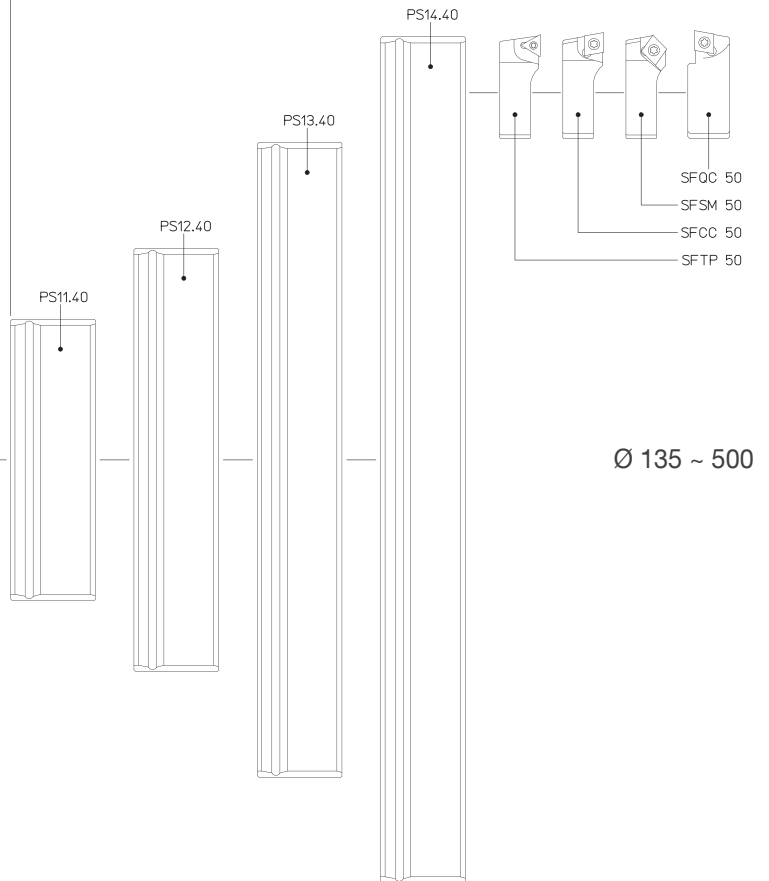
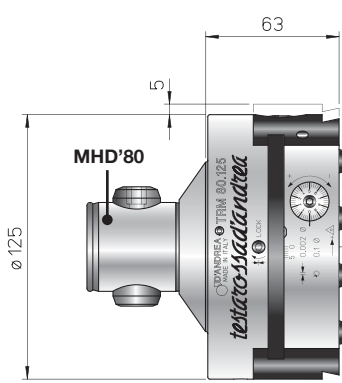
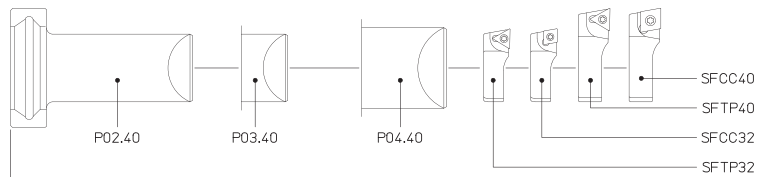
# D'ANDREA

## MODULHARD'ANDREA

2 µm



Ø 36 ~ 138



Ø 135 ~ 500

REF.	CODE	Kg.
TRM 80/125	455008001251	5.5

119



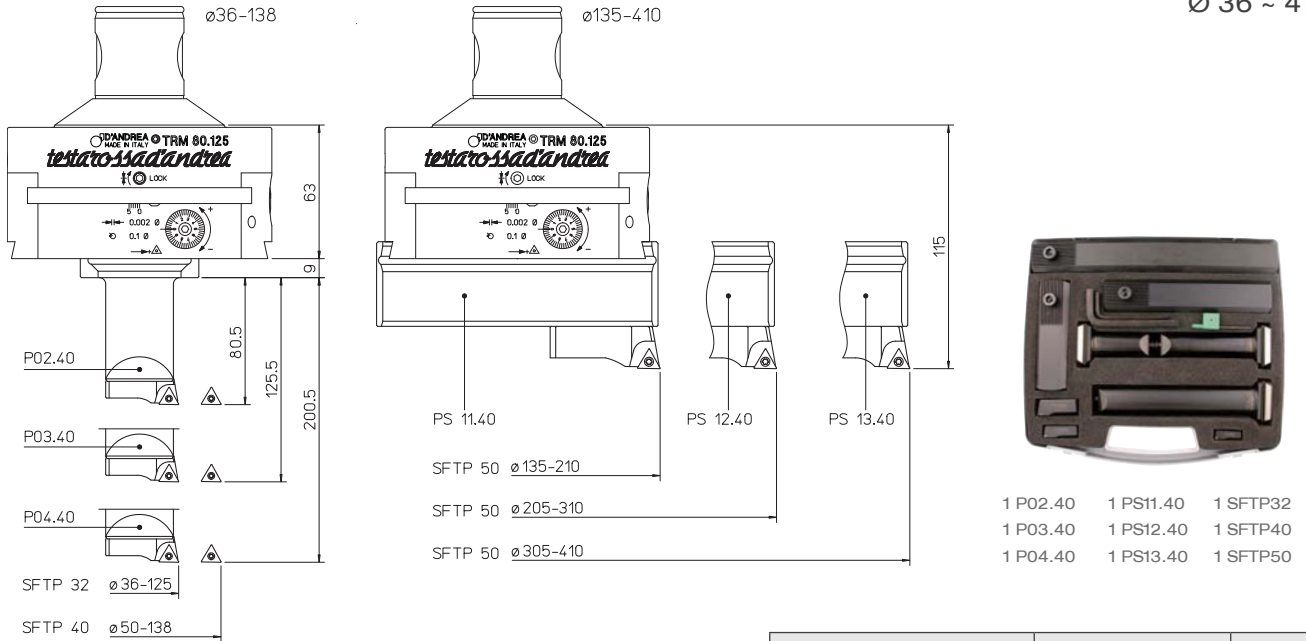
120



116



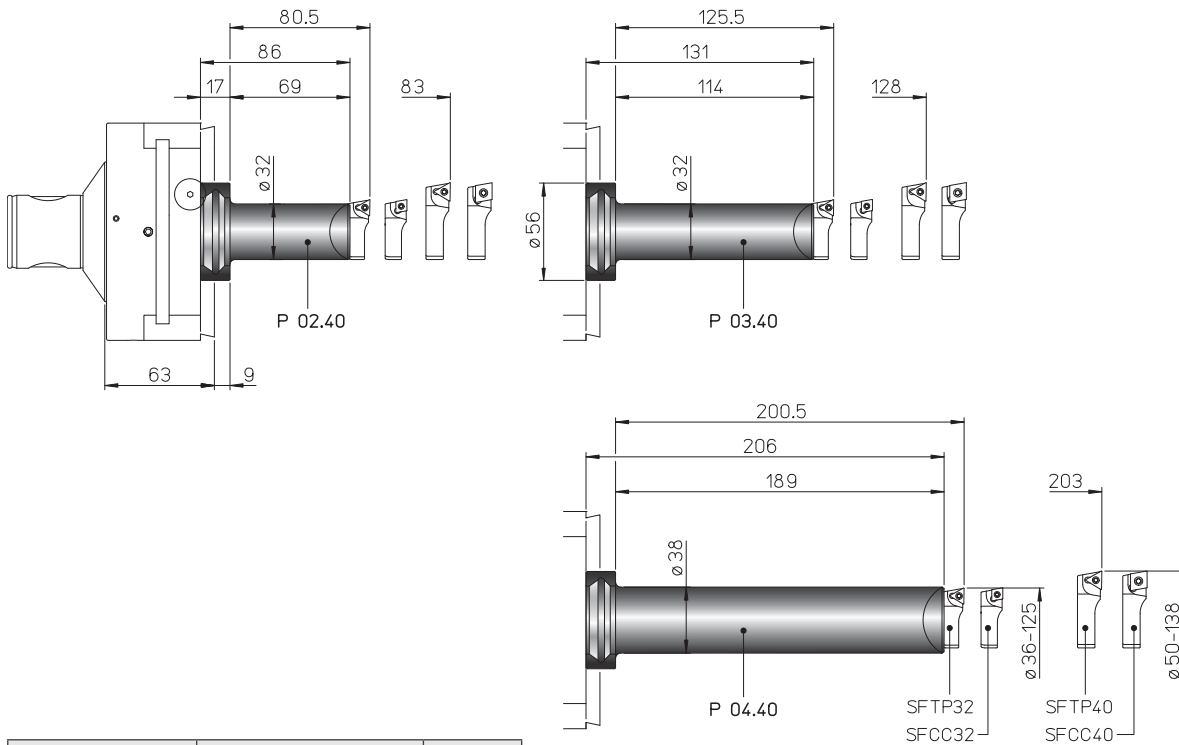
**KIT K03**  
Ø 36 ~ 410



- 1 P02.40    1 PS11.40    1 SFTP32
- 1 P03.40    1 PS12.40    1 SFTP40
- 1 P04.40    1 PS13.40    1 SFTP50

REF.	CODE	Ø
KIT K03 TRM 80/125	655012500030	36 ~ 410

**P**  
Ø 36 ~ 138

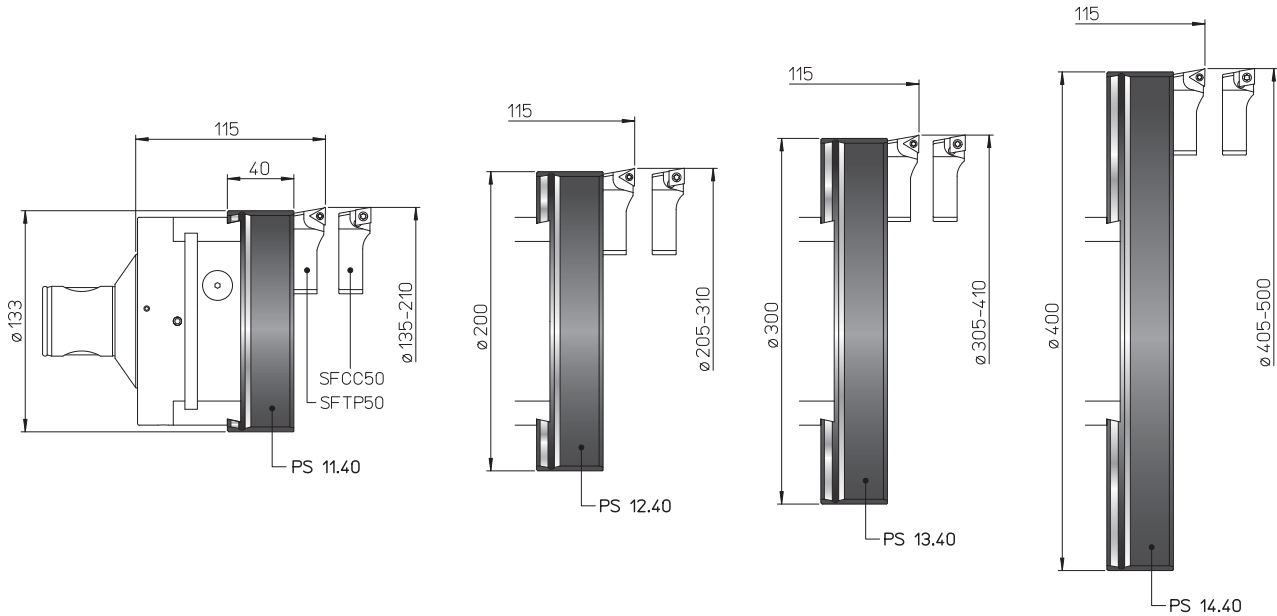


REF.	CODE	Kg.
P02.40	431040320700	0.7
P03.40	431040321150	1
P04.40	431040321900	2

- TOOLHOLDERS FOR TESTAROSSA
- GRUNDHALTER FÜR TESTAROSSA
- PORTAHERRAMIENTAS PARA TESTAROSSA
- PORTE-OUTILS POUR TESTAROSSA
- PORTAUTENSILI PER TESTAROSSA

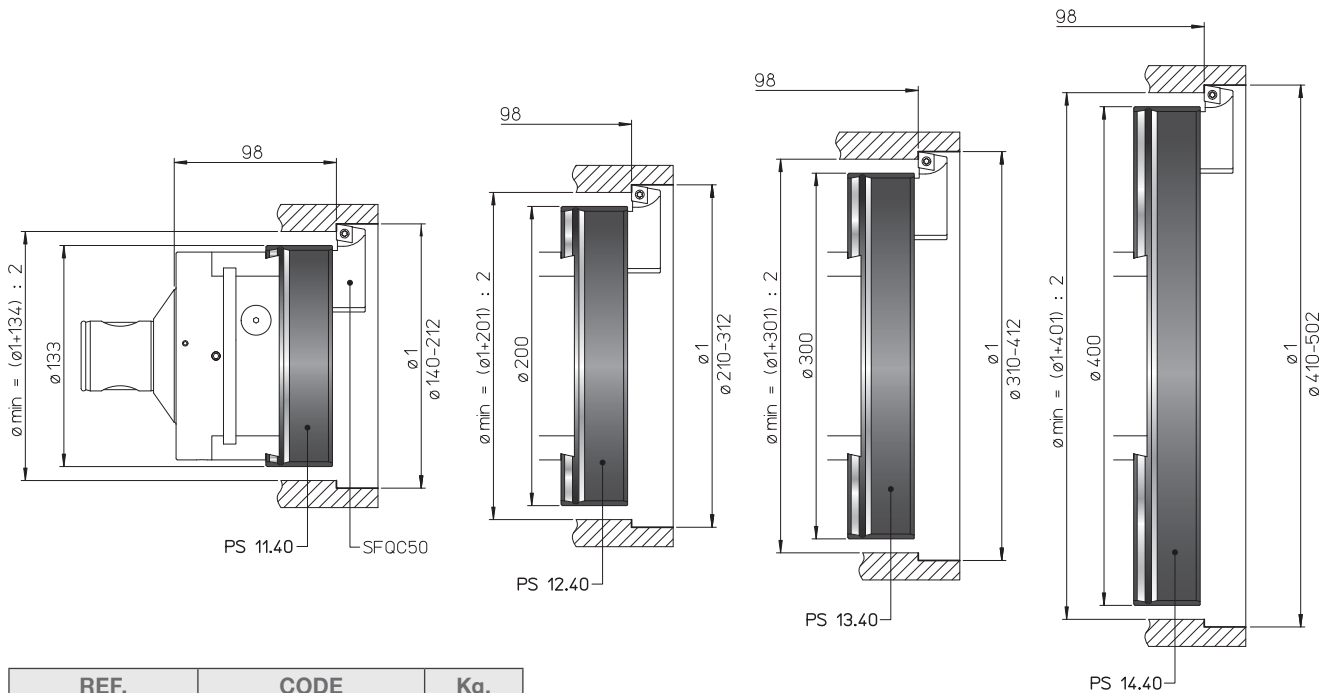
PS

Ø 135 ~ 500



PS

Ø 140 ~ 502



REF.	CODE	Kg.
PS 11.40	433040351500	1.5
PS 12.40	433040352300	2.4
PS 13.40	433040353300	3.5
PS 14.40	433040354000	4.6

119



125



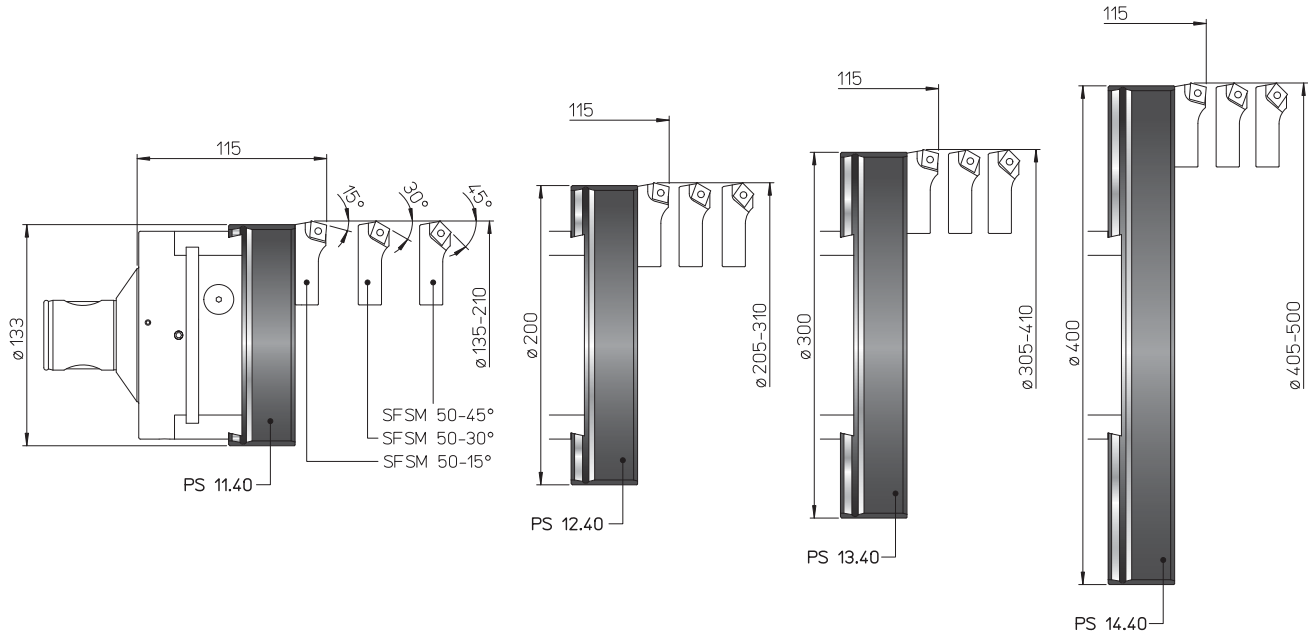
116





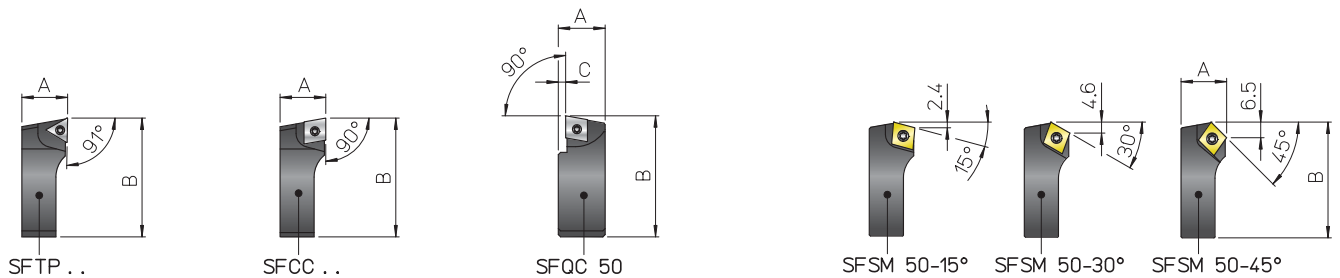
- TOOLHOLDERS FOR TESTAROSSA
- GRUNDHALTER FÜR TESTAROSSA
- PORTAHERRAMIENTAS PARA TESTAROSSA
- PORTE-OUTILS POUR TESTAROSSA
- PORTAUTENSILI PER TESTAROSSA

PS  
Ø 135 ~ 500



- BIT-HOLDERS FOR TESTAROSSA
- PLATTENHALTER FÜR TESTAROSSA
- PORTA-PLAQUITAS PARA TESTAROSSA
- PORTE-PLAQUETTES POUR TESTAROSSA
- SEGGI PER TESTAROSSA

SF

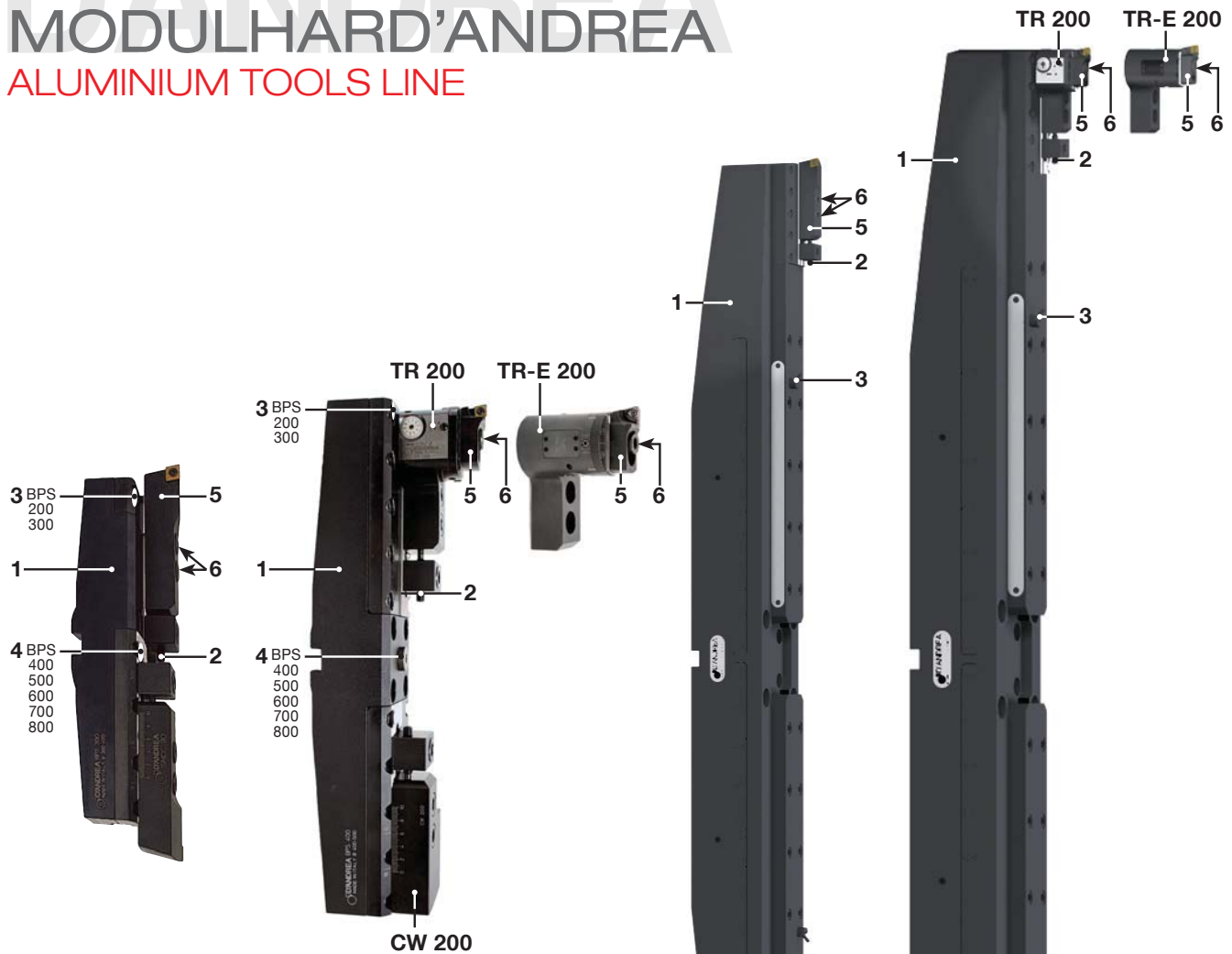


REF.	CODE	A	B	C	△	□	⌋	⌋	Kg.
SFTP 32	470500532001	11.5	34.5	-	TPGX 0902..	-	CS 250T	TORX T08	0.02
SFTP 40	470500540001	14	44	-	TPGX 1103..	-	CS 300890T		0.04
SFTP 50	470500550001	19	52	-	-	-	-		0.08
SFCC 32	470500532002	11.5	34.5	-	-	CCGT 0602..	TS 25	TORX T08	0.02
SFCC 40	470500540002	14	44	-	-	CCGT 09T3..	TS 4	TORX T15	0.04
SFCC 50	470500550002	19	52	-	-	-	-	-	0.08
SFQC 50	470500550062	20.5	53	3	-	CCMT 09T3..	TS 4	TORXT15	0.1
SFSM 50-15°	470500550011	19	50.5	-	-	CCMT 09T3..	TS 4	TORXT15	0.07
SFSM 50-30°	470500550013								
SFSM 50-45°	470500550015								

# D'ANDREA

## MODULHARD'ANDREA

### ALUMINIUM TOOLS LINE



- |  |  |
|--|--|
| <p><b>1</b></p> <ul style="list-style-type: none"> <li>• Body</li> <li>• Körper</li> <li>• Cuerpo</li> <li>• Corps</li> <li>• Corpo</li> </ul> <p><b>2</b></p> <ul style="list-style-type: none"> <li>• Setting screws</li> <li>• Einstellschraube</li> <li>• Tornillo de regulación</li> <li>• Vis de réglage</li> <li>• Vite di regolazione</li> </ul> <p><b>3</b></p> <ul style="list-style-type: none"> <li>• Coolant outlets</li> <li>• Kühlmittelaustritt</li> <li>• Agujeros salida refrigerante</li> <li>• Sortie du liquide d'arrosage</li> <li>• Fori uscita refrigerante</li> </ul> | <p><b>4</b></p> <ul style="list-style-type: none"> <li>• Coolant outlets 1/4 GAS</li> <li>• Kühlmittelaustritt 1/4 GAS</li> <li>• Agujeros salida refrigerante 1/4 GAS</li> <li>• Sortie du liquide d'arrosage 1/4 GAS</li> <li>• Fori uscita refrigerante 1/4 GAS</li> </ul> <p><b>5</b></p> <ul style="list-style-type: none"> <li>• Bit holder</li> <li>• Plattenhalter</li> <li>• Portaplaquita</li> <li>• Porte-plaquettes</li> <li>• Seggio portainseriti</li> </ul> <p><b>6</b></p> <ul style="list-style-type: none"> <li>• Tools clamp screws</li> <li>• Werkzeugklemm-schrauben</li> <li>• Tornillos bloqueo herramienta</li> <li>• Vis blocage outil</li> <li>• Viti bloccaggio utensile</li> </ul> |
|--|--|

**GB** The BPS double-bit crossbars cover a working area from  $\varnothing$  200 - 2700 mm. The BPS double-bit crossbars are constructed in Aluminium and mounted on a steel double-bit plate.

**D** Die Zweischneider BPS bedecken ein Arbeitsfeld von  $\varnothing$  200 - 2700 mm. Die Bohrschienen BPS bestehen aus Aluminium auf welches die Sitzhalterungsplatte aus Stahl befestigt wird.

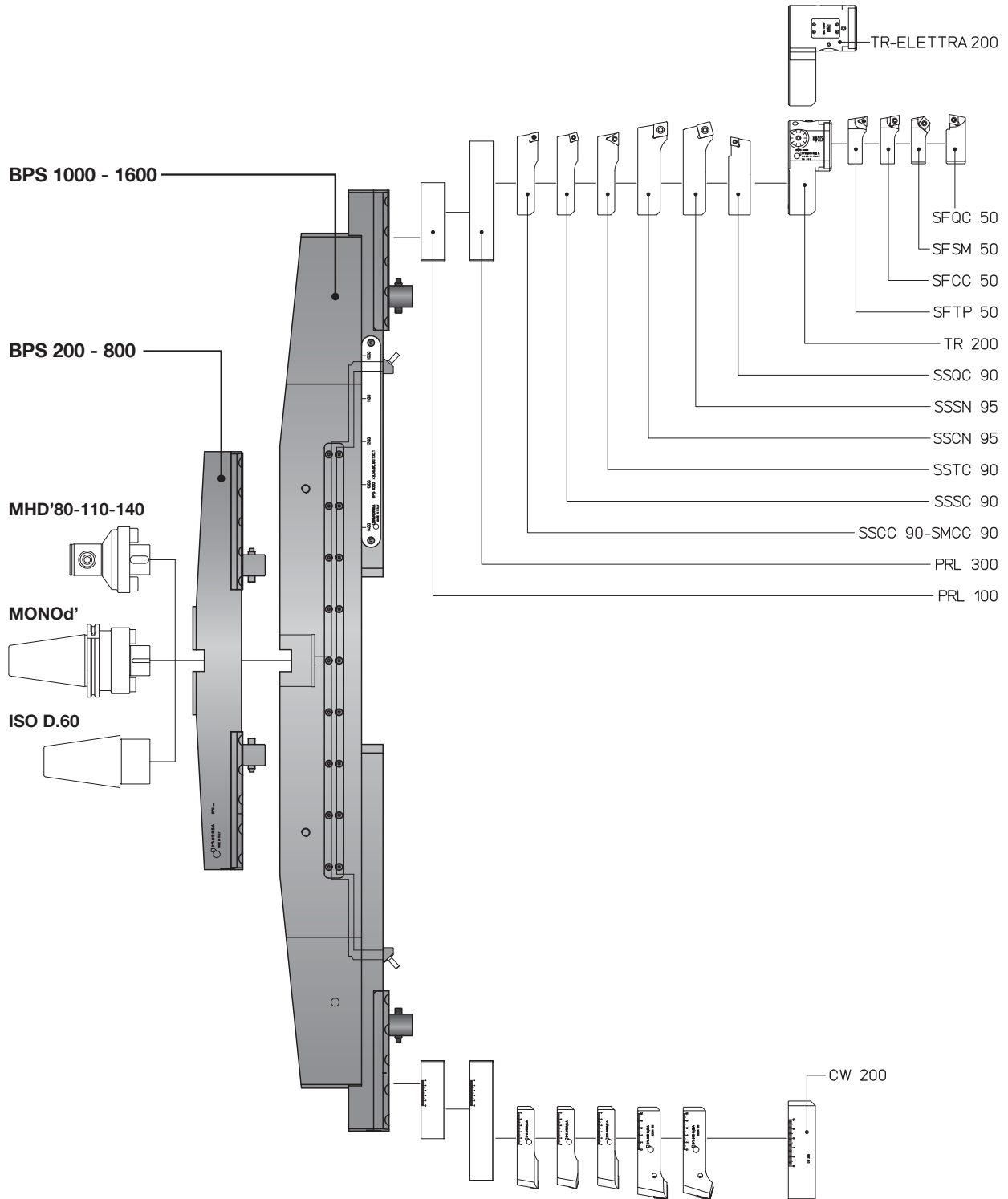
**E** Las barras porta-asiento BPS cubren un campo de trabajo de 200 a 2700 mm de diámetro. Las barras porta-asiento BPS están realizadas en aluminio, sobre el cual se fija la placa porta-asiento de acero.

**F** Les barres porte logement BPS couvrent un intervalle de travail de  $\varnothing$  200 - 2700 mm. Les barres porte logement BPS sont réalisées en aluminium sur lequel est fixée la plaquette porte logement en acier.

**I** Le barre portaseggio BPS coprono un campo di lavoro da  $\varnothing$  200 - 2700 mm. Le barre portaseggio BPS sono costruite in alluminio sul quale viene fissata la piastra portaseggio in acciaio.



- DOUBLE-BIT CROSSBARS FOR BIG DIAMETERS
- ZWEISCHNEIDERBOHRSCIENEN FÜR GROSSER DURCHMESSER
- BARRAS PORTA-ASIENTO DE DOS CORTES
- SEMELLES POUR A GRANDS DIAMÈTRES
- BARRE PORTASEGGIO PER GRANDI DIAMETRI



REF.	CODE	Kg.
BPS 200	435540881980	3.2
BPS 300	435540882980	3.9
BPS 400	435540883980	6.9
BPS 500	435560884940	9.4
BPS 600	435560885940	9.9

REF.	CODE	Kg.
BPS 700	435560886940	11.2
BPS 800	435560887940	15.2
BPS 1000 GD	435560901001	55
BPS 1150 GD	435560901151	70
BPS 1600 GD	435560901601	115

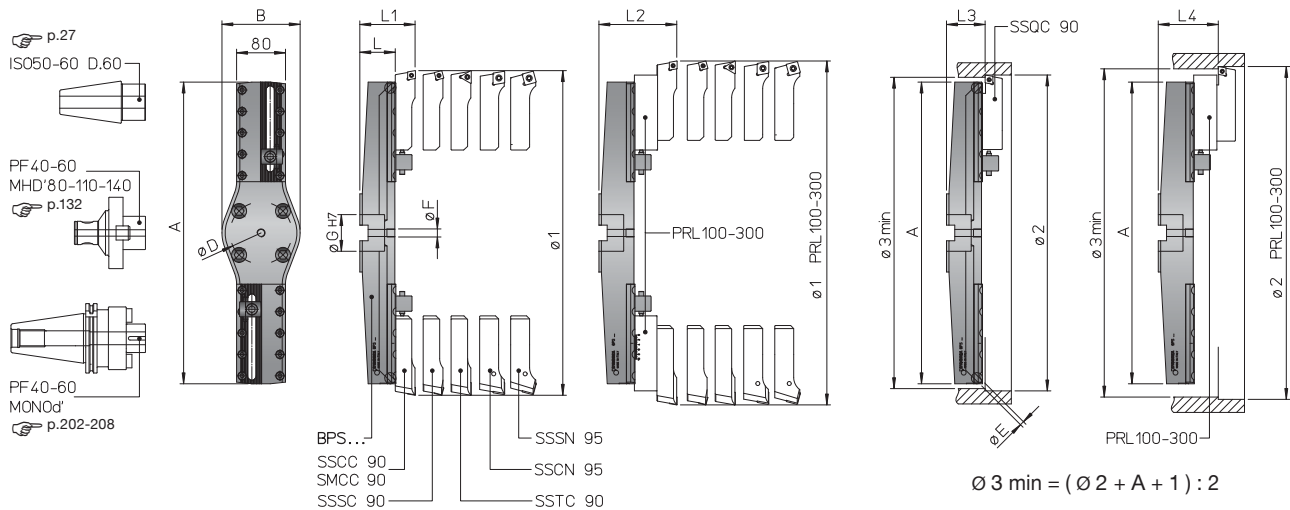
# D'ANDREA

## MODULHARD'ANDREA

### ALUMINIUM TOOLS LINE

**BPS 200~800** Ø 200 ~ 1200

- DOUBLE-BIT BORING CROSSBARS
- ZWEISCHNEIDER-BOHRSCHIENEN
- BARRAS PORTA-ASIENTO DE DOS CORTES
- LES SEMELLES PORTE-LOGEMENT À DEUX TRANCHANTS
- BARRE PORTASEGGIO BITAGLIANTI



	BPS 200	BPS 300	BPS 400	BPS 500	BPS 600	BPS 700	BPS 800
A	194	288	394	494	594	694	794
B	-			128			
Ø D	(4xM12) 66.7			(4xM16) 101.6			
Ø E	2.5		-				
Ø F	-		1/4 GAS				
Ø G	40			60			
Ø 1	200 ~ 300	300 ~ 400	400 ~ 500	500 ~ 600	600 ~ 700	700 ~ 800	800 ~ 900
Ø 1 PRL 100	300 ~ 400	400 ~ 500	500 ~ 600	600 ~ 700	700 ~ 800	800 ~ 900	900 ~ 1000
Ø 1 PRL 300	400 ~ 600	500 ~ 700	600 ~ 800	700 ~ 900	800 ~ 1000	900 ~ 1100	1000 ~ 1200
Ø 2	202 ~ 302	302 ~ 402	402 ~ 502	502 ~ 602	602 ~ 702	702 ~ 802	802 ~ 902
Ø 2 PRL 100	302 ~ 402	402 ~ 502	502 ~ 602	602 ~ 702	702 ~ 802	802 ~ 902	902 ~ 1002
Ø 2 PRL 300	402 ~ 602	502 ~ 702	602 ~ 802	702 ~ 902	802 ~ 1002	902 ~ 1102	1002 ~ 1202
L	54		61	69	71	74	80
L1 S...90	86		93	101	103	106	112
L1 S...95	94		101	109	111	114	120
L2 PRL 100 S...90	116		123	131	133	136	142
L2 PRL 300 S...90	126		133	141	143	146	152
L2 PRL 100 S...95	124		131	139	141	144	150
L2 PRL 300 S...95	134		141	149	151	154	160
L3 SSQC 90	56.5		63.5	71.5	73.5	76.5	82.5
L4 PRL 100 SSQC 90	86.5		93.5	101.5	103.5	106.5	112.5
L4 PRL 300 SSQC 90	96.5		103.5	111.5	113.5	116.5	122.5

119



126



116



- DOUBLE-BIT CROSSBARS FOR BIG DIAMETER FINISH
- ZWEISCHNEIDER-BOHRSCIENEN FÜR FEINBEARBEITUNGEN GROSSER DURCHMESSER
- BARRAS PORTA-ASIENTO DE DOS CORTES
- LES SEMELLES PORTE-LOGEMENT POUR FINISSAGE DES GRANDS DIAMÈTRES
- BARRE PORTASEGGIO PER FINITURA GRANDI DIAMETRI



	BPS 200	BPS 300	BPS 400	BPS 500	BPS 600	BPS 700	BPS 800					
A	194	288	394	494	594	694	794					
B	-			128								
Ø D	(4xM12) 66.7				(4xM16) 101.6							
Ø E	2.5		-									
Ø F	-		1/4 GAS									
Ø G	40			60								
Ø 1	200~300	300~400	400 ~ 500	500 ~ 600	600 ~ 700	700 ~ 800	800 ~ 900					
Ø 1 PRL 100	300~400	400~500	500 ~ 600	600 ~ 700	700 ~ 800	800 ~ 900	900 ~ 1000					
Ø 1 PRL 300	400~600	500~700	600 ~ 800	700 ~ 900	800 ~ 1000	900 ~ 1100	1000 ~ 1200					
Ø 2	202~302	302~402	402 ~ 502	502 ~ 602	602 ~ 702	702 ~ 802	802 ~ 902					
Ø 2 PRL 100	302~402	402~502	502 ~ 602	602 ~ 702	702 ~ 802	802 ~ 902	902 ~ 1002					
Ø 2 PRL 300	402~602	502~702	602 ~ 802	702 ~ 902	802 ~ 1002	902 ~ 1102	1002 ~ 1202					
L	54		61	69	71	74	80					
	TR-200	TR-E200	TR-200	TR-E200	TR-200	TR-E200	TR-200	TR-E200	TR-200	TR-E200	TR-200	TR-E200
L1	120	147	127	154	135	162	137	164	140	167	146	173
L2 PRL 100	150	177	157	184	165	192	167	194	170	197	176	203
L2 PRL 300	160	187	167	194	175	202	177	204	180	207	186	213
L3	103	130	110	137	118	145	120	147	123	150	129	156
L4 PRL 100	133	160	140	167	148	175	150	177	153	180	159	186
L4 PRL 300	143	170	150	177	158	185	160	187	163	190	169	196

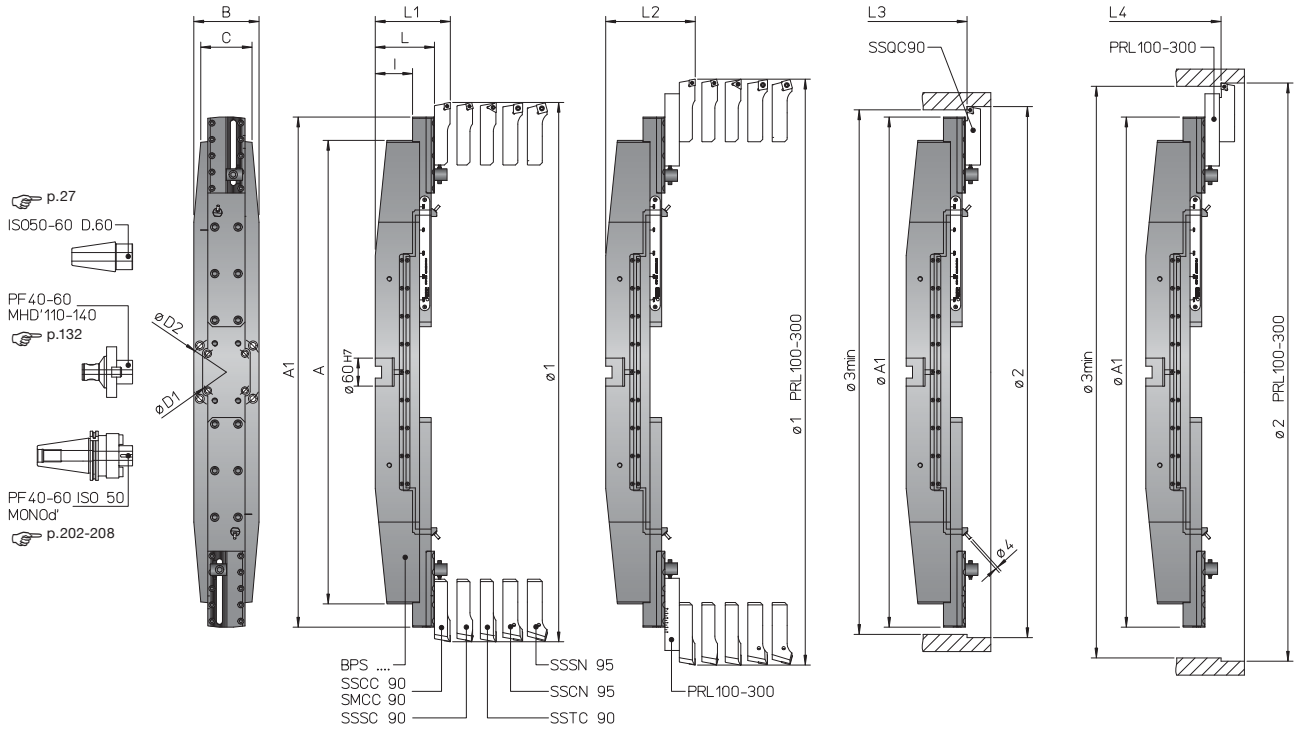




## BPS 1000~1600 GD

Ø 1000 ~ 2700

- DOUBLE-BIT BORING CROSSBARS
- ZWEISCHNEIDER-BOHRSCHIENEN
- BARRAS PORTA-ASIENTO DE DOS CORTES
- LES SEMELLES PORTE-LOGEMENT À DEUX TRANCHANTS
- BARRE PORTASEGGIO BITAGLIANTI



$$\varnothing 3 \text{ min} = (\varnothing 2 + A1 + 1) : 2$$

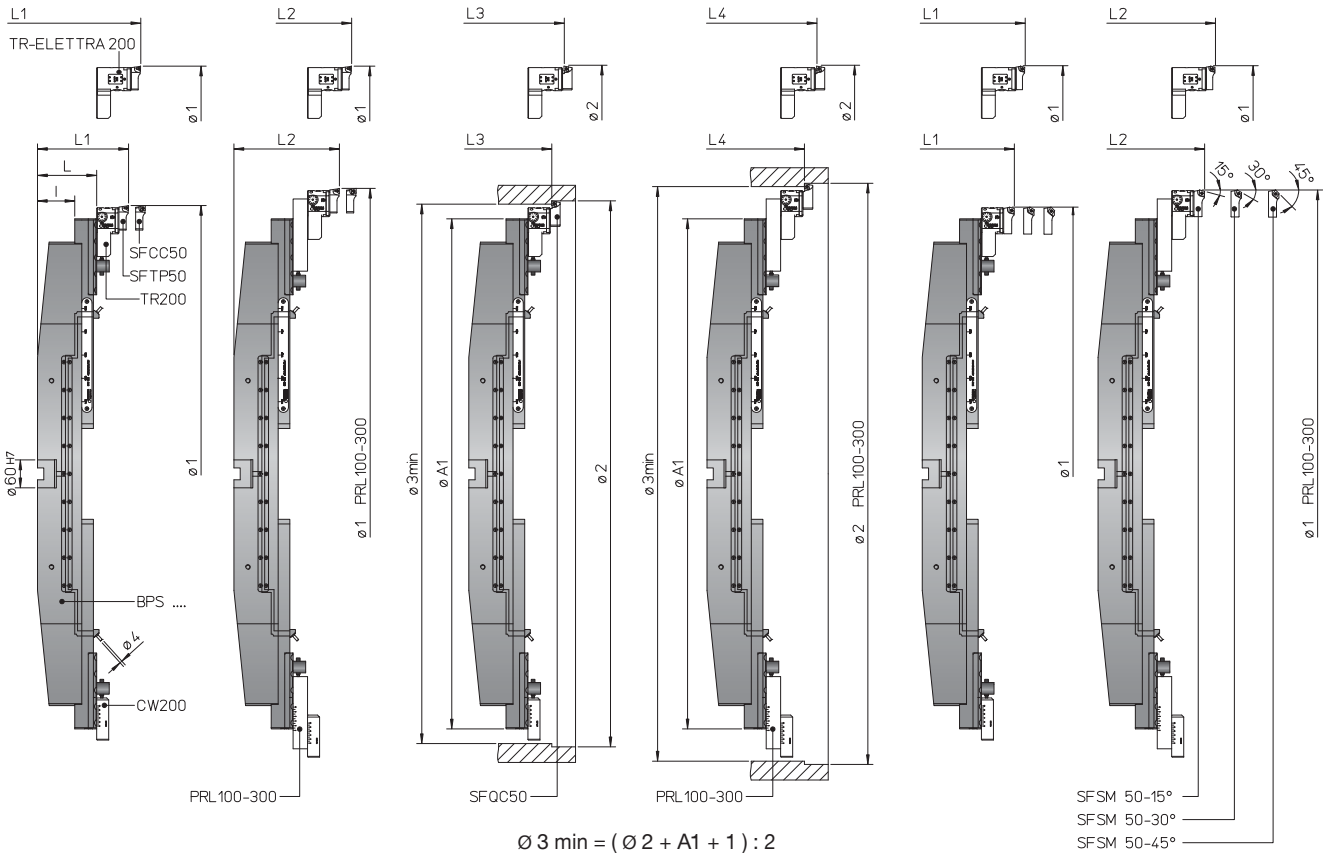
	BPS 1000 GD	BPS 1150 GD	BPS 1600 GD
A	995		1595
A1	995 ~ 1395	1495 ~ 1695	1595 ~ 2295
B	140		170
C	110		130
Ø D1	(4xM16) 101.6		
Ø D2	-		(4xM20) 177.8
Ø 1	1000 ~ 1500	1500 ~ 1800	1600 ~ 2400
Ø 1 PRL 100	1100 ~ 1600	1600 ~ 1900	1700 ~ 2500
Ø 1 PRL 300	1200 ~ 1800	1700 ~ 2100	1800 ~ 2700
Ø 2	1002 ~ 1502	1502 ~ 1802	1602 ~ 2402
Ø 2 PRL 100	1102 ~ 1602	1602 ~ 1902	1702 ~ 2502
Ø 2 PRL 300	1202 ~ 1802	1702 ~ 2102	1802 ~ 2702
I	80		105
L	126		151
L1 S...90	158		183
L1 S...95	166		191
L2 PRL 100 S...90	188		213
L2 PRL 300 S...90	198		223
L2 PRL 100 S...95	196		221
L2 PRL 300 S...95	206		231
L3 SSQC 90	128,5		153,5
L4 PRL 100 SSQC 90	158,5		183,5
L4 PRL 300 SSQC 90	168,5		193,5



# BPS 1000~1600 GD

Ø 1000 ~ 2700

- DOUBLE-BIT CROSSBARS FOR BIG DIAMETER FINISH
- ZWEISCHNEIDER-BOHRSCHIENEN FÜR FEINBEARBEITUNGEN GROSSER DURCHMESSER
- BARRAS PORTA-ASIENTO DE DOS CORTES
- LES SEMELLES PORTE-LOGEMENT POUR FINISSAGE DES GRANDS DIAMÈTRES
- BARRE PORTASEGGIO PER FINITURA GRANDI DIAMETRI

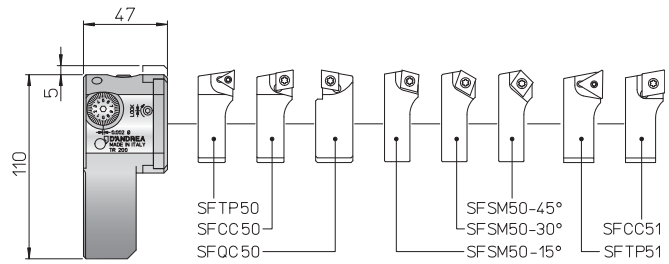


	BPS 1000 GD		BPS 1150 GD		BPS 1600 GD	
A	995				1595	
A1	995 ~ 1395		1495 ~ 1695		1595 ~ 2295	
B	140				170	
C	110				130	
Ø D1	(4xM16) 101.6					
Ø D2					(4xM20) 177.8	
Ø 1	1000 ~ 1500		1500 ~ 1800		1600 ~ 2400	
Ø 1 PRL 100	1100 ~ 1600		1600 ~ 1900		1700 ~ 2500	
Ø 1 PRL 300	1200 ~ 1800		1700 ~ 2100		1800 ~ 2700	
Ø 2	1002 ~ 1502		1502 ~ 1802		1602 ~ 2402	
Ø 2 PRL 100	1102 ~ 1602		1602 ~ 1902		1702 ~ 2502	
Ø 2 PRL 300	1202 ~ 1802		1702 ~ 2102		1802 ~ 2702	
I	80				105	
	TR-200	TR-ELETTRA200	TR-200	TR-ELETTRA200	TR-200	TR-ELETTRA200
L	126	153	126	153	151	178
L1	192	219	192	219	217	244
L2 PRL 100	222	249	222	249	247	274
L2 PRL 300	232	259	232	259	257	284
L3	175	202	175	202	200	227
L4 PRL 100	205	232	205	232	230	257
L4 PRL 300	215	242	215	242	240	267

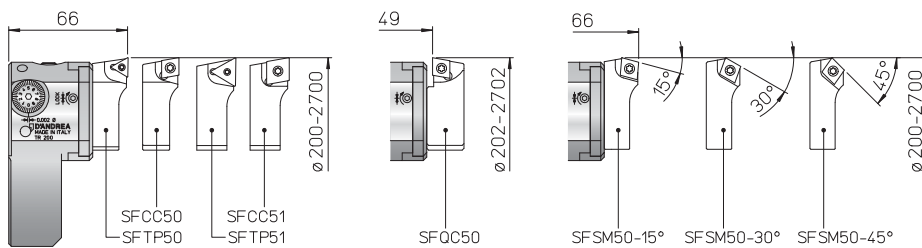


- MICROMETRIC HEAD TR 200
- MIKROMETRISCHER AUSDREHKOPF TR 200
- CABEZAL MICROMÉTRICO TR 200
- TÊTE MICROMÉTRIQUE TR 200
- TESTINA MICROMETRICA TR 200

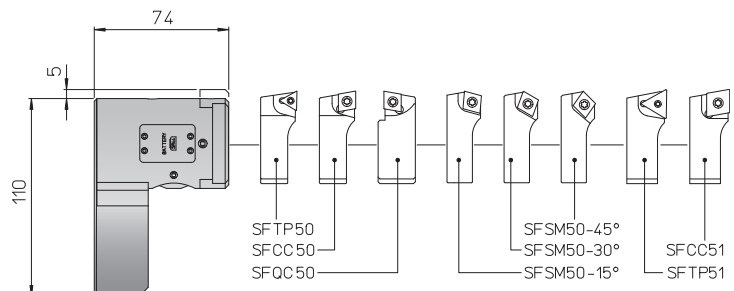
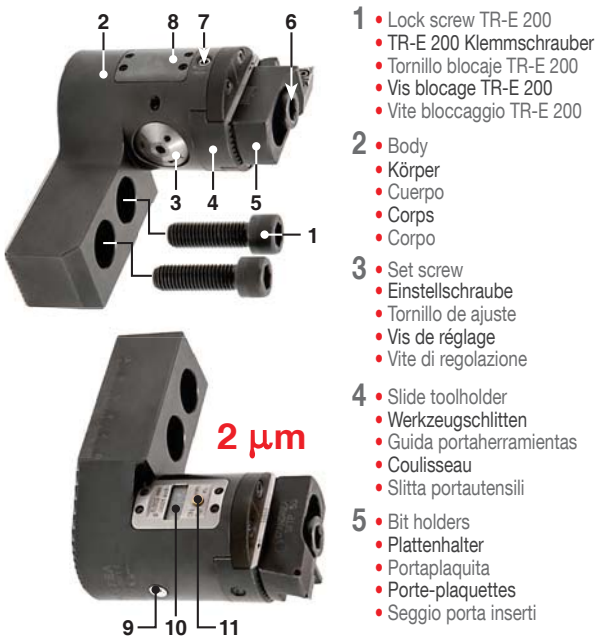
### TR 200



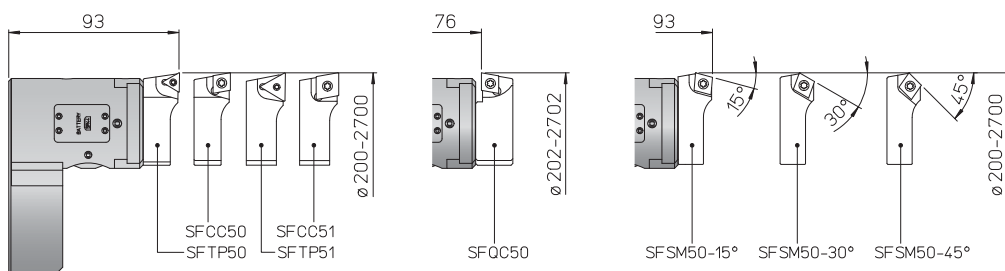
REF.	CODE	Kg.
TR 200	455020002000	1.3



### TR-ELETTRA 200



REF.	CODE	Kg.
TR-ELETTRA 200	455220002000	1.7



119



127

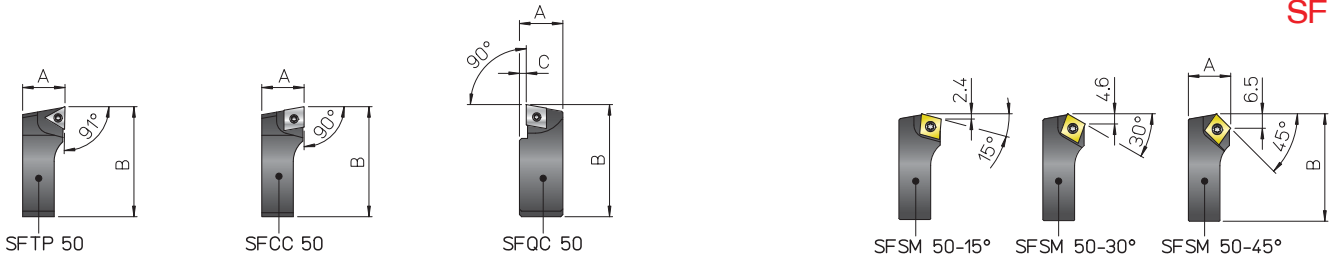


116



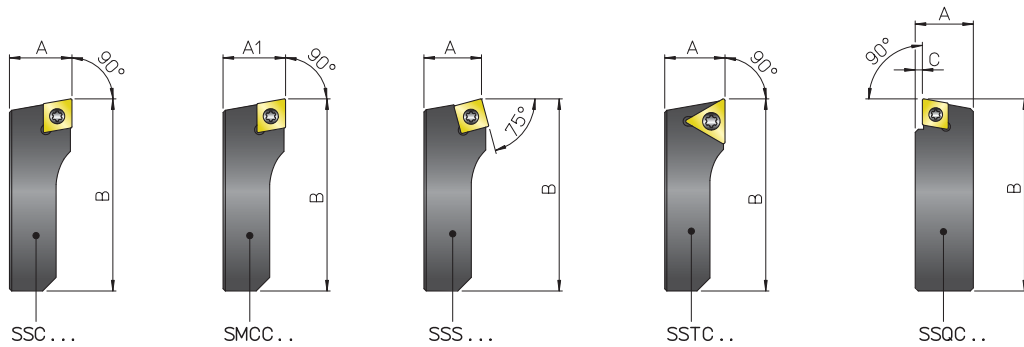
- MICROMETRIC HEAD TR-ELETTRA 200
- MIKROMETRISCHER AUSDREHKOPF TR-ELETTRA 200
- CABEZAL MICROMÉTRICO TR-ELETTRA 200
- TÊTE MICROMÉTRIQUE TR-ELETTRA 200
- TESTINA MICROMETRICA TR-ELETTRA 200

## SF



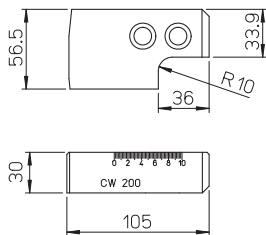
REF.	CODE	A	B	C	△	□	⊥	⌘	Kg.
SFTP 50	470500550001	19	52	-	TPGX 1103..	-	CS 300890T	TORX T08	0.08
SFTP 51	470500550003	21	52	-	TCMT 16T3..	-	TS 4	TORX T15	0.09
SFCC 50	470500550002	19	52	-	-	CCGT 09T3..	TS 4	TORX T15	0.08
SFCC 51	470500550004	21	52	-	-	CCMT 1204..	TS 5	TORX T25	0.09
SFQC 50	470500550062	20.5	53	3	-	CCMT 09T3..	TS 4	TORXT15	0.1
SF5M 50-15°	470500550011	19	50.5	-	-	CCMT 09T3..	TS 4	TORXT15	0.07
SF5M 50-30°	470500550013								
SF5M 50-45°	470500550015								

## SS-SM



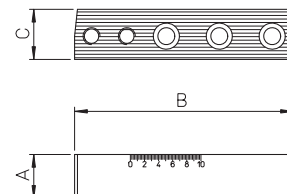
REF.	CODE	A	A1	B	C	□	□	△	⊥	⌘	Kg.
SSCC 90	470500590201	32	-	130	-	CCMT 1204..	-	-	TS 5	TORX T25	0.7
SSCN 95	470500595201	40	-	130	-	CNM. 1906..	-	-	p.126		0.9
SMCC 90	470500590203	-	31.7	130	-	CCMT 1204..	-	-	TS 5	TORX T25	0.7
SSSC 90	470500590202	32	-	130	-	-	SCMT 1204..	-	TS 5	TORX T25	0.7
SSSN 95	470500595202	40	-	130	-	-	SNM . 1906..	-	p.126		0.9
SSTC 90	470500590206	32	-	130	-	TCMT 2204..	-	-	TS 5	TORX T25	0.7
SSQC 90	470500590261	31.5	-	122	3.5	CCMT 1204..	-	-	TS 5	TORX T25	0.8

## CW



REF.	CODE	Kg.
CW 200	392011010501	1.3

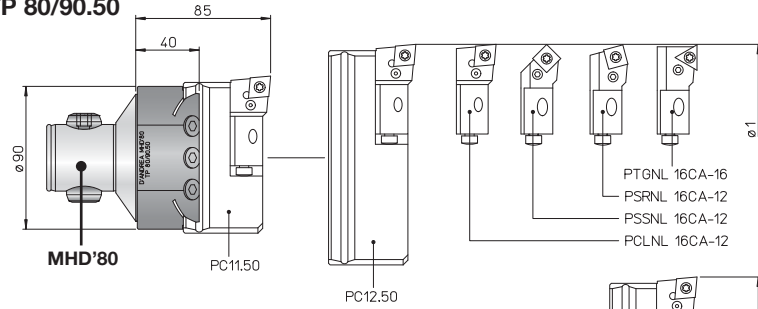
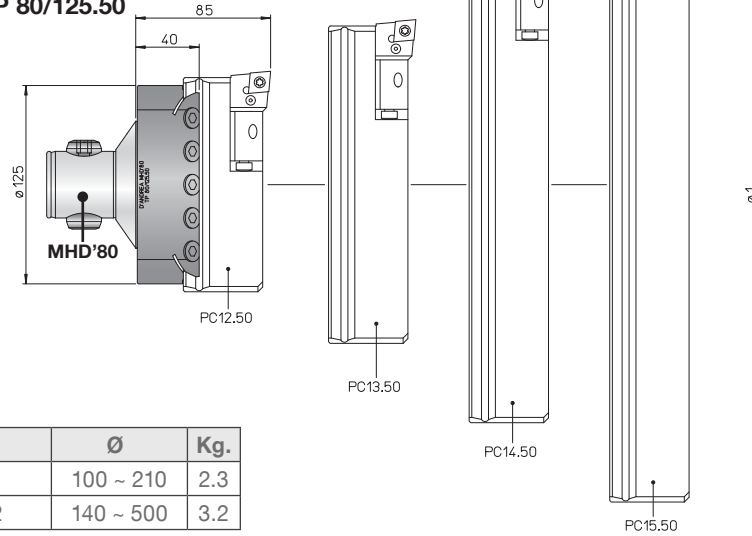
## PRL



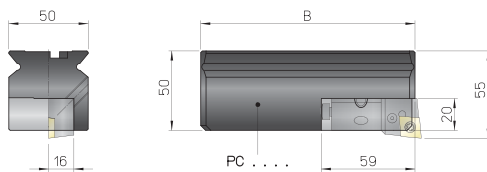
REF.	CODE	A	B	C	Kg.
PRL 100	392011015501	31	155	33.5	1.1
PRL 300	392011030001	41	255	35.5	2.8



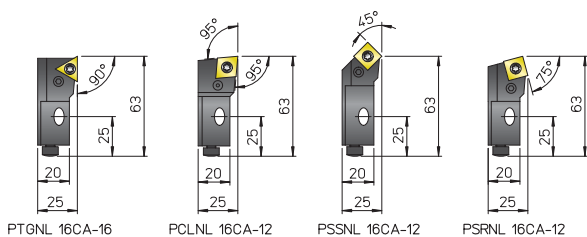
- TOOLHOLDERS
- WERKZEUGHALTER
- PORTAHERRAMIENTAS
- PORTE-OUTILS
- PORTAUTENSILI


**TP 80/90.50**

**TP 80/125.50**


REF.	CODE	Ø	Kg.
TP 80/90.50	460408050001	100 ~ 210	2.3
TP 80/125.50	460408050002	140 ~ 500	3.2

**PC**


REF.	CODE	B	Ø 1 TP80/90.50	Ø 1 TP80/125.50	Kg.
PC 11.50	433050160950	95	100 ~ 140	-	1.3
PC 12.50	433050161350	135	140 ~ 210	140 ~ 210	2
PC 13.50	433050162000	200	-	210 ~ 310	3.2
PC 14.50	433050163000	300	-	310 ~ 410	4.8
PC 15.50	433050164000	400	-	410 ~ 500	6.3

**16CA ISO 5611**


REF.	CODE	△
PTGNL 16CA-16	483010161001	TNM. 1604..
PCLNL 16CA-12	483010161002	CNM. 1204..
PSSNL 16CA-12	483010161003	SNM. 1204..
PSRNL 16CA-12	483010161004	

• On request • Auf Anfrage • A petición • Sur demande • Fornibili su richiesta

120



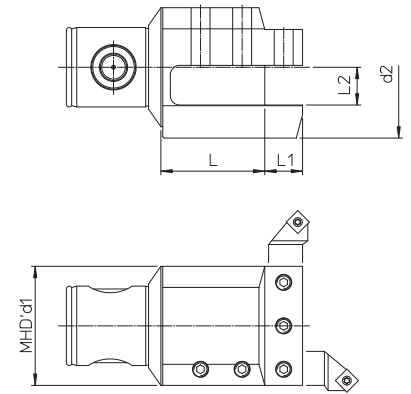
116



- TOOLHOLDERS
- WERKZEUGHALTER
- PORTAHERRAMIENTAS
- PORTE-OUTILS
- PORTAUTENSILI

TU

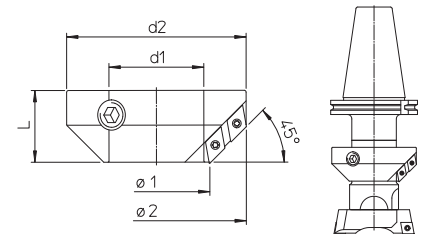
89



REF.	CODE	MHD' d1	d2	L	L1	L2	Kg.
TU 50/60.16	460505016001	50	60	44	16	16	1.2
TU 63/75.20	460506320001	63	75	55	20	20	2.4
TU 80/95.25	460508025001	80	95	65	25	25	3.6
TU 110/110.32	460511032001	110	130	78	32	32	11.2

- CHAMFERING TOOLS
- FASRINGE
- HERRAMIENTAS PARA ACHAFLANAR
- OUTIL À CHANFREINER
- ANELLO PER SMUSSI

AS.. 45°



REF.	CODE	Ø1	d1	d2	L				Kg.
AS 16.45	655601600130	18 ~ 28	16	28	13	DCMT 0702..	TS 25	TORX T08	0.035
AS 20.45	655602000150	23 ~ 32	20	32	15				0.045
AS 25.45	655602500180	28 ~ 43	25	43	18				0.1
AS 32.45	655603200220	35 ~ 54	32	54	22				0.2
AS 40.45	655604000300	46 ~ 72	40	72	30	DCMT 11T3..	TS 4	TORX T15	0.5
AS 50.45	655605000380	56 ~ 95	50	95	38				1.1
AS 63.45	655606300460	75 ~ 125	63	125	46	DCMT 1504..	TS 5	TORX 25	2.3
AS 80.45	655608000580	95 ~ 165	80	165	58				5.2

120



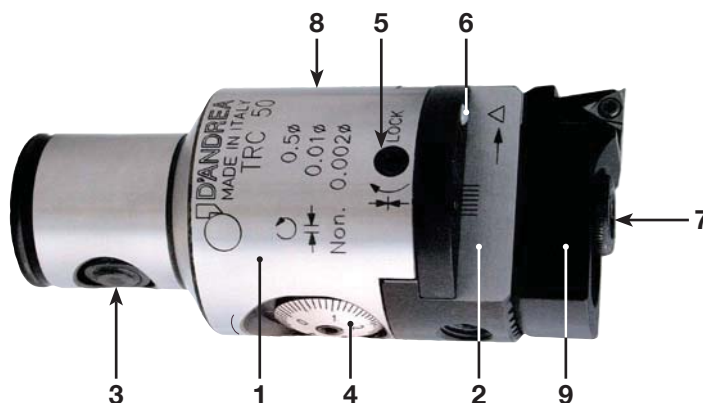


# D'ANDREA

## MODULHARD'ANDREA

90

- 1 • Body  
• Körper  
• Cuerpo  
• Corps  
• Corpo
- 2 • Slide toolholder  
• Werkzeugschlitten  
• Guía portaherramientas  
• Coulisseau  
• Slitta portautensili
- 3 • Expanding radial pin  
• Spreizbolzen  
• Perno radial expansible  
• Tige radiale expansible  
• Perno radiale espandibile
- 4 • Vernier scale  
• Nonius  
• Nonio  
• Vernier  
• Nonio
- 5 • Slide clamp screw  
• Schlittenklemmschraube  
• Tornillo bloqueo guía  
• Vis blocage coulisseau  
• Vite bloccaggio slitta
- 6 • Coolant outlet  
• Kühlmittelaustritt  
• Agujero salida refrigerante  
• Sortie du liquide d'arrosage  
• Uscita refrigerante



- 7 • Tools clamp screws  
• Werkzeugklemmschrauben  
• Tornillo bloqueo herramienta  
• Vis blocage outil  
• Viti bloccaggio utensile
- 8 • Oiler  
• Schmiernippel  
• Engrasador  
• Graisseur  
• Oliatore
- 9 • Bit holder  
• Plattenhalter  
• Portaplaquita  
• Porte-plaquettes  
• Seggio portainseriti

**10 μm**  
nonio  
vernier 2 μm



**GB FEATURES.** High precision work to IT6 tolerance, with excellent surface finish, is achieved using TRC boring heads. These are very sensitive and radial correction of 5 micron can be effected directly on the machine and easily read on the vernier scale.

**D MERKMALE.** Die TRC Köpfe ermöglichen Bearbeitungen mit hoher Präzision und Toleranzen mit Grad IT6 bei hochwertiger Oberflächengüte. Sie besitzen eine Feinverstellung mit einer Genauigkeit von radial 5 μm, wobei das Maß auf der Skala abgelesen und auch direkt an der Maschine eingestellt werden kann.

**E CARACTERÍSTICAS.** Los cabezales TRC permiten realizar operaciones de alta precisión con tolerancias de grado IT6 con un extraordinario acabado de la superficie. Tienen una sensibilidad de ajuste de 5 micras en radio, de fácil lectura en el nonio y corregibles directamente sobre la máquina.

**F CARACTÉRISTIQUES.** Les têtes TRC permettent des usinages de haute précision avec des tolérances de degré IT6 comprenant un excellent finissage superficiel. Elles ont une sensibilité de réglage de 5 microns sur le rayon, facilement lisible sur le vernier et exécutable également dans la machine.

**I CARATTERISTICHE.** Le testine TRC consentono lavorazioni di alta precisione con tolleranze di grado IT6 con ottima finitura superficiale. Hanno una sensibilità di regolazione di 5 micron sul raggio, facilmente leggibile sul nonio ed eseguibile anche in macchina.



TRC 14  
Ø 14.5 ~ 18



TRC 16  
Ø 18 ~ 24



TRC 20  
Ø 22 ~ 30



TRC 25  
Ø 28 ~ 40



TRC 32  
Ø 35.5 ~ 53.5



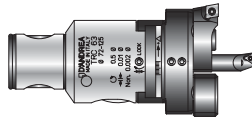
TRC 40  
Ø 48 ~ 66



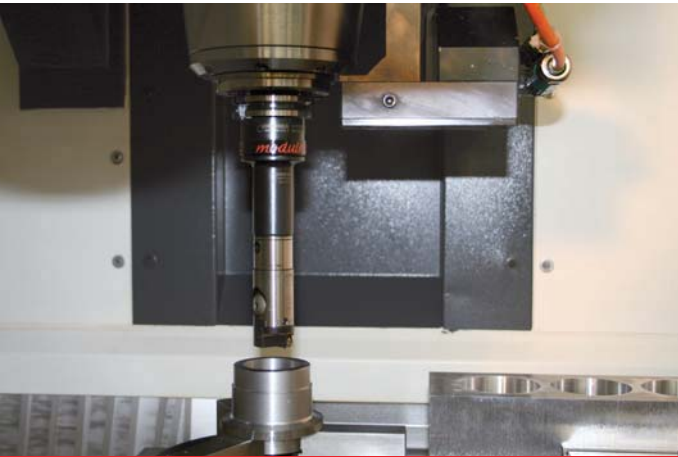
TRC 50  
Ø 2.5 ~ 110



TRC 63  
Ø 6 ~ 125

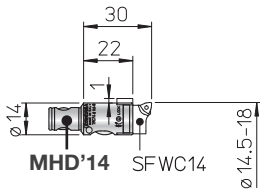
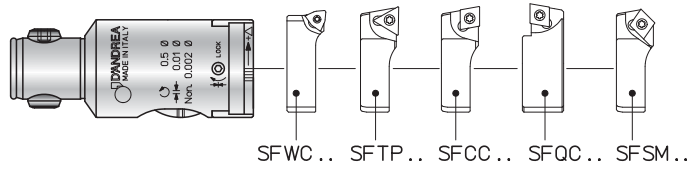


TRC 80  
Ø 6 ~ 200

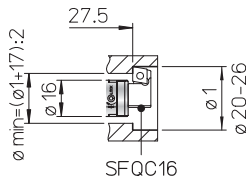
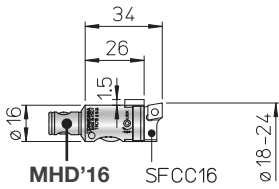


# D'ANDREA

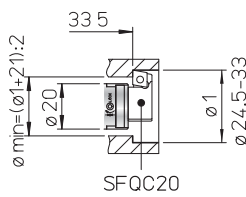
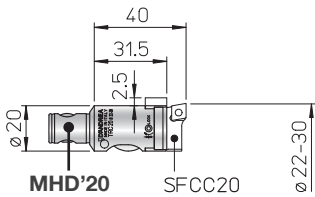
## MODULHARD'ANDREA



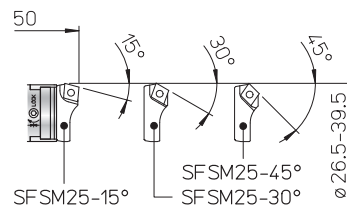
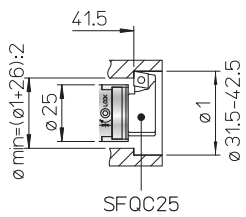
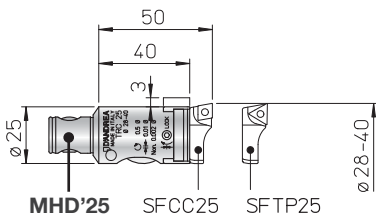
**TRC 14**  
 Ø 14.5 ~ 18



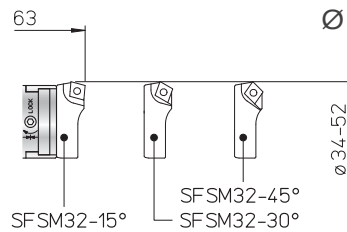
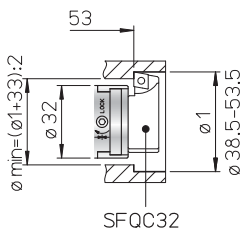
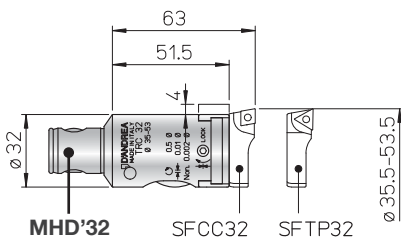
**TRC 16**  
 Ø 18 ~ 24



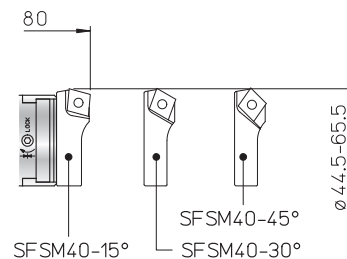
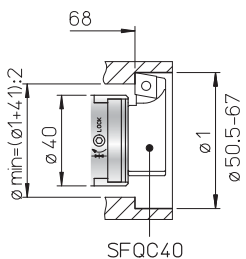
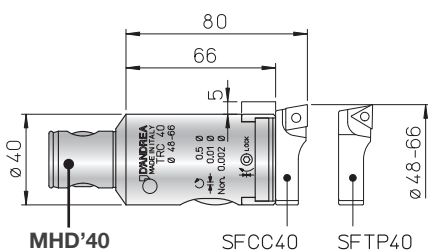
**TRC 20**  
 Ø 22 ~ 30



**TRC 25**  
 Ø 28 ~ 40



**TRC 32**  
 Ø 35.5 ~ 53.5



**TRC 40**  
 Ø 48 ~ 66



• TESTAROSSA

TRC

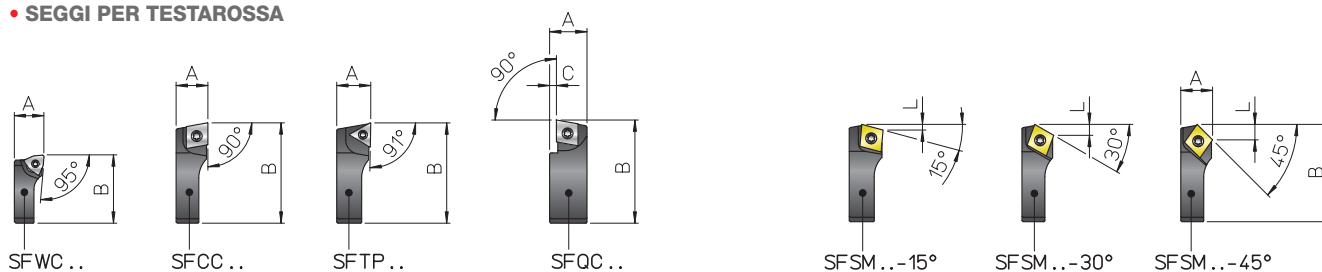


10 μm  
nonio  
vernier 2 μm

REF.	CODE	Kg.
TRC 14	455011400301	0.02
TRC 16	455011600341	0.05
TRC 20	455012000401	0.1
TRC 25	455012500501	0.2
TRC 32	455013200631	0.35
TRC 40	455014000801	0.7

- BIT-HOLDERS FOR TESTAROSSA
- PLATTENHALTER FÜR TESTAROSSA
- PORTA-PLAQUITAS PARA TESTAROSSA
- PORTE-PLAQUETTES POUR TESTAROSSA
- SEGGI PER TESTAROSSA

SF



REF.	CODE	A	B	C	L	⊖	⊖	⊖	⊖	⊖	Kg.
SFWC 14	470500514002	8	14	-	-	WCGT 0201..	-	-	TS 211	TORX T06	0.003
SFCC 16	470500516002	8	17	-	-	-	-	-	-	-	0.003
SFCC 20	470500520002	8.5	21	-	-	-	CCGT 0602..	-	TS 25	TORX T08	0.005
SFCC 25	470500525002	10	26.5	-	-	-	-	-	-	-	0.01
SFCC 32	470500532002	11.5	34.5	-	-	-	-	-	-	-	0.02
SFCC 40	470500540002	14	44	-	-	-	CCGT 09T3..	-	TS 4	TORX T15	0.04
SFTP 25	470500525001	10	26.5	-	-	-	-	TPGX 0902..	CS 250T	TORX T08	0.01
SFTP 32	470500532001	11.5	34.5	-	-	-	-	-	-	-	0.02
SFTP 40	470500540001	14	44	-	-	-	-	TPGX 1103..	CS 300890T	-	0.04
SFQC 16	470500516062	10	18	2	-	-	-	-	-	-	0.005
SFQC 20	470500520062	10.5	22.5	2	-	-	-	-	-	-	0.008
SFQC 25	470500525062	12	28.5	2.5	-	-	CCMT 0602..	-	TS 25	TORX T08	0.01
SFQC 32	470500532062	13.5	35.5	2.5	-	-	-	-	-	-	0.03
SFQC 40	470500540062	16.5	46	3	-	-	CCMT 09T3..	-	TS 4	TORXT15	0.06
SFSM 25-15°	470500525011	10	25.5	-	1.6	-	-	-	-	-	0.01
SFSM 25-30°	470500525013	10	25.5	-	3	-	-	-	-	-	0.01
SFSM 25-45°	470500525015	10	25.5	-	4.3	-	-	-	-	-	0.01
SFSM 32-15°	470500532011	11.5	33.5	-	1.6	-	CCMT 0602..	-	TS 25	TORX T08	0.02
SFSM 32-30°	470500532013	11.5	33.5	-	3	-	-	-	-	-	0.02
SFSM 32-45°	470500532015	11.5	33.5	-	4.3	-	-	-	-	-	0.02
SFSM 40-15°	470500540011	14	42.5	-	2.4	-	-	-	-	-	0.03
SFSM 40-30°	470500540013	14	42.5	-	4.6	-	CCMT 09T3..	-	TS 4	TORXT15	0.03
SFSM 40-45°	470500540015	14	42.5	-	6.5	-	-	-	-	-	0.03

116

120

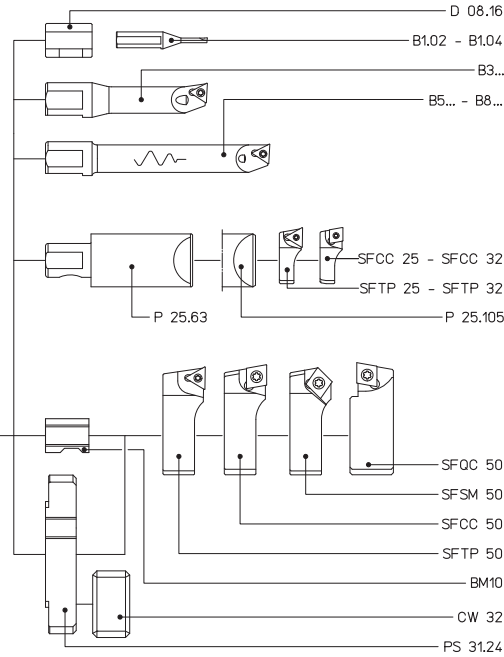
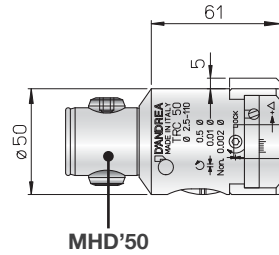
119



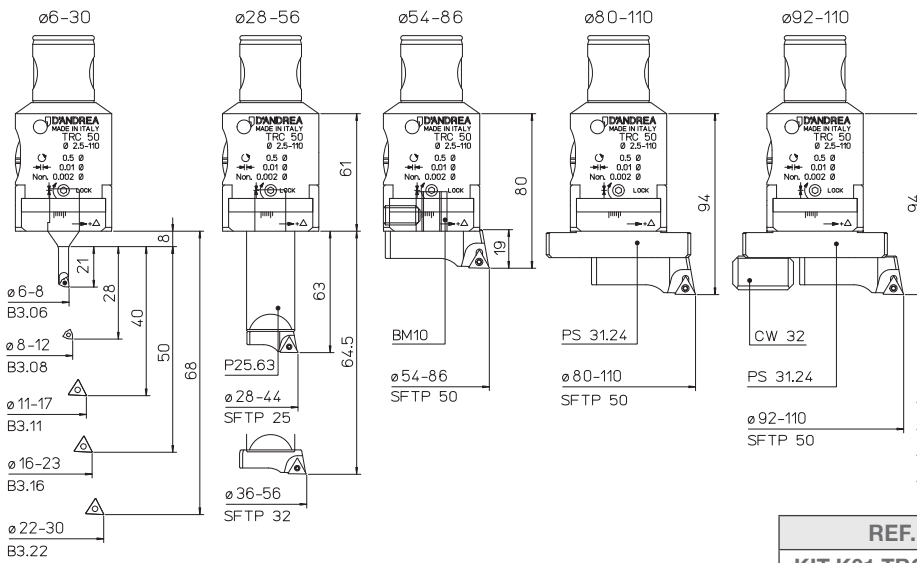
# D'ANDREA MODULHARD'ANDREA



**10 µm**  
nonio  
vernier **2 µm**



REF.	CODE	Kg.
TRC 50	455015000801	1

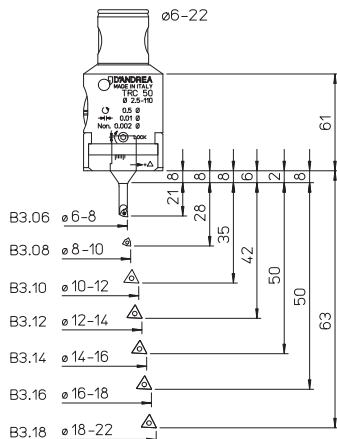


**KIT K01**  
Ø 6 ~ 110



- 1 TRC 50
- 1 CW 32
- 1 B3.16
- 1 SFTP50
- 1 P25.63
- 1 B3.06
- 1 B3.22
- 5 TPGX 090202L DC100
- 1 BM10
- 1 B3.08
- 1 SFTP25
- 1 TPGX 110302L DC100
- 1 PS 31.24
- 1 B3.11
- 1 SFTP32
- 2 WCGT 020102L DC100

REF.	CODE	Ø
KIT K01 TRC 50	655015010502	6 ~ 110



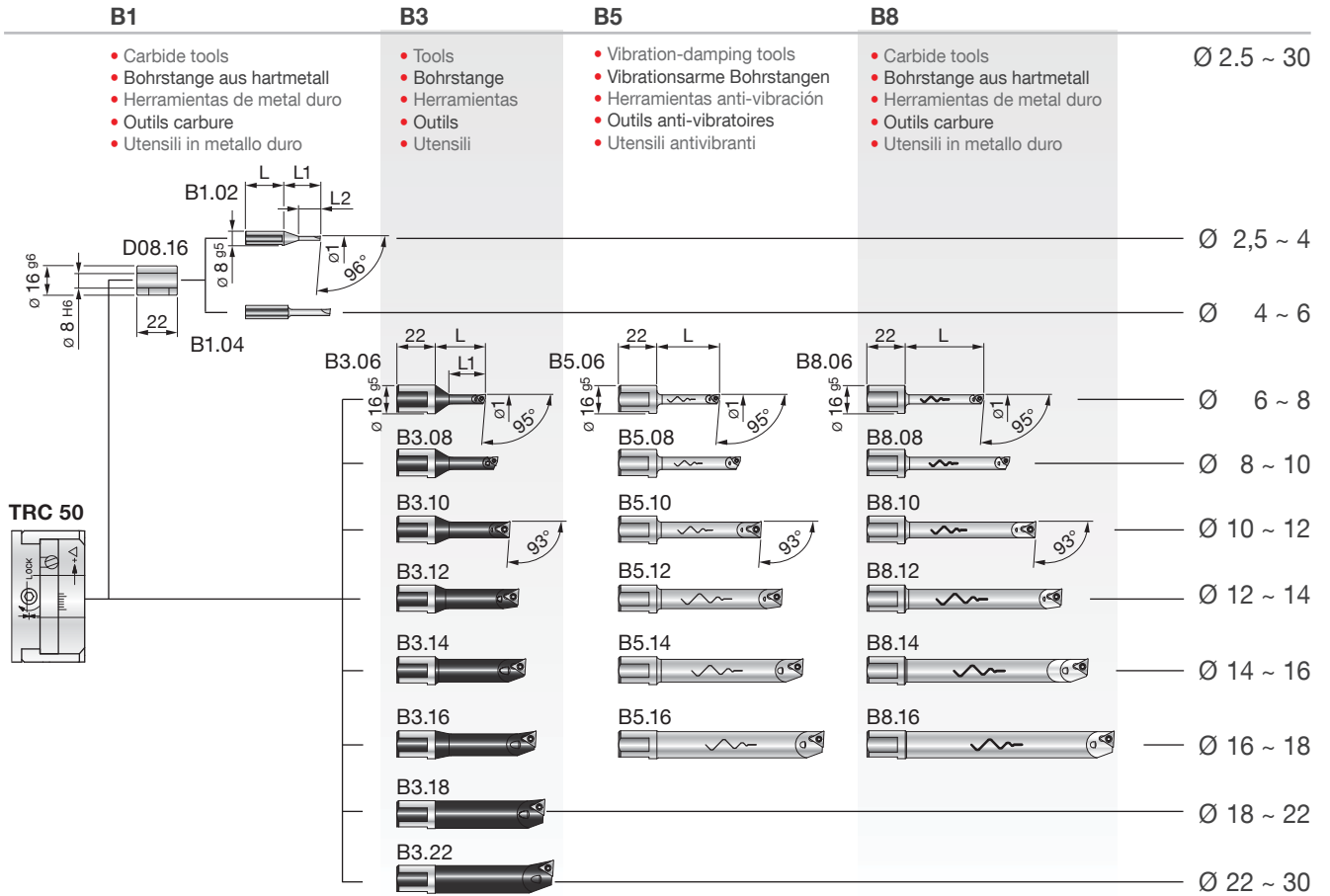
**KIT K00**  
Ø 6 ~ 22



- 1 TRC50
- 1 B3.10
- 1 B3.16
- 5 TPGX 090202L DC100
- 1 B3.06
- 1 B3.12
- 1 B3.18
- 2 WCGT 020102L DC100
- 1 B3.08
- 1 B3.14

REF.	CODE	Ø
KIT K00 TRC 50	655015010500	6 ~ 22





REF.	CODE	Kg.
D08.16	200560116082	0.02

REF.	CODE	Ø1	L	L1	L2	Kg.
B1.02	572010502001	2.5 ~ 4	22	21	12.5	0.02
B1.04	572010504001	4 ~ 6	24	24	-	

REF.	CODE	Ø1	L	L1	⊖	⊖	⊖	⊖	Kg.
B3.06	572010506001	6 ~ 8	29	21	WCGT 0201..	-	TS 21	TORX T06	0.035
B3.08	572010508001	8 ~ 10	36	28			TS 211		0.04
B3.10	572010510001	10 ~ 12	43	35	-	TPGX 0902..	CS 250 T	TORX T08	0.05
B3.11	572010511001	11 ~ 13	48	40					0.055
B3.12	572010512001	12 ~ 14	42	42					0.06
B3.14	572010514001	14 ~ 16	52	50					0.07
B3.16	572010516001	16 ~ 18	58	-	-	-	-	-	0.1
B3.18	572010518001	18 ~ 22	63	-					
B3.22	572010522001	22 ~ 30	68	-					

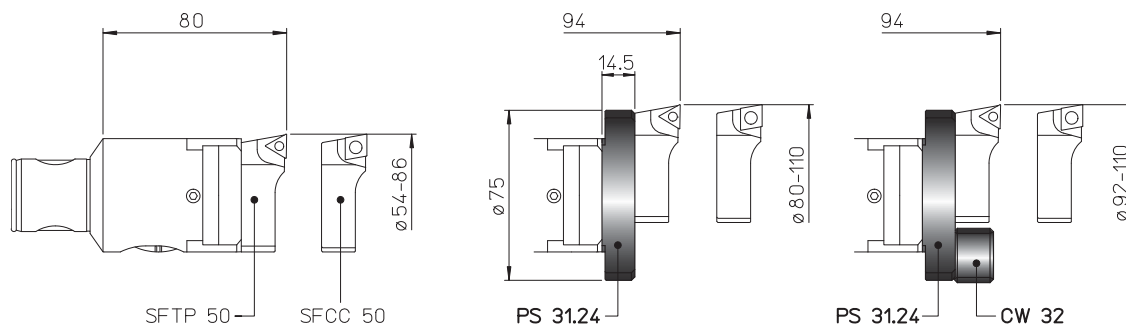
B5.06	572010506105	6 ~ 8	36	-	WCGT 0201..	-	TS 21	TORX T06	0.075
B5.08	572010508105	8 ~ 10	48				TS 211		0.09
B5.10	572010510105	10 ~ 12	60	-	TPGX 0902..	CS 250 T	TORX T08	0.1	
B5.12	572010512105	12 ~ 14	72					0.2	
B5.14	572010514105	14 ~ 16	84					0.3	
B5.16	572010516105	16 ~ 18	96					0.3	

B8.06	572010506108	6 ~ 8	45	-	WCGT 0201..	-	TS 21	TORX T06	0.065
B8.08	572010508108	8 ~ 10	60				TS 211		0.08
B8.10	572010510108	10 ~ 12	75	-	TPGX 0902..	CS 250 T	TORX T08	0.1	
B8.12	572010512108	12 ~ 14	90					0.2	
B8.14	572010514108	14 ~ 16	105					0.3	
B8.16	572010516108	16 ~ 18	120					0.3	

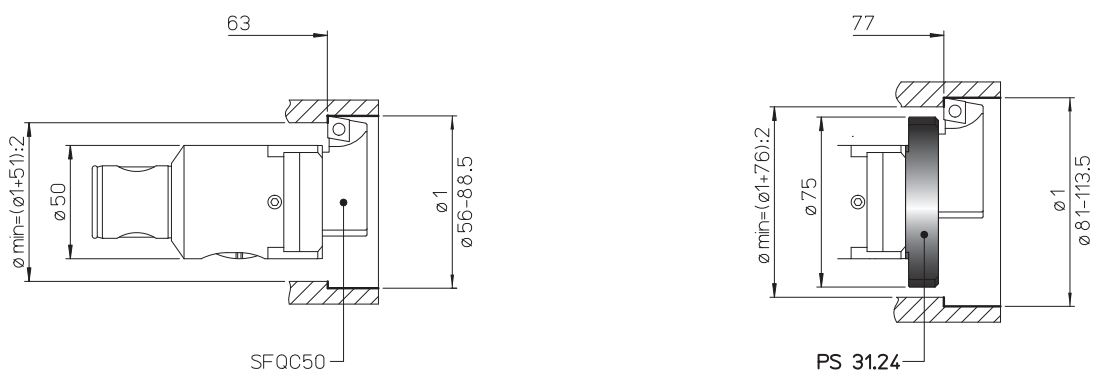


- TOOLHOLDERS FOR TESTAROSSA
- WERKZEUGE FÜR TESTAROSSA
- PORTAHERRAMIENTAS PARA TESTAROSSA
- PORTE-OUTILS POUR TESTAROSSA
- PORTAUTENSILI PER TESTAROSSA

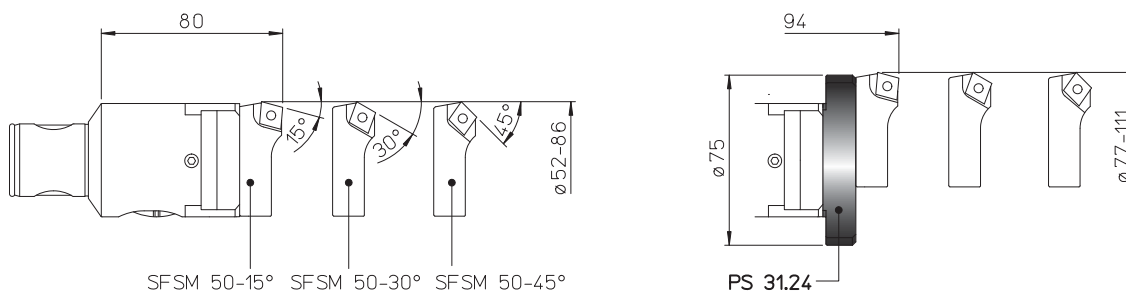
**PS 31**  
**CW 32**  
Ø 54 ~ 110



**PS 31**  
Ø 56 ~ 113.5



**PS 31**  
Ø 52 ~ 111

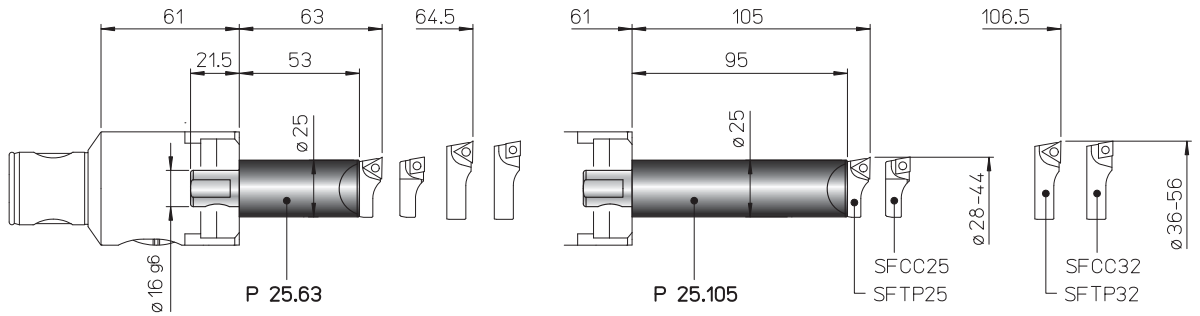


REF.	CODE	Kg.
PS 31.24 TR..50	433024140751	0.19
CW 32	392011003201	0.07



- TOOLHOLDERS FOR TESTAROSSA
- WERKZEUGE FÜR TESTAROSSA
- PORTAHERRAMIENTAS PARA TESTAROSSA
- PORTE-OUTILS POUR TESTAROSSA
- PORTAUTENSILI PER TESTAROSSA

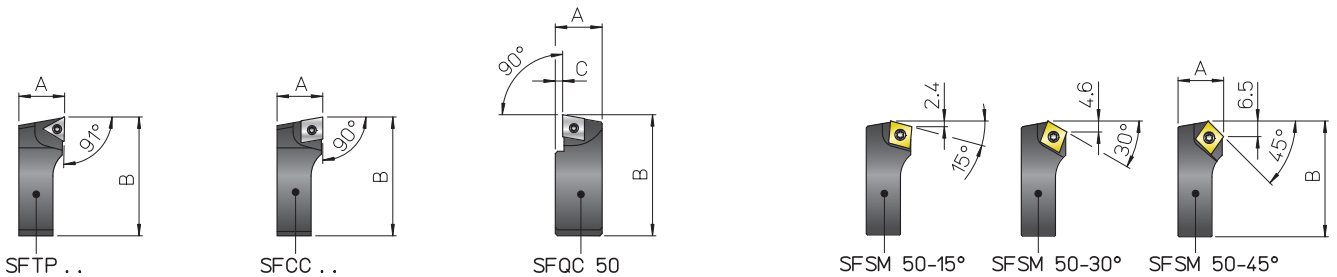
P 25  
Ø 28 ~ 56



REF.	CODE	Kg.
P25.63 TR...	435116250631	0.5
P25.105 TR...	435116251051	0.8

- BIT-HOLDERS FOR TESTAROSSA
- PLATTENHALTER FÜR TESTAROSSA
- PORTA-PLAQUITAS PARA TESTAROSSA
- PORTE-PLAQUETTES POUR TESTAROSSA
- SEGGI PER TESTAROSSA

SF



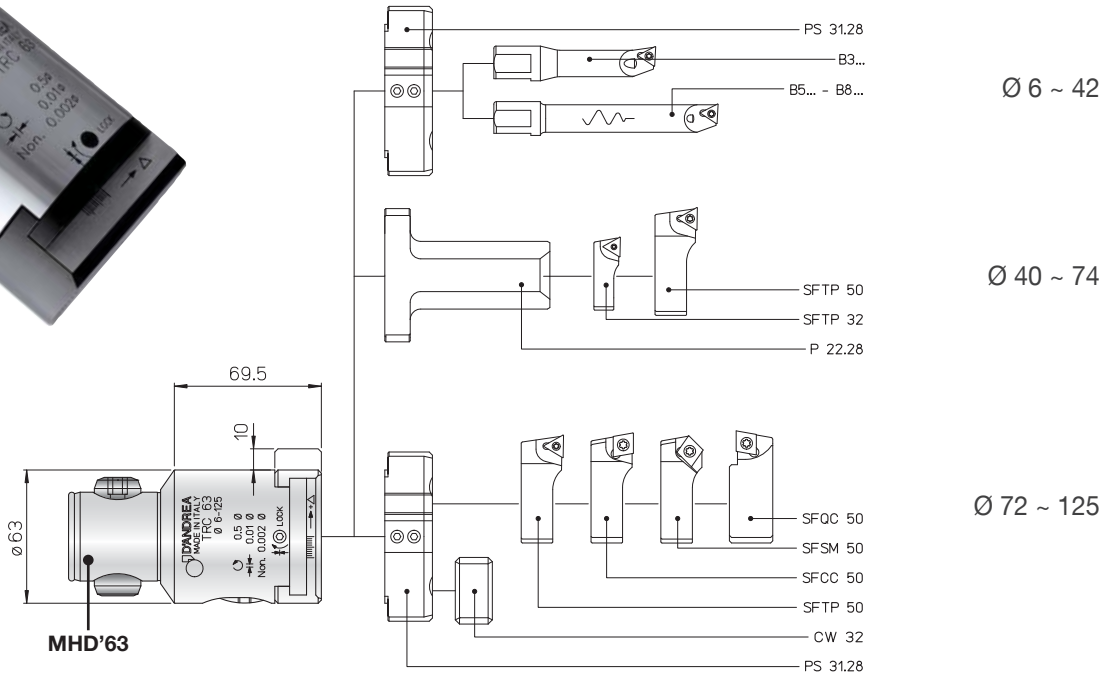
REF.	CODE	A	B	C	△	□	⌋	⌋	Kg.
SFTP 25	470500525001	10	26.5	-	TPGX 0902..	-	CS 250T	TORX T08	0.01
SFTP 32	470500532001	11.5	34.5	-	-	-	0.02		
SFTP 50	470500550001	19	52	-	TPGX 1103..	-	CS 300890T		0.08
SFCC 25	470500525002	10	26.5	-	-	CCGT 0602..	TS 25	TORX T08	0.01
SFCC 32	470500532002	11.5	34.5	-	-	-	-	TORX T08	0.02
SFCC 50	470500550002	19	52	-	-	CCGT 09T3..	TS 4	TORX T15	0.08
SFQC 50	470500550062	20.5	53	3	-	CCMT 09T3..	TS 4	TORXT15	0.1
SFSM 50-15°	470500550011	19	50.5	-	-	CCMT 09T3..	TS 4	TORXT15	0.07
SFSM 50-30°	470500550013								
SFSM 50-45°	470500550015								

# D'ANDREA

## MODULHARD'ANDREA

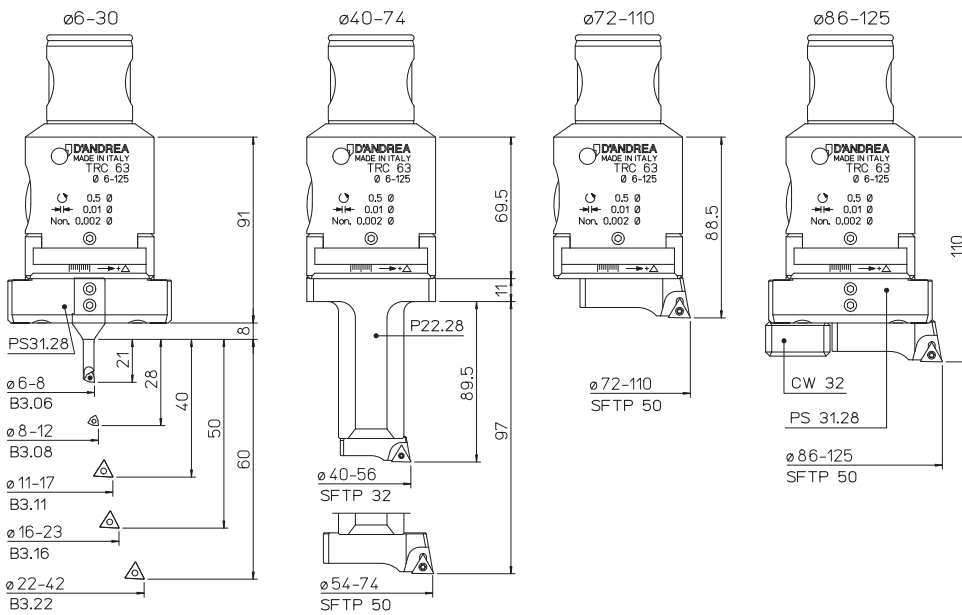


**10 μm**  
nonio  
vernier **2 μm**



REF.	CODE	Kg.
TRC 63	455016301001	2

**KIT K01**  
Ø 6 ~ 125



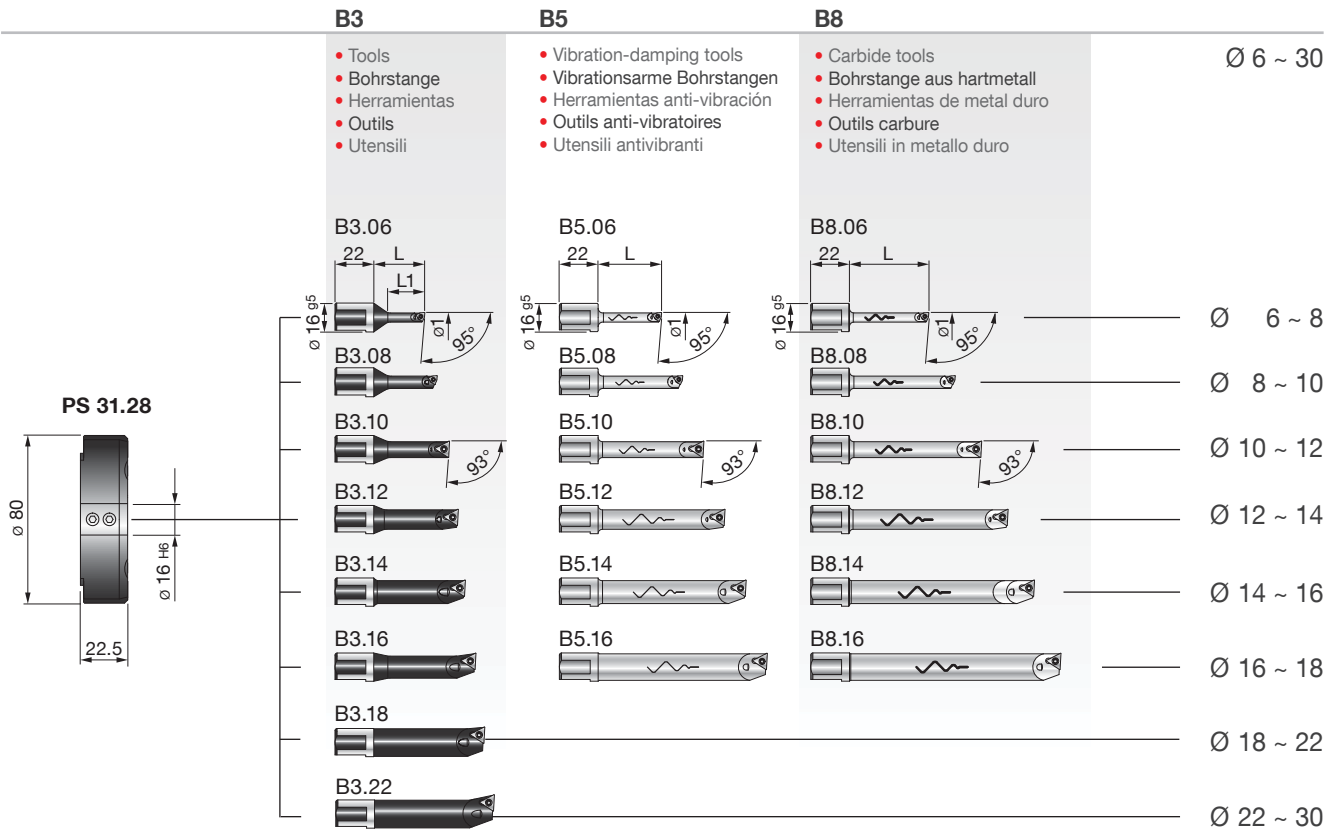
- 1 TRC 63
- 1 PS31.28
- 1 CW 32
- 1 P22.28
- 1 B3.06
- 5 TPGX 090202L DC100
- 1 TPGX 110302L DC100
- 2 WCGT 020102L DC100
- 1 B3.08
- 1 B3.11
- 1 B3.16
- 1 B3.22
- 1 SFTP32
- 1 SFTP50

REF.	CODE	Ø
KIT K01 TRC 63	655016310632	6 ~ 125

119 120 116 241

INFO





REF.	CODE	Kg.
PS 31.28 TRC 63	433028220801	0.3

REF.	CODE	Ø1	L	L1	⚠	⚠	🔩	🔩	Kg.
B3.06	572010506001	6 ~ 8	29	21	WCGT 0201..	-	TS 21	TORX T06	0.035
B3.08	572010508001	8 ~ 10	36	28			TS 211		0.04
B3.10	572010510001	10 ~ 12	43	35					0.05
B3.11	572010511001	11 ~ 13	48	40				0.055	
B3.12	572010512001	12 ~ 14	48	42				0.06	
B3.14	572010514001	14 ~ 16	52	50	-	TPGX 0902..	CS 250 T	TORX T08	0.07
B3.16	572010516001	16 ~ 18	58						
B3.18	572010518001	18 ~ 22	63	-					0.1
B3.22	572010522001	22 ~ 30	68	-					

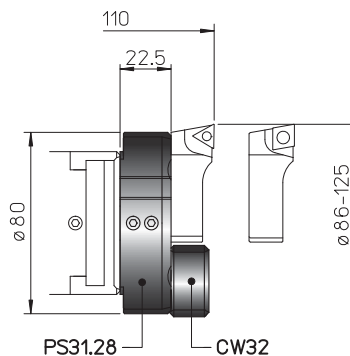
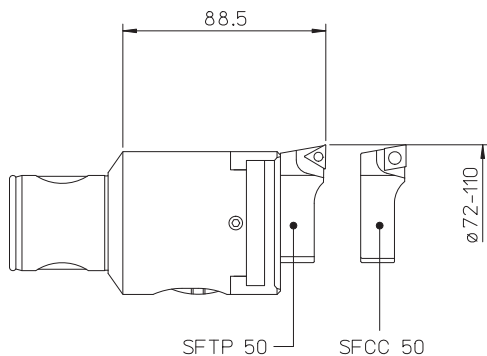
B5.06	572010506105	6 ~ 8	36	-	WCGT 0201..	-	TS 21	TORX T06	0.075
B5.08	572010508105	8 ~ 10	48				TS 211		0.09
B5.10	572010510105	10 ~ 12	60						
B5.12	572010512105	12 ~ 14	72		-	TPGX 0902..	CS 250 T	TORX T08	0.2
B5.14	572010514105	14 ~ 16	84						0.3
B5.16	572010516105	16 ~ 18	96						

B8.06	572010506108	6 ~ 8	45	-	WCGT 0201..	-	TS 21	TORX T06	0.065
B8.08	572010508108	8 ~ 10	60				TS 211		0.08
B8.10	572010510108	10 ~ 12	75						
B8.12	572010512108	12 ~ 14	90		-	TPGX 0902..	CS 250 T	TORX T08	0.2
B8.14	572010514108	14 ~ 16	105						0.3
B8.16	572010516108	16 ~ 18	120						

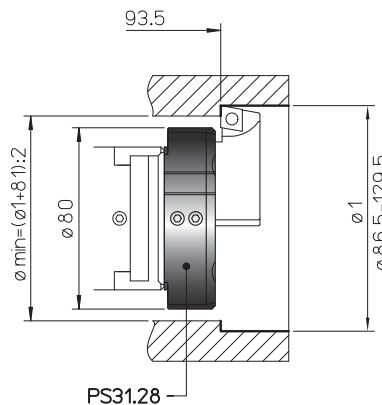
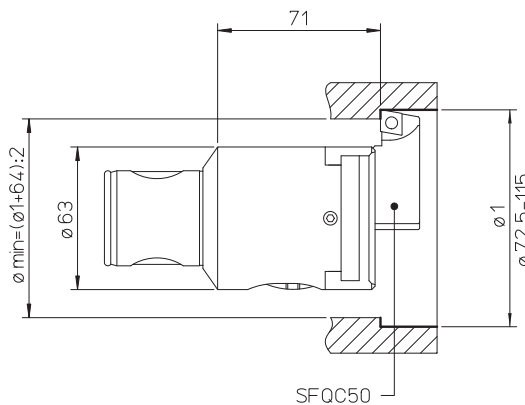


- TOOLHOLDERS FOR TESTAROSSA
- WERKZEUGE FÜR TESTAROSSA
- PORTAHERRAMIENTAS PARA TESTAROSSA
- PORTE-OUTILS POUR TESTAROSSA
- PORTAUTENSILI PER TESTAROSSA

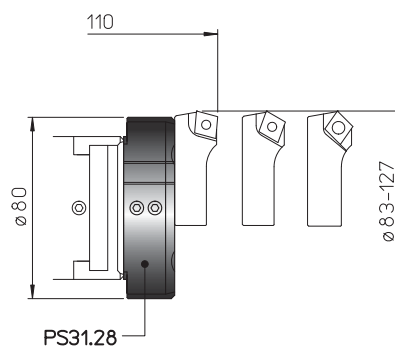
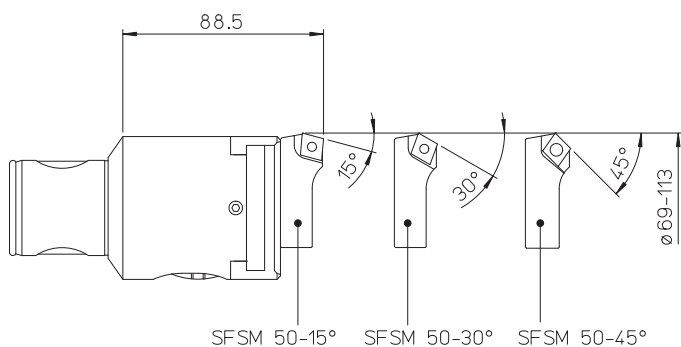
**PS 31**  
**CW 32**  
Ø 72~125



**PS 31**  
Ø 72.5 ~ 129.5



**PS 31**  
Ø 69 ~ 127

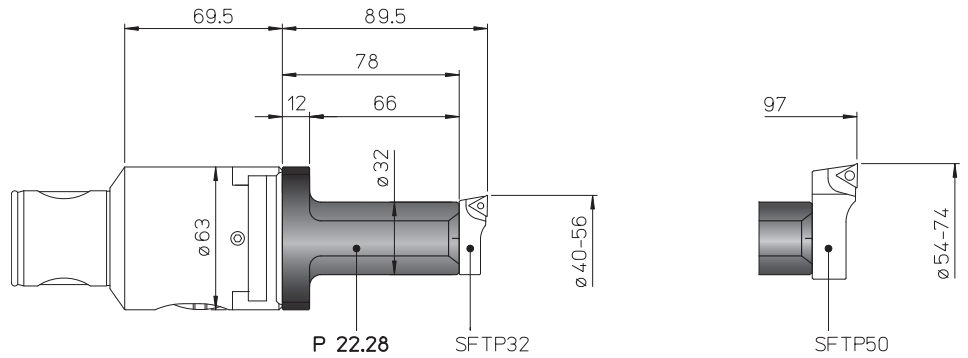


REF.	CODE	Kg.
PS 31.28 TRC 63	433028220801	0.3
CW 32	392011003201	0.07



- TOOLHOLDERS FOR TESTAROSSA
- WERKZEUGE FÜR TESTAROSSA
- PORTAHERRAMIENTAS PARA TESTAROSSA
- PORTE-OUTILS POUR TESTAROSSA
- PORTAUTENSILI PER TESTAROSSA

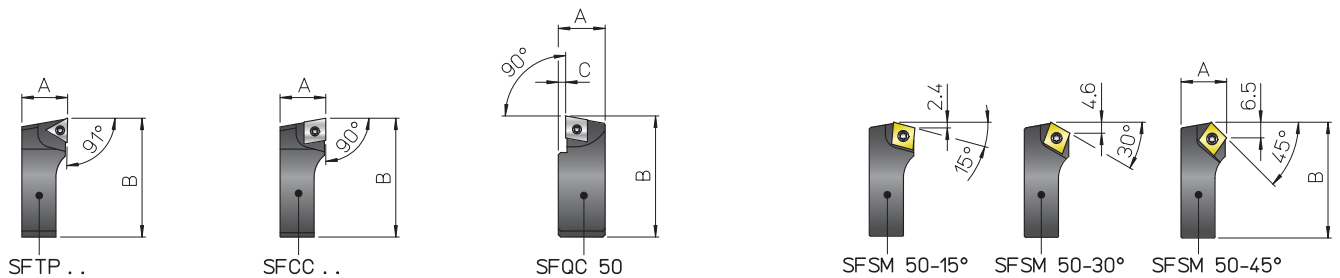
P 22  
Ø 40 ~ 74



REF.	CODE	Ø
P 22.28	433028220631	0.45

- BIT-HOLDERS FOR TESTAROSSA
- PLATTENHALTER FÜR TESTAROSSA
- PORTA-PLAQUITAS PARA TESTAROSSA
- PORTE-PLAQUETTES POUR TESTAROSSA
- SEGGI PER TESTAROSSA

SF



REF.	CODE	A	B	C	△	□	⊥	⌘	Kg.
SFTP 32	470500532001	11.5	34.5	-	TPGX 0902..	-	CS 250T	TORX T08	0.02
SFTP 50	470500550001	19	52	-	TPGX 1103..	-	CS 300890T		0.08
SFCC 50	470500550002	19	52	-	-	CCGT 09T3..	TS 4	TORX T15	0.08
SFQC 50	470500550062	20.5	53	3	-	CCMT 09T3..	TS 4	TORXT15	0.1
SFSM 50-15°	470500550011	19	50.5	-	-	CCMT 09T3..	TS 4	TORXT15	0.07
SFSM 50-30°	470500550013								
SFSM 50-45°	470500550015								

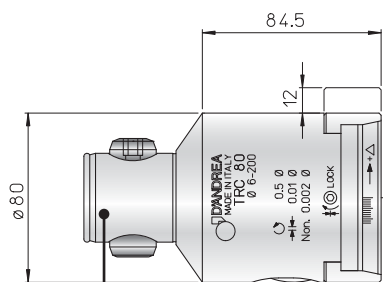


# D'ANDREA MODULHARD'ANDREA

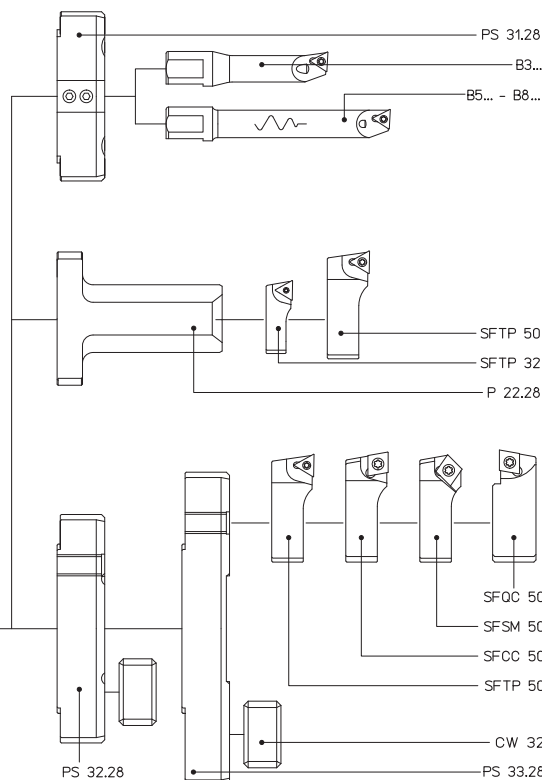
**TRC 80** Ø 6 ~ 200

• TESTAROSSA

**10 µm**  
nonio  
vernier **2 µm**



MHD'80



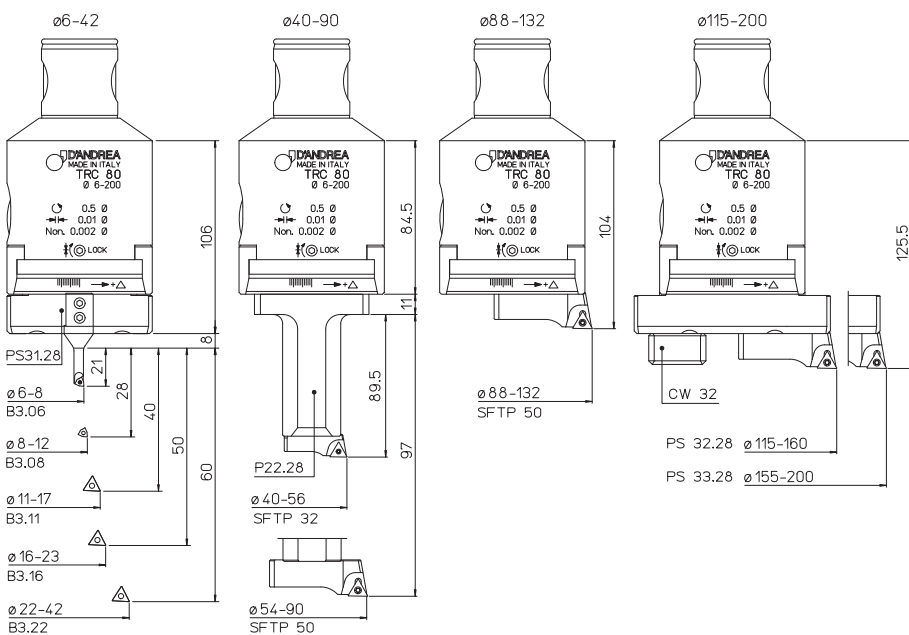
Ø 6 ~ 42

Ø 40 ~ 90

Ø 88 ~ 200

REF.	CODE	Kg.
TRC 80	455018001201	3.8

**KIT K01**  
Ø 6 ~ 200



- 1 TRC 80
- 1 PS31.28
- 1 PS32.28
- 1 PS33.28
- 1 CW 32
- 1 P22.28
- 5 TPGX 090202L DC100
- 1 TPGX 110302L DC100
- 2 WCGT 020102L DC100
- 1 B3.06
- 1 B3.08
- 1 B3.11
- 1 B3.16
- 1 B3.22
- 1 SFTP32
- 1 SFTP50

REF.	CODE	Ø
KIT K01 TRC 80	655018010802	6 ~ 200

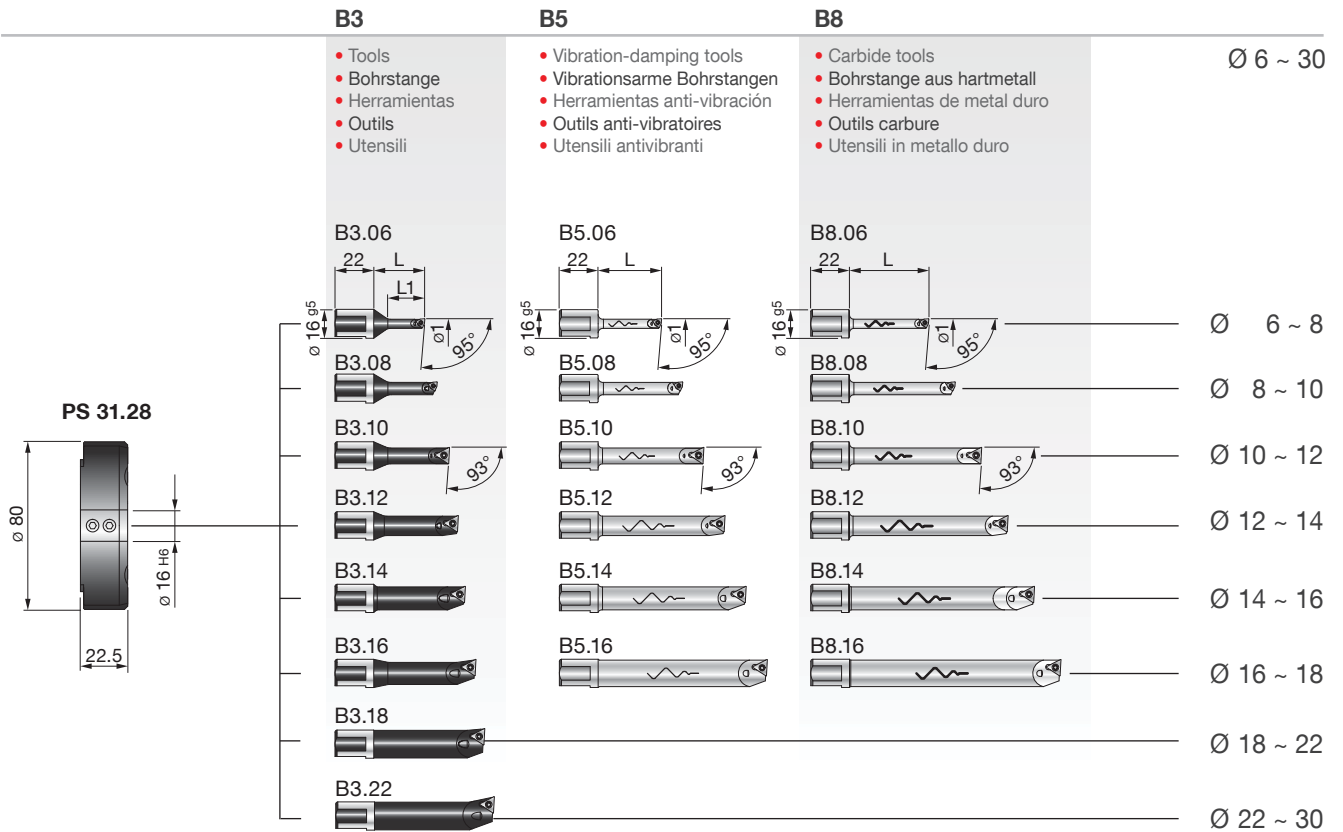
119 INFO

120

116

241





REF.	CODE	Kg.
PS 31.28 TRC 80	433028220801	0.3

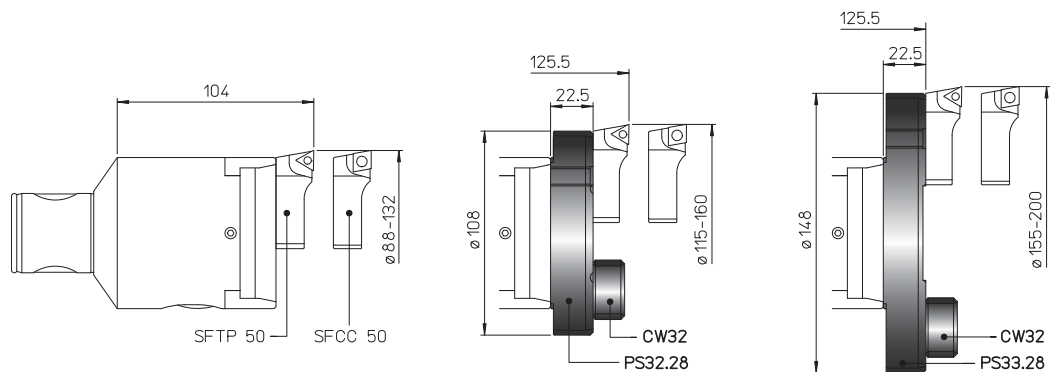
REF.	CODE	Ø1	L	L1	⚠	⚠	🔩	🔩	Kg.
B3.06	572010506001	6 ~ 8	29	21	WCGT 0201..	-	TS 21	TORX T06	0.035
B3.08	572010508001	8 ~ 10	36	28			TS 211		0.04
B3.10	572010510001	10 ~ 12	43	35	-	TPGX 0902..	CS 250 T	TORX T08	0.05
B3.11	572010511001	11 ~ 13	48	40					0.055
B3.12	572010512001	12 ~ 14	48	42	-	TPGX 0902..	CS 250 T	TORX T08	0.06
B3.14	572010514001	14 ~ 16	52	50					0.07
B3.16	572010516001	16 ~ 18	58	50	-	TPGX 0902..	CS 250 T	TORX T08	0.07
B3.18	572010518001	18 ~ 22	63	-					0.1
B3.22	572010522001	22 ~ 30	68	-	WCGT 0201..	-	TS 21	TORX T06	0.065
B5.06	572010506105	6 ~ 8	36	-			TS 211		0.08
B5.08	572010508105	8 ~ 10	48	-	-	TPGX 0902..	CS 250 T	TORX T08	0.09
B5.10	572010510105	10 ~ 12	60	-					0.1
B5.12	572010512105	12 ~ 14	72	-	-	TPGX 0902..	CS 250 T	TORX T08	0.2
B5.14	572010514105	14 ~ 16	84	-					0.3
B5.16	572010516105	16 ~ 18	96	-	WCGT 0201..	-	TS 21	TORX T06	0.065
B8.06	572010506108	6 ~ 8	45	-			TS 211		0.08
B8.08	572010508108	8 ~ 10	60	-	-	TPGX 0902..	CS 250 T	TORX T08	0.1
B8.10	572010510108	10 ~ 12	75	-					0.2
B8.12	572010512108	12 ~ 14	90	-	-	TPGX 0902..	CS 250 T	TORX T08	0.3
B8.14	572010514108	14 ~ 16	105	-					0.2
B8.16	572010516108	16 ~ 18	120	-	0.3				



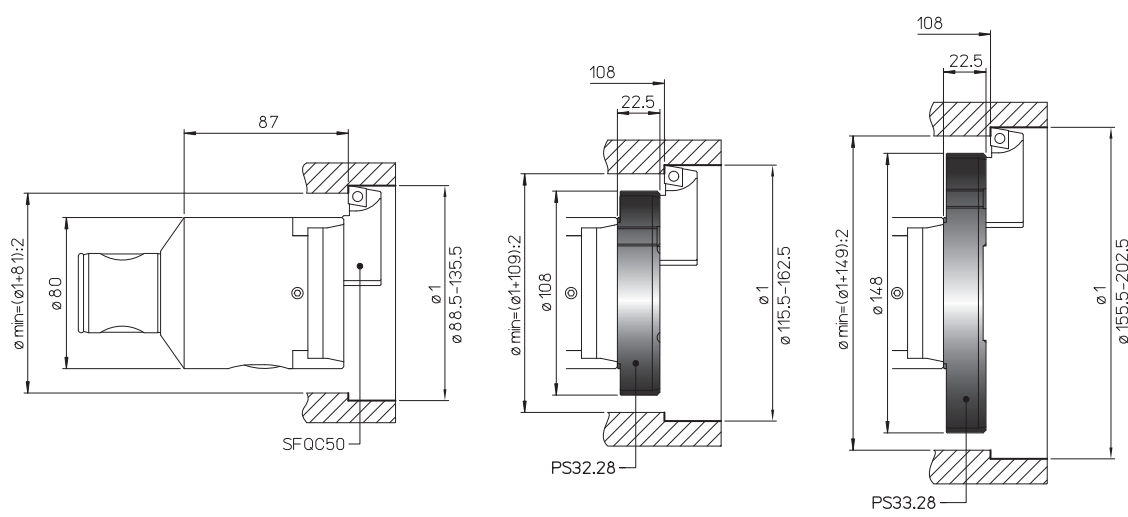
### TRC 80 Ø 85 ~ 202.5

- TOOLHOLDERS FOR TESTAROSSA
- WERKZEUGE FÜR TESTAROSSA
- PORTAHERRAMIENTAS PARA TESTAROSSA
- PORTE-OUTILS POUR TESTAROSSA
- PORTAUTENSILI PER TESTAROSSA

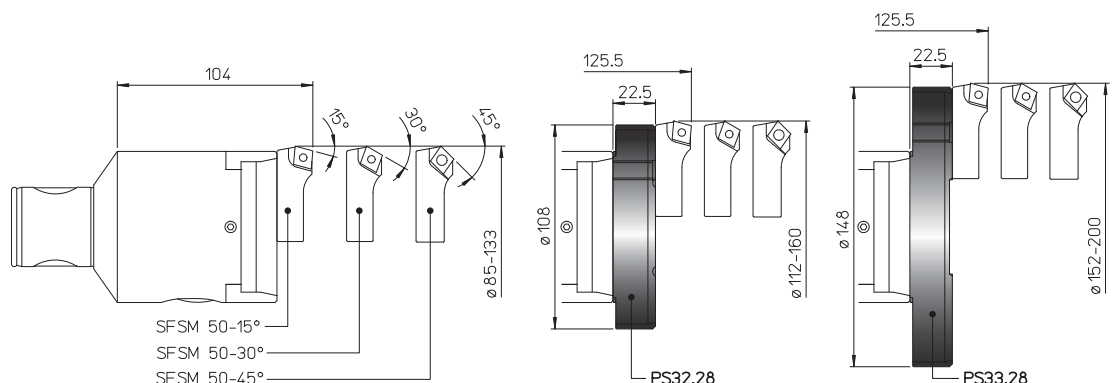
**PS**  
**CW 32**  
Ø 88~ 200



**PS**  
Ø 88.5 ~ 202.5



**PS**  
Ø 85 ~ 200



REF.	CODE	Kg.
PS 32.28 TRC 80	433028221081	0.5
PS 33.28 TRC 80	433028221481	0.6
CW 32	392011003201	0.07





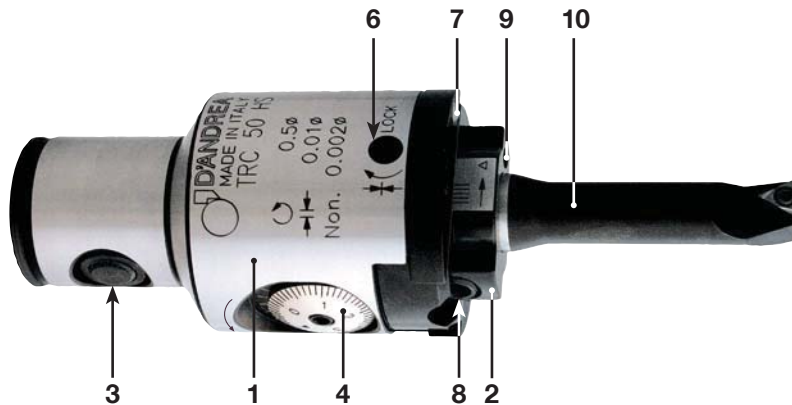
# D'ANDREA

## MODULHARD'ANDREA

## TRC HS

RPM MAX 12.000

Ø 2.5 ~ 22



**10 µm**  
nonio  
vernier 2 µm



- 1 • Body  
• Körper  
• Cuerpo  
• Corps  
• Corpo
- 2 • Slide toolholder  
• Werkzeugschlitten  
• Guía portaherramientas  
• Coulisseau  
• Slitta portautensili
- 3 • Expanding radial pin  
• Spreizbolzen  
• Perno radial expansible  
• Tige radiale expansible  
• Perno radiale espandibile
- 4 • Vernier scale  
• Nonius  
• Nonio  
• Vernier  
• Nonio
- 5 • Micrometric vernier scale  
• Mikrometrischer Nonius  
• Nonio micrométrico  
• Vernier micrométrique  
• Nonio micrometrico

## TRC 32 HS

Ø 2.5 ~ 18



## TRC 50 HS

Ø 2.5 ~ 22



**GB FEATURES.** High precision work to IT6 tolerance, with excellent surface finish, is achieved using TRC HS boring heads. These are very sensitive and radial correction of 5 micron can be effected directly on the machine and easily read on the vernier scale.

**D MERKMALE.** Die TRC HS Köpfe ermöglichen Bearbeitungen mit hoher Präzision und Toleranzen mit Grad IT6 bei hochwertiger Oberflächengüte. Sie besitzen eine Feinverstellung mit einer Genauigkeit von radial 5 µm, wobei das Maß auf der Skala abgelesen und auch direkt an der Maschine eingestellt werden kann.

**E CARACTERÍSTICAS.** Los cabezales TRC HS permiten realizar operaciones de alta precisión con tolerancias de grado IT6 con un extraordinario acabado de la superficie. Tienen una sensibilidad de ajuste de 5 micras en radio, de fácil lectura en el nonio y corregibles directamente sobre la máquina.

**F CARACTÉRISTIQUES.** Les têtes TRC HS permettent des usinages de haute précision avec des tolérances de degré IT6 comprenant un excellent finissage superficiel. Elles ont une sensibilité de réglage de 5 microns sur le rayon, facilement lisible sur le vernier et exécutable également dans la machine.

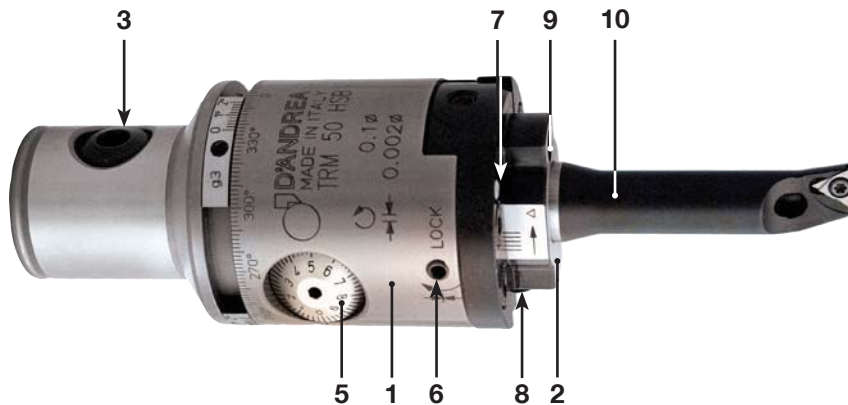
**I CARATTERISTICHE.** Le testine TRC HS consentono lavorazioni di alta precisione con tolleranze di grado IT6 con ottima finitura superficiale. Hanno una sensibilità di regolazione di 5 micron sul raggio, facilmente leggibile sul nonio ed eseguibile anche in macchina.



## TRM HSB

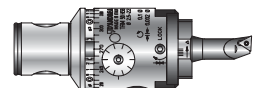
RPM MAX 20.000

Ø 2.5 ~ 22



- 6**
- Slide clamp screw
  - Schlittenklemmschraube
  - Tornillo bloqueo guía
  - Vis blocage coulisseau
  - Vite bloccaggio slitta
- 7**
- Coolant outlet
  - Kühlmittelaustritt
  - Agujero salida refrigerante
  - Sortie du liquide d'arrosage
  - Uscita refrigerante
- 8**
- Tools clamp screws
  - Werkzeugklemmschrauben
  - Tornillo bloqueo herramienta
  - Vis blocage outil
  - Viti bloccaggio utensile
- 9**
- Oiler
  - Schmiernippel
  - Engrasador
  - Graisseur
  - Oliatore
- 10**
- Tool
  - Werkzeug
  - Herramienta
  - Outil
  - Utensile

2 µm

TRM 32 HSB  
Ø 2.5 ~ 18TRM 50 HSB  
Ø 2.5 ~ 22

**GB FEATURES.** High precision work to IT6 tolerance, with excellent surface finish, is achieved using TRM HSB boring heads. These are very sensitive and radial correction of 1 micron can be effected directly on the machine and easily read on the vernier scale.

**D MERKMALE.** Die TRM HSB Köpfe ermöglichen Bearbeitungen mit hoher Präzision und Toleranzen mit Grad IT6 bei hochwertiger Oberflächengüte. Sie besitzen eine Feinverstellung mit einer Genauigkeit von radial 1 µm, wobei das Maß auf der Skala abgelesen und auch direkt an der Maschine eingestellt werden kann.

**E CARACTERÍSTICAS.** Los cabezales TRM HSB permiten realizar operaciones de alta precisión con tolerancias de grado IT6 con un extraordinario acabado de la superficie. Tienen una sensibilidad de ajuste de 1 micras en radio, de fácil lectura en el nonio y corregibles directamente sobre la máquina.

**F CARACTÉRISTIQUES.** Les têtes TRM HSB permettent des usinages de haute précision avec des tolérances de degré IT6 comprenant un excellent finissage superficiel. Elles ont une sensibilité de réglage de 1 micron sur le rayon, facilement lisible sur le vernier et exécutable également dans la machine.

**I CARATTERISTICHE.** Le testine TRM HSB consentono lavorazioni di alta precisione con tolleranze di grado IT6 con ottima finitura superficiale. Hanno una sensibilità di regolazione di 1 micron sul raggio, facilmente leggibile sul nonio ed eseguibile anche in macchina.



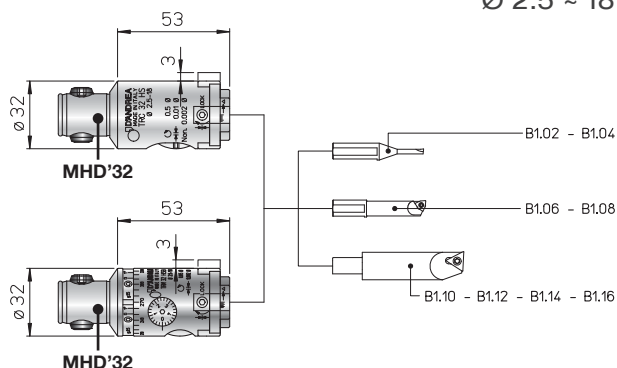


**TRC 32 HS**  
 Ø 2.5 ~ 18  
 RPM MAX 12.000

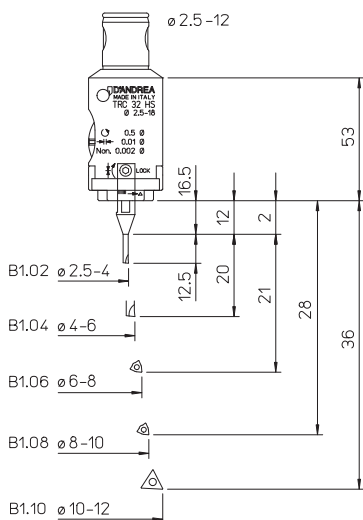
**TRC 32 HS**  
**TRM 32 HSB**  
 Ø 2.5 ~ 18



**TRM 32 HSB**  
 Ø 2.5 ~ 18  
 RPM MAX 20.000



REF.	CODE	Kg.
TRC 32 HS	455033200531	0.35
TRM 32 HSB	455103200531	

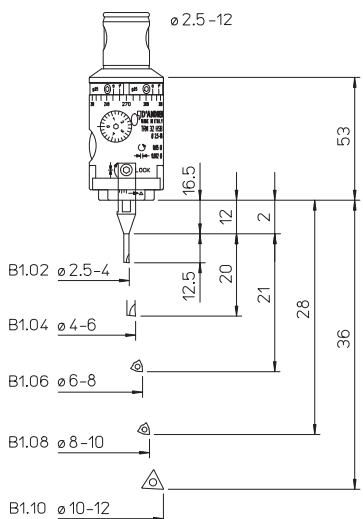


**KIT K01**  
**TRC 32 HS**  
 Ø 2.5 ~ 12



- 1 TRC32HS
- 1 B1.02
- 5 TPGX 090202L DC100
- 2 WCGT 020102L DC100
- 1 B1.04
- 1 B1.06
- 1 B1.08
- 1 B1.10

REF.	CODE	Ø
<b>KIT K01 TRC 32 HS</b>	655033230322	2.5 ~ 12



**KIT K01**  
**TRM 32 HSB**  
 Ø 2.5 ~ 12



- 1 TRM32HSB
- 1 B1.02
- 5 TPGX 090202L DC100
- 2 WCGT 020102L DC100
- 1 B1.04
- 1 B1.06
- 1 B1.08
- 1 B1.10

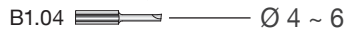
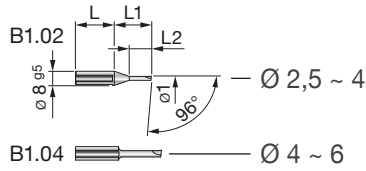
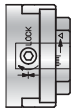
REF.	CODE	Ø
<b>KIT K01 TRM 32 HSB</b>	655003230321	2.5 ~ 12



B1

- Carbide tools
- Bohrstange aus hartmetall
- Herramientas de metal duro
- Outils carbure
- Utensili in metallo duro

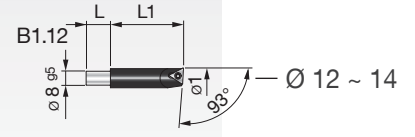
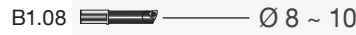
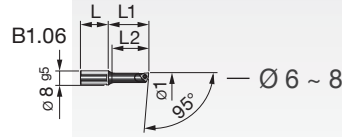
TRC32HS  
TRM32HSB



B1

- Tools
- Bohrstange
- Herramientas
- Outils
- Utensili

Ø 2.5 ~ 22



REF.	CODE	Ø1	L	L1	L2	Kg.
B1.02	572010502001	2.5 ~ 4	22	21	12.5	0.02
B1.04	572010504001	4 ~ 6	24	24	-	

REF.	CODE	Ø1	L	L1	L2	⊙	⊙	⊙	⊙	Kg.	
B1.06	572010506000	6 ~ 8	16	23	21	WCGT 0201..	-	TS 21	TORX T06	0.01	
B1.08	572010508000	8 ~ 10		28	-					TS 211	0.015
B1.10	572010510000	10 ~ 12		36						0.02	
B1.12	572010512000	12 ~ 14	14	42	-	-	TPGX 0902..	CS 250 T	TORX T08	0.03	
B1.14	572010514000	14 ~ 16		48						0.04	
B1.16	572010516000	16 ~ 18		54						0.05	





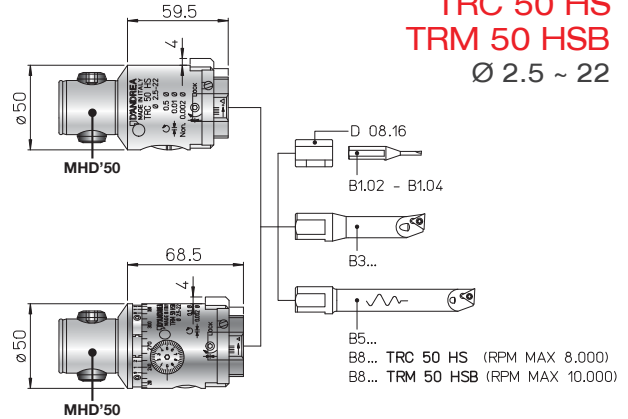
**10 µm**  
 nonio  
 vernier **2 µm**

**TRC 50 HS**  
 Ø 2.5 ~ 22  
 RPM MAX 12.000



**2 µm**

**TRM 50 HSB**  
 Ø 2.5 ~ 22  
 RPM MAX 20.000



**TRC 50 HS**  
**TRM 50 HSB**  
 Ø 2.5 ~ 22

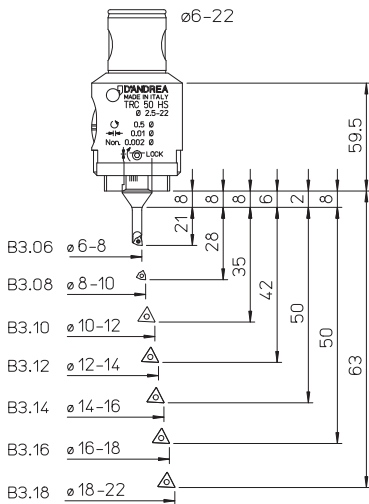
REF.	CODE	Kg.
TRC 50 HS	455035000601	1
TRM 50 HSB	455105000701	1.4

**KIT K01**  
**TRC 50 HS**  
 Ø 6 ~ 22



- 1 TRC50HS 1 B3.10 1 B3.16
- 1 B3.06 1 B3.12 1 B3.18
- 1 B3.08 1 B3.14
- 5 TPGX 090202L DC100
- 2 WCGT 020102L DC100

REF.	CODE	Ø
<b>KIT K01 TRC 50 HS</b>	655035030502	6 ~ 22



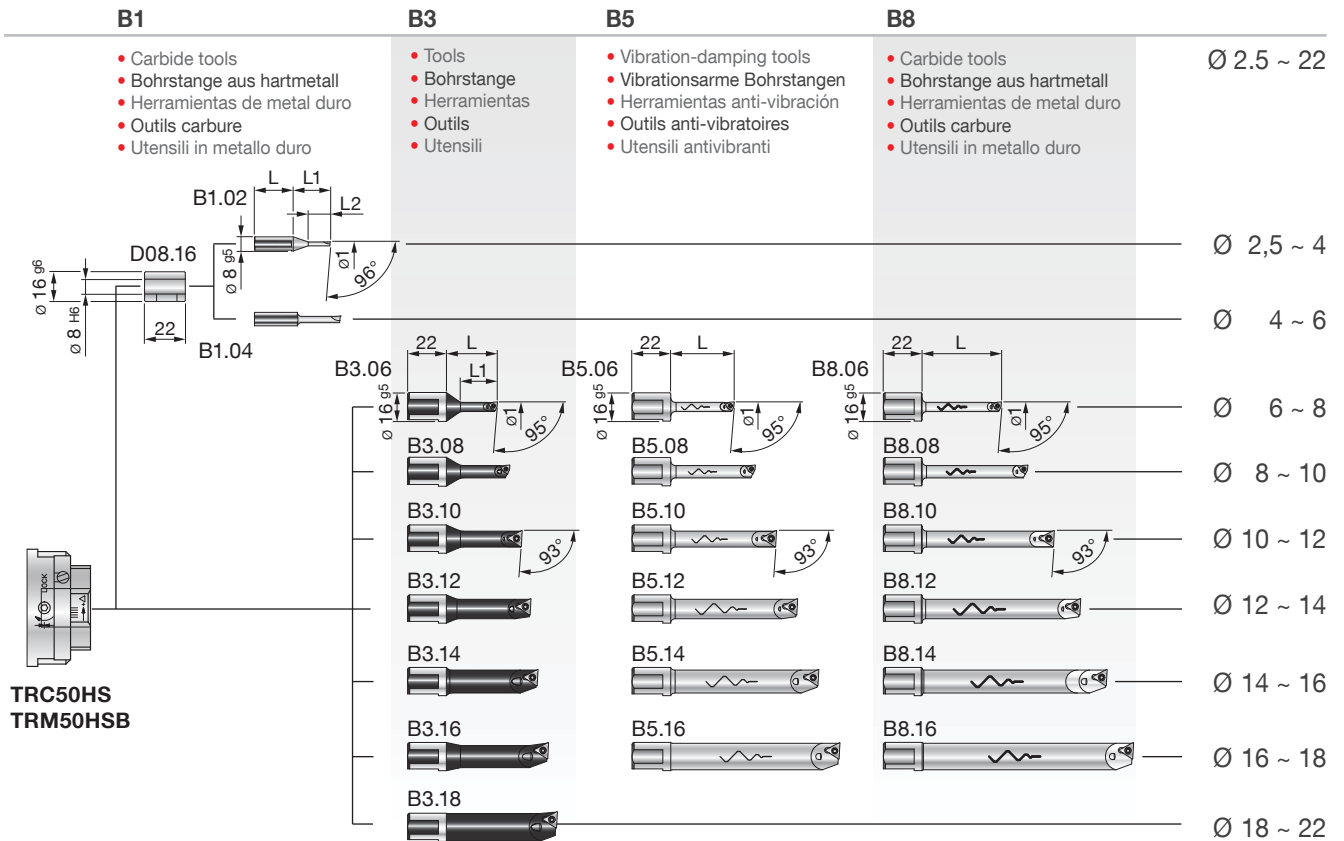
**KIT K01**  
**TRM 50 HSB**  
 Ø 6 ~ 22



- 1 TRM50HSB 1 B3.10 1 B3.16
- 1 B3.06 1 B3.12 1 B3.18
- 1 B3.08 1 B3.14
- 5 TPGX 090202L DC100
- 2 WCGT 020102L DC100

REF.	CODE	Ø
<b>KIT K01 TRM 50 HSB</b>	655005030501	6 ~ 22





REF.	CODE	Kg.
D08.16	200560116082	0.02

REF.	CODE	Ø1	L	L1	L2	Kg.
B1.02	572010502001	2.5 ~ 4	22	21	12.5	0.02
B1.04	572010504001	4 ~ 6	24	24	-	

REF.	CODE	Ø1	L	L1	⊖	⚠	🔧	🔩	Kg.
B3.06	572010506001	6 ~ 8	29	21	WCGT 0201..	-	TS 21	TORX T06	0.035
B3.08	572010508001	8 ~ 10	36	28					0.04
B3.10	572010510001	10 ~ 12	43	35	-	TPGX 0902..	CS 250 T	TORX T08	0.05
B3.11	572010511001	11 ~ 13	48	40					0.055
B3.12	572010512001	12 ~ 14	48	42					0.06
B3.14	572010514001	14 ~ 16	52	50					0.07
B3.16	572010516001	16 ~ 18	58	-					0.1
B3.18	572010518001	18 ~ 22	63	-					0.1

B5.06	572010506105	6 ~ 8	36	-	WCGT 0201..	-	TS 21	TORX T06	0.075
B5.08	572010508105	8 ~ 10	48						0.09
B5.10	572010510105	10 ~ 12	60		-	TPGX 0902..	CS 250 T	TORX T08	0.1
B5.12	572010512105	12 ~ 14	72						0.2
B5.14	572010514105	14 ~ 16	84						0.3
B5.16	572010516105	16 ~ 18	96						

B8.06	572010506108	6 ~ 8	45	-	WCGT 0201..	-	TS 21	TORX T06	0.065
B8.08	572010508108	8 ~ 10	60						0.08
B8.10	572010510108	10 ~ 12	75		-	TPGX 0902..	CS 250 T	TORX T08	0.1
B8.12	572010512108	12 ~ 14	90						0.2
B8.14	572010514108	14 ~ 16	105						0.3
B8.16	572010516108	16 ~ 18	120						

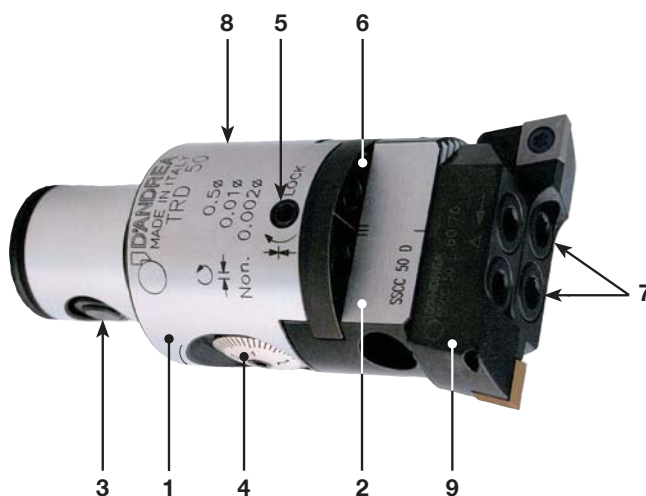


- DOUBLE-BIT TESTAROSSA
- TESTAROSSA ZWEISCHNEIDERKÖPFE
- TESTAROSSA DE DOS CUCHILLAS
- DOUBLE TRANCHANT TESTAROSSA
- TESTAROSSA BITAGLIENTE

# D'ANDREA

## MODULHARD'ANDREA

- Body  
• Körper  
• Cuerpo  
• Corps  
• Corpo
- Slide toolholder  
• Werkzeugschlitten  
• Guía portaherramientas  
• Coulisseau  
• Slitta portautensili
- Expanding radial pin  
• Spreizbolzen  
• Perno radial expansible  
• Tige radiale expansible  
• Perno radiale espandibile
- Vernier scale  
• Nonius  
• Nonio  
• Vernier  
• Nonio
- Slide clamp screw  
• Schlittenklemmschraube  
• Tornillo bloqueo guía  
• Vis blocage coulisseau  
• Vite bloccaggio slitta
- Coolant outlet  
• Kühlmittelaustritt  
• Agujero salida refrigerante  
• Sortie du liquide d'arrosage  
• Uscita refrigerante



- Tools clamp screws  
• Werkzeugklemmschrauben  
• Tornillos bloqueo herramienta  
• Vis blocage outil  
• Viti bloccaggio utensile
- Oiler  
• Schmiernippel  
• Engrasador  
• Graisseur  
• Oliatore
- Bit holder  
• Plattenhalter  
• Portaplaquita  
• Porte-plaquettes  
• Seggio portainserti

Dom. Brev. Dep.  
Patent Pending

**10 µm**  
nonio  
vernier **2 µm**



**GB** The main advantage of the TRD head is that it can be pre-regulated independently of the bit holders found on the slide. This allows both roughing and high precision finish work at the same time.

**D** Der Hauptvorteil der TRD Köpfe liegt darin, dass die auf dem Schlitten montierten Sitze unabhängig voneinander voreingestellt werden können. Dies ermöglicht gleichzeitige Grob- und Feinbearbeitungen.

**E** El punto fuerte de los TRD es el pre-ajuste independiente de los asientos montados sobre la corredera que permiten realizar a la vez operaciones de desbaste y acabado.

**F** L'avantage des TRD est le pré-réglage indépendant des logements montés sur le coulisseau qui permettent d'effectuer en même temps des travaux de dégrossissage et de finissage.

**I** Il punto di forza delle TRD è la pre-regolazione indipendente dei seggi montati sulla slitta che consentono di eseguire contemporaneamente lavorazioni di grossatura e di finitura.



**GB FEATURES.** The double-bit TRD heads allow both roughing and high precision finish thanks to their rigidity and the sensitivity of the sliding mechanism which can achieve radial correction of 5 microm. This can be effected directly on the machine and easily read on the vernier scale.

**D MERKMALE.** Die TRD Zweischneiderköpfe ermöglichen eine kombinierte und hochpräzise Vor- und Fertigbearbeitung. Dank der Steifigkeit und der auf radial 5 µm über Skala genauen Schlittenverstellung kann das Mass direkt an der Maschine korrigiert werden.

**E CARACTERÍSTICAS.** Los cabezales de dos cuchillas TRD permiten realizar operaciones combinadas de desbaste y acabado de alta precisión, gracias a su rigidez y a la sensibilidad del mecanismo de deslizamiento con ajuste de 5 micras en radio, que puede leerse en el nonio y realizarse directamente en la máquina.

**F CARACTÉRISTIQUES.** Les têtes à double tranchant TRD permettent le travail combiné de dégrossissage et finition de haute précision. Grâce à leur rigidité et à la sensibilité du déplacement du chariot avec un réglage de 5 microns sur le rayon, lisible sur le nonius et exécutable même dans la machine.

**I CARATTERISTICHE.** Le testine bitaglianti TRD consentono lavorazioni combinate di sgrossatura e finitura di alta precisione, grazie alla loro rigidezza e alla sensibilità dello spostamento slitta con regolazione di 5 micron sul raggio, leggibile sul nonio ed eseguibile anche in macchina.

**TRD 25**  
Ø 28 ~ 36



**TRD 32**  
Ø 36 ~ 46



**TRD 40**  
Ø 46 ~ 60



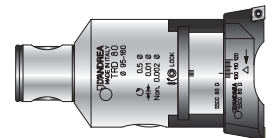
**TRD 50**  
Ø 60 ~ 75



**TRD 63**  
Ø 75 ~ 95



**TRD 80**  
Ø 95 ~ 160







- DOUBLE-BIT TESTAROSSA
- TESTAROSSA ZWEISCHNEIDERKÖPFE
- TESTAROSSA DE DOS CUCHILLAS
- DOUBLE TRANCHANT TESTAROSSA
- TESTAROSSA BITAGLIENTE

TRD

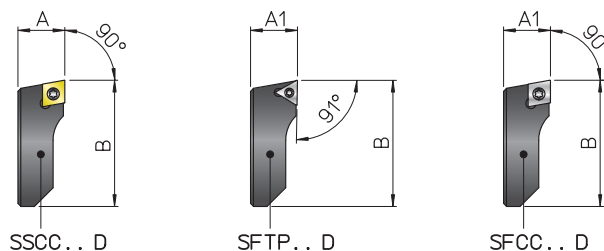


10 μm  
nonio  
vernier 2 μm

REF.	CODE	Kg.
TRD 25	455022500571	0.2
TRD 32	455023200711	0.35
TRD 40	455024000901	0.7
TRD 50	455025000861	1.5
TRD 63	455026301081	2.7
TRD 80	455028001291	4.8

- BIT-HOLDERS FOR DOUBLE-BIT TESTAROSSA
- PLATTENHALTER FÜR TESTAROSSA ZWEISCHNEIDERBOHRKÖPFE
- ASIENTOS PARA TESTAROSSA DE DOS CUCHILLAS
- DOUBLE TRANCHANT TESTAROSSA
- SEGGI PER TESTAROSSA BITAGLIENTE

SS-SF



REF.	CODE	A	A1	B					Kg.
SSCC 25 D	470500525220	10	-	24	-	CCMT 0602..	TS 25	TORX T08	0.008
SSCC 32 D	470500532220	11.5	-	30	-				0.015
SSCC 40 D	470500540220	14	-	40	-				0.03
SSCC 50 D	470500550220	19	-	54	-				0.06
SSCC 63 D	470500563220	24.5	-	68	-	CCMT 09T3..	TS 4	TORX T15	0.15
SSCC 80 D	470500580220	-	-	87	-				0.3
SSCC 85 D	470500585221	29.5	-	107.4	-				0.4
SFTP 25 D	470500525030	-	9.8	24	TPGX 0902..	-	CS 250T		0.008
SFTP 32 D	470500532030	-	11.3	30					0.015
SFTP 40 D	470500540030	-	13.8	40				TORX T08	0.03
SFTP 50 D	470500550030	-	18.8	54					0.06
SFTP 63 D	470500563030	-	24.3	68	TPGX 1103..	-	CS 300890T		0.15
SFTP 80 D	470500580030	-	-	87					0.3
SFTP 85 D	470500585031	-	29.3	107.4					0.4
SFCC 25 D	470500525020	-	9.8	24	-	CCGT 0602..	TS 25	TORX T08	0.008
SFCC 32 D	470500532020	-	11.3	30	-				0.015
SFCC 40 D	470500540020	-	13.8	40	-				0.03
SFCC 50 D	470500550020	-	18.8	54	-				0.06
SFCC 63 D	470500563020	-	24.3	68	-	CCGT 09T3..	TS 4	TORX T15	0.15
SFCC 80 D	470500580020	-	-	87	-				0.3
SFCC 85 D	470500585021	-	29.3	107.4	-				0.4

116

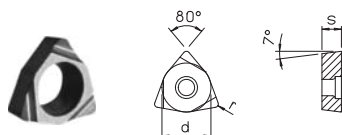
120

118



- INSERTS
- WENDEPLATTEN
- PLAQUITAS
- PLAQUÉTTES
- INSERTI

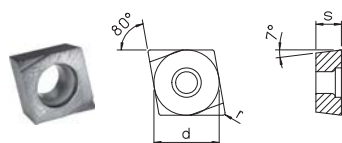
### WCGT ○○○○○○L



REF.	d	s	r	T	S	CARBIDE		CERMET	COATED CERMET
						DP300	DK100	DC100	DC100T
WCGT 020102 L	3.97	1.59	0.2	TS 21*-TS 211*	TORX T06	•	•	•	•
WCGT 020104 L			0.4			•	•	•	•

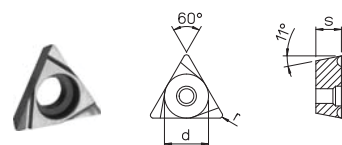
\* TS21 : B...06  
\* TS211 : B...08

### CCGT ○○○○○○L



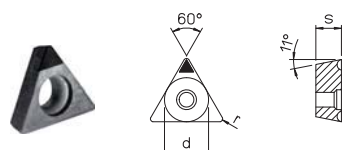
REF.	d	s	r	T	S	CARBIDE		CERMET	COATED CERMET
						DP300	DK100	DC100	DC100T
CCGT 060200 L10°	6.35	2.38	0	TS 25	TORX T08	•	•	•	•
CCGT 060202 L			0.2			•	•	•	•
CCGT 060204 L			0.4			•	•	•	•
CCGT 09T302 L	9.525	3.97	0.2	TS 4	TORX T15	•	•	•	•
CCGT 09T304 L			0.4			•	•	•	•

### TPGX ○○○○○○L



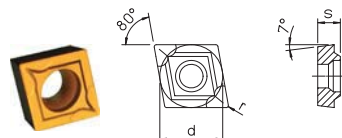
REF.	d	s	r	T	S	CARBIDE		CERMET	COATED CERMET
						DP300	DK100	DC100	DC100T
TPGX 090200 L10°	5.56	2.38	0	CS250T	TORX T08	•	•	•	•
TPGX 090202 L			0.2			•	•	•	•
TPGX 090204 L			0.4			•	•	•	•
TPGX 110300 L10°	6.35	3.18	0	CS300890T	TORX T08	•	•	•	•
TPGX 110302 L			0.2			•	•	•	•
TPGX 110304 L			0.4			•	•	•	•

### TPGX ○○○○○○



REF.	d	s	r	T	S	SINTERED DIAMOND	CUBIC BORON NITRIDE	
						D20 MDC	D20 CBN	D25 CBN
TPGX 090202	5.56	2.38	0.2	CS250T	TORX T08	•	•	•
TPGX 090204			0.4			•	•	•
TPGX 110302	6.35	3.18	0.2	CS300890T	TORX T08	•	-	•
TPGX 110304			0.4			•	•	•

### CCMT ○○○○○○



REF.	d	s	r	T	S	CARBIDE	CVD COATED CARBIDE
						DP300	DP100 R
CCMT 060202	6.35	2.38	0.2	TS 25	TORX T08	•	•
CCMT 060204			0.4			•	•
CCMT 09T304	9.525	3.97	0.4	TS 4	TORX T15	•	•
CCMT 09T308			0.8			•	•
CCMT 120404			0.4			•	•
CCMT 120408	12.7	4.76	0.8	TS 5	TORX T25	•	•



- BORING GRADE
- ÜBERSICHT AUSBOHRQUALITÄTEN
- CALIDAD DE MANDRINADO
- QUALITÉ D'ALÉSAGE
- QUALITÀ DI BARENATURA

ISO	CARBIDE HARTMETALL METAL DURO CARBURE METALLO DURO	CERMET	COATED CERMET CERMET BESCHICHTET CERMET RECUBIERTO CERMET REVÊTU CERMET RIVESTITO	CVD COATED CARBIDE HARTMETALL CVD BESCHICHTET METAL DURO RECUBIERTO CVD CARBURE REVÊTU CVD METALLO DURO RIVESTITO CVD
P01				
P10		DC100	DC100T	DP100R
P20	DP300			
P30				
P40				
K01		DC100	DC100T	DP100R
K10	DK100			
K20	DP300			
K30				

**DP300**

- Roughing and finishing. Low carbon steel - stainless steels
- Schruppen und Schlichten. Stahl mit niedrigem Kohlenstoffgehalt - rostfreier Stahl
- Desbaste y acabado. Aceros con bajo contenido de carbono - Aceros inoxidables
- Ébauche et finition. Acier à bas teneur en carbon - acier inoxydable
- Sgrossatura e finitura. Acciai a basso tenore di carbonio - acciai inox

**DK100**

- Roughing and finishing. Aluminium alloy Cast iron
- Schruppen und Schlichten. Aluminium-Legierungen Gusseisen
- Desbaste y acabado. Aleaciones de aluminio Fundiciones
- Ébauche et finition. Alliage aluminium Fonte
- Sgrossatura e finitura. Leghe di alluminio Ghise

**DP100R**

- Roughing. Steels, alloy steels and cast iron
- Schruppen. Stahl, legierter Stahl und Gusseisen
- Desbaste. Aceros, aceros aleados y fundiciones
- Ébauche. Aciers, alliage acier et fonte
- Sgrossatura. Acciai, acciai legati e ghise

**DC100**

- Finishing. Alloy steels and cast iron
- Schlichten. Legierter Stahl und Gusseisen
- Acabado. Aceros aleados en general y fundiciones esferoidales
- Finition. Alliage acier et fonte ductile
- Finitura. Acciai legati in genere e ghise sferoidali

**DC100T**

- Finishing. Alloy steels, stainless steels and cast iron
- Schlichten. Legierter Stahl, rostfreier Stahl und Gusseisen
- Acabado. Aceros aleados en general, aceros inoxidables y fundiciones esferoidales
- Finition. Alliage acier, acier inoxydable et fonte ductile
- Finitura. Acciai legati in genere, acciai inox e ghise sferoidali

**D20MDC**

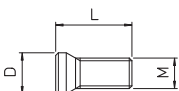
- Finishing. Aluminium alloys, non-ferrous materials and non-metals
- Schlichten. Aluminium-Legierungen, Nichteisenmetalle und nicht-metallische Materialien
- Acabado. Aleaciones de aluminio, materiales no ferrosos y no metálicos
- Finition. Alliage aluminium, non-ferreux et composites
- Finitura. Leghe di alluminio, materiali non-ferrosi e non-metalli

**D20CBN**

- Finishing. High hardness steels (over 50 HRC) (it may replace the grinding)
- Schlichten. Stahl mit Härte über 50 HRC (kann gegebenenfalls das Schleifen ersetzen)
- Acabado. Aceros de dureza elevada superior a 50 HRC (puede sustituir el rectificado)
- Finition. Acier à haute dureté, supérieure à 50 HRC (il peut remplacer la rectification)
- Finitura. Acciai con elevata durezza superiore 50 HRC (può sostituire la rettifica)

**D25CBN**

- Finishing. High hardness steel (over 50 HRC) and interrupted cutting (it may replace the grinding)
- Schlichten. Stahl mit Härte über 50 HRC und bei unterbrochenem Schnitt (kann gegebenenfalls das Schleifen ersetzen)
- Acabado. Aceros de dureza elevada superior a 50 HRC y corte interrumpido (puede sustituir el rectificado)
- Finition. Acier à haute dureté, supérieure à 50 HRC et coupe interrompue (il peut remplacer la rectification)
- Finitura. Acciai con elevata durezza superiore 50 HRC e taglio interrotto (può sostituire la rettifica)

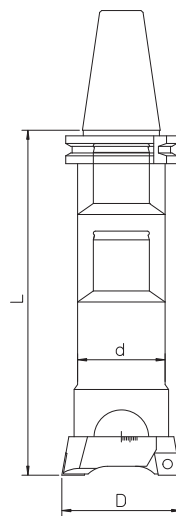


TORX

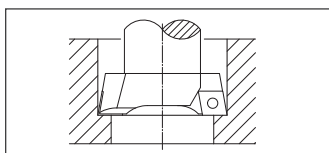
REF.	CODE	M	L	D	REF.	CODE
TS 21	494010002034	M 2x0.4	3.7	2.7	TORX T06	10 150 09 0 0600
TS 211	494010002040		4			
CS 250 T	494010002565	M 2.5x0.45	6	3.7	TORX T08	10 150 09 0 0800
CS 300890 T	494010003008	M 3x0.5	8	4.1		
TS 25	494010002555	M 2.5x0.45	5.7	3.45	TORX T15	10 150 09 0 1500
TS 4	494010004008	M 4x0.7	10	5.5		
TS 5	494010005009	M 5x0.8	11.5	7	TORX T25	10 150 09 0 2500
DMC US63	494210035070	M 3.5x0.6	10	5.2	TORX T15	10 150 09 0 1500

• **RECOMMENDED CUTTING CONDITIONS FOR ROUGHING OPERATIONS WITH DOUBLE-BIT HEADS TS**  
 • **DATI DI TAGLIO CONSIGLIATI PER SGROSSATURA DI FORI CON TESTINE BITAGLIENTI TS**

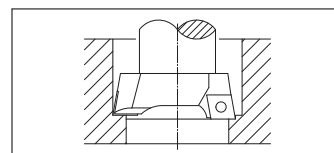
material materiale	boring bar dimensions dimensioni bareno	working conditions condizioni di lavoro	cutting speed $V_c = m/min.$ velocità di taglio $V_c = m/min.$			feed $f_n = mm/rev$ (twin cutters) avanzamento $f = mm/giro$ (due taglienti)		
			D < 38	diameter diametro		R = 0.2	insert radius raggio inserto	
				D = 38-120	D > 120		R = 0.4	R = 0.8
carbon steel acciaio al carbonio HB ≤ 200	L / d = 2.5	good / buona	120 - 180	140 - 200	160 - 250	-	0.2 - 0.4	0.3 - 0.5
	L / d = 4	normal / normale	100 - 160	120 - 180	140 - 200	-	0.2 - 0.4	0.3 - 0.5
	L / d = 6.3	difficult / difficile	70 - 100	70 - 100	70 - 100	0.15 - 0.3	0.2 - 0.4	-
carbon steel acciaio al carbonio HB > 200	L / d = 2.5	good / buona	100 - 160	120 - 180	140 - 200	-	0.2 - 0.4	0.3 - 0.5
	L / d = 4	normal / normale	80 - 140	100 - 160	120 - 180	-	0.2 - 0.4	0.3 - 0.5
	L / d = 6.3	difficult / difficile	60 - 90	70 - 100	70 - 100	0.15 - 0.3	0.2 - 0.4	-
stainless steel acciaio inox AISI 304 - 316	L / d = 2.5	good / buona	80 - 110	90 - 120	100 - 140	-	0.2 - 0.4	0.3 - 0.5
	L / d = 4	normal / normale	70 - 100	80 - 110	90 - 120	-	0.2 - 0.4	0.3 - 0.5
	L / d = 6.3	difficult / difficile	60 - 90	60 - 90	60 - 90	0.15 - 0.3	0.2 - 0.4	-
cast iron ghisa	L / d = 2.5	good / buona	90 - 120	100 - 140	120 - 160	-	0.2 - 0.4	0.3 - 0.5
	L / d = 4	normal / normale	70 - 100	90 - 120	100 - 140	-	0.2 - 0.4	0.3 - 0.5
	L / d = 6.3	difficult / difficile	60 - 90	60 - 90	60 - 90	0.15 - 0.3	0.2 - 0.4	-
aluminium alluminio	L / d = 2.5	good / buona	160 - 250	200 - 300	250 - 350	-	0.3 - 0.5	0.4 - 0.6
	L / d = 4	normal / normale	140 - 200	160 - 250	200 - 300	-	0.3 - 0.5	0.4 - 0.6
	L / d = 6.3	difficult / difficile	100 - 150	100 - 150	100 - 150	0.2 - 0.4	0.3 - 0.5	-



cutting depth profondità di passata	working range campo di lavoro	max. cutting depth max. profondità di passata	
		steel acciaio	cast iron, aluminium ghisa, alluminio
ap = mm	Ø = mm		
	18 - 28	1.5 - 2	2 - 2.5
	28 - 50	2 - 3	2.5 - 3.5
	50 - 68	3 - 4	3.5 - 5
	68 - 200	4 - 5	5 - 7
	200 - 500	5 - 6	6 - 8



- Twin cutters at the same cutting diameter
- Due taglienti sullo stesso diametro



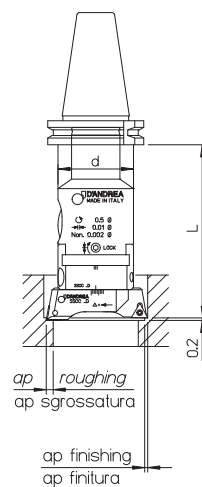
- Twin cutters at different cutting diameters
- Due taglienti su diametri diversi

- It's advisable to start with B hole ≥ the boring bar diameter d.
- È consigliabile che il preforo B sia ≥ al diametro del bareno d.

- **ATTENTION:** For boring operations at different diameters, reduce to a half the feed indicated on the above table.
- **ATTENZIONE:** Per lavorare con un solo tagliente o con differenti diametri di taglio, dimezzare l'avanzamento indicato in tabella.

• **RECOMMENDED CUTTING CONDITIONS FOR BORING OPERATIONS WITH DOUBLE-BIT TESTAROSSA TRD**  
 • **DATI DI TAGLIO CONSIGLIATI PER ALESATURA CON TESTAROSSA BITAGLIENTE TRD**

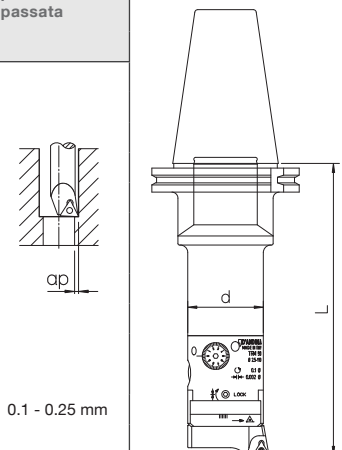
material materiale	boring bar dimensions dimensioni bareno	working conditions condizioni di lavoro	cutting speed $V_c = m/min.$ velocità di taglio $V_c = m/min.$	feed $f_n = mm/rev$ avanzamento $f_n = mm/giro$		quality insert qualità inserto		cutting depth profondità di passata			
				insert radius raggio inserto		roughing sgrossatura	finishing finitura	roughing sgrossatura			
				R = 0.2	R = 0.4			ø28 ø46	ø46 ø75	ø75 ø160	
carbon steel acciaio al carbonio HB ≤ 200	L / d = 2.5	good / buona	160 - 250	0.1 - 0.2	0.1 - 0.2	DC100 DP300	DP300 DP100R	0.15 - 0.3	1.5	2	2.5
	L / d = 4	normal / normale	120 - 180	0.1 - 0.2	0.1 - 0.2						
	L / d = 6.3	difficult / difficile	70 - 100	*0.1 - 0.15	0.1 - 0.2						
carbon steel acciaio al carbonio HB > 200	L / d = 2.5	good / buona	140 - 200	0.1 - 0.2	0.1 - 0.2	DC100	DP300 DP100R	0.15 - 0.3	1.5	2	2.5
	L / d = 4	normal / normale	100 - 160	0.1 - 0.2	0.1 - 0.2						
	L / d = 6.3	difficult / difficile	70 - 100	*0.1 - 0.15	0.1 - 0.2						
stainless steel acciaio inox AISI 304 - 316	L / d = 2.5	good / buona	100 - 140	0.1 - 0.2	0.1 - 0.2	DP300	DP300	0.15 - 0.3	1.5	2	2.5
	L / d = 4	normal / normale	80 - 110	0.1 - 0.2	0.1 - 0.2						
	L / d = 6.3	difficult / difficile	60 - 90	*0.1 - 0.15	0.1 - 0.2						
cast iron ghisa	L / d = 2.5	good / buona	120 - 160	0.1 - 0.2	0.1 - 0.2	DK100 DC300	DP100R	0.15 - 0.3	2	2.5	3
	L / d = 4	normal / normale	90 - 120	0.1 - 0.2	0.1 - 0.2						
	L / d = 6.3	difficult / difficile	60 - 90	*0.1 - 0.15	0.1 - 0.2						
aluminium alluminio	L / d = 2.5	good / buona	250 - 350	0.1 - 0.2	0.1 - 0.2	DK100	DK100	0.15 - 0.3	2	2.5	3
	L / d = 4	normal / normale	160 - 250	0.1 - 0.2	0.1 - 0.2						
	L / d = 6.3	difficult / difficile	100 - 150	*0.1 - 0.15	0.1 - 0.2						



\* Only for finishing inserts  
 \* Solo per inserti di finitura



- RECOMMENDED CUTTING CONDITIONS FOR BORING OPERATIONS WITH TESTAROSSA TR-E / TRM / TRC / TR-PSC
- DATI DI TAGLIO CONSIGLIATI PER L'ALESATURA CON TESTAROSSA TR-E / TRM / TRC / TR-PSC

material materiale	boring bar dimensions dimensioni bareno	working conditions condizioni di lavoro	cutting speed $V_c = m/min.$ velocità di taglio $V_c = m/min.$	feed $f_n = mm/rev$ avanzamento $f_n = mm/giro$			quality insert qualità inserto	cutting depth profondità di passata	
				insert radius raggio inserto					
				R = 0.0	R = 0.2	R = 0.4			
carbon steel acciaio al carbonio $HB \leq 200$	L / d = 2.5	good / buona	200 - 300	-	0.05 - 0.08	0.07 - 0.1	DC100 DP300		
	L / d = 4	normal / normale	160 - 250	-	0.05 - 0.08	0.07 - 0.1			
	L / d = 6.3	difficult / difficile	70 - 100	0.05 - 0.08	0.05 - 0.08	-			
carbon steel acciaio al carbonio $HB > 200$	L / d = 2.5	good / buona	160 - 250	-	0.05 - 0.08	0.07 - 0.1	DC100		
	L / d = 4	normal / normale	150 - 200	-	0.05 - 0.08	0.07 - 0.1			
	L / d = 6.3	difficult / difficile	70 - 100	0.05 - 0.08	0.05 - 0.08	-			
stainless steel acciaio inox AISI 304 - 316	L / d = 2.5	good / buona	120 - 160	-	0.05 - 0.08	0.07 - 0.1	DP300		
	L / d = 4	normal / normale	100 - 140	-	0.05 - 0.08	0.07 - 0.1			
cast iron ghisa	L / d = 2.5	good / buona	120 - 160	-	0.05 - 0.08	0.07 - 0.1	DK100 DC100		
	L / d = 4	normal / normale	100 - 140	-	0.05 - 0.08	0.07 - 0.1			
	L / d = 6.3	difficult / difficile	70 - 100	0.05 - 0.08	0.05 - 0.08	-			
aluminium alluminio	L / d = 2.5	good / buona	300 - 400	-	0.05 - 0.08	0.07 - 0.1	DK100		
	L / d = 4	normal / normale	250 - 350	-	0.05 - 0.08	0.07 - 0.1			
	L / d = 6.3	difficult / difficile	100 - 150	0.05 - 0.08	0.05 - 0.08	-			
steel acciaio $HB \leq 200$	L / d = 2.5	good / buona	80 - 100	-	0.04 - 0.06	0.05 - 0.07	D20CBN		
	L / d = 4	normal / normale	80 - 100	-	0.04 - 0.06	0.05 - 0.07			

- CALCULATION FORMULAS FOR BORING
- FORMULA DI CALCOLO PER ALESATURA

**V<sub>c</sub>** • cutting speed (m/min.)  
• velocità di taglio (m/min.)

$$V_c = \frac{\pi \cdot D \cdot n}{1000}$$

**D** • diameter of workpiece (mm)  
• diametro del pezzo da lavorare (mm)

**n** • number of revolutions / min' (rev./min.)  
• numero di giri al minuto (giri/min.)

$$n = \frac{V_c \cdot 1000}{\pi \cdot D}$$

**V<sub>f</sub>** • feed rate (mm/min.)  
• velocità avanzamento (mm/min.)

$$V_f = n \cdot f_n$$

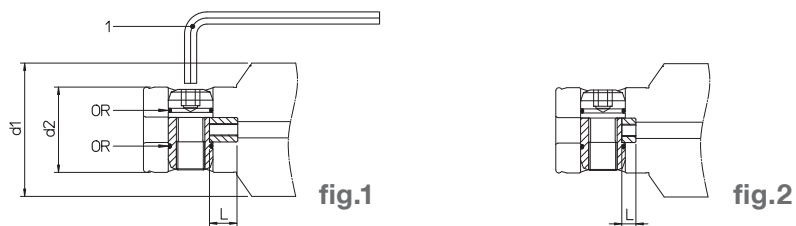
**f<sub>n</sub>** • feed / rev. (mm/rev)  
• avanzamento al giro (mm/giro)

**π** • 3.14



- SPARE PARTS
- ERSATZTEILE
- PIEZAS DE RECAMBIO
- PIÈCES ETACHÉES
- PARTI DI RICAMBIO

### SYSTEM MHD'



REF.	CODE	d1	d2	CODE 1	CODE OR	L	fig.
MHD' 14	381725001161	14	10	101500100250	-	2	2
MHD' 16		16					
MHD' 20	381725001201	20	13	101500100300	-	2.5	
MHD' 25	381725001251	25	16			3	
MHD' 32	381725001321	32	20	101500100400	101254007510	3.55	
MHD' 40	381725001401	40	25	101500100500	101254010010	4	
MHD' 50 RD 50 / .. TR-E - TRM - TRC - TRD	381725001501	50	32	101500100600	101254013010	4.2	
MHD' 50	381725001001					12.2	
MHD' 63-80	381725001002	63-80	42	101500100800	101251002075	13.85	1
MHD' 110 - 140	381725001003	110-140	76	101500101400	101251003112	10	

TS

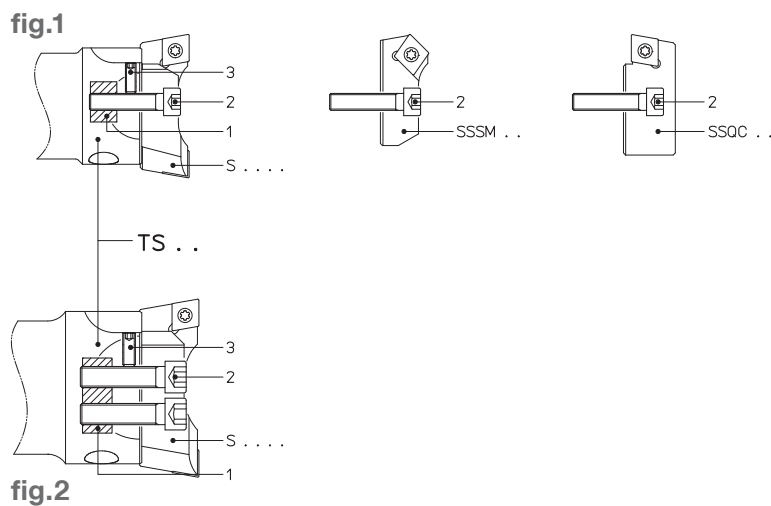
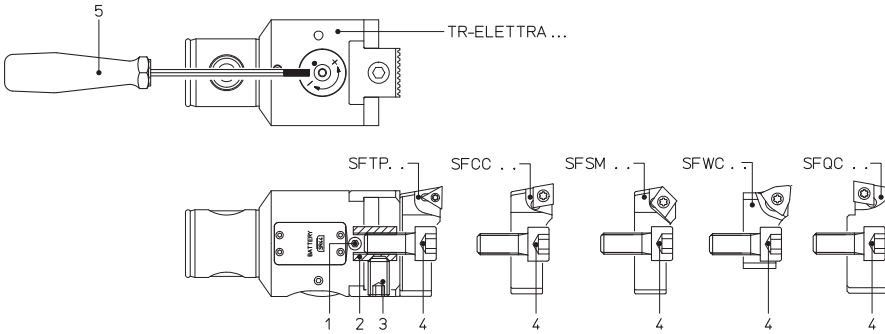


fig.	REF.	CODE 1	CODE 2	CODE 3
1	TS 16/16	201430110008	100051030014	100231030004
	TS 20/20	201430110009	100051040015	100231030005
	TS 25/25	201430110010	100051040020	100231030008
	TS 32/32	201430110011	100051050025	100231040012
	TS 40/40	201430110012	100051060030	100231050014
2	TS 50/50	201430110013	100051080035	100231050012
	TS 50/63	201430110014	100051100040	100231060016
	TS 63/63			
	TS 80/80	201430110015	100051120045	100231080025



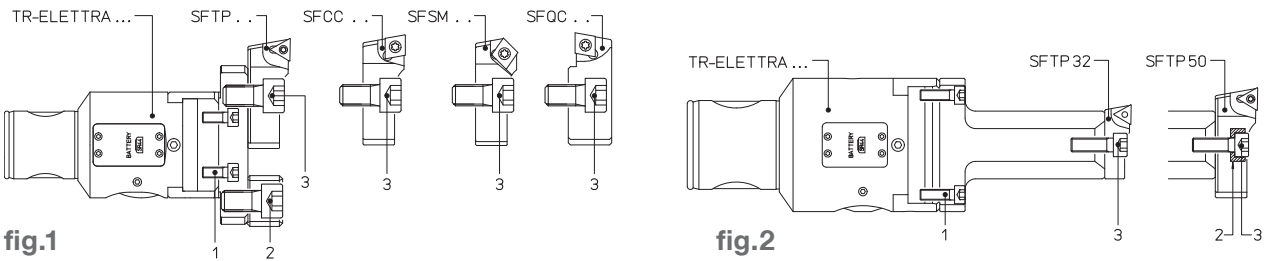
- SPARE PARTS
- ERSATZTEILE
- PIEZAS DE RECAMBIO
- PIÈCES ETACHÉES
- PARTI DI RICAMBIO

TR-ELETTRA



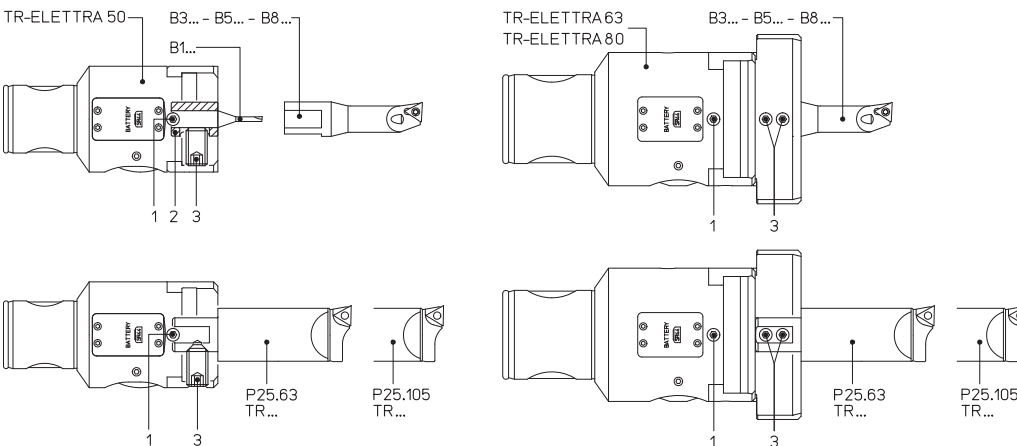
REF.	CODE 1	CODE 2	CODE 3	CODE 4	CODE 5
TR-ELETTRA 32	100238050007	-	-	100051060012	101500800250
TR-ELETTRA 40				100051080014	101500800300
TR-ELETTRA 50	100238060010	201041015002	100231100016	100051100025	101500800250
TR-ELETTRA 63		-	-	100051100020	
TR-ELETTRA 80	200100150614				100051100025

TR-ELETTRA



REF.	CODE 1	CODE 2	CODE 3	fig
TR-ELETTRA 50	200100150501	100051100020	100051100025	1
TR-ELETTRA 63	100051050025			
TR-ELETTRA 80	100051050016			
TR-ELETTRA 63	100051050016	201040607001	100051006020	2
TR-ELETTRA 80				

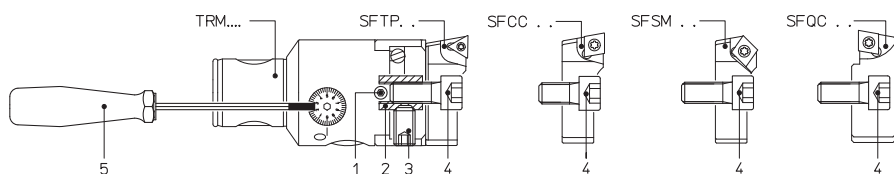
TR-ELETTRA



REF.	CODE 1	CODE 2	CODE 3
TR-ELETTRA 50	100238060010	200560116082	100231100016
TR-ELETTRA 63		-	100231060006
TR-ELETTRA 80	200100150614		

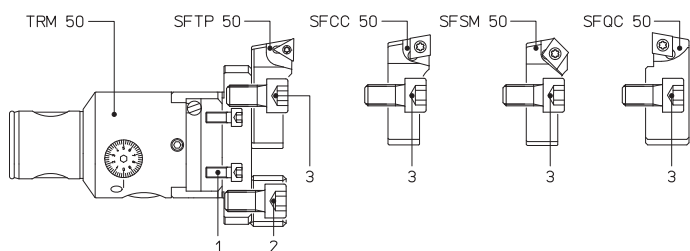
- SPARE PARTS
- ERSATZTEILE
- PIEZAS DE RECAMBIO
- PIÈCES ETACHÉES
- PARTI DI RICAMBIO

TRM



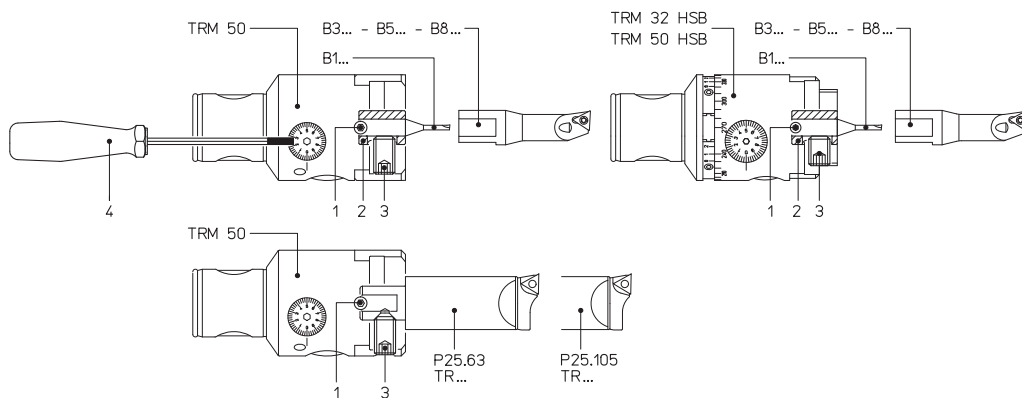
REF.	CODE 1	CODE 2	CODE 3	CODE 4	CODE 5
TRM 16	200100190301	-	-	100051030006	101500800150
TRM 20				100051040008	
TRM 25	100051050010			101500800200	
TRM 32	100051060012				
TRM 40	100051080014			101500800250	
TRM 50	100271050008	201041015002	100231100016		100051100025

TRM



REF.	CODE 1	CODE 2	CODE 3
TRM 50	200100150501	100051100020	100051100025

TRM

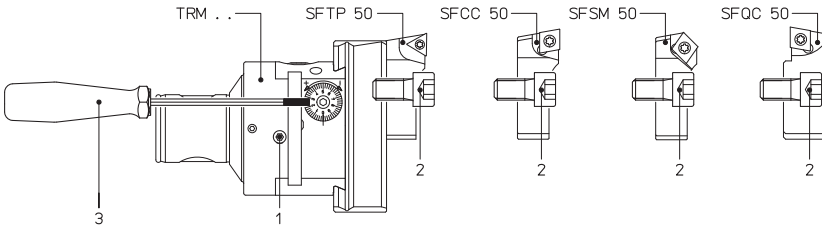


REF.	CODE 1	CODE 2	CODE 3	CODE 4
TRM 50	100271050008	200560116082	100231100016	101500800250
TRM 32 HSB	100271040005	-	100231050008 100231050012	101500800200
TRM 50 HSB	100271050008	200560116082	100231100010	101500800250



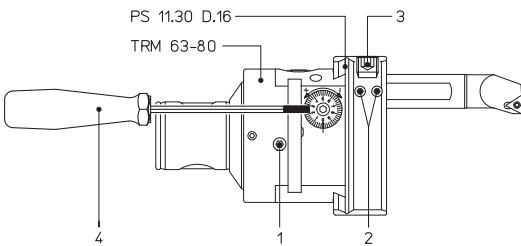
- SPARE PARTS
- ERSATZTEILE
- PIEZAS DE RECAMBIO
- PIÈCES ETACHÉES
- PARTI DI RICAMBIO

TRM



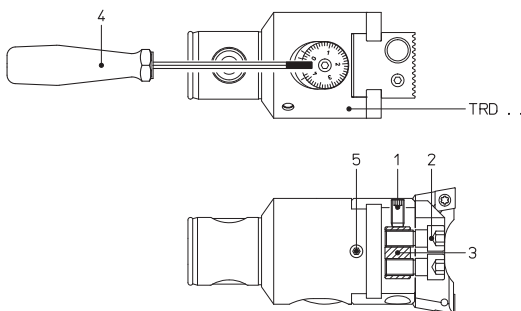
REF.	CODE 1	CODE 2	CODE 3
TRM 63	100251060010	100051100018	101500800300
TRM 80	100251060014		
TRM 125	100251060020		

TRM



REF.	CODE 1	CODE 2	CODE 3	CODE 4
TRM 63	100251060010	100231050006	100231100010	101500800300
TRM 80	100251060014			

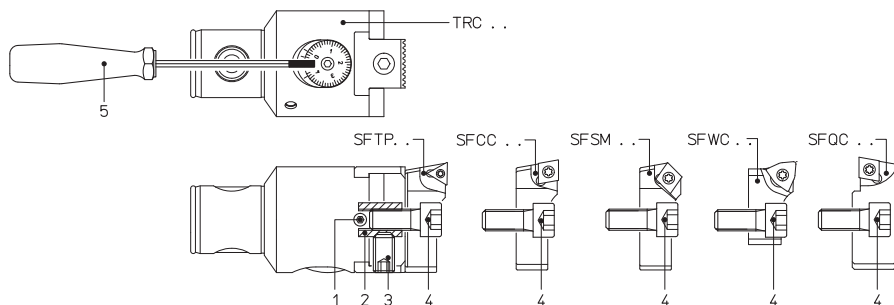
TRD



REF.	CODE 1	CODE 2	CODE 3	CODE 4	CODE 5
TRD 25	100231040008	200100150411	201430110024	101500800200	100271040004
TRD 32	100231050010	200100150512	201430110023	101500800250	100271050006
TRD 40	100231060012	200100150616	201430170001	101500800300	100271060006
TRD 50	100231060014	200100150820	201430110021		100271060008
TRD 63	100231060016	200100151026	201430110026		100271060012
TRD 80	100231060020	200100151230	201430110022		

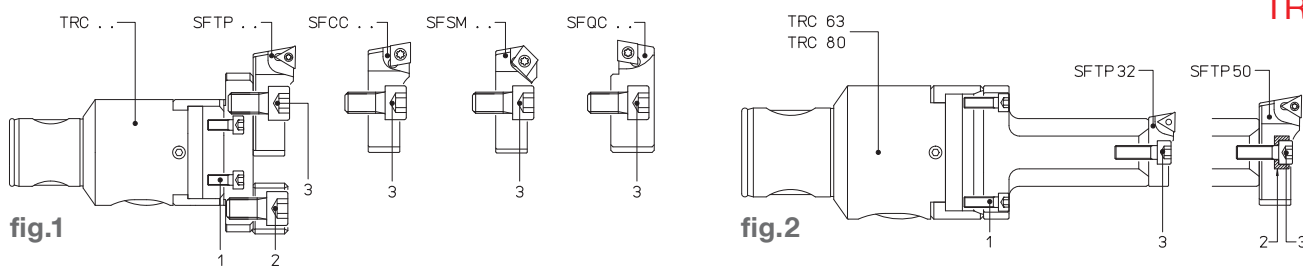
- SPARE PARTS
- ERSATZTEILE
- PIEZAS DE RECAMBIO
- PIÈCES ETACHÉES
- PARTI DI RICAMBIO

TRC



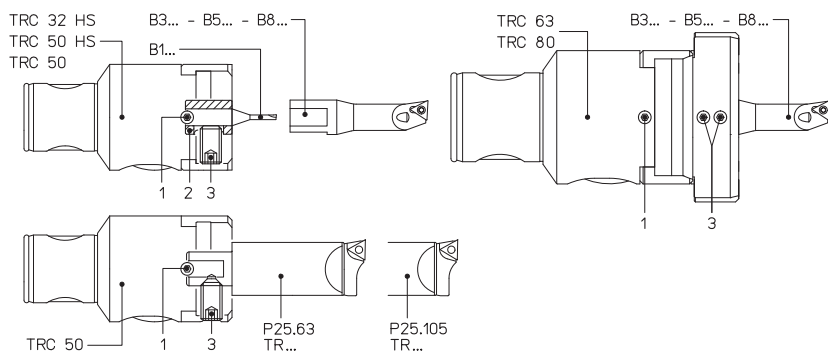
REF.	CODE 1	CODE 2	CODE 3	CODE 4	CODE 5
TRC 14	200100190302			100051030006	101500800150
TRC 16	200100190301			100051040008	
TRC 20				100051050010	
TRC 25	100271040004	-	-	100051060012	101500800250
TRC 32	100271050005			100051080014	101500800300
TRC 40	100271060006			100051100025	
TRC 50	100271060008	201041015002	100231100016	100051100020	
TRC 63				100051100025	
TRC 80	100271060012	-	-	100051100025	

TRC



REF.	CODE 1	CODE 2	CODE 3	fig.
TRC 50	200100150501			1
TRC 63	100051050025	100051100020	100051100025	
TRC 80				
TRC 63	100051050016	201040607001	100051006020	2
TRC 80				

TRC

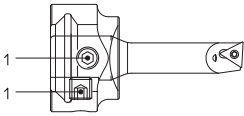


REF.	CODE 1	CODE 2	CODE 3
TRC 32 HS	100271050006	-	100231050008 100231050012
TRC 50 HS	100271060008	200560116082	100231100010
TRC 50			
TRC 63			
TRC 80	100271060012	-	100231060006



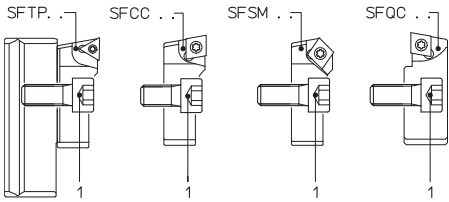
- SPARE PARTS
- ERSATZTEILE
- PIEZAS DE RECAMBIO
- PIÈCES ETACHÉES
- PARTI DI RICAMBIO

P 20.30



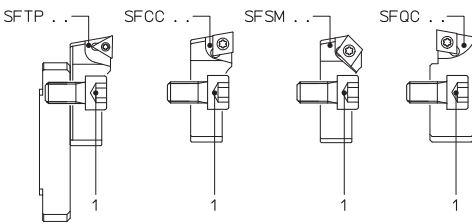
REF.	CODE 1
P20.30	100251080008

PS



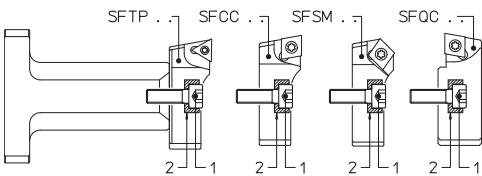
REF.	CODE 1
PS 11.30	100051100018
PS 12.30	
PS 13.30	
PS 11.40	100051100025
PS 12.40	
PS 13.40	
PS 14.40	

PS



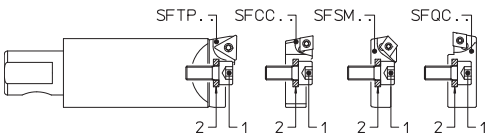
REF.	CODE1
PS31.24	100051100020
PS31.28	100051100025
PS32.28	
PS33.28	

P 22.28



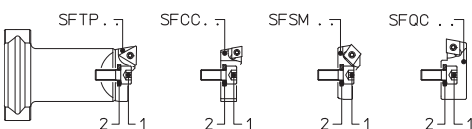
REF.	CODE 1	CODE 2
P22.28	100051060020	201040607001

P 25



REF.	CODE 1	CODE 2
P25.63	100051050012	100800100530
P25.105		

P

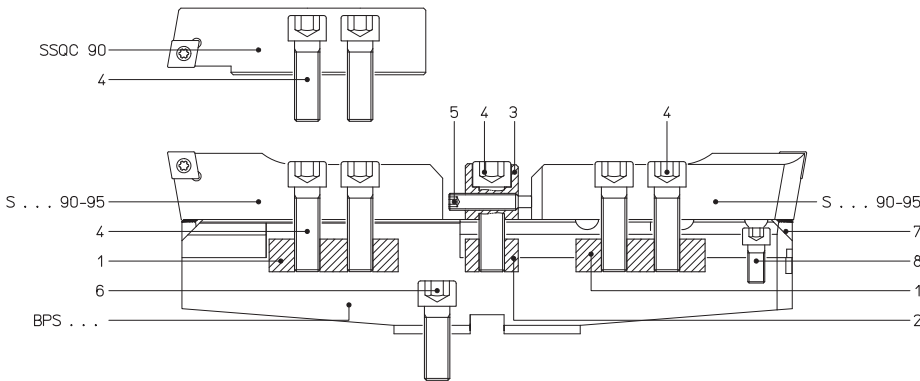


REF.	CODE 1	CODE 2
P 00.30	100051050012	100800100530
P 03.30		
P 04.30		
P 02.40	100051060018	100800100640
P 03.40		
P 04.40		



- SPARE PARTS
- ERSATZTEILE
- PIEZAS DE RECAMBIO
- PIÈCES ETACHÉES
- PARTI DI RICAMBIO

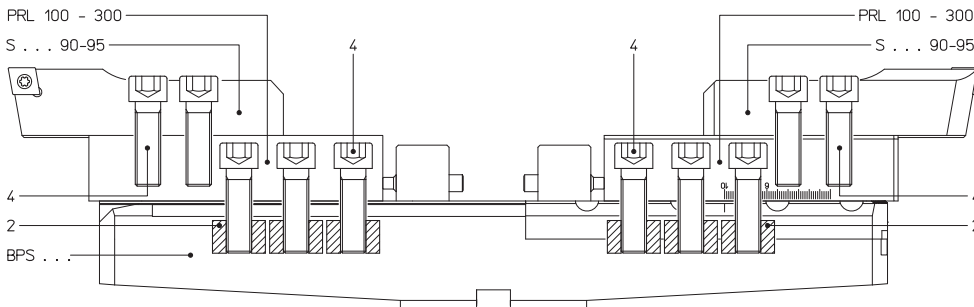
## BPS



REF.	CODE 1	CODE 2	CODE 3	CODE 4
BPS 200-300-400	201430110017	201430110016	201100502601	100051120040
BPS 500-600-700-800				
BPS 1000-1150-1600 GD				

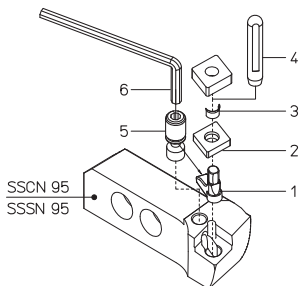
REF.	CODE 5	CODE 6	CODE 7	CODE 8
BPS 200	100251080040	100051120035	200655015707	100051080025
BPS 300			200655015708	
BPS 400		100051160050	200655016301	100051080020
BPS 500-600-700-800				100051080025
BPS 1000-1150-1600 GD				100051080030
BPS 1600 GD		100051200060		

## BPS + PRL 100 - 300



REF.	CODE 2	CODE 4
BPS 200-300-400	201430110016	100051120040
BPS 500-600-700-800		
BPS 1000-1150-1600 GD		

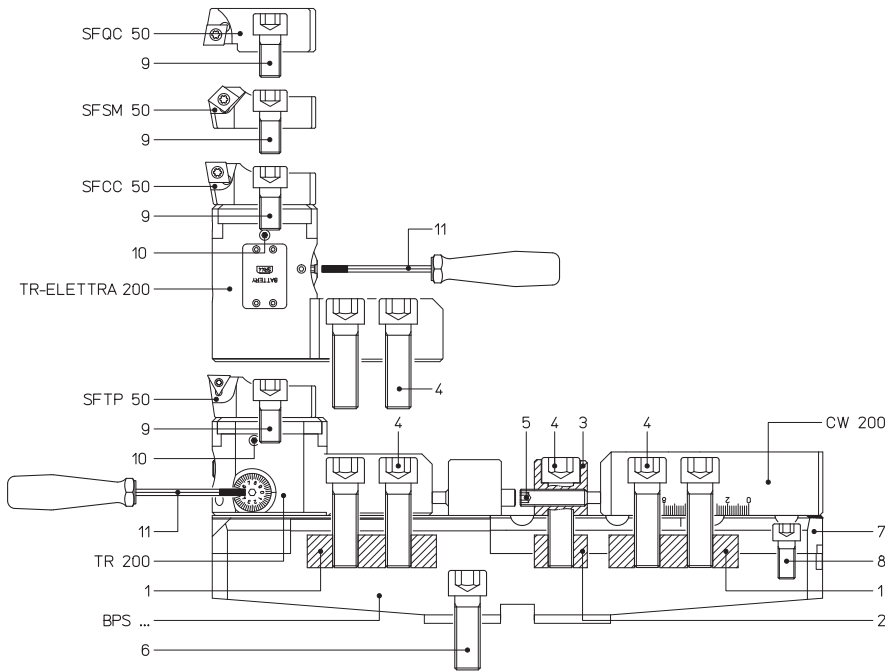
## SS 95



REF.	CODE 1	CODE 2	CODE 3	CODE 4	CODE 5	CODE 6
SSCN 95	491111190600	492031190600	100655095112	101501301408	494311190600	101500100400
SSSN 95		492035190600				



- SPARE PARTS
- ERSATZTEILE
- PIEZAS DE RECAMBIO
- PIÈCES ETACHÉES
- PARTI DI RICAMBIO

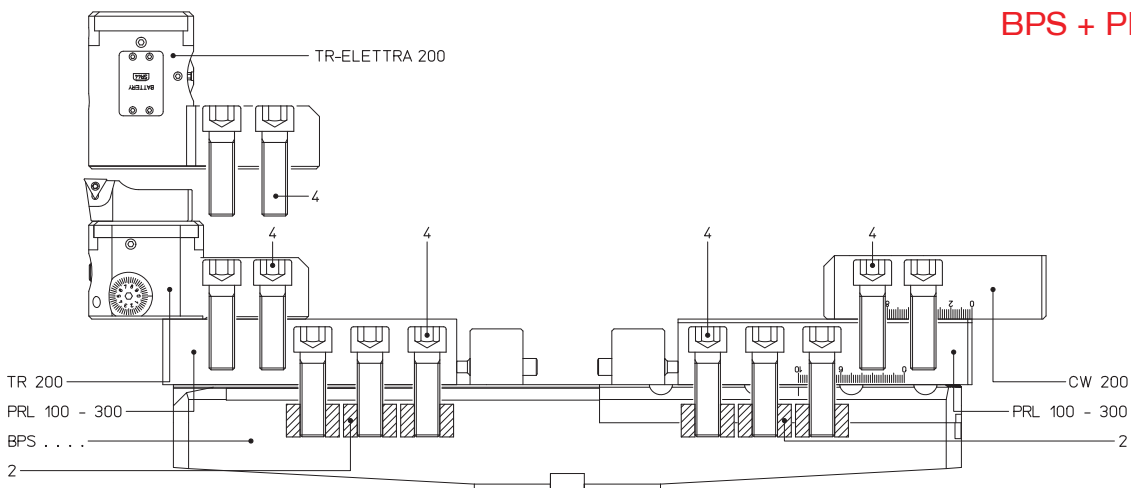


REF.	CODE 1	CODE 2	CODE 3	CODE 4	CODE 5
BPS 200-300-400	201430110017	201430110016	201100502601	100051120040	100251080040
BPS 500-600-700-800					
BPS 1000-1150-1600 GD					

REF.	CODE 6	CODE 7	CODE 8
BPS 200	100051120035	200655015707	100051080025
BPS 300		200655015708	
BPS 400		200655016301	100051080020
BPS 500-600-700-800			100051080025
BPS 1000-1150-1600 GD			100051080030
BPS 1600 GD			

REF.	CODE 9	CODE 10	CODE 11
BPS 200-300-400	100051100020	100251060008	101500800300
BPS 500-600-700-800			
BPS 1000-1150-1600 GD			

BPS + PRL 100 - 300



REF.	CODE 2	CODE 4
BPS 200-300-400	201430110016	100051120040
BPS 500-600-700-800		
BPS 1000-1160-1600 GD		

- CHUCKING TOOLS
- ADAPTER
- ADAPTADORES
- ADAPTATEURS
- ADATTATORI



**GB** Complete program of modular chucking tools with MHD' arbor that meets several milling, drilling and tapping needs.

**D** Das gesamte Programm modularer Adapter D'Andrea mit MHD'-Integralanschluss, das verschiedenen Fräs-, Bohr-, und Gewindebohrarbeiten gerecht wird.

**E** El programa completo de adaptadores modulares D' Andrea con unión MHD', satisface varias exigencias de elaboración en fresado, roscado y taladrado.

**F** La gamme complète d'adaptateurs modulaires D'Andrea avec mandrin MHD', répondant aux exigences d'usinage les plus variées en matière de fraisage, forage et taraudage.

**I** Il completo programma di adattatori modulari D'Andrea con attacco MHD', che soddisfa svariate esigenze di lavorazione in fresatura, foratura e maschiatura.



- INDEX
- INHALTSVERZEICHNIS
- ÍNDICE
- INDEX
- INDICE

## GB CHUCKING TOOLS

- PE.** Collet chucks to DIN 6499 - ER 11, ER 16, ER 20, ER 25, ER 32, ER 40.  
**MHD' FORCE.** Ultra-light toolholder FORCE.  
**AW.** Combi-toolholders Weldon (DIN 1835 B) and Whistle Notch (DIN 1835 E).  
**PF.** Universal milling cutter-holders for disc cutters and facing cutters.  
**CM.** Toolholders with internal morse taper for tools with thread to DIN 228-A and tang to DIN 228-B.  
**AM.** Tapping chuck holders for high production thread cutting.  
**B16.** Drill chuck-holders with internal taper B16 to DIN 238.  
**NS.** Semi-finished toolholders for special tools with hardened and ground.  
**ACR/NC.** Coolant chucking tools NC.  
**ACR.** Coolant chucking tools

## D SPANNZEUGE

- PE.** Spannzangenfutter nach DIN 6499 - ER 11, ER 16, ER 20, ER 25, ER 32, ER 40.  
**MHD' FORCE.** Spannzangenfutter mit hochfester Werkzeugschraubung.  
**AW.** Werkzeugaufnahme für Weldon (nach DIN 1835-B) und Whistle Notch (nach DIN 1835-E).  
**PF.** Kombiaufsteckfräsdorne für Scheibenfräser und Planfräser.  
**CM.** Werkzeugaufnahmen mit Morseinnenkegel für Werkzeuge mit Rückzuggewinde nach DIN 228-A und Lappen nach DIN 228-B.  
**AM.** Gewindeschneidspannfutter für höchste Beanspruchung in der Serienfertigung.  
**B16.** Bohrerfutteraufnahme mit Innenkegel B16 nach DIN 238.  
**NS.** Werkzeugaufnahmenrohlinge mit gehärtetem.  
**ACR/NC.** Spannzeuge für Kühlmittel NC.  
**ACR.** Aufnahme mit Kühlmittelübergabe.

## E ADAPTADORES

- PE.** Adaptadores portapinzas elásticas DIN 6499 - ER 11, ER 16, ER 20, ER 25, ER 32, ER 40.  
**MHD' FORCE.** Adaptadores de gran apriete FORCE.  
**AW.** Adaptadores combinados Weldon (DIN 1835 B) y Whistle Notch (DIN 1835 E).  
**PF.** Adaptadores portafresas combinados para fresas a disco y de planear.  
**CM.** Adaptadores combinados para cono morse con agujero roscado DIN 228-A y con uña DIN 228-B.  
**AM.** Adaptadores para roscar para alta producción.  
**B16.** Adaptadores para mandrinos portabrocas con acoplamiento B16 DIN 238.  
**NS.** Adaptadores semielaborados para herramientas especiales.  
**ACR/NC.** Adaptadores para líquido refrigerante NC.  
**ACR.** Adaptadores para líquido refrigerante

## F ADAPTATEURS

- PE.** Adaptateurs porte-pinces DIN 6499 - ER 11, ER 16, ER 20, ER 25, ER 32, ER 40.  
**MHD' FORCE.** Adaptateurs à serrage fort FORCE.  
**AW.** Adaptateurs combinés Weldon (DIN 1835 B) et Whistle Notch (DIN 1835 E).  
**PF.** Adaptateurs porte-fraises combinés pour fraises à disque et fraises à surfacer.  
**CM.** Adaptateurs avec cône morse pour outils avec filetage DIN 228-A et tenon DIN 228-B.  
**AM.** Adaptateurs de taraudage pour forte fabrication en série.  
**B16.** Adaptateurs pour mandrins porte-forets avec filetage B16 DIN 238.  
**NS.** Adaptateurs semi-finis pour outils spéciaux.  
**ACR/NC.** Adaptateurs pour liquide d'arrosage NC.  
**ACR.** Adaptateurs pour liquide d'arrosage.

## I ADATTATORI

- PE.** Adattatori portapinzas elastiche DIN 6499 - ER 11, ER 16, ER 20, ER 25, ER 32, ER 40.  
**MHD' FORCE.** Adattatori a forte serraggio FORCE.  
**AW.** Adattatori combinati Weldon (DIN 1835 B) e Whistle Notch (DIN 1835 E).  
**PF.** Adattatori portafrese combinati per frese a disco e spianare.  
**CM.** Adattatori combinati per cono morse con foro filettato DIN 228-A e con dente DIN 228-B.  
**AM.** Adattatori di maschiatura per forte produzione.  
**B16.** Adattatori per mandrini portapunte con attacco B16 DIN 238.  
**NS.** Adattatori semilavorati per utensili speciali.  
**ACR/NC.** Adattatori per liquido refrigerante NC.  
**ACR.** Adattatori per liquido refrigerante.

p. 130 • PE



p. 130 • MHD FORCE



p. 131 • AW



p. 132 • PF



p. 133 • CM



p. 134 • AM



p. 134 • B16



p. 134 • NS



p. 135 • ACR/NC



p. 135 • ACR

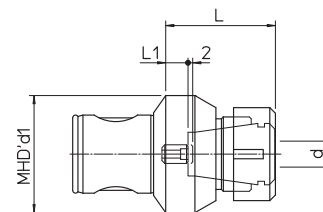


- CHUCKING TOOLS
- ADAPTER
- ADAPTADORES
- ADAPTATEURS
- ADATTATORI



- COLLETS CHUCKING TOOLS
- SPANNZANGENFUTTER
- ADAPTADORES PARA PINZAS ELÁSTICAS
- ADAPTATEURS POUR PINCES DE SERRAGE
- ADATTATORI PER PINZE ELASTICHE

ER DIN 6499

PE

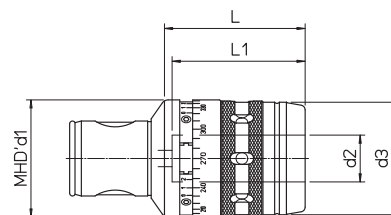


- Supplied without collets and clamping wrenches
- Ohne Spannzangen und Spannschlüssel.
- Pinzas elásticas y llaves de apriete excluidas
- Sans pinces et clés de serrage
- Pinze elastiche e chiavi di serraggio escluse

REF.	CODE	MHD' d <sub>1</sub>	d	L	L <sub>1</sub>	kg			N·m			
PE 16 / ER11M	655701600110	16	0.5 ~ 7	25	2.5	0.03	ER-11M	E11M	30			
PE 20 / ER16M	655702000160	20	0.5 ~ 10	32	1	0.06	ER-16M	E16M	40			
PE 25 / ER20M	655702500200	25	1 ~ 13	40	2.5	0.15	ER-20M	E20M	80			
PE 32 / ER25M	655703200250	32	1 ~ 16	42	1.5	0.25	ER-25M	E25M	160			
PE 40 / ER25	655704000250	40		45	5	0.4				UM/ER25	E25	200
PE 50 / ER25	655705000250	50		48	7	0.7				UM/ER25	E25	200
PE 50 / ER32	655705000320		63	55	8	1	UM/ER32	E32	220			
PE 63 / ER32	655706300320	63		2 ~ 20	59	12	1.3	UM/ER32	E32	220		
PE 63 / ER40	655706300400		3 ~ 26	64	1.5						UM/ER40	E40

- ULTRA-TIGHT TOOLHOLDER FORCE
- FORCE SPANNZANGENFUTTER MIT HOCHFESTER WERKZEUGSPANNUNG
- ADAPTADORES DE GRAN APRIETE FORCE
- ADAPTATEURS À SERRAGE FORT FORCE
- ADATTATORI A FORTE SERRAGGIO FORCE

MHD' FORCE



- Supplied without collets and clamping wrenches
- Ohne Spannzangen und Spannschlüssel.
- Pinzas elásticas y llaves de apriete excluidas
- Sans pinces et clés de serrage
- Pinze elastiche e chiavi di serraggio escluse

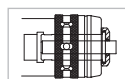
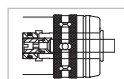
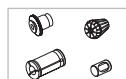
REF.	CODE	MHD' d <sub>1</sub>	d <sub>2</sub>	d <sub>3</sub>	L	L <sub>1</sub>	kg
FORCE 50/20 HS	656305000205	50	20	48	60	60	1
FORCE 63/32 HS	656306300325	63	32	66	80	80	2

120-136

241-242

222

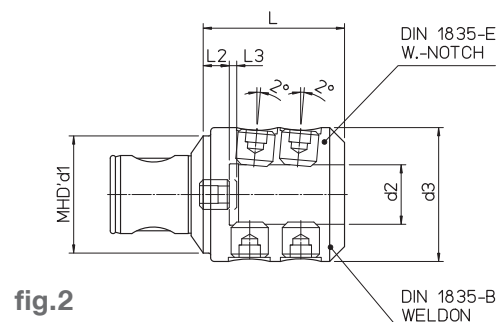
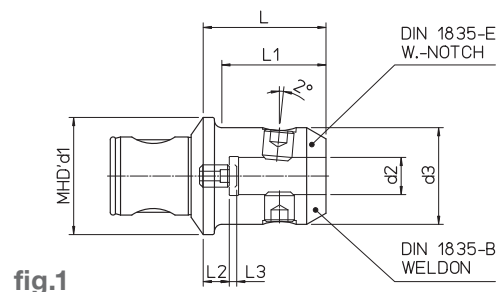
222



- CHUCKING TOOLS
- ADAPTER
- ADAPTADORES
- ADAPTATEURS
- ADATTATORI

- WELDON WHISTLE NOTCH CHUCKING TOOLS
- WELDON / WHISTLE NOTCH WERKZEUGAUFNAHMEN
- ADAPTADORES WELDON WHISTLE NOTCH
- ADAPTATEURS WELDON WHISTLE NOTCH
- ADATTATORI WELDON WHISTLE NOTCH

DIN 1835 B-E  
AW



REF.	CODE	MHD' d1	d2 <sup>H5</sup>	d3	L	L1	L2	L3	kg	fig.
AW 50/6	655805000060	50	6	25	44	32.5	7	2	0.5	1
AW 50/8	655805000080		8	28		33				
AW 50/10	655805000100		10	35	52	42	11	3	0.7	
AW 50/12	655805000120		12	42	57	48				
AW 50/14	655805000140		14	48	67	61	17	4	1.1	
AW 50/16	655805000160		16	51					67	
AW 50/20	655805000200		20	63	80	-	22	1.8	2	
AW 50/25	655805000250		25	63	80	-	22	1.8	2	
AW 63/16	655806300160	63	16	48	64	53	14	4	1.4	1
AW 63/20	655806300200		20	52	66	56			14	
AW 63/25	655806300250		25	64	74	-	16	2.1	2	
AW 63/32	655806300320		32	72	76		14	2.5		
AW 80/40	655808000400	80	40	80	83	-	12	3.2		





- CHUCKING TOOLS
- ADAPTER
- ADAPTADORES
- ADAPTATEURS
- ADATTATORI

- DISC AND FACING CUTTER HOLDERS
- SCHEIBEN- UND PLANFRÄSERAUFSTECKDORNE
- ADAPTADORES PARA FRESAS A DISCO Y DE PLANEAR
- ADAPTATEURS POUR FRAISES À DISQUE ET À SURFACER
- ADATTATORI PER FRESE A DISCO E A SPIANARE

PF

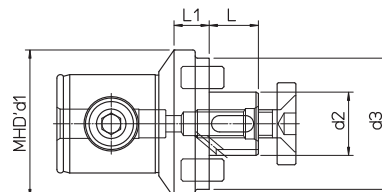
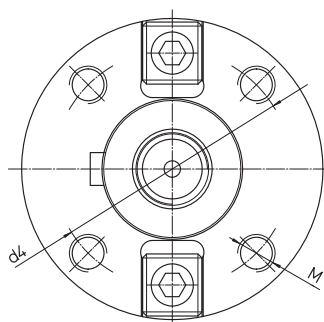
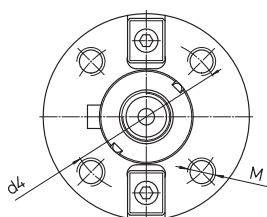


fig.1

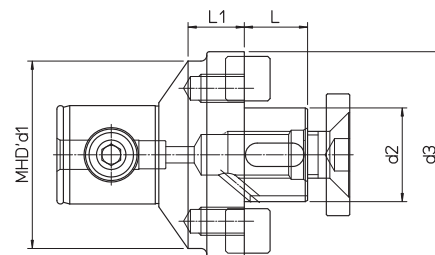


fig.2

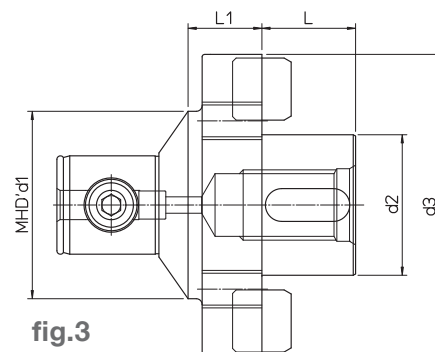


fig.3

REF.	CODE	MHD' d1	d2	d3	d4	M	L	L1	kg	fig.
PF 40/16	655904020165	40	16	32	-	-	17	15	0.3	1
PF 40/22	655904020225		22	40			19	13	0.4	
PF 50/16	655905000160	50	16	32			17	15	0.5	
PF 50/22	655905000220		22	40			19		0.6	
PF 50/27	655905000270		27	50			21		0.7	
PF 50/32	655905000320		32	60			24		0.9	
PF 63/22	655906300220	63	22	60			19	24	1.1	
PF 63/27	655906300270		27	63			21		1.2	
PF 63/32	655906300320		32	80			24		1.7	
PF 80/32	655908000320	80	32	80			66.7	M12	27	
PF 80/40	655908000400		40	84	-	-	30	2.0		
PF 80/50	655908000500		50	90	101.6	M16	40	31.5	3.5	3
PF 80/60	655908000600		60	128.5	101.6	M16	40	36	6	
PF 110/40	655911000400	110	40	88	66.7	M12	27	20	4.2	2
PF 110/60	655911000600		60	128.5	101.6	M16	40	36	6	
PF 140/40	655914000400	140	40	88	66.7	M12	27	26	6.2	2
PF 140/60	655914000600		60	140	101.6	M16	40		7.8	

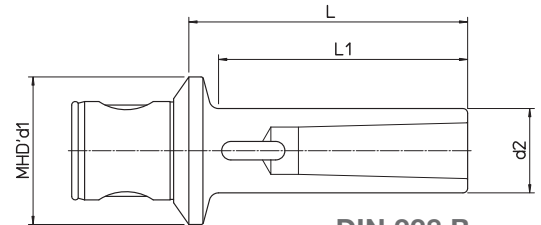


- CHUCKING TOOLS
- ADAPTER
- ADAPTADORES
- ADAPTATEURS
- ADATTATORI

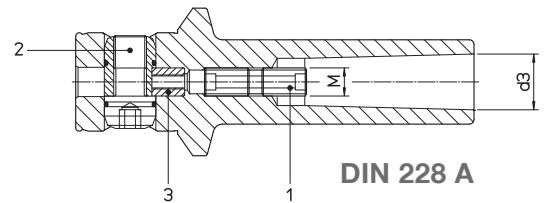
- MORSE TAPER CHUCKING TOOLS
- MORSEKEGELAUFNAHMEN
- ADAPTADORES PARA CONO MORSE
- ADAPTATEURS POUR CÔNE MORSE
- ADATTATORI PER CONO MORSE

DIN 228 A-B

CM



DIN 228 B



DIN 228 A

REF.	CODE	MHD' d <sub>1</sub>	MORSE	d <sub>2</sub>	d <sub>3</sub>	L	L <sub>1</sub>	M	kg
CM 50/1	656005000010	50	1	20	12.065	80	68	M6	0.6
CM 50/2	656005000020		2	30	17.780	100	86	M10	0.7
CM 50/3	656005000030	63	3	36	23.825	120	110	M12	1
CM 63/3	656006300030		4	48	31.267		108		1.3
CM 63/4	656006300040					150	133	M16	2

**GB MT DIN 228-A.** To chuck a morse taper tool with thread proceed as follows:

a. Drive in screw 1; b. Remove expanding pin 2 and sleeve 3 to allow the Allen wrench to be introduced from the rear; c. Fit the tool and tighten screw 1 clockwise; d. Reassemble expanding pin 2 and sleeve 3.

**MT DIN 228-B.** To chuck a morse taper tool with tang remove screw. 1. Combi-chucking tools for morse taper with DIN 228-A thread bore and with DIN 228-B tooth.

**D MK DIN 228-A.** Zum Einspannen eines Morsekegelwerkzeuges mit Rückzuggewinde folgendermaßen vorgehen:

a. Schraube 1 eindrehen; b. Spreizbolzen 2 und Buchse 3 entfernen, um den Sechskantschlüssel von hinten einführen zu können; c. Werkzeug einsetzen und Schraube 1 im Uhrzeigersinn festziehen; d. Buchse 3 und Spreizbolzen 2 wieder einsetzen.

**MK DIN 228-B.** Zum Einspannen eines Morsekegelwerkzeuges mit Austreiberlappen Schraube 1 herausdrehen. Werkzeughalter mit Morseinnekegel für Werkzeuge mit Rückzuggewinde nach DIN 228-A und Austreiberlappen nach DIN 228-B.

**E CM DIN 228-A.** Para montar una herramienta con cono morse con agujero roscado se precisa:

a. Montar roscando completamente el tornillo 1; b. Quitar el perno expansible 2 y el casquillo 3 para permitir el paso posterior de la llave hexagonal; c. Montar la herramienta y roscar en sentido horario el tornillo 1; d. Montar otra vez el casquillo 3 y el perno expansible 2.

**CM DIN 228-B.** Antes de montar una herramienta con cono morse con uña de arrastre, se precisa quitar el tornillo 1. Adaptadores combinados para cono morse con agujero roscado DIN 228-A y con uña DIN 228-B.

**F CM DIN 228-A.** Pour monter un outil cône morse avec filetage procéder de cette façon:

a. Poser la vis 1; b. Enlever la tige expansible 2 et la douille 3 pour permettre le passage postérieur de la clef hexagonale; c. Monter l'outil et serrer la vis 1 dans le sens des aiguilles d'une montre; d. Remonter la tige 2 et la douille 3.

**CM DIN 228-B.** Avant de monter un outil cône morse avec tenon, enlever la vis 1. Adaptateurs combinés pour cône morse avec trou fileté DIN 228-A et avec dent DIN 228-B.

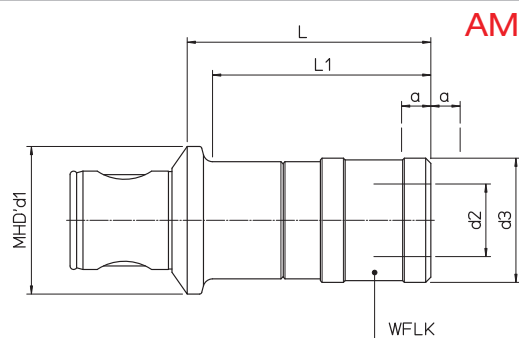
**I CM DIN 228-A.** Per montare un utensile a cono morse con attacco filettato occorre: a. Montare avvitando interamente la vite 1; b. Togliere il perno espandibile 2 e la bussola 3 per permettere il passaggio posteriore della chiave esagonale; c. Montare l'utensile e avvitare in senso orario la vite 1; d. Rimontare bussola 3 e perno espandibile 2.

**CM DIN 228-B.** Prima di montare un utensile a cono morse con tenone occorre togliere la vite 1. Adattatori combinati per cono morse con foro filettato DIN 228-A e con dente DIN 228-B.



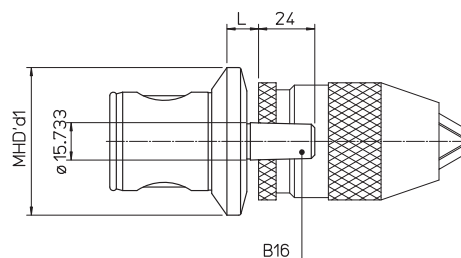
- CHUCKING TOOLS
- ADAPTER
- ADAPTADORES
- ADAPTATEURS
- ADATTATORI

- TAPPING CHUCK HOLDERS
- GEWINDESCHNEIDSPANNFUTTER
- ADAPTADORES PARA ROSCAR
- ADAPTATEURS DE TARAUDAGE
- ADATTATORI DI MASCHIATURA



REF.	CODE	MHD' d <sub>1</sub>	WFLK	Capacity	L	L <sub>1</sub>	d <sub>2</sub>	d <sub>3</sub>	a	kg
AM 50/M3-12	656505000100	50	WFLK 115B/A 308	M 3 ~ 12	72	60	19	36	7.5	0.9
AM 50/M8-20	656505000200		WFLK 225B/A 308	M 8 ~ 20	106	-	31	53	12.5	1.2
AM 63/M3-12	656506300100	63	WFLK 115B/A 308	M 3 ~ 12	70	58	19	36	7.5	1
AM 63/M8-20	656506300200		WFLK 225B/A 308	M 8 ~ 20	104	93	31	53	12.5	1.3

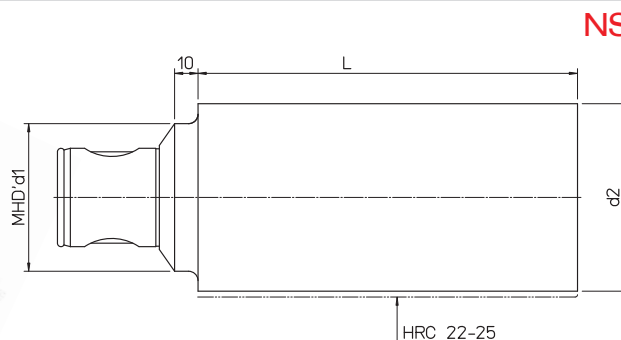
- DRILLING CHUCK HOLDERS B16 D238
- BOHRFUTTERAUFNAHME B16 D238
- ADAPTADORES PARA MANDRINOS B16 D238
- ADAPTATEURS POUR MANDRIN B16 D238
- ADATTATORI PER MANDRINO B16 D238



- Drilling chuck holders with B16 DIN 238 thread.
- Bohrfutteraufnahme mit Innenkegel B16 nach DIN 238.
- Adaptadores para mandrinos portabrocas con acoplamiento B16 DIN 238.
- Adaptateurs pour mandrin porte-forets avec cône B16 DIN 238.
- Adattatori per mandrini portapunte con attacco B16 DIN 238.

REF.	CODE	MHD' d <sub>1</sub>	L	kg
B 50/16	656105000160	50	10	0.4
B 63/16	656106300160	63	13.5	0.8

- SEMIFINISHED CHUCK HOLDERS
- WERKZEUGAUFNAHMERÖHLING
- ADAPTADORES SEMIELABORADOS
- ADAPTATEURS SEMI-FINIS
- ADATTATORI SEMILAVORATI



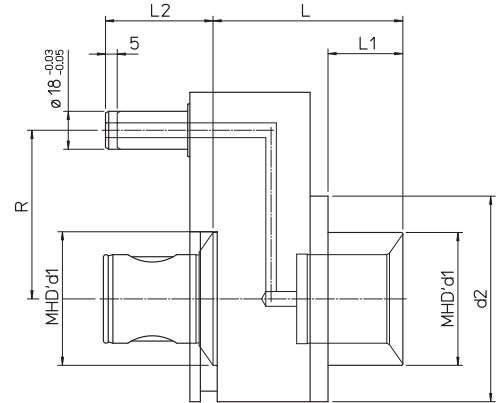
REF.	CODE	MHD' d <sub>1</sub>	d <sub>2</sub>	L	kg
NS 50	657205001600	50	63	160	4.2
NS 63	657206302000	63	80	200	8.7
NS 80	657208002500	80	100	250	16
NS 110	657211002500	110	130		18
NS 140	657214002500	140	150		30



- CHUCKING TOOLS
- ADAPTER
- ADAPTADORES
- ADAPTATEURS
- ADATTATORI

- COOLANT CHUCKING TOOLS NC
- AUFNAHME MIT KÜHLMITTELÜBERGABE NC
- ADAPTADORES PARA LÍQUIDO REFRIGERANTE NC
- ADAPTATEURS POUR LIQUIDE D'ARROSAGE NC
- ADATTATORI PER LIQUIDO REFRIGERANTE NC

ACR/NC

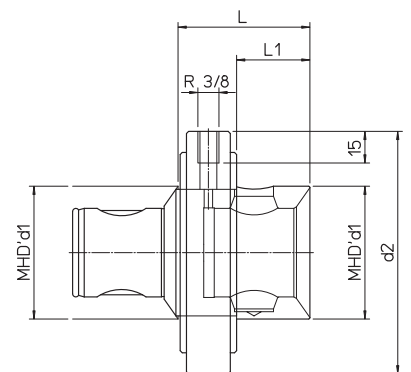


- **Important note.** Activate the coolant before the chuck rotation not to damage internal gaskets.
- **Wichtger Hinweis.** Das Kühlmittel vor der Spindelumdrehung einschalten, um die inneren Dichtungen nicht zu beschädigen.
- **Atención.** Accionar el líquido refrigerante antes de la ROTACIÓN del mandrino para preservar los retenes internos.
- **Note importante.** Actionner le liquide d'arrosage avant la ROTATION du mandrin afin de ne pas endommager les joints intérieurs.
- **Attenzione.** Azionare il liquido refrigerante prima della ROTAZIONE del mandrino per non danneggiare le guarnizioni interne.

REF.	CODE	MHD' d1	R	d2	L	L1	L2	RPM max	BAR	kg
ACR/NC 50/50	656705000501	50	65	80	72	28.5	43	7000	max 10	1.9
ACR/NC 50/50	656705000500		80							2.5
ACR/NC 63/63	656706300630	63	80	100	88	37	51	5600		5

- COOLANT CHUCKING TOOLS
- AUFNAHME MIT KÜHLMITTELÜBERGABE
- ADAPTADORES PARA LÍQUIDO REFRIGERANTE
- ADAPTATEURS POUR LIQUIDE D'ARROSAGE
- ADATTATORI PER LIQUIDO REFRIGERANTE

ACR



- **Important note.** Activate the coolant before the chuck rotation not to damage internal gaskets.
- **Wichtger Hinweis.** Das Kühlmittel vor der Spindelumdrehung einschalten, um die inneren Dichtungen nicht zu beschädigen.
- **Atención.** Accionar el líquido refrigerante antes de la ROTACIÓN del mandrino para preservar los retenes internos.
- **Note importante.** Actionner le liquide d'arrosage avant la ROTATION du mandrin afin de ne pas endommager les joints intérieurs.
- **Attenzione.** Azionare il liquido refrigerante prima della ROTAZIONE del mandrino per non danneggiare le guarnizioni interne.

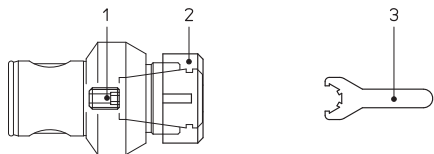
REF.	CODE	MHD' d1	d2	L	L1	RPM max	BAR	kg
ACR 63/63	656706310630	63	115	63	35	3500	max 10	2.9



- ACCESSORIES AND SPARE PARTS
- ZUBEHÖRTEILE UND ERSATZTEILE
- ACCESORIOS Y PIEZAS DE RECAMBIO
- ACCESSOIRES ET PIÈCES DETACHÉES
- ACCESSORI E PARTI DI RICAMBIO

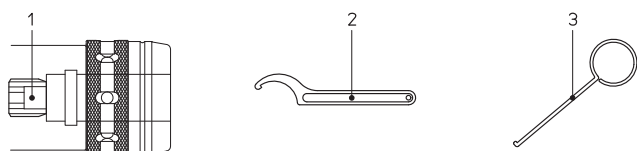
ER DIN 6499

PE



REF.	CODE 1	CODE 2	CODE 3
PE 16 / ER11M	200100190403	100451011100	101501001100
PE 20 / ER16M		100451011600	101501001600
PE 25 / ER20M	200100190506	100451012000	101501002000
PE 32 / ER25M	200100190608	100451012500	101501002500
PE 40 / ER25	200100190808	100451032500	101501002501
PE 50 / ER25			100451033200
PE 50 / ER32		101501003201	
PE 63 / ER32	200100191014	100451034000	101501004001
PE 63 / ER40	200100191214		

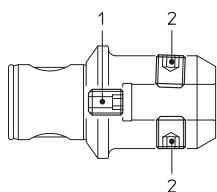
FORCE



REF	CODE 1	CODE 2	CODE 3
FORCE 12	200100191014	101500400028	201271600400
FORCE 20	200100191615	101500400050	
FORCE 32		101500400075	

DIN 1835 B-E

AW

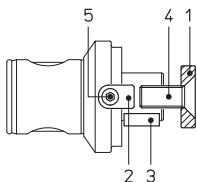


REF.	CODE 1	CODE 2
AW 50/6	200100190808	200100190610
AW 50/8		200100190810
AW 50/10		200100191012
AW 50/12		200100191216
AW 50/14	200100191215	200100191416
AW 50/16		200100191616
AW 50/20	200100191615	200100191820
AW 50/25	200100191215	200100191416
AW 63/16		200100191616
AW 63/20		200100191820
AW 63/25	200100191615	200100192020
AW 63/32		
AW 80/40	200100192019	



- ACCESSORIES AND SPARE PARTS
- ZUBEHÖRTEILE UND ERSATZTEILE
- ACCESORIOS Y PIEZAS DE RECAMBIO
- ACCESSOIRES ET PIÈCES DETACHÉES
- ACCESSORI E PARTI DI RICAMBIO

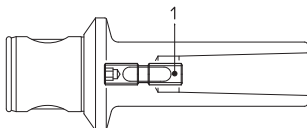
PF



REF.	CODE 1	CODE 2	CODE 3	CODE 4	CODE 5
PF 50/16 PF 40/16	201010085010	201101800801	101001040014	100101080025	100051030008
PF 50/22 PF 40/22	201010105030	201101801002	101001060016	100101100025	100051040010
PF 50/27	201010125030	201101801202	101001070018	100101120030	100051050012
PF 50/32	201010165020	201101801402	101001080020	100101160035	100051060016
PF 63/22	201010105030	201101801002	101001060016	100101100025	100051040010
PF 63/27	201010125030	201101801202	101001070018	100101120030	100051050012
PF 63/32	201010165020	201101801402	101001080020	100101160035	100051060016
PF 80/32					
PF 80/40	201010210010	201101801603	101001100025	100101200045	100051060018
PF 80/50	201010260330	201101801802	101001120028	100101240050	100051060020
PF 80/60	-	201101802510	101001140036	-	100051120025
PF 110/40	201010210010	201101801603	101001100025	100101200045	100051060018
PF 110/60	-	201101802510	101001140036	-	100051120025
PF 140/40	201010210010	201101801603	101001100025	100101200045	100051060018
PF 140/60	-	201101802510	-	-	100051120025

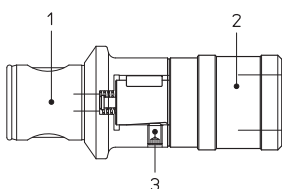
DIN 228 A

CM



REF.	CODE 1
CM 50/1	201081506003
CM 50/2	201081510002
CM 50/3	201081512004
CM 63/3	
CM 63/4	201081516001

AM



REF.	REF. 1	CODE 1	REF. 2	CODE 2	CODE 3
AM 50/M3-12	RAM 50/M3-12	456505000100	WFLK 115B/A 308	495090010312	100231060008
AM 50/M8-20	RAM 50/M8-20	456505000200	WFLK 225B/A 308	495090020820	100231080012
AM 63/M3-12	RAM 63/M3-12	456506300100	WFLK 115B/A 308	495090010312	100231060008
AM 63/M8-20	RAM 63/M8-20	456506300200	WFLK 225B/A 308	495090020820	100231080012





*PSC Modularity  
and high precision*



- ARBORS
- GRUNDAUFNAHMEN
- ACOPLAMIENTOS BASE
- MANDRINS
- ATTACCHI BASE

p.140 • **HSK-A / PSC**  
DIN 69893 / ISO 26623-2



p.140 • **DIN-AD / PSC**  
DIN 69871 / ISO 26623-2



p.140 • **DIN-AD+B / PSC**  
DIN 69871 / ISO 26623-2



p.141 • **CAT-AD+B / PSC**  
ANSI B5.50 / ISO 26623-2



p.141 • **BT / PSC**  
MAS 403 BT / ISO 26623-2



p.141 • **BT-AD+B / PSC**  
MAS 403 BT / ISO 26623-2



p.142 • **PSC - MHD'**  
ISO 26623-1



- EXTENSIONS REDUCTIONS
- VERLÄNGERUNGEN, REDUZIERUNGEN
- PROLONGACIONES REDUCCIONES
- RALLONGES-RÉDUCTIONS
- PROLUNGHE RIDUZIONI

p.143 • **PR / PSC**  
ISO 26623-1 / 2



p.143 • **RD / PSC**  
ISO 26623-1 / 2



p.149-153-157 • **SF. .**  
p.163-167-171



p.148-152-156-162 • **PS 31**



p.148-152-156-162 • **CW 32**



p.149-153-157 • **P25**  
p.163-167



p.153-157 • **P22**



p.165-169 • **P20.30**



p.166-170 • **PS**



p.167-171 • **P**



p.147-151-155 • **B. .**  
p.161-165-169



- TESTAROSSA

p.144-149 • **TR-E50 PSC 50** • **KIT K01**  
Ø 2.5-110 Ø 6 - 110



p.150-153 • **TR-E63 PSC 63** • **KIT K01**  
Ø 6 - 125 Ø 6 - 125



p.154-157 • **TR-E80 PSC 80** • **KIT K01**  
Ø 6 - 200 Ø 6 - 200



p.158-163 • **TR 50 PSC 40**  
• **TR 50 PSC 50**  
• **TR 50 PSC 63** • **KIT K01**  
Ø 2.5 - 108 Ø 6 - 108



p.164-167 • **TR 63 PSC 63** • **KIT K01**  
Ø 2.5 - 125 Ø 6 - 125



p.168-171 • **TR 80 PSC 80** • **KIT K01**  
Ø 2.5 - 160 Ø 6 - 220



p.172 • **PSC-PF**  
ISO 26623-1



p.179 • **PSC-MF** • **KIT K01**  
ISO 26623-1 ISO 26623-1



p.214-215 • **PSC 63-80 CT**  
ISO 26623-1

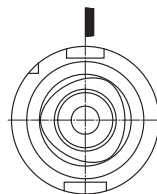


p.230 • **MCD' PSC**  
ISO 26623-1



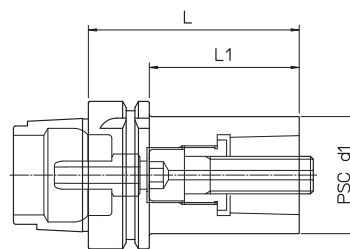
- ARBORS
- GRUNDAUFNAHMEN
- ACOPLAMIENTOS BASE
- MANDRINS
- ATTACCHI BASE

- Supplied with coolant tube
- Lieferung inklusive Kühlmittelrohr
- Completo con racor para el refrigerante
- Pourvu de raccord pour liquide d'arrosage
- Completo di raccordo per il refrigerante



### HSK-A / PSC

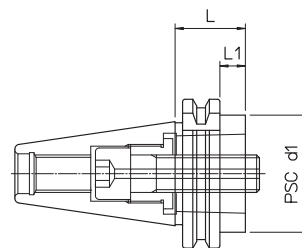
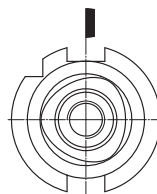
DIN 69893 / ISO 26623-2



HSK-A	REF.	CODE	PSC d1	L	L1	kg
63	HSK-A63 PSC 40.80	41PV04056320	40	80	54	1.1
	HSK-A63 PSC 50.90	41PV05056320	50	90	64	1.5
100	HSK-A100 PSC 50.100	41PV05059920	50	100	71	3
	HSK-A100 PSC 63.110	41PV06359920	63	110	81	3.6
	HSK-A100 PSC 80.120	41PV08059920	80	120	91	4.7
125	HSK-A125 PSC 80.130	41PV08059520	80	130	101	6.5

### DIN-AD / PSC

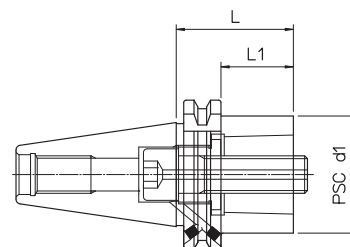
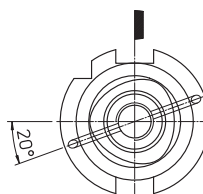
DIN 69871 / ISO 26623-2



DIN	REF.	CODE	PSC d1	L	L1	kg
40	DIN69871-A40 PSC 50.30	41PV05014020	50	30	11	0.8
50	DIN69871-A50 PSC 63.30	41PV06315020	63			2.5

### DIN-AD+B / PSC

DIN 69871 / ISO 26623-2

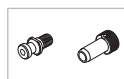


DIN	REF.	CODE	PSC d1	L	L1	kg
40	DIN69871-AD+B40 PSC 40.30	41PV04014021	40	30	11	0.8
	DIN69871-AD+B40 PSC 50.40	41PV05014029	50	40	21	0.9
	DIN69871-AD+B40 PSC 50.50	41PV05014021		50	31	1.1
50	DIN69871-AD+B50 PSC 50.30	41PV05015021	63	30	11	2.7
	DIN69871-AD+B50 PSC 63.30	41PV06315029		50	31	2.8
	DIN69871-AD+B50 PSC 63.50	41PV06315021	63		50	3
	DIN69871-AD+B50 PSC 80.70	41PV08015021	80	70	51	3.7

249-252

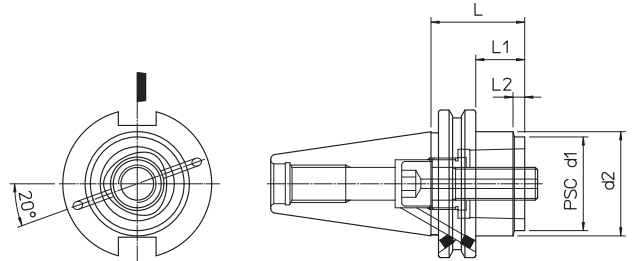
173

240



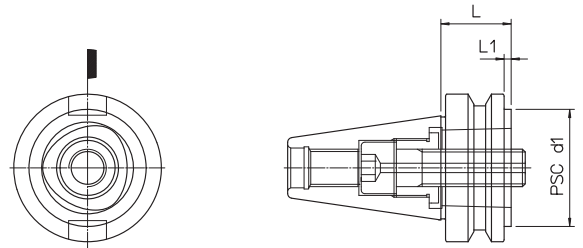
- ARBORS
- GRUNDAUFNAHMEN
- ACOPLAMIENTOS BASE
- MANDRINS
- ATTACCHI BASE

**CAT-AD+B / PSC**  
ANSI B5.50 / ISO 26623-2



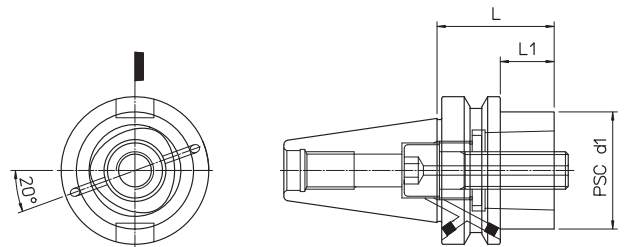
CAT	REF.	CODE	PSC d1	d2	L	L1	L2	M	kg
40	CAT40 AD+B PSC 40.40	41PV04014046	40	44.5	40	21	5	UNC 5/8-11	0.95
	CAT40 AD+B PSC 50.50	41PV05014046	50	-	50	31	-		1
50	CAT50 AD+B PSC 50.40	41PV05015046		63	69.9	40	21	5	UNC 1/8
	CAT50 AD+B PSC 63.50	41PV06315046	70		50	31	12.5	3	
	CAT50 AD+B PSC 80.100	41PV08015046	80	-	100	81	-	4.6	

**BT / PSC**  
MAS 403 BT / ISO 26623-2



BT	REF.	CODE	PSC d1	L	L1	kg
40	MAS403 BT40 PSC 50.30	41PV05014030	50	30	3	0.9
50	MAS403 BT50 PSC 63.40	41PV06315030	63	40	2	3.3

**BT-AD+B / PSC**  
MAS 403 BT / ISO 26623-2



BT	REF.	CODE	PSC d1	L	L1	kg
40	MAS403 BT40-AD+B PSC 40.30	41PV04014031	50	40	3	0.9
	MAS403 BT40-AD+B PSC 50.50	41PV05014031		50	23	1.2
50	MAS403 BT50-AD+B PSC 50.40	41PV05015031	63	40	2	3.4
	MAS403 BT50-AD+B PSC 63.50	41PV06315031		50	12	3.5
	MAS403 BT50-AD+B PSC 80.70	41PV08015031	80	70	32	4



- ARBORS
- GRUNDAUFNAHMEN
- ACOPLAMIENTOS BASE
- MANDRINS
- ATTACCHI BASE

PSC-MHD'  
ISO 26623-1

142

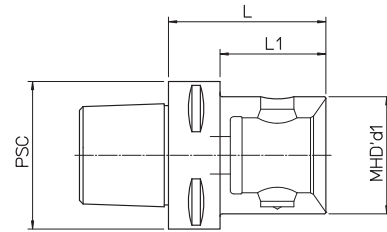


fig.1

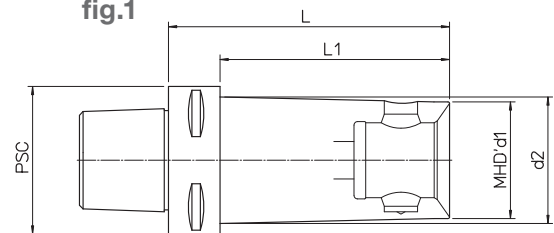


fig.2

PSC	REF.	CODE	MHD' d1	d2	L	L1	Kg.	fig.
40	PSC 40 - MHD' 32.42	416322604004	32	-	42	22	0.3	1
	PSC 40 - MHD' 40.45	416402604004	40		45	-	0.4	
50	PSC 50 - MHD' 50.55	416502605005	50	-	55	-	0.8	1
63	PSC 63 - MHD' 40.50	416402606305	40		44	50	28	
	PSC 63 - MHD' 40.120	416402606312	40	55		33	0.8	
	PSC 63 - MHD' 50.55	416502606305	50	-	67	45	1.1	1
	PSC 63 - MHD' 50.67	416502606306	50	54	120	98	1.9	2
	PSC 63 - MHD' 50.120	416502606312	50	-	77	-	1.8	1
	PSC 63 - MHD' 63.77	416632606307	63	-	77	-	1.8	
80	PSC 80 - MHD' 50.60	416502608006	50	54	60	30	2	2
	PSC 80 - MHD' 50.120	416502608012	50		60	30	2	
	PSC 80 - MHD' 63.70	416632608007	63	-	70	40	2.3	1
	PSC 80 - MHD' 63.150	416632608015	63	67	150	120	4	2
	PSC 80 - MHD' 80.75	416802608007	80	-	75	-	2.6	1
	PSC 80 - MHD' 80.120	416802608012	80		120	-	4.3	
100	PSC 100 - MHD' 80.80	416802610008	80	-	80	44	3.5	1
	PSC 100 - MHD' 110.120	416912610012	110		120	84	5	

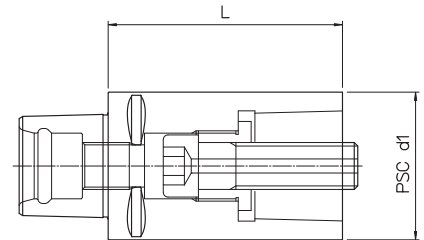


- EXTENSIONS
- VERLÄNGERUNGEN
- PROLONGACIONES
- RALLONGES
- PROLUNGHE



**PR PSC**  
ISO 26623-1 / 2

143

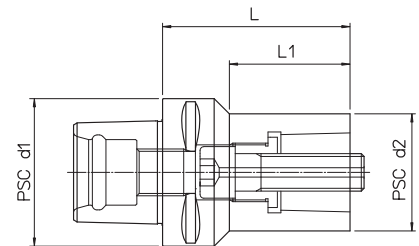


REF.	CODE	PSC d1	L	kg
PR PSC 32.60	656PV03206000	32	60	0.35
PR PSC 32.80	656PV03208000		80	0.45
PR PSC 40.60	656PV04006000	40	60	0.55
PR PSC 40.80	656PV04008000		80	0.7
PR PSC 40.100	656PV04010000		100	0.9
PR PSC 50.80	656PV05008000	50	80	1.1
PR PSC 50.100	656PV05010000		100	1.4
PR PSC 63.100	656PV06310000	63	100	2.2
PR PSC 63.140	656PV06314000		140	3.2
PR PSC 80.100	656PV08010000	80	100	3.6
PR PSC 80.125	656PV08012500		125	4.5

- REDUCTIONS
- REDUZIERUNGEN
- REDUCCIONES
- RÉDUCTIONS
- RIDUZIONI



**RD PSC**  
ISO 26623-1 / 2



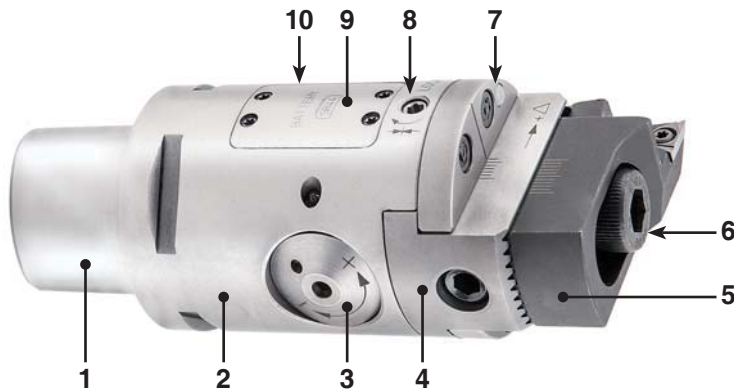
REF.	CODE	PSC d1	PSC d2	L	L1	kg
RD PSC 40/32.70	657PV04003200	40	32	70	12	0.6
RD PSC 50/32.60	657PV05003200			60	34.8	0.65
RD PSC 50/40.65	657PV05004000	50	40	65	45	0.7
RD PSC 50/40.85	657PV05004001			85	12	1
RD PSC 63/32.70	657PV06303200	63	32	70	39	1.1
RD PSC 63/40.80	657PV06304000		40	80	51.4	1.3
RD PSC 63/50.80	657PV06305000		50	80	51.5	1.5
RD PSC 63/50.110	657PV06305001			110	12	3.4
RD PSC 80/32.60	657PV08003200	80	32	60	29.3	1.8
RD PSC 80/40.70	657PV08004000		40	70	36.5	1.9
RD PSC 80/50.80	657PV08005000		50	80	49.3	2.2
RD PSC 80/63.80	657PV08006300		63	80	53.1	2.5
RD PSC 80/63.120	657PV08006301			120	12	3.9
RD PSC 100/80.100	657PV10008000	100	80	100	58.2	5

173

252







- 1 • PSC
- 2 • Body
- 3 • Set screw
- 4 • Slide toolholder
- 5 • Bit holder
- 6 • Tools clamp screws

- 7 • Coolant outlet
- 8 • Slide clamp screw
- 9 • Battery compartment cover
- 10 • Oiler

- 11 • Digital display
- 12 • Selection button

IP67

2 μm



TR-E 50 - PSC 50



TR-E 63 - PSC 63

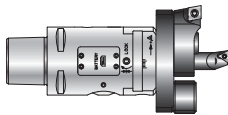


TR-E 80 - PSC 80



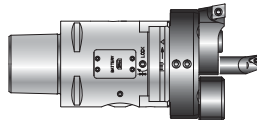
## TR-ELETTRA 50 PSC 50

Ø 2.5 ~ 110



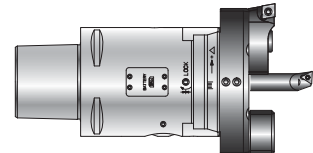
## TR-ELETTRA 63 PSC 63

Ø 6 ~ 125



## TR-ELETTRA 80 PSC 80

Ø 6 ~ 200



**GB FEATURES.** The TR-ELETTRA heads enable high precision machining with tolerance grade, IT6, with excellent surface finish. They have a 1 micron radius adjustment sensitivity on a built-in digital display, ensuring maximum speed and adjustment accuracy. The TR-ELETTRA heads are resistant to water infiltration and are coated with an anti-corrosive surface protection.

**D MERKMALE.** Die TR-ELETTRA-Köpfe ermöglichen hochpräzise Bearbeitungen mit IT6-Toleranzen und optimalem Oberflächenfinish. Ihre Einstellgenauigkeit liegt bei 1 Mikron an dem auf einem integrierten digitalen Display angezeigten Radius, was ein Maximum an Schnelligkeit und Einstellgenauigkeit gewährleistet. Die TR-ELETTRA-Köpfe sind gegen Eindringen von Wasser beständig und haben an der Oberfläche eine Antikorrosionsbeschichtung.

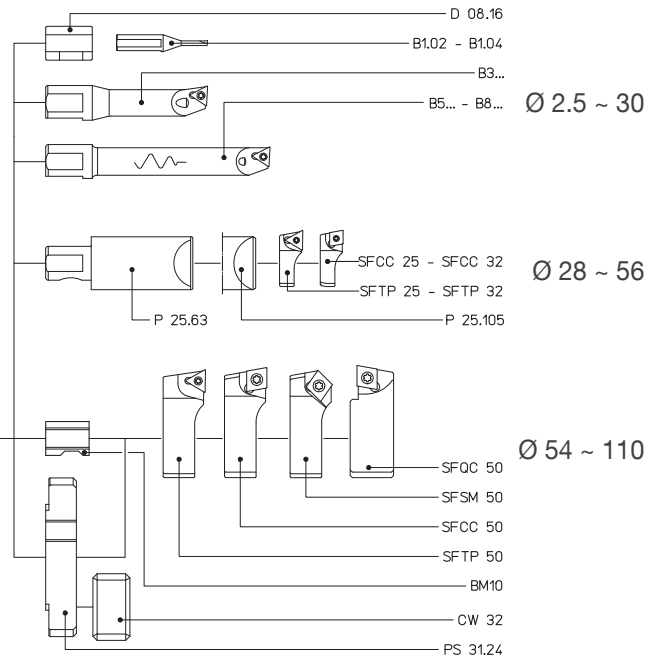
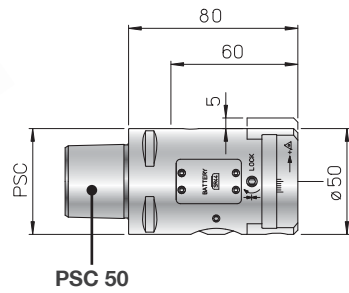
**E CARACTERÍSTICAS.** Los cabezales TR-ELETTRA ofrecen un mecanismo de alta presión para una tolerancia de grado IT6, con un excelente acabado superficial. Tienen una sensibilidad de ajuste de una 1 micra sobre el radio incorporado en la pantalla digital, garantizando la máxima velocidad y precisión de ajuste. Las cabezales TR-ELETTRA son resistentes a la infiltración del agua y están cubiertas con una protección anticorrosiva superficial.

**F CARACTÉRISTIQUES.** Les têtes TR-ELETTRA permettent des usinages de haute précision avec des tolérances de degré IT6, comprenant un excellent finissage superficiel. Elles ont une sensibilité de réglage de 1 micron sur le rayon visualisé sur un écran intégré, garantissant une vitesse et une précision de réglage maximale. Les têtes TR-ELETTRA résistent aux infiltrations d'eau et elles sont revêtues d'une protection superficielle anticorrosion.

**I CARATTERISTICHE.** Le testine TR-ELETTRA consentono lavorazioni di alta precisione in tolleranze di grado IT6, con ottima finitura superficiale. Hanno una sensibilità di regolazione di 1 micron sul raggio visualizzato su un display digitale incorporato, garantendo la massima velocità e precisione di regolazione. Le testine TR-ELETTRA sono resistenti alle infiltrazioni d'acqua e sono rivestite con una protezione superficiale anticorrosiva.



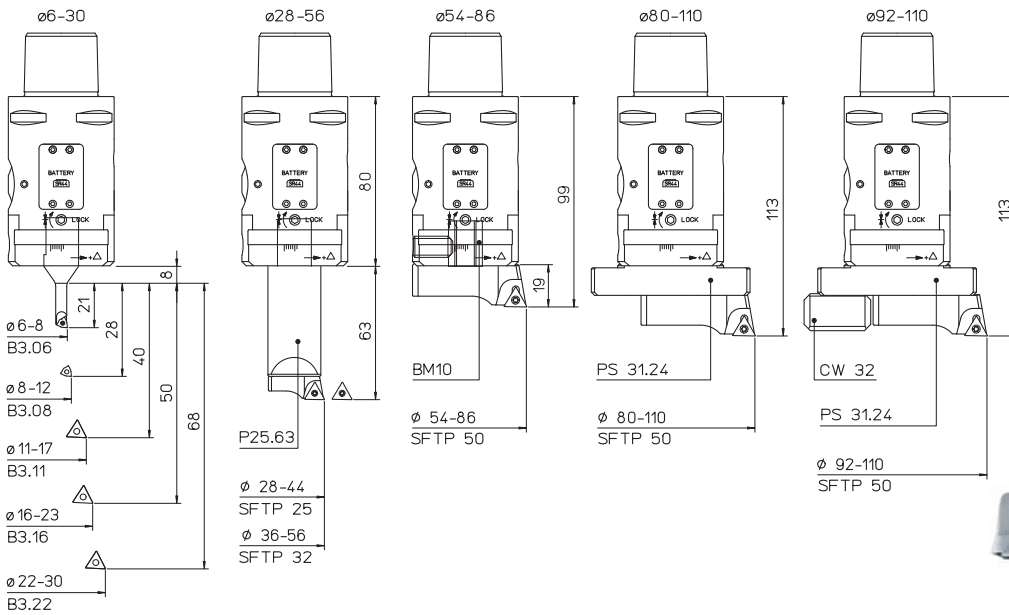
2  $\mu$ m



REF.	CODE	Kg.
TR-ELETTRA 50 PSC 50	455255026050	1.2

### KIT K01

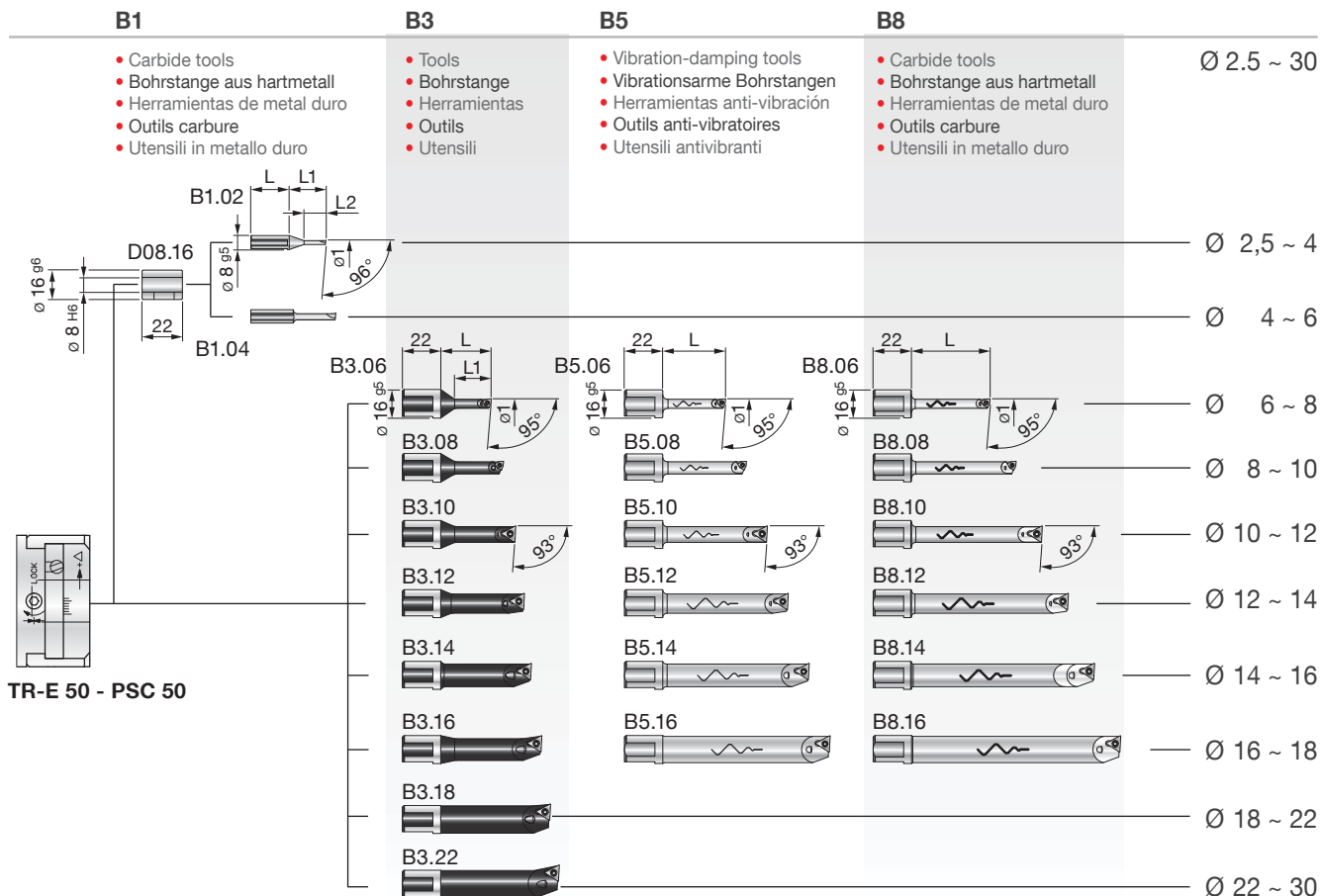
$\varnothing$  6 ~ 110



- 1 TR-ELETTRA 50 PSC 50
- 1 P25.63 1 B3.06 1 B3.22 5 TPGX 090202L DC100
- 1 BM10 1 B3.08 1 SFTP25 1 TPGX 110302L DC100
- 1 PS 31.24 1 B3.11 1 SFTP32 2 WCGT 020102L DC100
- 1 CW 32 1 B3.16 1 SFTP50

REF.	CODE	$\varnothing$
KIT K01 TR-ELETTRA 50 PSC 50	655255026050	6 ~ 110





REF.	CODE	Kg.
D08.16	200560116082	0.02

REF.	CODE	Ø1	L	L1	L2	Kg.
B1.02	572010502001	2.5 ~ 4	22	21	12.5	0.02
B1.04	572010504001	4 ~ 6	24	24	-	

REF.	CODE	Ø1	L	L1	⊖	⊖	⊖	⊖	Kg.
B3.06	572010506001	6 ~ 8	29	21	WCGT 0201..	-	TS 21	TORX T06	0.035
B3.08	572010508001	8 ~ 10	36	28			TS 211		0.04
B3.10	572010510001	10 ~ 12	43	35	-	TPGX 0902..	CS 250 T	TORX T08	0.05
B3.11	572010511001	11 ~ 13	48	40					0.055
B3.12	572010512001	12 ~ 14	42						0.06
B3.14	572010514001	14 ~ 16	52	50					0.07
B3.16	572010516001	16 ~ 18	58						
B3.18	572010518001	18 ~ 22	63						0.1
B3.22	572010522001	22 ~ 30	68						

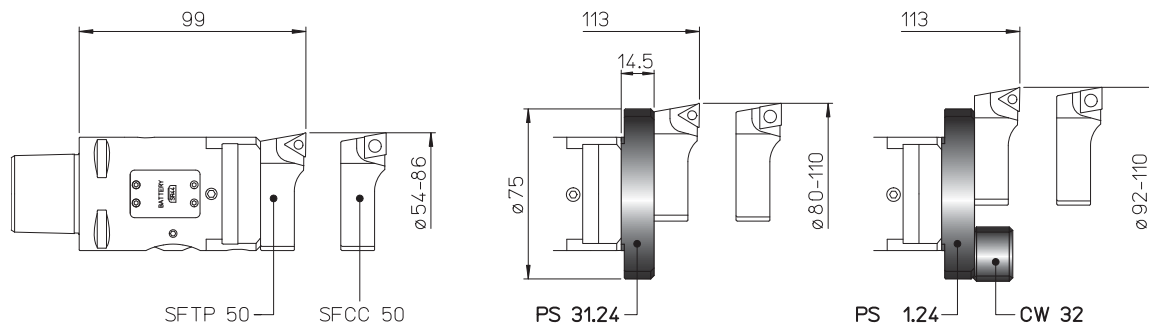
B5.06	572010506105	6 ~ 8	36		WCGT 0201..	-	TS 21	TORX T06	0.075
B5.08	572010508105	8 ~ 10	48				TS 211		0.09
B5.10	572010510105	10 ~ 12	60		-	TPGX 0902..	CS 250 T	TORX T08	0.1
B5.12	572010512105	12 ~ 14	72						0.2
B5.14	572010514105	14 ~ 16	84						0.3
B5.16	572010516105	16 ~ 18	96						

B8.06	572010506108	6 ~ 8	45		WCGT 0201..	-	TS 21	TORX T06	0.065
B8.08	572010508108	8 ~ 10	60				TS 211		0.08
B8.10	572010510108	10 ~ 12	75		-	TPGX 0902..	CS 250 T	TORX T08	0.1
B8.12	572010512108	12 ~ 14	90						0.2
B8.14	572010514108	14 ~ 16	105						0.3
B8.16	572010516108	16 ~ 18	120						

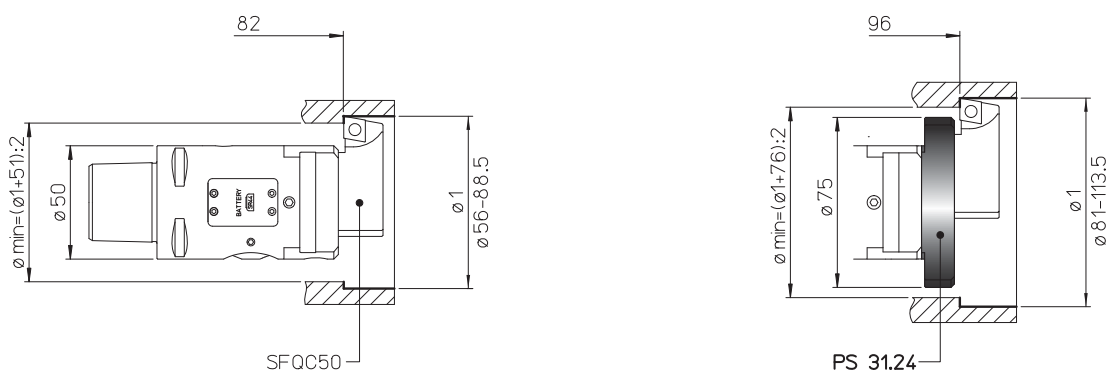
#### PSC 50 ISO 26623-1

- TOOLHOLDERS FOR TESTAROSSA
- WERKZEUGE FÜR TESTAROSSA
- PORTAHERRAMIENTAS PARA TESTAROSSA
- PORTE-OUTILS POUR TESTAROSSA
- PORTAUTENSILI PER TESTAROSSA

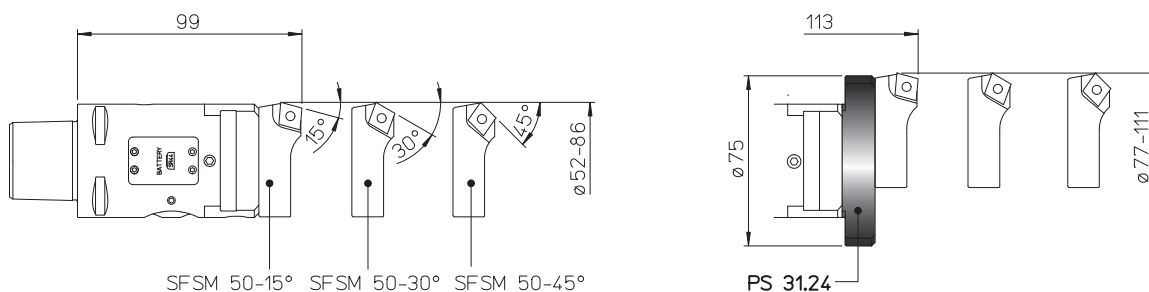
**PS 31**  
**CW 32**  
 $\varnothing 54 \sim 110$



**PS 31**  
 $\varnothing 56 \sim 113.5$



**PS 31**  
 $\varnothing 52 \sim 111$

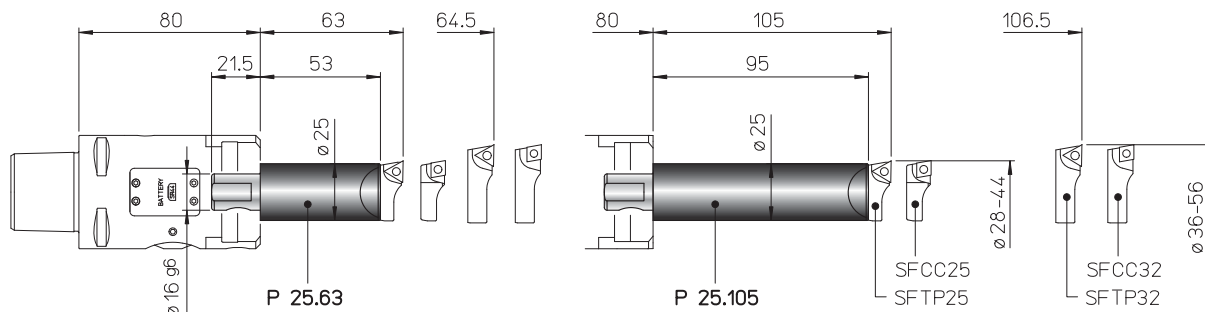


REF.	CODE	Kg.
PS 31.24 TR..50	433024140751	0.19
CW 32	392011003201	0.07



- TOOLHOLDERS FOR TESTAROSSA
- WERKZEUGE FÜR TESTAROSSA
- PORTAHERRAMIENTAS PARA TESTAROSSA
- PORTE-OUTILS POUR TESTAROSSA
- PORTAUTENSILI PER TESTAROSSA

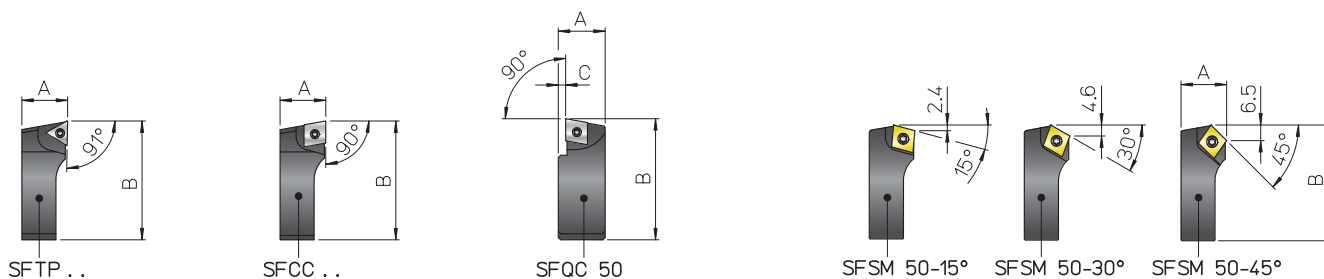
P 25  
Ø 28 ~ 56



REF.	CODE	Kg.
P25.63 TR...	435116250631	0.5
P25.105 TR...	435116251051	0.8

- BIT-HOLDERS FOR TESTAROSSA
- PLATTENHALTER FÜR TESTAROSSA
- PORTA-PLAQUITAS PARA TESTAROSSA
- PORTE-PLAQUETTES POUR TESTAROSSA
- SEGGI PER TESTAROSSA

SF



REF.	CODE	A	B	C	△	□	⌋	⌋	Kg.
SFTP 25	470500525001	10	26.5	-	TPGX 0902..	-	CS 250T	TORX T08	0.01
SFTP 32	470500532001	11.5	34.5	-	-	-	0.02		
SFTP 50	470500550001	19	52	-	TPGX 1103..	-	CS 300890T		0.08
SFCC 25	470500525002	10	26.5	-	-	CCGT 0602..	TS 25	TORX T08	0.01
SFCC 32	470500532002	11.5	34.5	-	-	-	-	TORX T08	0.02
SFCC 50	470500550002	19	52	-	-	CCGT 09T3..	TS 4	TORX T15	0.08
SFQC 50	470500550062	20.5	53	3	-	CCMT 09T3..	TS 4	TORXT15	0.1
SFSM 50-15°	470500550011	19	50.5	-	-	CCMT 09T3..	TS 4	TORXT15	0.07
SFSM 50-30°	470500550013								
SFSM 50-45°	470500550015								

116

175

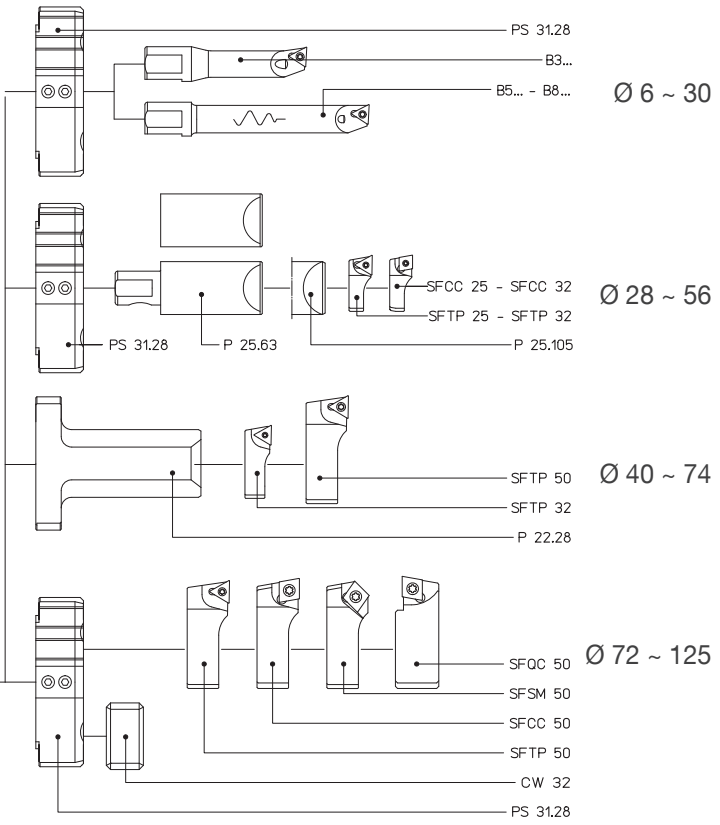
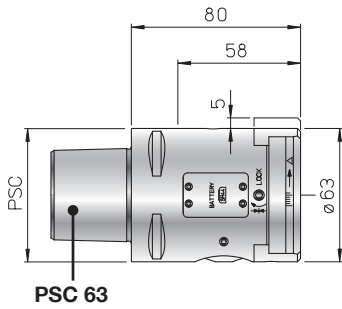
119



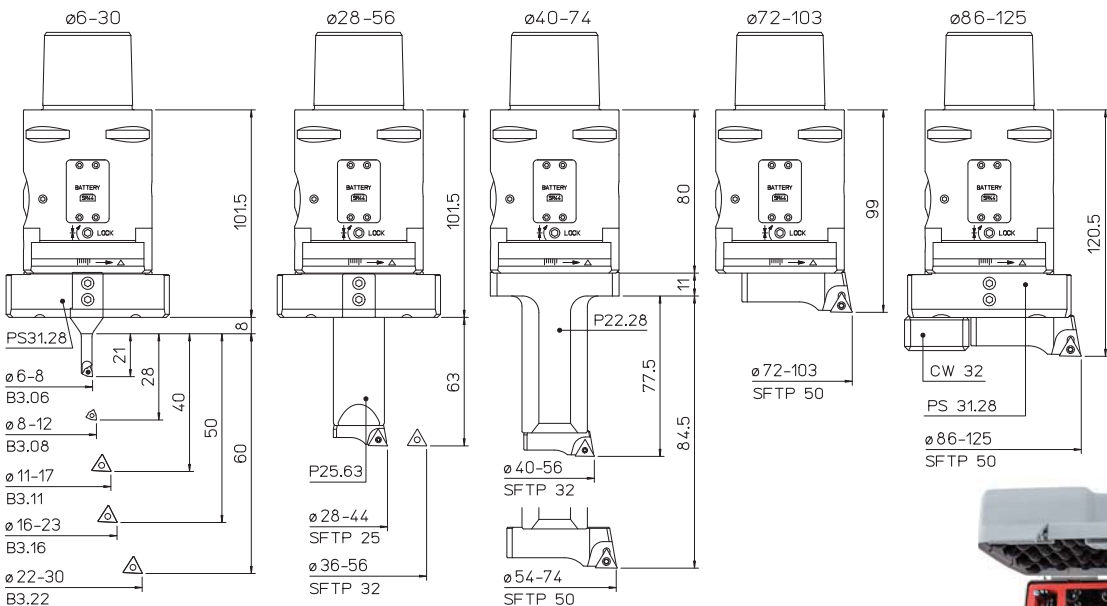




2 µm



REF.	CODE	Kg.
TR-ELETTRA 63 PSC 63	455256326060	2.1



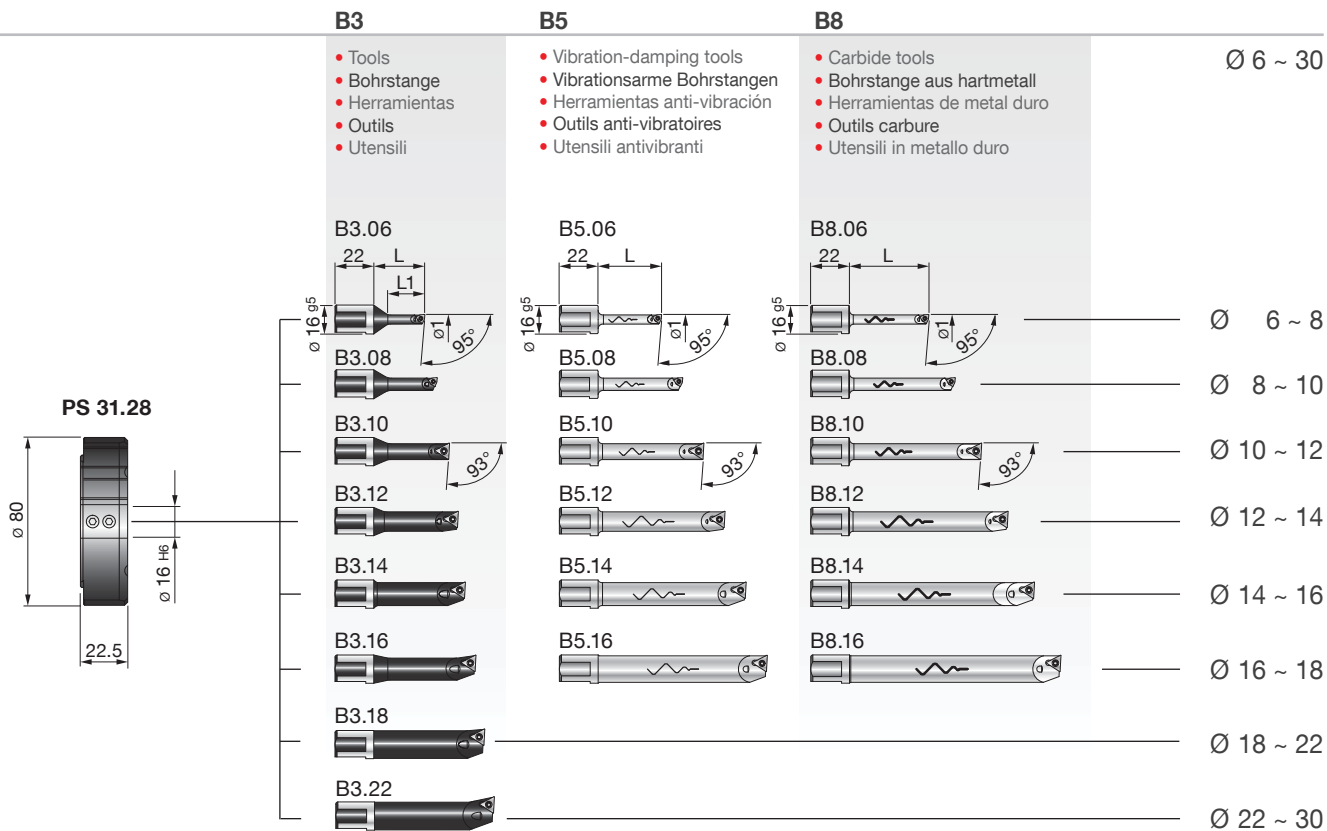
**KIT K01**  
Ø 6 ~ 125

- 1 TR-ELETTRA 63 PSC 63
- 1 P25.63 1 B3.06 1 B3.22 5 TPGX 090202L DC100
- 1 P22.28 1 B3.08 1 SFTP25 1 TPGX 110302L DC100
- 1 PS 31.28 1 B3.11 1 SFTP32 2 WCGT 020102L DC100
- 1 CW 32 1 B3.16 1 SFTP50



REF.	CODE	Ø
KIT K01 TR-ELETTRA 63 PSC 63	655256326060	6 ~ 125





REF.	CODE	Kg.
PS 31.28 TR-ELETTRA 63	433028220802	0.3

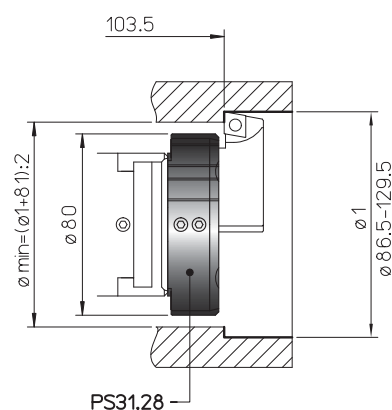
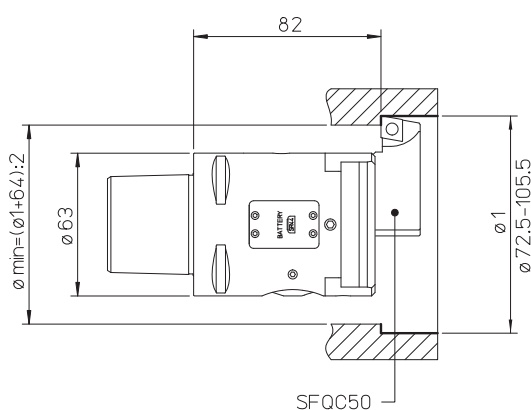
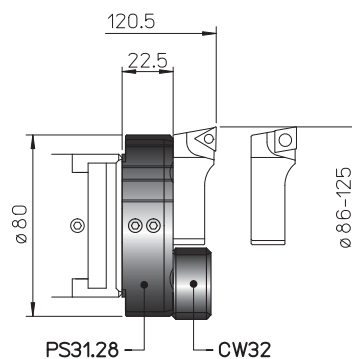
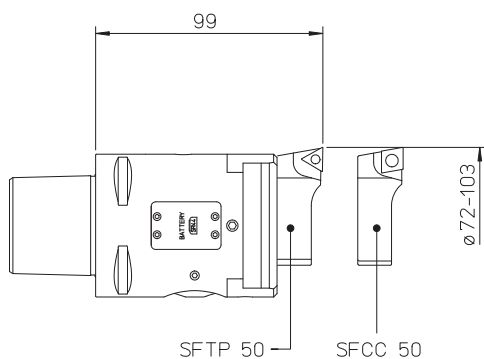
REF.	CODE	Ø1	L	L1	⚠	⚠	🔧	🔧	Kg.
B3.06	57 201 05 06 001	6 ~ 8	29	21	WCGT 0201..	-	TS 21	TORX T06	0.035
B3.08	57 201 05 08 001	8 ~ 10	36	28			TS 211		0.04
B3.10	57 201 05 10 001	10 ~ 12	43	35	-	TPGX 0902..	CS 250 T	TORX T08	0.05
B3.11	57 201 05 11 001	11 ~ 13	48	40					0.055
B3.12	57 201 05 12 001	12 ~ 14	48	42					0.06
B3.14	57 201 05 14 001	14 ~ 16	52	50					0.07
B3.16	57 201 05 16 001	16 ~ 18	58	-	-	TPGX 0902..	CS 250 T	TORX T08	0.1
B3.18	57 201 05 18 001	18 ~ 22	63	-					0.2
B3.22	57 201 05 22 001	22 ~ 30	68	-					0.3
B5.06	57 201 05 06 105	6 ~ 8	36	-	WCGT 0201..	-	TS 21	TORX T06	0.075
B5.08	57 201 05 08 105	8 ~ 10	48						TS 211
B5.10	57 201 05 10 105	10 ~ 12	60	-	-	TPGX 0902..	CS 250 T	TORX T08	0.1
B5.12	57 201 05 12 105	12 ~ 14	72						0.2
B5.14	57 201 05 14 105	14 ~ 16	84						0.3
B5.16	57 201 05 16 105	16 ~ 18	96						
B8.06	57 201 05 06 108	6 ~ 8	45	-	WCGT 0201..	-	TS 21	TORX T06	0.065
B8.08	57 201 05 08 108	8 ~ 10	60				TS 211		0.08
B8.10	57 201 05 10 108	10 ~ 12	75	-	-	TPGX 0902..	CS 250 T	TORX T08	0.1
B8.12	57 201 05 12 108	12 ~ 14	90						0.2
B8.14	57 201 05 14 108	14 ~ 16	105						0.3
B8.16	57 201 05 16 108	16 ~ 18	120						



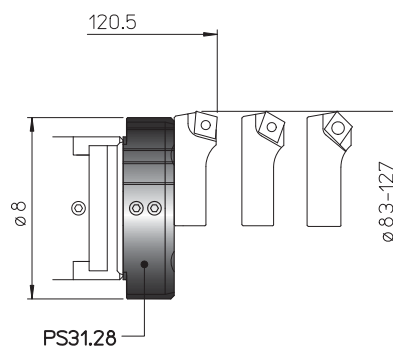
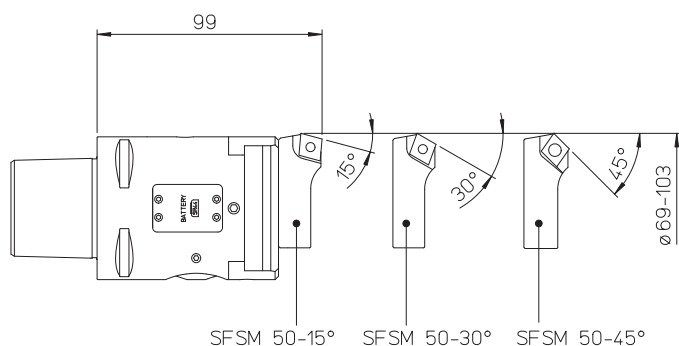
#### PSC 63 ISO 26623-1

- TOOLHOLDERS FOR TESTAROSSA
- WERKZEUGE FÜR TESTAROSSA
- PORTAHERRAMIENTAS PARA TESTAROSSA
- PORTE-OUTILS POUR TESTAROSSA
- PORTAUTENSILI PER TESTAROSSA

**PS 31**  
**CW 32**  
Ø 72~ 125



**PS 31**  
Ø 72.5 ~ 129.5



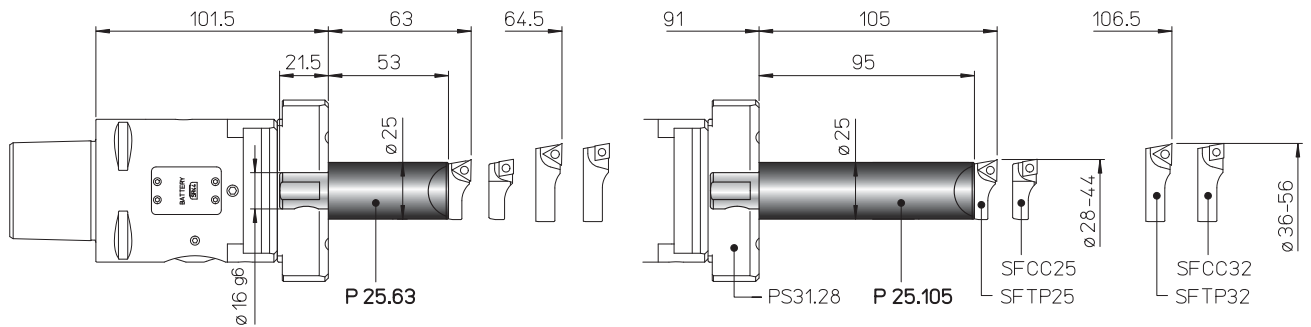
**PS 31**  
Ø 69 ~ 127

REF.	CODE	Kg.
PS 31.28 TR-ELETTRA 63	433028220802	0.3
CW 32	392011003201	0.07



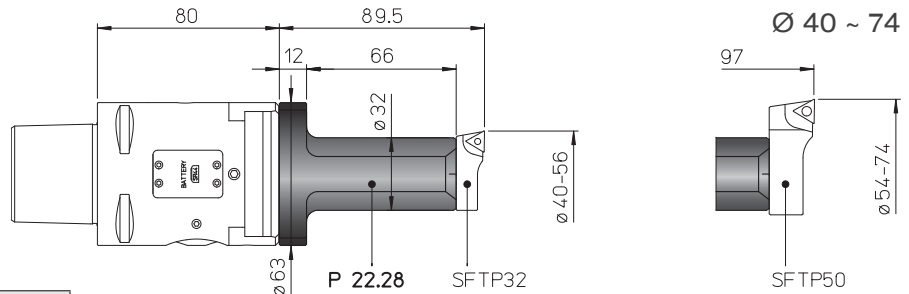
- TOOLHOLDERS FOR TESTAROSSA
- WERKZEUGE FÜR TESTAROSSA
- PORTAHERRAMIENTAS PARA TESTAROSSA
- PORTE-OUTILS POUR TESTAROSSA
- PORTAUTENSILI PER TESTAROSSA

P 25  
Ø 28 ~ 56



REF.	CODE	Kg.
P25.63 TR...	435116250631	0.5
P25.105 TR...	435116251051	0.8

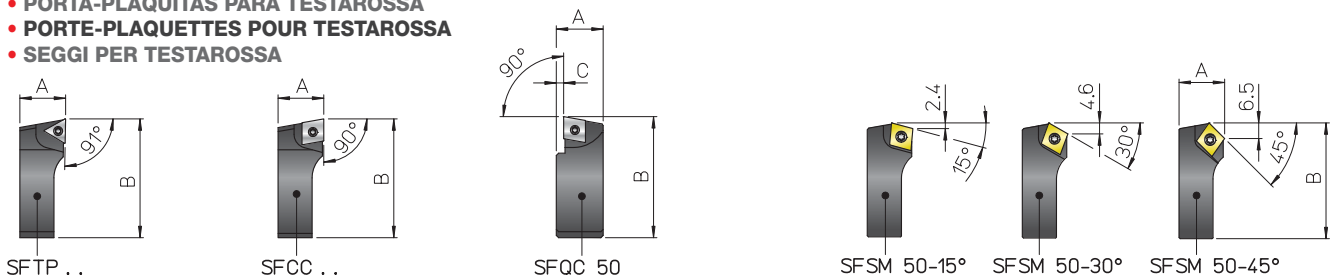
P 22  
Ø 40 ~ 74



REF.	CODE	Kg.
P 22.28	433028220631	0.45

- BIT-HOLDERS FOR TESTAROSSA
- PLATTENHALTER FÜR TESTAROSSA
- PORTA-PLAQUITAS PARA TESTAROSSA
- PORTE-PLAQUETTES POUR TESTAROSSA
- SEGGI PER TESTAROSSA

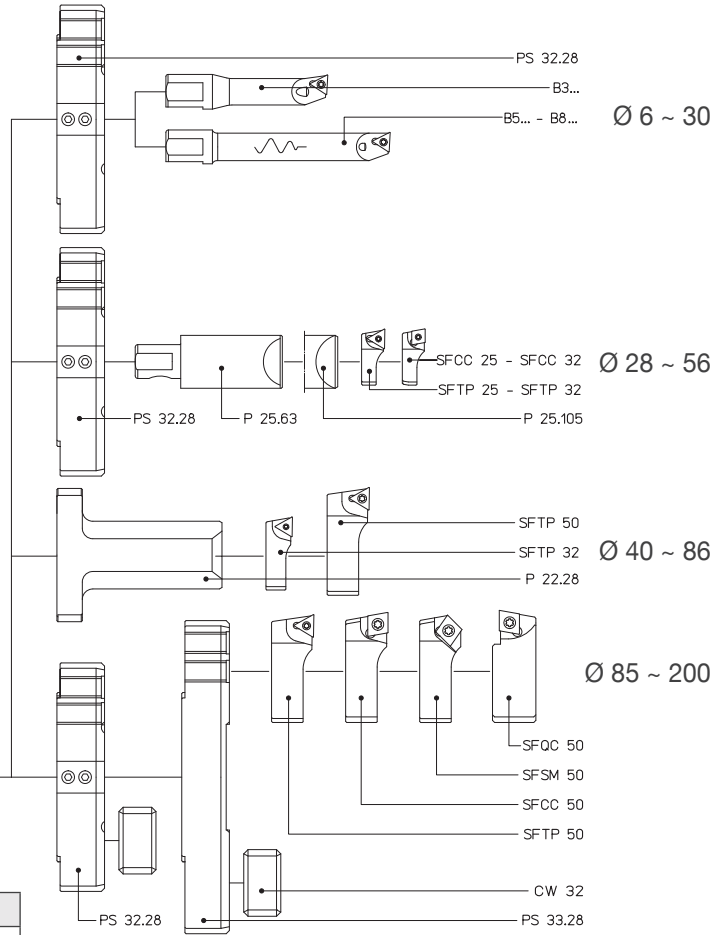
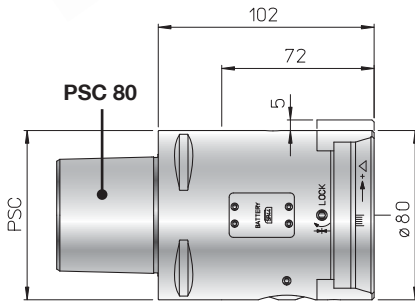
SF



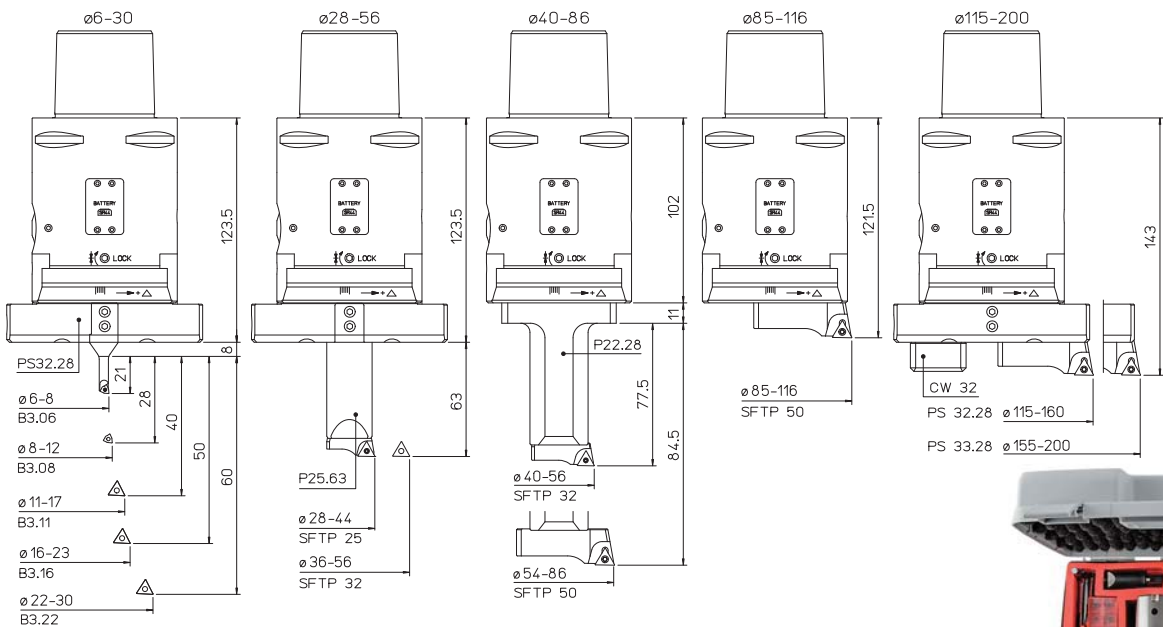
REF.	CODE	A	B	C					Kg.
SFTP 25	470500525001	10	26.5	-	TPGX 0902..	-	CS 250T	TORX T08	0.01
SFTP 32	470500532001	11.5	34.5	-	-	-	-	-	0.02
SFTP 50	470500550001	19	52	-	TPGX 1103..	-	CS 300890T	-	0.08
SFCC 25	470500525002	10	26.5	-	-	CCGT 0602..	TS 25	TORX T08	0.01
SFCC 32	470500532002	11.5	34.5	-	-	-	-	-	0.02
SFCC 50	470500550002	19	52	-	-	CCGT 09T3..	TS 4	TORX T15	0.08
SFQC 50	470500550062	20.5	53	3	-	CCMT 09T3..	TS 4	TORXT15	0.1
SFSM 50-15°	470500550011	19	50.5	-	-	CCMT 09T3..	TS 4	TORXT15	0.07
SFSM 50-30°	470500550013								
SFSM 50-45°	470500550015								



**2  $\mu\text{m}$**



REF.	CODE	Kg.
TR-ELETTRA 80 PSC 80	455258026080	4.4



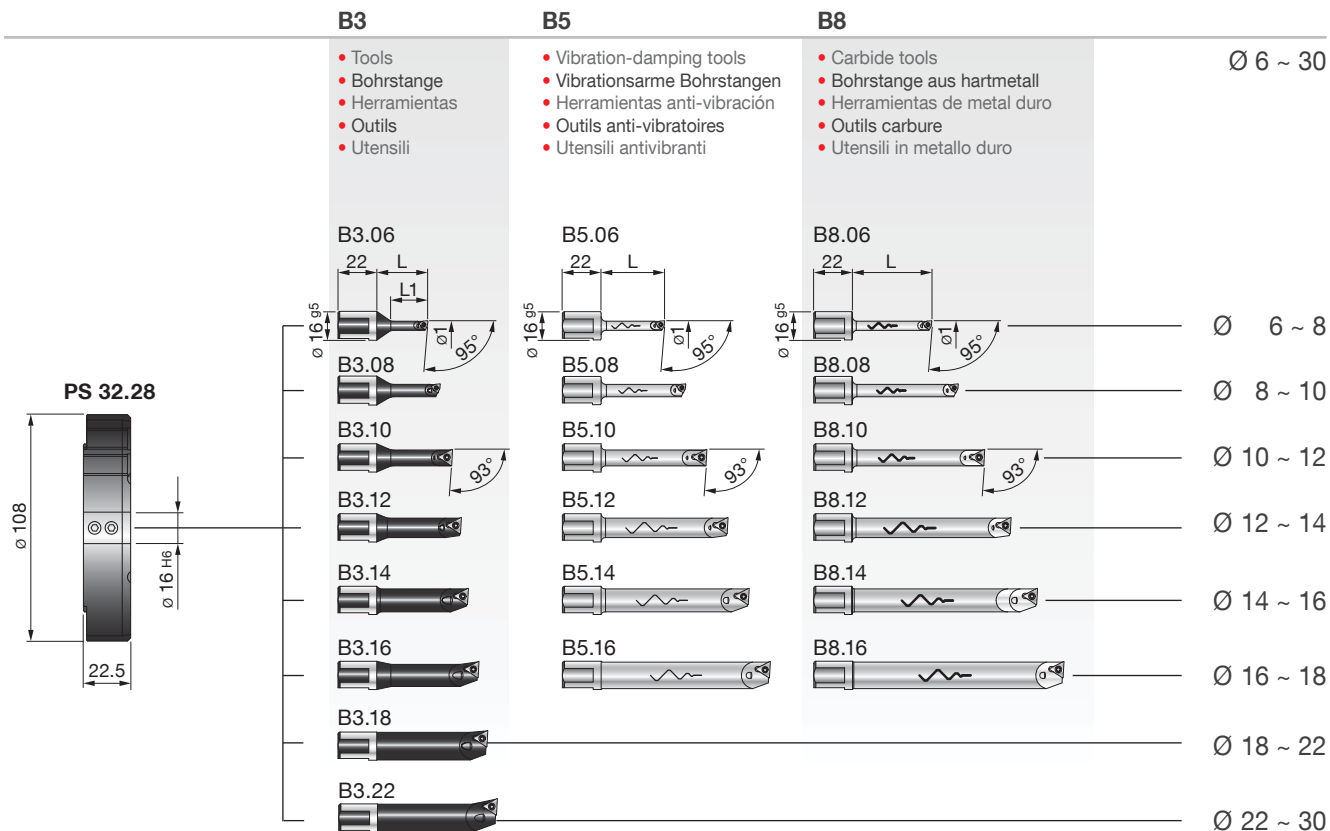
**KIT K01**  
 $\varnothing 6 \sim 200$

- 1 TR-ELETTRA 80 PSC 80
- 1 P25.63    1 CW 32    1 B3.16    1 SFTP50
- 1 P22.28    1 B3.06    1 B3.22    5 TPGX 090202L DC100
- 1 PS 32.28    1 B3.08    1 SFTP25    1 TPGX 110302L DC100
- 1 PS 33.28    1 B3.11    1 SFTP32    2 WCGT 020102L DC100



REF.	CODE	$\varnothing$
KIT K01 TR-ELETTRA 80 PSC 80	655258026080	6 ~ 200





REF.	CODE	Kg.
PS 32.28 TR-ELETTRA 80	433028221082	0.5

REF.	CODE	Ø1	L	L1	⚠	⚠	🔩	🔩	Kg.
B3.06	572010506001	6 ~ 8	29	21	WCGT 0201..	-	TS 21	TORX T06	0.035
B3.08	572010508001	8 ~ 10	36	28			TS 211		0.04
B3.10	572010510001	10 ~ 12	43	35	-	TPGX 0902..	CS 250 T	TORX T08	0.05
B3.11	572010511001	11 ~ 13	48	40					0.055
B3.12	572010512001	12 ~ 14	48	42					0.06
B3.14	572010514001	14 ~ 16	52	50	-	TPGX 0902..	CS 250 T	TORX T08	0.07
B3.16	572010516001	16 ~ 18	58	50					0.07
B3.18	572010518001	18 ~ 22	63	-	-	TPGX 0902..	CS 250 T	TORX T08	0.1
B3.22	572010522001	22 ~ 30	68	-					0.1

B5.06	572010506105	6 ~ 8	36	-	WCGT 0201..	-	TS 21	TORX T06	0.075
B5.08	572010508105	8 ~ 10	48				TS 211		0.09
B5.10	572010510105	10 ~ 12	60	-	-	TPGX 0902..	CS 250 T	TORX T08	0.1
B5.12	572010512105	12 ~ 14	72						0.2
B5.14	572010514105	14 ~ 16	84						0.2
B5.16	572010516105	16 ~ 18	96						0.3

B8.06	572010506108	6 ~ 8	45	-	WCGT 0201..	-	TS 21	TORX T06	0.065
B8.08	572010508108	8 ~ 10	60				TS 211		0.08
B8.10	572010510108	10 ~ 12	75	-	-	TPGX 0902..	CS 250 T	TORX T08	0.1
B8.12	572010512108	12 ~ 14	90						0.2
B8.14	572010514108	14 ~ 16	105						0.2
B8.16	572010516108	16 ~ 18	120						0.3

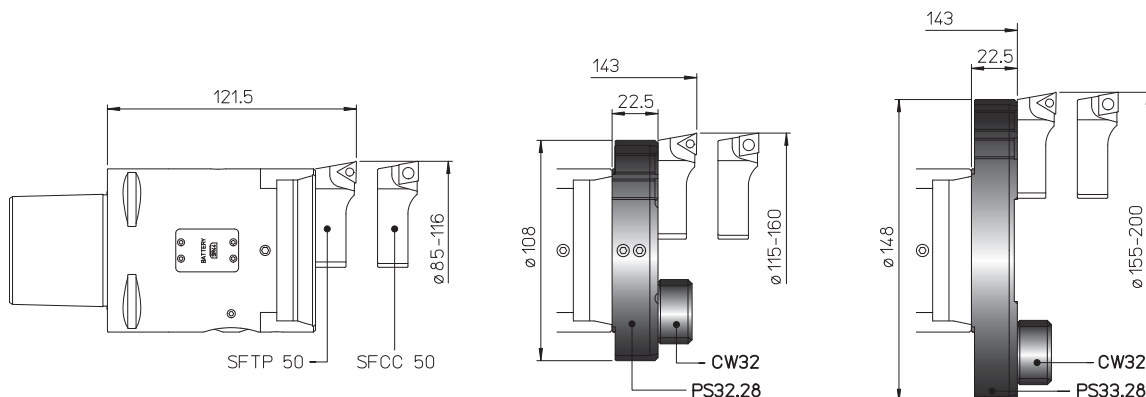




#### PSC 80 ISO 26623-1

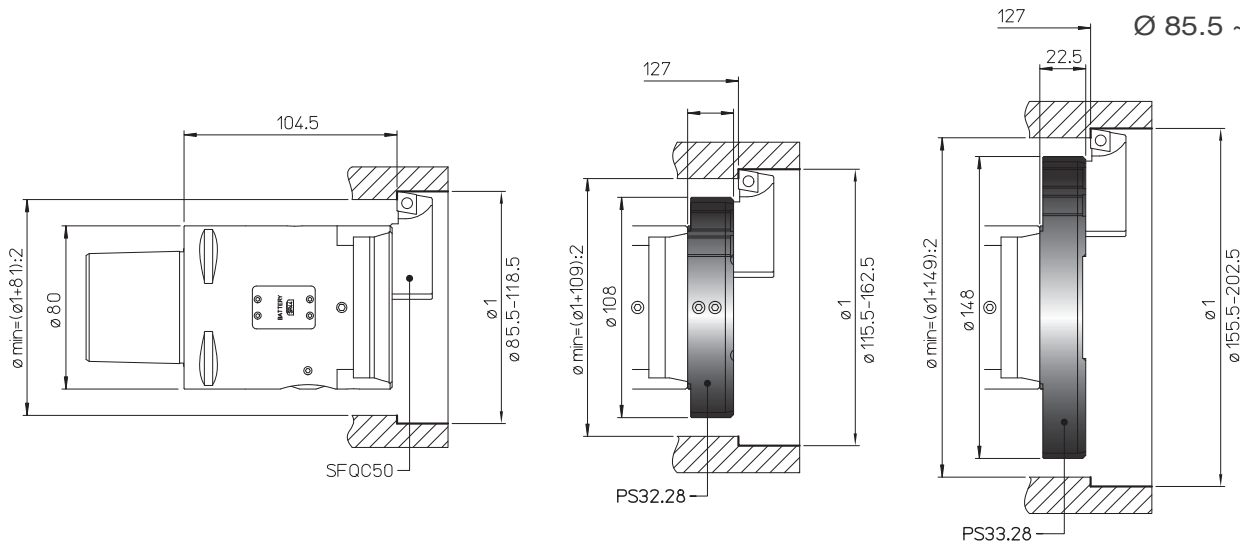
- TOOLHOLDERS FOR TESTAROSSA
- WERKZEUGE FÜR TESTAROSSA
- PORTAHERRAMIENTAS PARA TESTAROSSA
- PORTE-OUTILS POUR TESTAROSSA
- PORTAUTENSILI PER TESTAROSSA

**PS**  
**CW 32**  
Ø 85 ~ 200



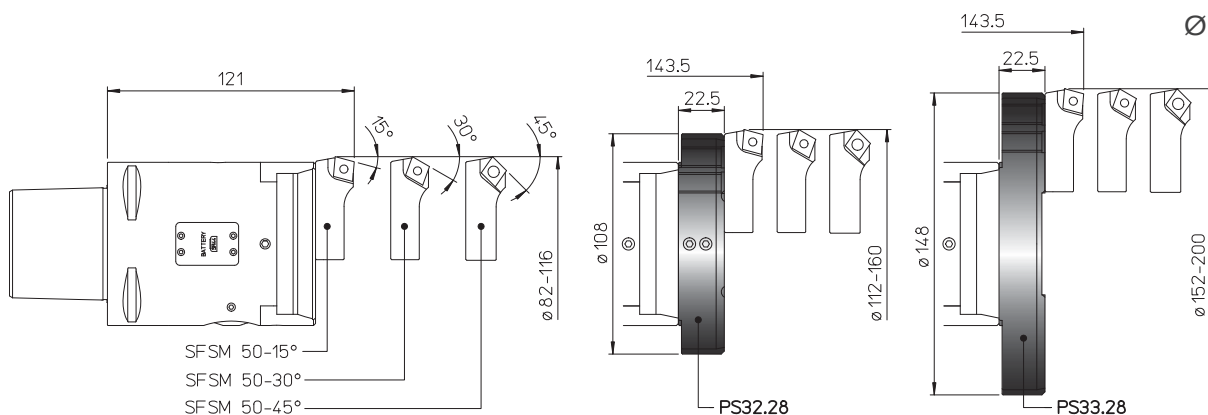
**PS**

Ø 85.5 ~ 202.5



**PS**

Ø 82 ~ 200

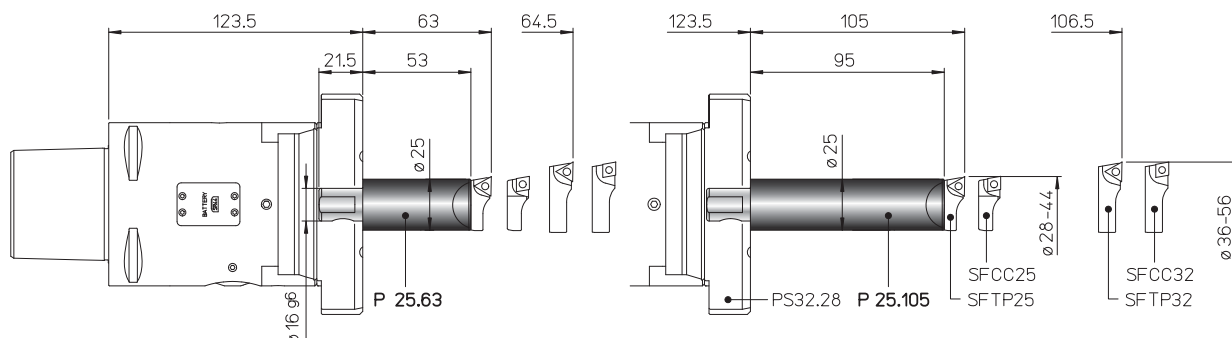


REF.	CODE	Kg.
PS 32.28 TR-ELETTRA 80	433028221082	0.5
PS 33.28 TR-ELETTRA 80	433028221482	0.6
CW 32	392011003201	0.07



- TOOLHOLDERS FOR TESTAROSSA
- WERKZEUGE FÜR TESTAROSSA
- PORTAHERRAMIENTAS PARA TESTAROSSA
- PORTE-OUTILS POUR TESTAROSSA
- PORTAUTENSILI PER TESTAROSSA

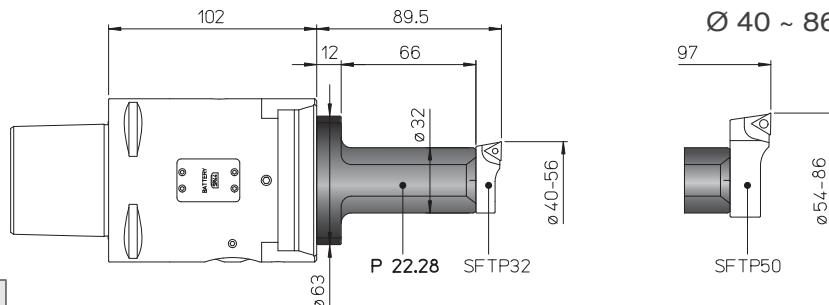
P 25  
Ø 28 ~ 56



REF.	CODE	Kg.
P25.63 TR...	435116250631	0.5
P25.105 TR..	435116251051	0.8

P 22

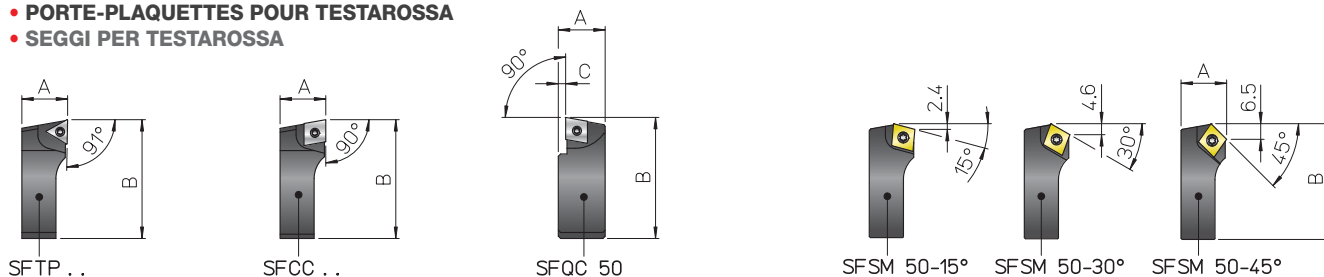
Ø 40 ~ 86



REF.	CODE	Kg.
P 22.28	433028220631	0.45

- BIT-HOLDERS FOR TESTAROSSA
- PLATTENHALTER FÜR TESTAROSSA
- PORTA-PLAQUITAS PARA TESTAROSSA
- PORTE-PLAQUETTES POUR TESTAROSSA
- SEGGI PER TESTAROSSA

SF



REF.	CODE	A	B	C					Kg.
SFTP 25	470500525001	10	26.5	-	TPGX 0902..	-	CS 250T	TORX T08	0.01
SFTP 32	470500532001	11.5	34.5	-					0.02
SFTP 50	470500550001	19	52	-	TPGX 1103..	-	CS 300890T		0.08
SFCC 25	470500525002	10	26.5	-		CCGT 0602..	TS 25	TORX T08	0.01
SFCC 32	470500532002	11.5	34.5	-					0.02
SFCC 50	470500550002	19	52	-		CCGT 09T3..	TS 4	TORX T15	0.08
SFQC 50	470500550062	20.5	53	3		CCMT 09T3..	TS 4	TORXT15	0.1
SFSM 50-15°	470500550011	19	50.5	-	-	CCMT 09T3..	TS 4	TORXT15	0.07
SFSM 50-30°	470500550013								
SFSM 50-45°	470500550015								

116

175

119





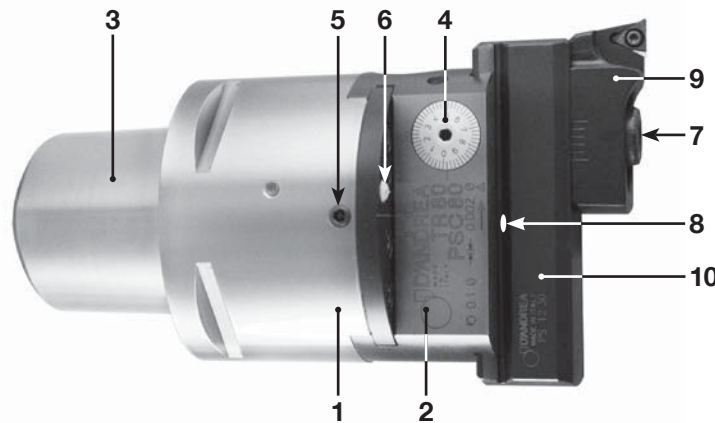
- 1 • Body  
• Körper  
• Cuerpo  
• Corps  
• Corpo
- 2 • Slide toolholder  
• Werkzeugschlitten  
• Guía portaherramientas  
• Coulisseau  
• Slitta portautensili
- 3 • PSC 40-50-63-80  
• PSC 40-50-63-80  
• PSC 40-50-63-80  
• PSC 40-50-63-80  
• PSC 40-50-63-80

- 4 • Micrometric vernier scale  
• Mikrometrischer Nonius  
• Nonio micrométrico  
• Vernier micrométrique  
• Nonio micrometrico

- 5 • Slide clamp screw  
• Schlittenklemmschraube  
• Tornillo bloqueo guía  
• Vis blocage coulisseau  
• Vite bloccaggio slitta

- 6 • Coolant outlet  
• Kühlmittelaustritt  
• Agujero salida refrigerante  
• Sortie du liquide d'arrosage  
• Uscita refrigerante

- 7 • Tools clamp screws  
• Werkzeugklemmschraube  
• Tornillo bloqueo herramientas  
• Vis blocage outil  
• Viti bloccaggio utensili



2 μm



- 8 • Oiler  
• Schmiernippel  
• Engrasador  
• Graisseur  
• Oliatore

- 9 • Bit holder  
• Plattenhalter  
• Portaplaquita  
• Porte-plaquettes  
• Seggio portainseriti

- 10 • Tool holder  
• Werkzeughalter  
• Portaherramienta  
• Porte-outil  
• Porta utensile

**GB FEATURES.** The TR-PSC heads in the D'Andrea Testarossa line have protective rustproof coating. High precision work to IT6 tolerance, with excellent surface finish, is achieved using TR-PSC boring heads. These are very sensitive and radial correction of 1 micron can be effected directly on the machine and easily read on the vernier scale.

**D MERKMALE.** Die TR-PSC Köpfe der Testarossa-Serie besitzen eine rostbeständige Oberfläche. Die TR-PSC-Köpfe ermöglichen ermöglichen Bearbeitungen mit hoher Präzision und Toleranzen mit Grad IT6 bei hochwertiger Oberflächengüte. Sie besitzen eine Feinverstellung mit einer Genauigkeit von radial 1 μm, wobei das Maß auf der Skala abgelesen und auch direkt an der Maschine eingestellt werden kann.

**E CARACTERÍSTICAS.** Los cabezales TR-PSC de la línea Testarossa D'Andrea cuentan con una protección superficial anticorrosión. Los cabezales TR-PSC permiten realizar operaciones de alta precisión con tolerancias de grado IT6 con un extraordinario acabado de la superficie. Tienen una sensibilidad de ajuste de 1 micra en radio, de fácil lectura en el nonio y corregibles directamente sobre la máquina.

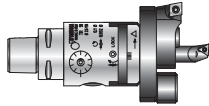
**F CARACTÉRISTIQUES.** Les têtes TR-PSC de la ligne Testarossa D'Andrea ont une protection superficielle anticorrosion. Les têtes TR-PSC permettent des usinages de haute précision avec des tolérances de degré IT6 pour un excellent finissage superficiel. Elles ont une sensibilité de réglage de 1 micron sur le rayon, facilement lisible sur le vernier et exécutable également dans la machine.

**I CARATTERISTICHE.** Le testine TR-PSC della linea Testarossa D'Andrea hanno una protezione superficiale anticorrosiva. Le testine TR-PSC consentono lavorazioni di alta precisione con tolleranze di grado IT6 con ottima finitura superficiale. Hanno una sensibilità di regolazione di 1 micron sul raggio, facilmente leggibile sul nonio ed eseguibile anche in macchina.



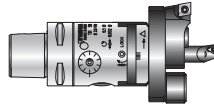
**TR50 - PSC40**

Ø 2.5 ~ 108



**TR50 - PSC50**

Ø 2.5 ~ 108



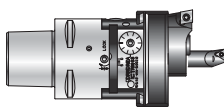
**TR50 - PSC63**

Ø 2.5 ~ 108



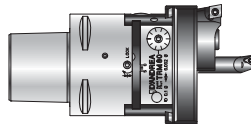
**TR63 - PSC63**

Ø 6 ~ 125



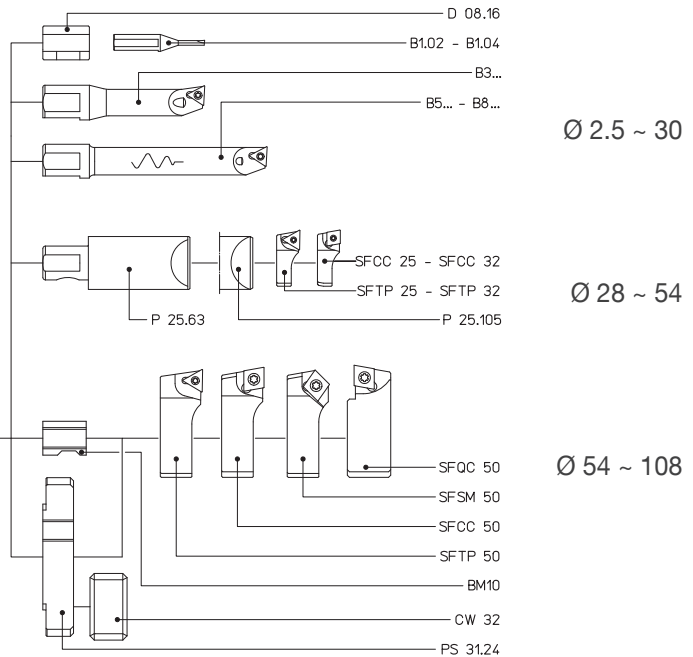
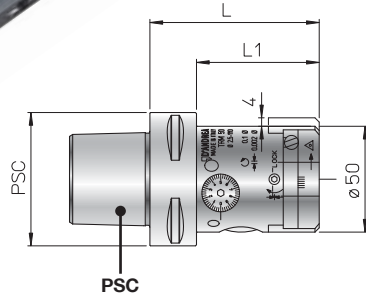
**TR80 - PSC80**

Ø 6 ~ 160



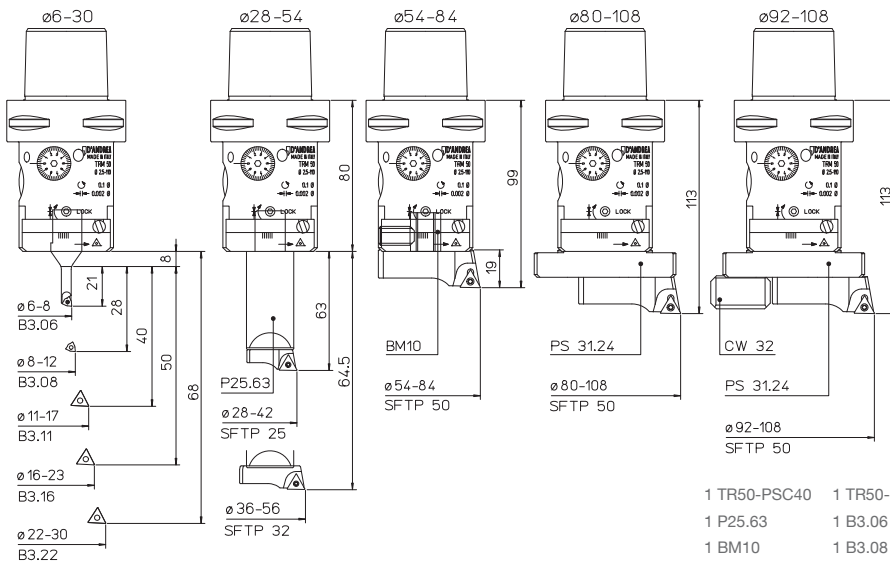


2 µm



PSC	REF.	CODE	L	L1	kg
40	TR 50 - PSC 40	455055026040	80	60	0.9
50	TR 50 - PSC 50	455055026050			1.1
63	TR 50 - PSC 63	455055026060		58	1.3

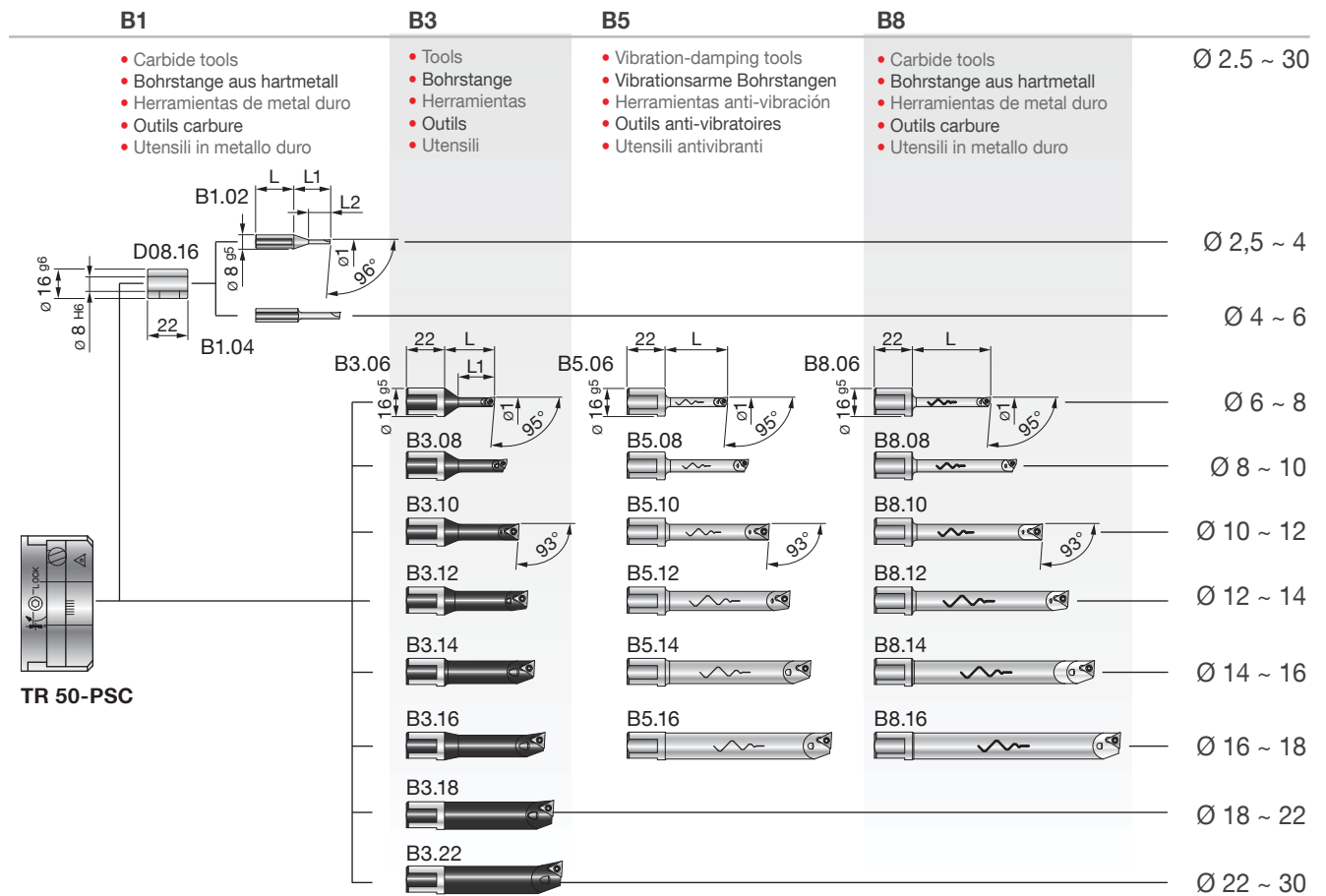
### KIT K01 Ø 6 ~ 108



1 TR50-PSC40	1 TR50-PSC50	1 TR50-PSC63	
1 P25.63	1 B3.06	1 B3.22	
1 BM10	1 B3.08	1 SFTP25	1 TPGX 110302L DC100
1 PS 31.24	1 B3.11	1 SFTP32	5 TPGX 090202L DC100
1 CW 32	1 B3.16	1 SFTP50	2 WCGT 020102L DC100

REF.	CODE	Ø
KIT K01 TR 50 - PSC40	655060410501	6 ~ 108
KIT K01 TR 50 - PSC50	655060510501	
KIT K01 TR 50 - PSC63	655060610501	





REF.	CODE	Kg.
D08.16	200560116082	0.02

REF.	CODE	Ø1	L	L1	L2	Kg.
B1.02	572010502001	2.5 ~ 4	22	21	12.5	0.02
B1.04	572010504001	4 ~ 6	24	24	-	

REF.	CODE	Ø1	L	L1	⊖	⊖	⊖	⊖	Kg.
B3.06	572010506001	6 ~ 8	29	21	WCGT 0201..	-	TS 21	TORX T06	0.035
B3.08	572010508001	8 ~ 10	36	28					0.04
B3.10	572010510001	10 ~ 12	43	35	-	TPGX 0902..	CS 250 T	TORX T08	0.05
B3.11	572010511001	11 ~ 13	48	40					0.055
B3.12	572010512001	12 ~ 14	48	42					0.06
B3.14	572010514001	14 ~ 16	52	50					0.07
B3.16	572010516001	16 ~ 18	58	50					0.07
B3.18	572010518001	18 ~ 22	63	-					0.1
B3.22	572010522001	22 ~ 30	68	-					0.1

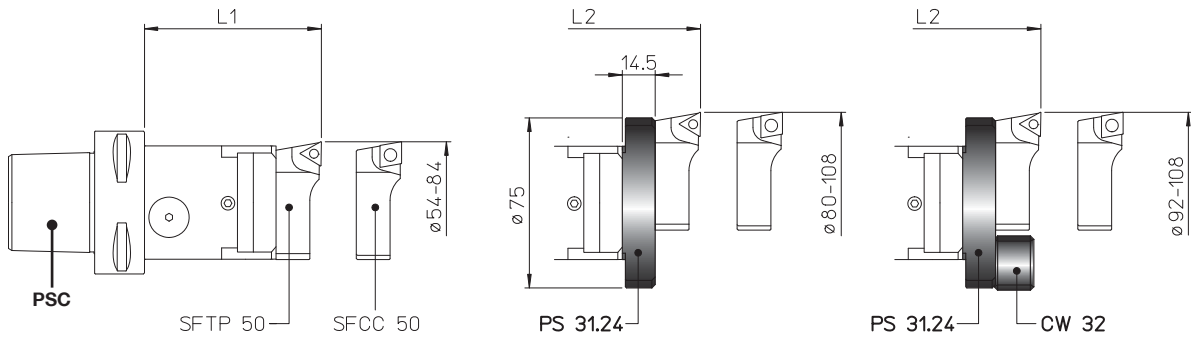
B5.06	572010506105	6 ~ 8	36	-	WCGT 0201..	-	TS 21	TORX T06	0.075
B5.08	572010508105	8 ~ 10	48	-					0.09
B5.10	572010510105	10 ~ 12	60	-	-	TPGX 0902..	CS 250 T	TORX T08	0.1
B5.12	572010512105	12 ~ 14	72	-					0.2
B5.14	572010514105	14 ~ 16	84	-					0.2
B5.16	572010516105	16 ~ 18	96	-					0.3

B8.06	572010506108	6 ~ 8	45	-	WCGT 0201..	-	TS 21	TORX T06	0.065
B8.08	572010508108	8 ~ 10	60	-					0.08
B8.10	572010510108	10 ~ 12	75	-	-	TPGX 0902..	CS 250 T	TORX T08	0.1
B8.12	572010512108	12 ~ 14	90	-					0.2
B8.14	572010514108	14 ~ 16	105	-					0.2
B8.16	572010516108	16 ~ 18	120	-					0.3



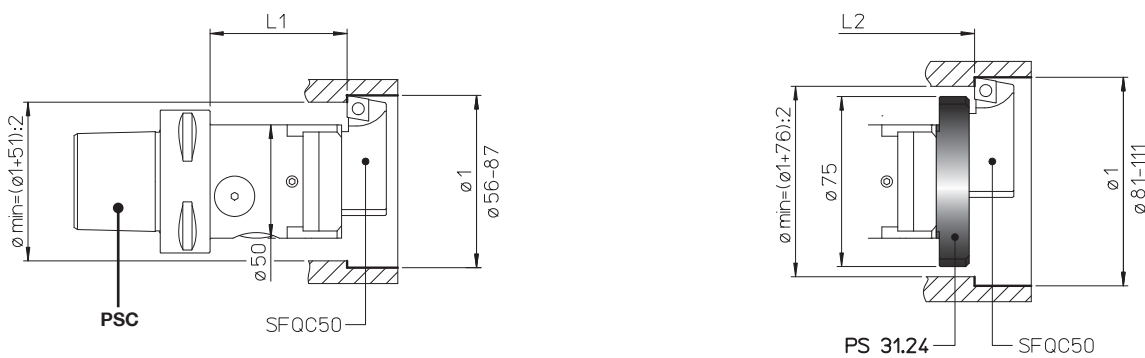
ISO 26623-1

- TOOLHOLDERS FOR TESTAROSSA
- WERKZEUGE FÜR TESTAROSSA
- PORTAHERRAMIENTAS PARA TESTAROSSA
- PORTE-OUTILS POUR TESTAROSSA
- PORTAUTENSILI PER TESTAROSSA



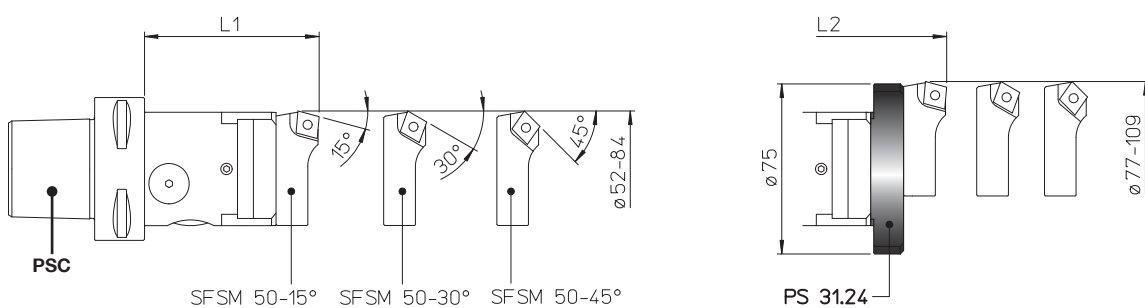
**PS 31**  
**CW 32**  
Ø 54~ 108

PSC	REF.	L1	L2
40	TR 50 - PSC 40	79	93
50	TR 50 - PSC 50		
63	TR 50 - PSC 63	77	91



**PS 31**  
Ø 56 ~ 111

PSC	REF.	L1	L2
40	TR 50 - PSC 40	62	76
50	TR 50 - PSC 50		
63	TR 50 - PSC 63	60	74



**PS 31**  
Ø 52 ~ 109

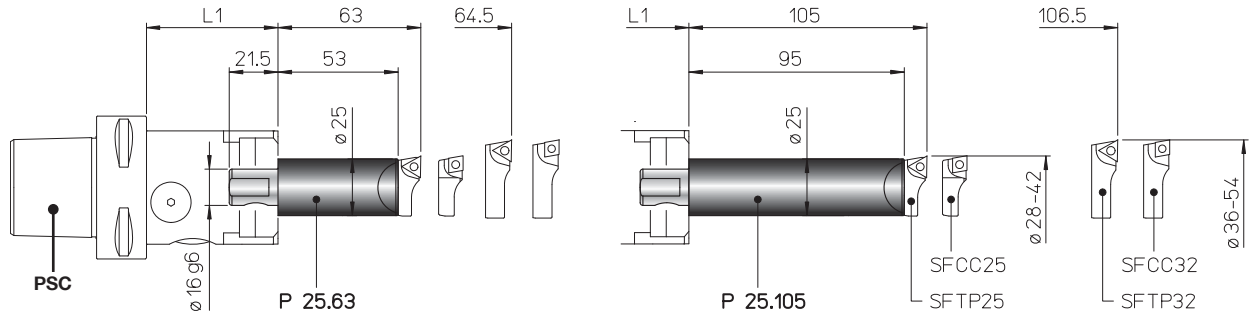
PSC	REF.	L1	L2
40	TR 50 - PSC 40	79	93
50	TR 50 - PSC 50		
63	TR 50 - PSC 63	77	91

REF.	CODE	Kg.
PS 31.24 TR..50	433024140751	0.19
CW 32	392011003201	0.07



- TOOLHOLDERS FOR TESTAROSSA
- WERKZEUGE FÜR TESTAROSSA
- PORTAHERRAMIENTAS PARA TESTAROSSA
- PORTE-OUTILS POUR TESTAROSSA
- PORTAUTENSILI PER TESTAROSSA

**P 25**  
Ø 28 ~ 54

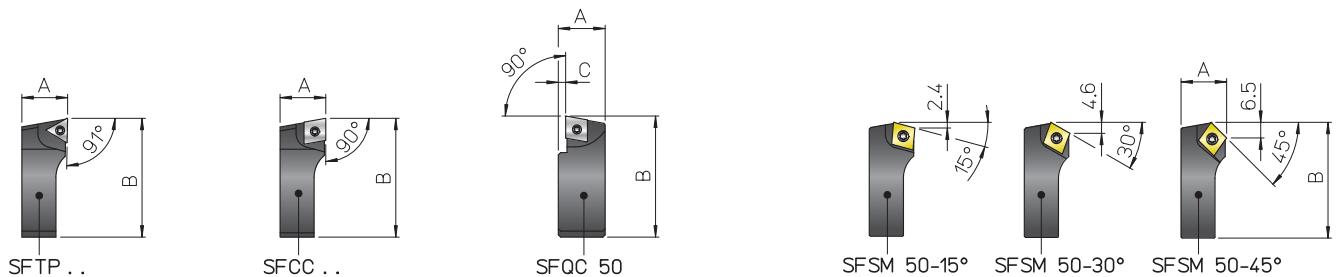


PSC	REF.	L1
40	TR 50 - PSC 40	60
50	TR 50 - PSC 50	
63	TR 50 - PSC 63	58

REF.	CODE	Kg.
P25.63 TR...	435116250631	0.5
P25.105 TR...	435116251051	0.8

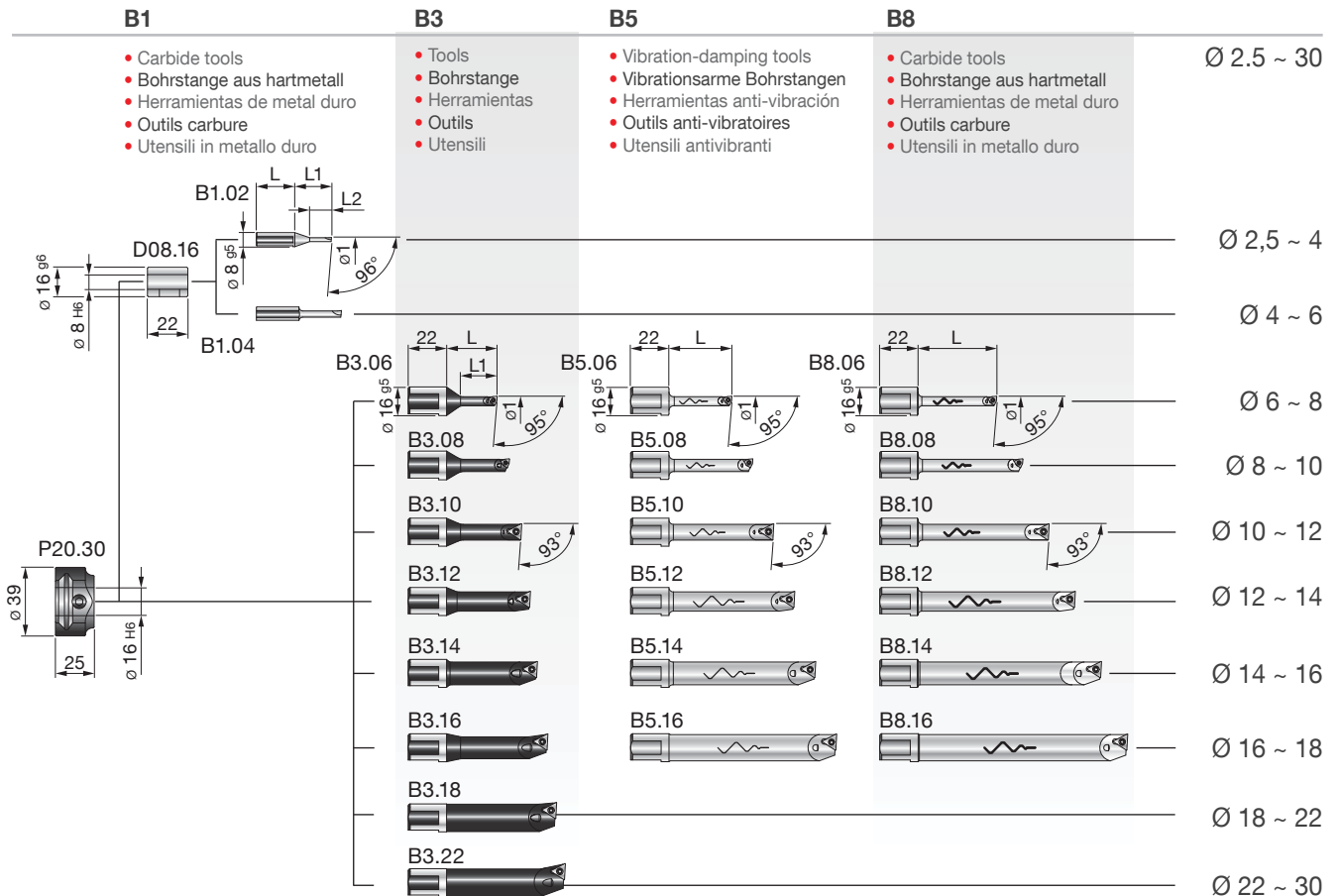
- BIT-HOLDERS FOR TESTAROSSA
- PLATTENHALTER FÜR TESTAROSSA
- PORTA-PLAQUITAS PARA TESTAROSSA
- PORTE-PLAQUETTES POUR TESTAROSSA
- SEGGI PER TESTAROSSA

**SF**



REF.	CODE	A	B	C	△	□	⊥	⌘	Kg.
SFTP 25	470500525001	10	26.5	-	TPGX 0902..	-	CS 250T	TORX T08	0.01
SFTP 32	470500532001	11.5	34.5	-	-	-	-		0.02
SFTP 50	470500550001	19	52	-	TPGX 1103..	-	CS 300890T		0.08
SFCC 25	470500525002	10	26.5	-	-	CCGT 0602..	TS 25	TORX T08	0.01
SFCC 32	470500532002	11.5	34.5	-	-	-	-	-	0.02
SFCC 50	470500550002	19	52	-	-	CCGT 09T3..	TS 4	TORX T15	0.08
SFQC 50	470500550062	20.5	53	3	-	CCMT 09T3..	TS 4	TORXT15	0.1
SFSM 50-15°	470500550011	19	50.5	-	-	CCMT 09T3..	TS 4	TORXT15	0.07
SFSM 50-30°	470500550013								
SFSM 50-45°	470500550015								





REF.	CODE	Kg.
P20.30	431030160300	0.2

REF.	CODE	Kg.
D08.16	200560116082	0.02

REF.	CODE	Ø1	L	L1	L2	Kg.
B1.02	572010502001	2.5 ~ 4	22	21	12.5	0.02
B1.04	572010504001	4 ~ 6	24	24	-	

REF.	CODE	Ø1	L	L1	⚠	⚠	🔧	🔧	Kg.
B3.06	572010506001	6 ~ 8	29	21	WCGT 0201..	-	TS 21	TORX T06	0.035
B3.08	572010508001	8 ~ 10	36	28			TS 211		0.04
B3.10	572010510001	10 ~ 12	43	35	-	TPGX 0902..	CS 250 T	TORX T08	0.05
B3.11	572010511001	11 ~ 13	48	40					0.055
B3.12	572010512001	12 ~ 14	48	42					0.06
B3.14	572010514001	14 ~ 16	52	50					0.07
B3.16	572010516001	16 ~ 18	58	-	-	-	-	-	0.1
B3.18	572010518001	18 ~ 22	63	-					
B3.22	572010522001	22 ~ 30	68	-					

B5.06	572010506105	6 ~ 8	36	-	WCGT 0201..	-	TS 21	TORX T06	0.075
B5.08	572010508105	8 ~ 10	48				TS 211		0.09
B5.10	572010510105	10 ~ 12	60	-	TPGX 0902..	CS 250 T	TORX T08	0.1	
B5.12	572010512105	12 ~ 14	72					0.2	
B5.14	572010514105	14 ~ 16	84					0.3	
B5.16	572010516105	16 ~ 18	96					0.3	

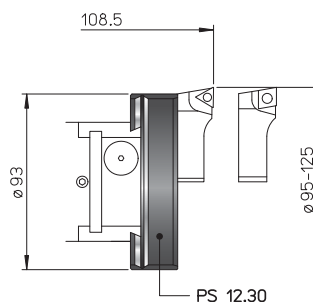
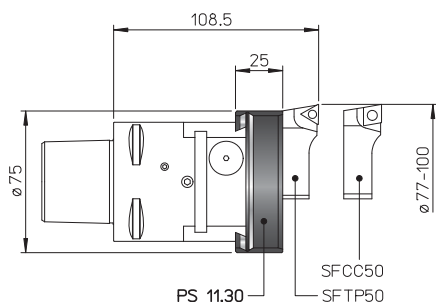
B8.06	572010506108	6 ~ 8	45	-	WCGT 0201..	-	TS 21	TORX T06	0.065
B8.08	572010508108	8 ~ 10	60				TS 211		0.08
B8.10	572010510108	10 ~ 12	75	-	TPGX 0902..	CS 250 T	TORX T08	0.1	
B8.12	572010512108	12 ~ 14	90					0.2	
B8.14	572010514108	14 ~ 16	105					0.3	
B8.16	572010516108	16 ~ 18	120					0.3	

ISO 26623-1

- TOOLHOLDERS FOR TESTAROSSA
- WERKZEUGE FÜR TESTAROSSA
- PORTAHERRAMIENTAS PARA TESTAROSSA
- PORTE-OUTILS POUR TESTAROSSA
- PORTAUTENSILI PER TESTAROSSA

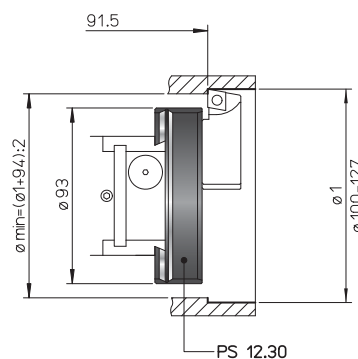
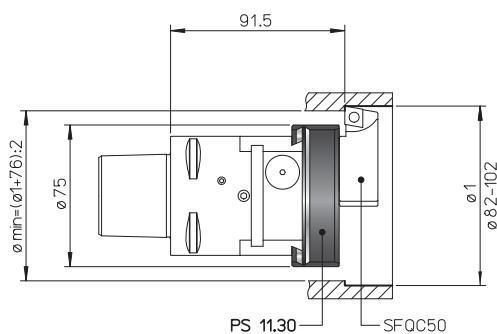
**PS**

Ø 77 ~ 125



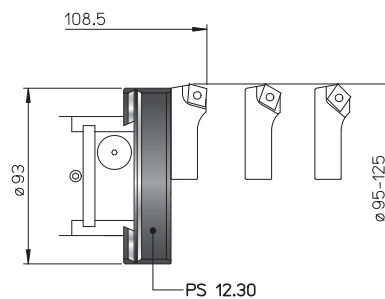
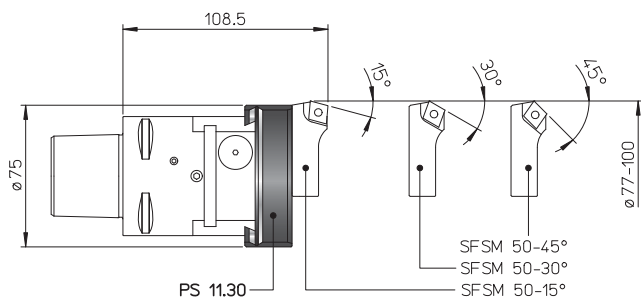
**PS**

Ø 82 ~ 127



**PS**

Ø 77 ~ 125



REF.	CODE	Kg.
PS 11.30	433030260750	0.4
PS 12.30	433030260950	0.5

119



175

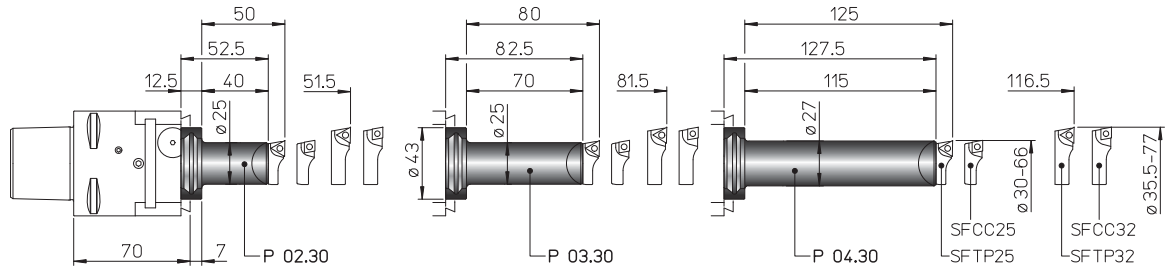


116



- TOOLHOLDERS FOR TESTAROSSA
- WERKZEUGE FÜR TESTAROSSA
- PORTAHERRAMIENTAS PARA TESTAROSSA
- PORTE-OUTILS POUR TESTAROSSA
- PORTAUTENSILI PER TESTAROSSA

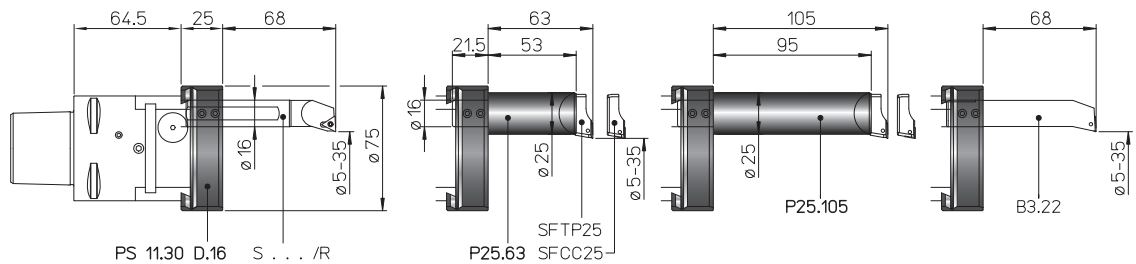
P  
Ø 30 ~ 77



REF.	CODE	Kg.
P02.30	431030250400	0.3
P03.30	431030250700	0.4
P04.30	431030251150	0.7

- TESTAROSSA EXTERNAL TURNING
- TESTAROSSA AUSSENDREHEN
- TESTAROSSA TORNEADO EXTERIOR
- TESTAROSSA TOURNAGE EXTÉRIEUR
- TESTAROSSA TORNITURA ESTERNA

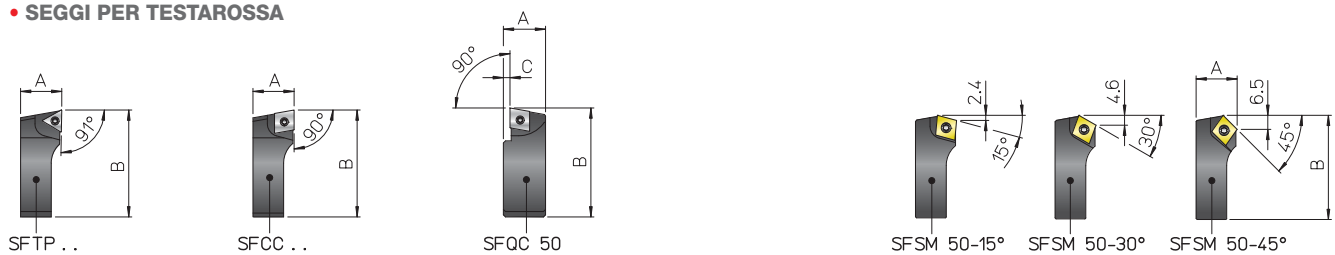
PS + P25  
Ø 5 ~ 35



REF.	CODE	Kg.
PS 11.30 D.16	433030260755	0.4
P25.63 TR...	435116250631	0.5
P25.105 TR...	435116251051	0.8

- BIT-HOLDERS FOR TESTAROSSA
- PLATTENHALTER FÜR TESTAROSSA
- PORTA-PLAQUITAS PARA TESTAROSSA
- PORTE-PLAQUETTES POUR TESTAROSSA
- SEGGI PER TESTAROSSA

SF

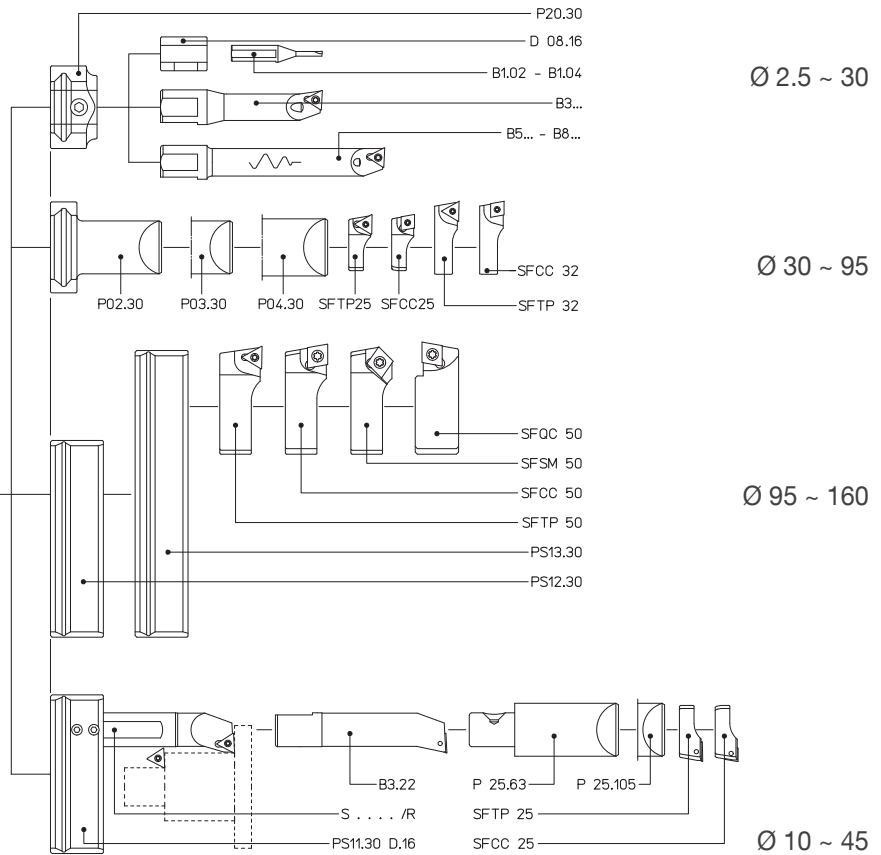
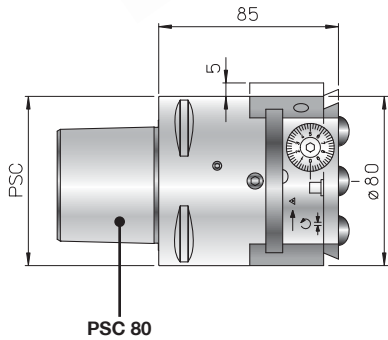


REF.	CODE	A	B	C	⚠	📏	🔧	🔩	Kg.
SFTP 25	470500525001	10	26.5	-	TPGX 0902..	-	CS 250T	TORX T08	0.01
SFTP 32	470500532001	11.5	34.5	-	-	-	-	-	0.02
SFTP 50	470500550001	19	52	-	TPGX 1103..	-	CS 300890T	-	0.08
SFCC 25	470500525002	10	26.5	-	-	CCGT 0602..	TS 25	TORX T08	0.01
SFCC 32	470500532002	11.5	34.5	-	-	-	-	-	0.02
SFCC 50	470500550002	19	52	-	-	CCGT 09T3..	TS 4	TORX T15	0.08
SFQC 50	470500550062	20.5	53	3	-	CCMT 09T3..	TS 4	TORXT15	0.1
SFSM 50-15°	470500550011	19	50.5	-	-	CCMT 09T3..	TS 4	TORXT15	0.07
SFSM 50-30°	470500550013								
SFSM 50-45°	470500550015								





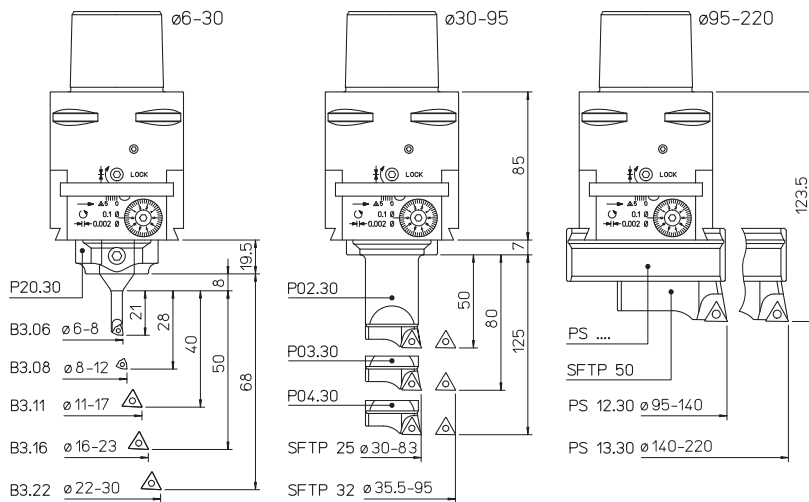
**2  $\mu$ m**



REF.	CODE	kg
TR 80 - PSC 80	455058026080	2.5

### KIT K01

$\varnothing$  6 ~ 220

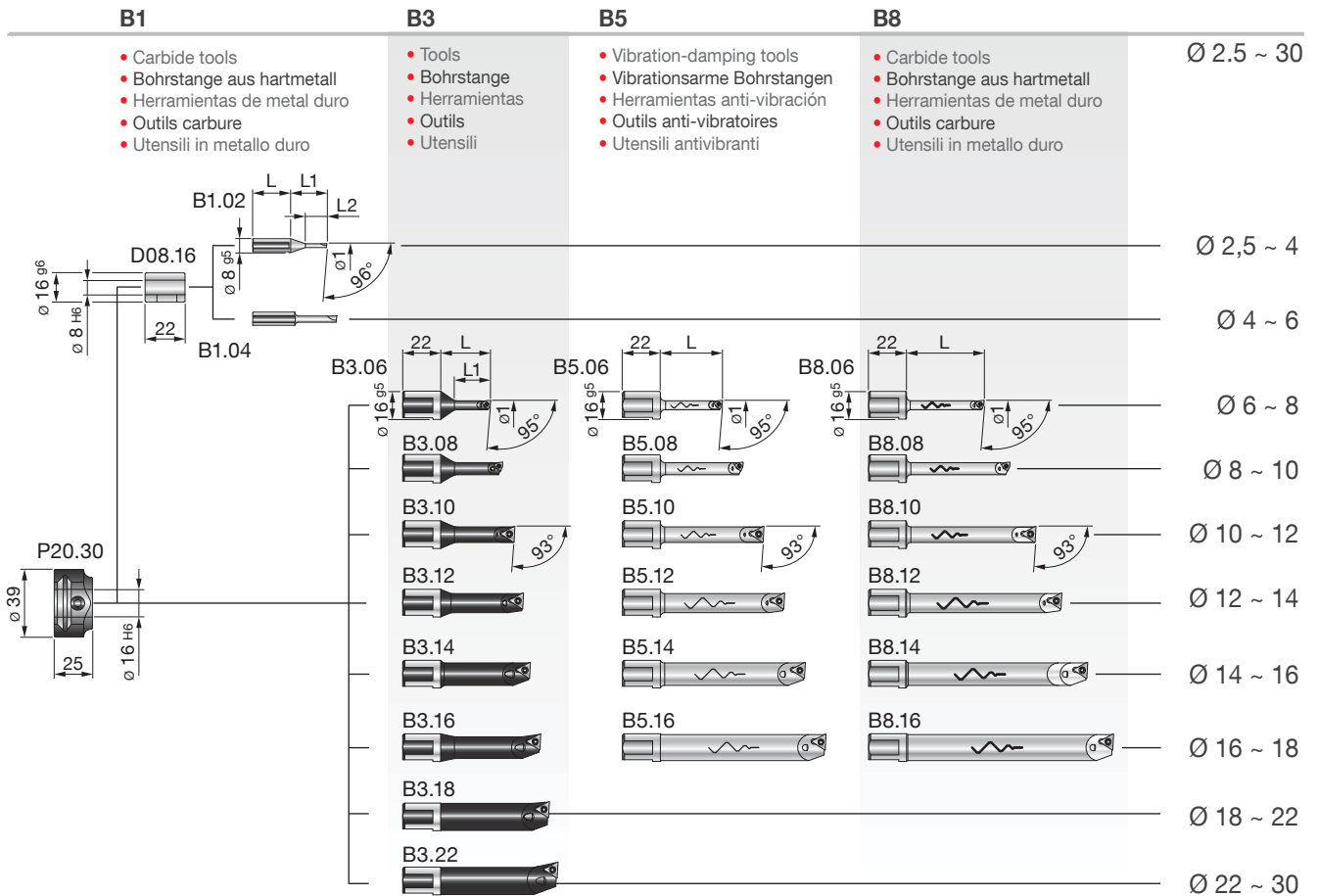


- 1 TR 80 - PSC 80
- 1 P20.30    1 P02.30    1 SFTP25    1 B3.06
- 1 PS12.30    1 P03.30    1 SFTP32    1 B3.08
- 1 PS13.30    1 P04.30    1 SFTP50    1 B3.12
- 5 TPGX 090202L DC100    1 B3.16
- 1 TPGX 110302L DC100    1 B3.22
- 2 WCGT 020102L DC100

REF.	CODE	$\varnothing$
KIT K01 TR 80 - PSC80	655060810801	6 ~ 220

252    119    174    116    241





REF.	CODE	Kg.
P20.30	431030160300	0.2

REF.	CODE	Kg.
D08.16	200560116082	0.02

REF.	CODE	Ø1	L	L1	L2	Kg.
B1.02	572010502001	2.5 ~ 4	22	21	12.5	0.02
B1.04	572010504001	4 ~ 6	24	24	-	

REF.	CODE	Ø1	L	L1	⚠	⚠	🔧	🔧	Kg.		
B3.06	572010506001	6 ~ 8	29	21	WCGT 0201..	-	TS 21	TORX T06	0.035		
B3.08	572010508001	8 ~ 10	36	28			TS 211		0.04		
B3.10	572010510001	10 ~ 12	43	35			-	TPGX 0902..	CS 250 T	TORX T08	0.05
B3.11	572010511001	11 ~ 13	48	40							0.055
B3.12	572010512001	12 ~ 14	48	42	0.06						
B3.14	572010514001	14 ~ 16	52	50	0.07						
B3.16	572010516001	16 ~ 18	58	-	0.1						
B3.18	572010518001	18 ~ 22	63	-							
B3.22	572010522001	22 ~ 30	68	-							

B5.06	572010506105	6 ~ 8	36	-	WCGT 0201..	-	TS 21	TORX T06	0.075
B5.08	572010508105	8 ~ 10	48				TS 211		0.09
B5.10	572010510105	10 ~ 12	60		-	TPGX 0902..	CS 250 T	TORX T08	0.1
B5.12	572010512105	12 ~ 14	72						0.2
B5.14	572010514105	14 ~ 16	84						0.3
B5.16	572010516105	16 ~ 18	96						

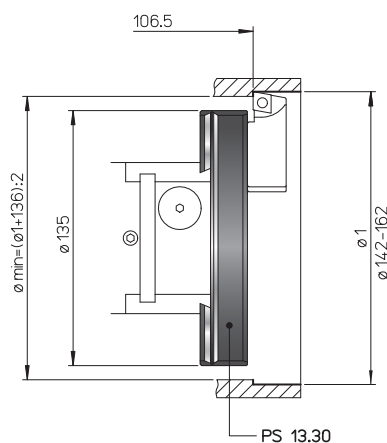
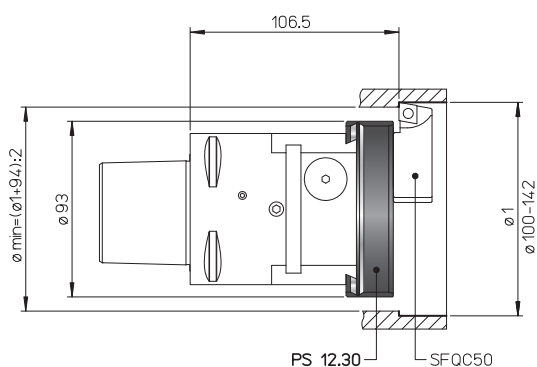
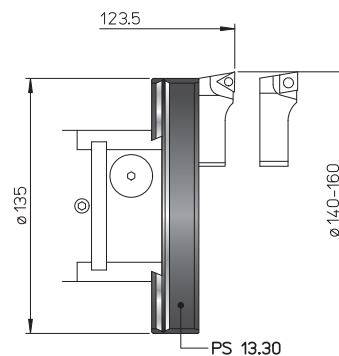
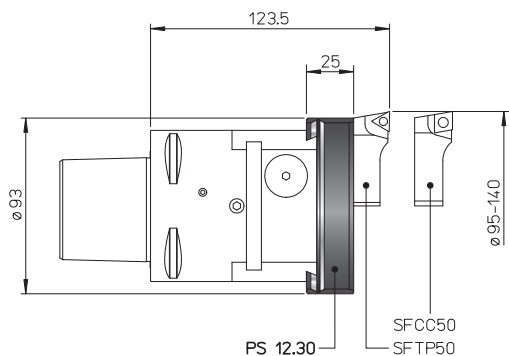
B8.06	572010506108	6 ~ 8	45	-	WCGT 0201..	-	TS 21	TORX T06	0.065
B8.08	572010508108	8 ~ 10	60				TS 211		0.08
B8.10	572010510108	10 ~ 12	75		-	TPGX 0902..	CS 250 T	TORX T08	0.1
B8.12	572010512108	12 ~ 14	90						0.2
B8.14	572010514108	14 ~ 16	105						0.3
B8.16	572010516108	16 ~ 18	120						

ISO 26623-1

- TOOLHOLDERS FOR TESTAROSSA
- WERKZEUGE FÜR TESTAROSSA
- PORTAHERRAMIENTAS PARA TESTAROSSA
- PORTE-OUTILS POUR TESTAROSSA
- PORTAUTENSILI PER TESTAROSSA

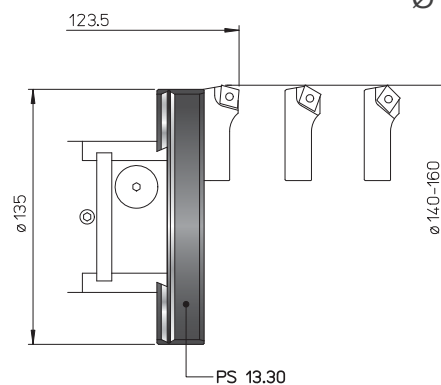
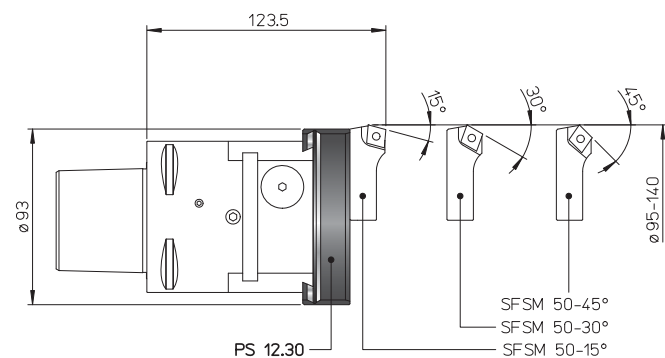
PS

Ø 95 ~ 160



PS

Ø 100 ~ 162



PS

Ø 95 ~ 160

REF.	CODE	Kg.
PS 12.30	433030260950	0.5
PS 13.30	433030261400	0.7

119



175

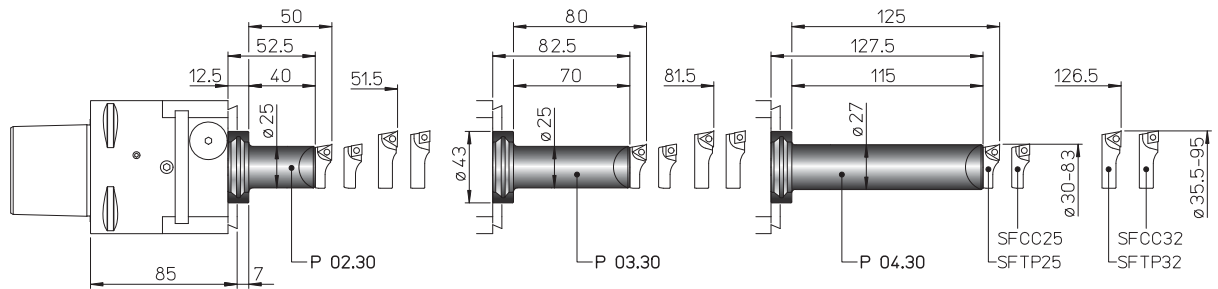


116



- TOOLHOLDERS FOR TESTAROSSA
- WERKZEUGE FÜR TESTAROSSA
- PORTAHERRAMIENTAS PARA TESTAROSSA
- PORTE-OUTILS POUR TESTAROSSA
- PORTAUTENSILI PER TESTAROSSA

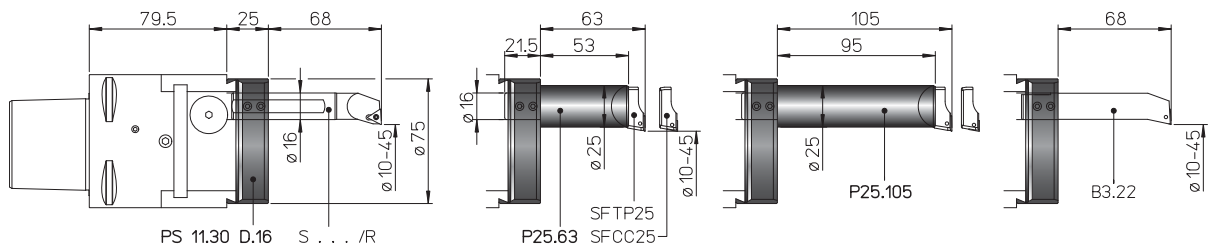
P  
Ø 30 ~ 95



REF.	CODE	Kg.
P02.30	431030250400	0.3
P03.30	431030250700	0.4
P04.30	431030251150	0.7

- TESTAROSSA EXTERNAL TURNING
- TESTAROSSA AUSSENDREHEN
- TESTAROSSA TORNEADO EXTERIOR
- TESTAROSSA TOURNAGE EXTÉRIEUR
- TESTAROSSA TORNITURA ESTERNA

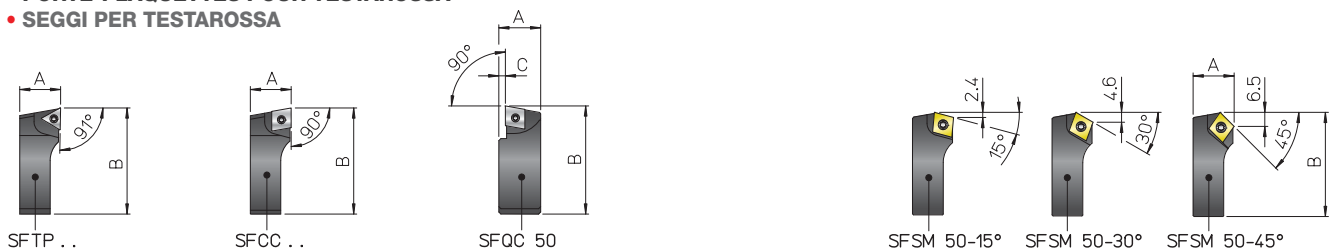
PS + P25  
Ø 10 ~ 45



REF.	CODE	Kg.
PS 11.30 D.16	433030260755	0.4
P25.63 TR...	435116250631	0.5
P25.105 TR...	435116251051	0.8

- BIT-HOLDERS FOR TESTAROSSA
- PLATTENHALTER FÜR TESTAROSSA
- PORTA-PLAQUITAS PARA TESTAROSSA
- PORTE-PLAQUETTES POUR TESTAROSSA
- SEGGI PER TESTAROSSA

SF



REF.	CODE	A	B	C	⚠	📏	🔧	🔩	Kg.
SFTP 25	470500525001	10	26.5	-	TPGX 0902..	-	CS 250T	TORX T08	0.01
SFTP 32	470500532001	11.5	34.5	-	-	-	-	-	0.02
SFTP 50	470500550001	19	52	-	TPGX 1103..	-	CS 300890T	-	0.08
SFCC 25	470500525002	10	26.5	-	-	CCGT 0602..	TS 25	TORX T08	0.01
SFCC 32	470500532002	11.5	34.5	-	-	-	-	-	0.02
SFCC 50	470500550002	19	52	-	-	CCGT 09T3..	TS 4	TORX T15	0.08
SFQC 50	470500550062	20.5	53	3	-	CCMT 09T3..	TS 4	TORXT15	0.1
SFSM 50-15°	470500550011	19	50.5	-	-	CCMT 09T3..	TS 4	TORXT15	0.07
SFSM 50-30°	470500550013								
SFSM 50-45°	470500550015								

- MILL HOLDER
- WERKZEUGAUFNAHME FÜR AUFSTECKFRÄSER
- PORTAFRESA
- PORTE-FRAISES
- PORTAFRESA



**PSC-PF**  
ISO 26623-1

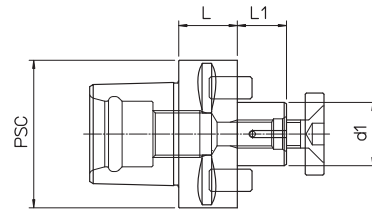
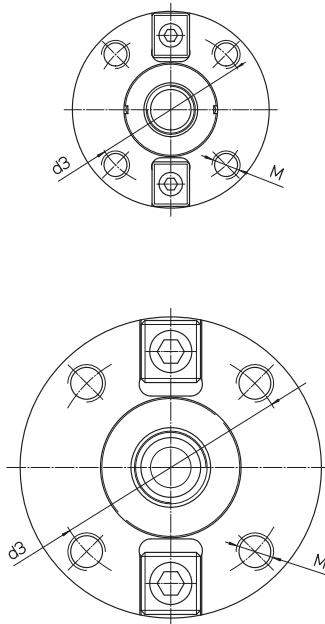


fig.1

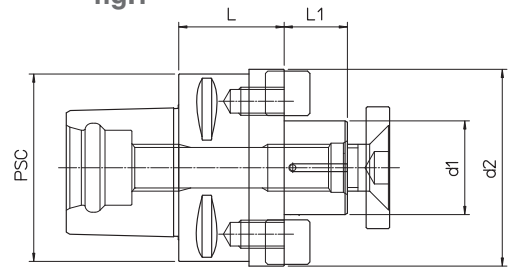


fig.2

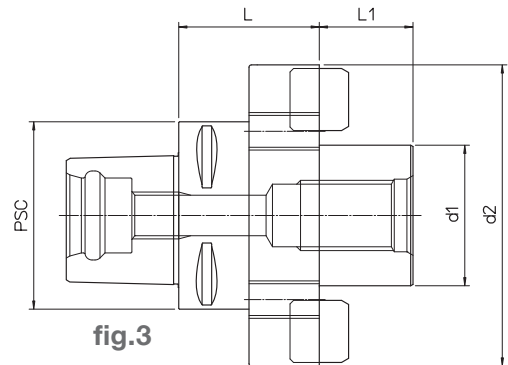


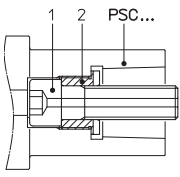
fig.3

PSC	REF.	CODE	d1	d2	d3	M	L	L1	kg	fig.
40	PSC 40 PF22.25	71PSC-040PF2202	22	-	-	-	25	19	0.3	1
50	PSC 50 PF22.25	71PSC-050PF2202							0.5	
	PSC 50 PF27.25	71PSC-050PF2702	0.6							
63	PSC 63 PF27.25	71PSC-063PF2702	0.8							
	PSC 63 PF32.25	71PSC-063PF3202	0.9							
80	PSC 80 PF32.30	71PSC-080PF3203	32					30	1.8	
	PSC 80 PF40.45	71PSC-080PF4004	40	84	66.7	M12	45	27	2.4	2
	PSC 80 PF60.60	71PSC-080PF6006	60	128.5	101.6	M16	60	40	5.2	3

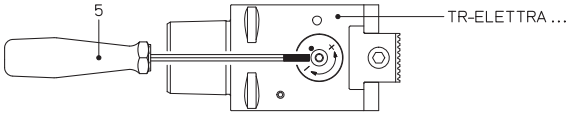


- SPARE PARTS
- ERSATZTEILE
- PIEZAS DE RECAMBIO
- PIÈCES ETACHÉES
- PARTI DI RICAMBIO

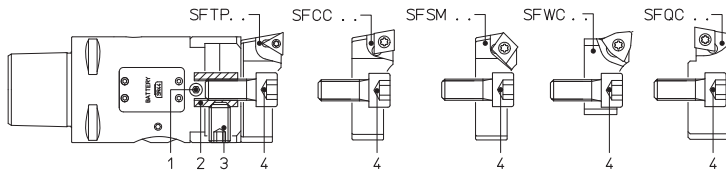
PSC



PSC	CODE 1	CODE 2
40	200100151445	201032215004
50	200100151655	201032515003
63	200101152065	201033015016
80		
100		



TR-ELETTRA



REF.	CODE 1	CODE 2	CODE 3	CODE 4	CODE 5
TR-ELETTRA 50	100238060010	201041015002	100231100016	100051100025	101500800300
TR-ELETTRA 63		-	-	100051100020	
TR-ELETTRA 80	200100150614	-	-	100051100025	

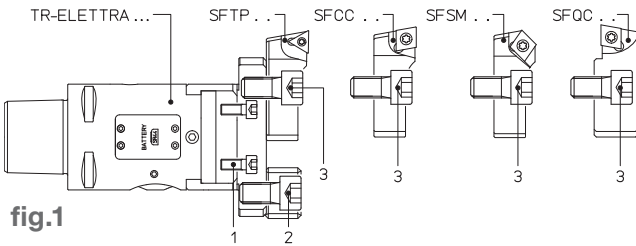


fig.1

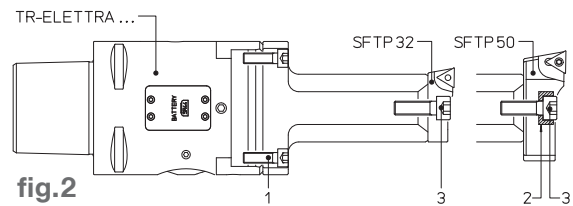
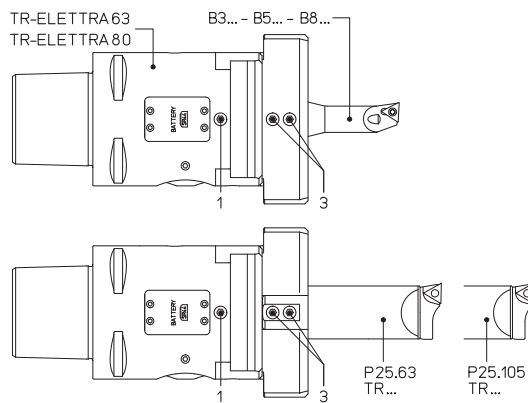
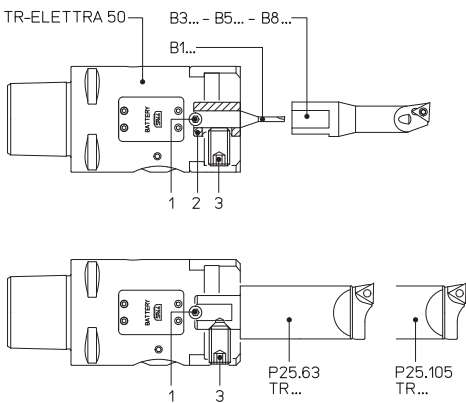


fig.2

TR-ELETTRA

REF.	CODE 1	CODE 2	CODE 3	fig
TR-ELETTRA 50	200100150501	100051100020	100051100025	1
TR-ELETTRA 63	100051050025			
TR-ELETTRA 80	100051050016	201040607001	100051006020	



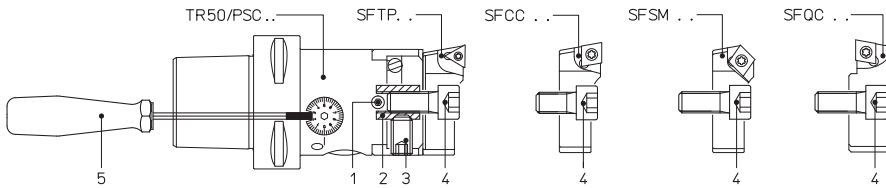
TR-ELETTRA

REF.	CODE 1	CODE 2	CODE 3
TR-ELETTRA 50	100238060010	200560116082	100231100016
TR-ELETTRA 63		-	100231060006
TR-ELETTRA 80	2001000150614	-	-



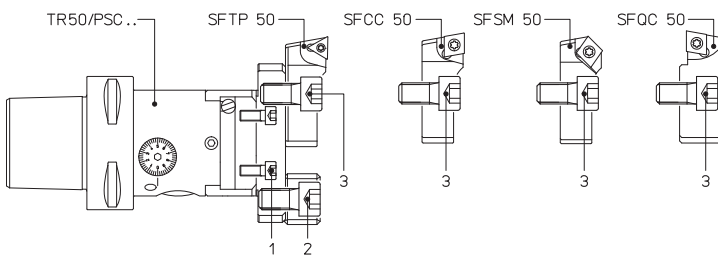
- SPARE PARTS
- ERSATZTEILE
- PIEZAS DE RECAMBIO
- PIÈCES ETACHÉES
- PARTI DI RICAMBIO

TR-PSC



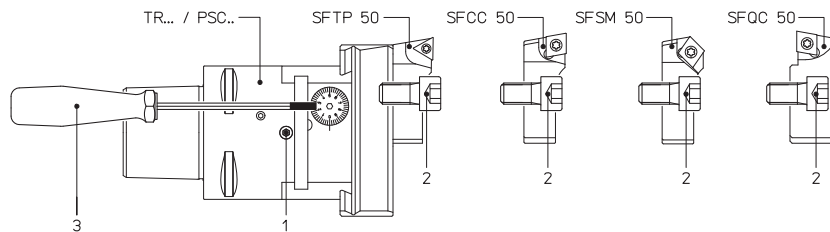
REF.	CODE 1	CODE 2	CODE 3	CODE 4	CODE 5
TR 50 PSC 40-50-63	100271050008	201041015002	100231100016	100051100025	101500800250

TR-PSC



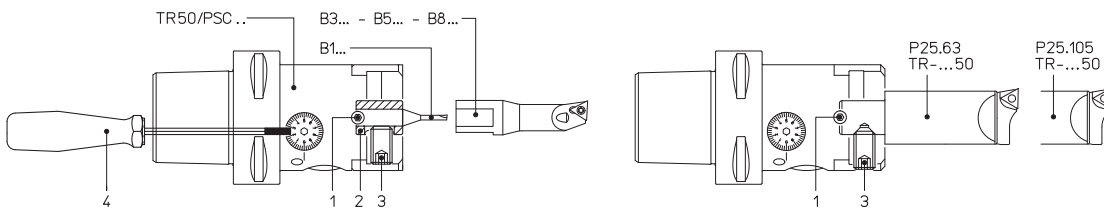
REF.	CODE 1	CODE 2	CODE 3
TR 50 - PSC 40-50-63	200100150501	100051100020	100051100025

TR-PSC



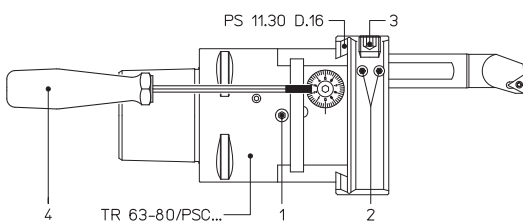
REF.	CODE 1	CODE 2	CODE 3
TR 63 - PSC 63	100251060010	100051100018	101500800300
TR 80 - PSC 80	100251060014		

TR-PSC



REF.	CODE 1	CODE 2	CODE 3	CODE 4
TR50 PSC40-50-63	100271050008	200560116082	100231100010	101500800250

TR-PSC

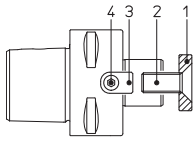


REF.	CODE 1	CODE 2	CODE 3	CODE 4
TR63 PSC63 TR80 PSC80	100251060014	100231050006	100231100010	101500800300



- SPARE PARTS
- ERSATZTEILE
- PIEZAS DE RECAMBIO
- PIÈCES ETACHÉES
- PARTI DI RICAMBIO

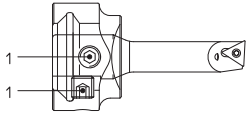
PSC - PF



REF.	CODE 1	CODE 2	CODE 3	CODE 4
PF 22	201010105030	100101100025	201101801002	100051040010
PF 27	201010125030	100101120030	201101801202	100051050012
PF 32	201010165020	100101160035	201101801402	100051060016
PF 40	201010210010	100101200045	201101801603	100051060018
PF 60	-	-	201101802510	100051120025

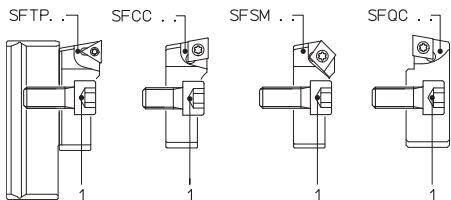
175

P 20.30



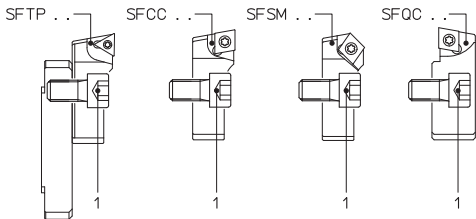
REF.	CODE 1
P20.30	100251080008

PS



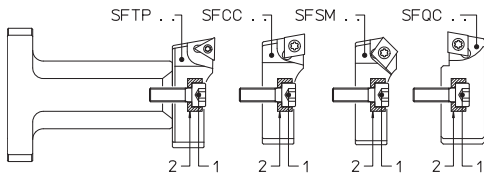
REF.	CODE 1
PS 11.30	100051100018
PS 12.30	
PS 13.30	
PS 11.40	100051100025
PS 12.40	
PS 13.40	
PS 14.40	

PS



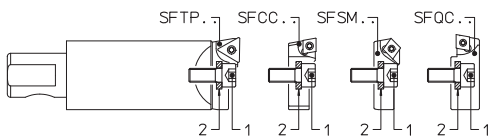
REF.	CODE1
PS31.24	100051100020
PS31.28	100051100025
PS32.28	
PS33.28	

P 22.28



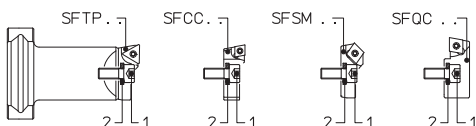
REF.	CODE 1	CODE 2
P22.28	100051060020	201040607001

P 25

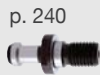


REF.	CODE 1	CODE 2
P25.63	100051050012	100800100530
P25.105		

P



REF.	CODE 1	CODE 2
P 00.30	100051050012	100800100530
P 03.30		
P 04.30		
P 02.40	100051060018	100800100640
P 03.40		
P 04.40		



p. 178 DIN 69893 HSK-A

p. 179 ISO 26623-1 PSC

p. 180 DIN 69871 AD+B

p. 181 MAS 403 BT AD+B

p. 182 DIN 69871 AD+B FC  
FACE CONTACT

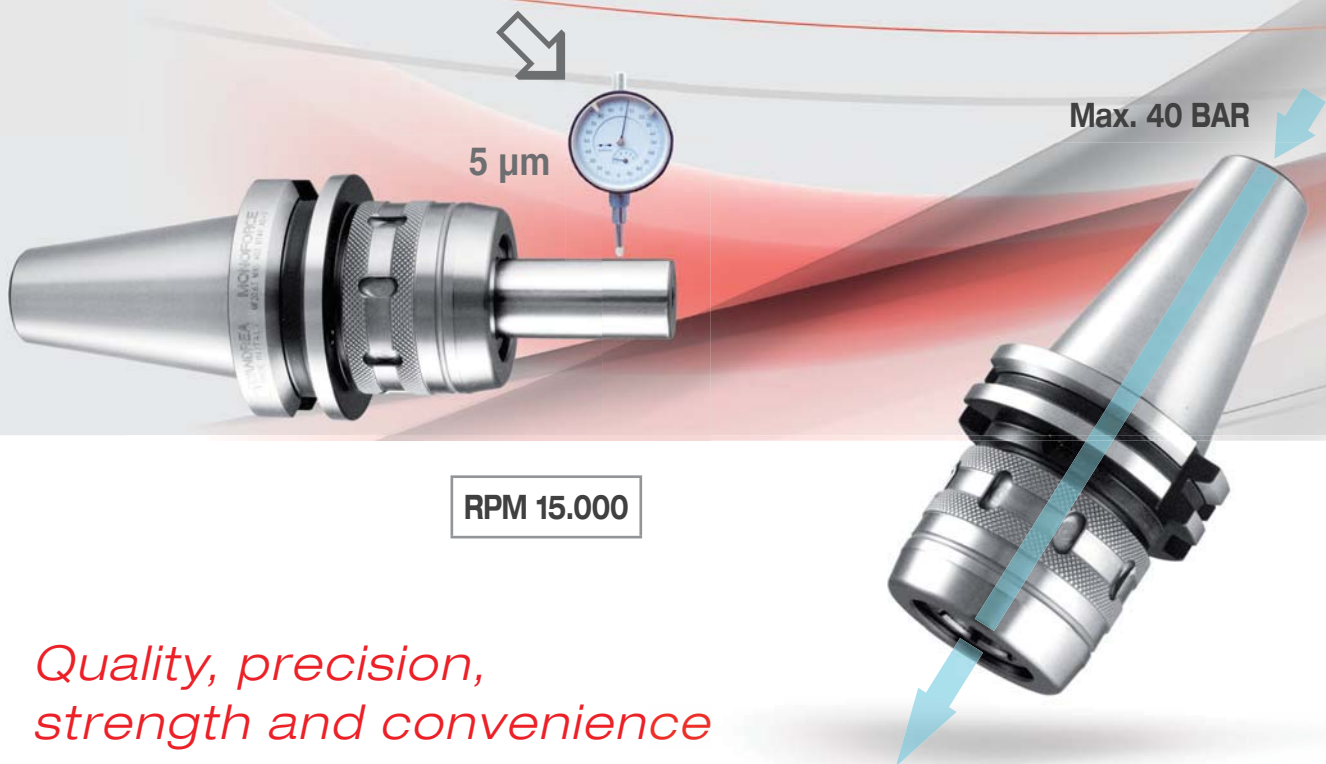
p. 183 MAS 403 BT AD+B FC  
FACE CONTACT

**KIT MONOFORCE**

p. 178 HSK  
p. 179 PSC  
p. 180 DIN  
p. 181 BT

p. 182 DIN FACE CONTACT  
p. 183 BT FACE CONTACT





*Quality, precision,  
strength and convenience*

- **HIGH PRECISION ULTRA-TIGHT TOOLHOLDER**
- **PRÄZISIONSSPANNZANGENFUTTER MIT HOCHFESTER WERKZEUGSPANNUNG**
- **PORTAHERRAMIENTAS DE PRECISIÓN DE FUERTE BLOCAJE**
- **PORTE-OUTIL DE PRÉCISION À SERRAGE FORT**
- **PORTAUTENSILE DI PRECISIONE A FORTE SERRAGGIO**

**GB MONOforce** is a addition to D'Andrea range of tool holders, which complements the existing balanceable FORCE chuck from Toprun family. This new chuck provides an economical and innovative solution for tool holding, where precision and high clamping forces for the cutting tool are required. MONOforce is available with tapers conforming to DIN 69871, MAS-BT, in ISO 40 and ISO 50 Ausführung sowie als HSK 63 und 100, ISO 26623-1 PSC 63 und 80. The chuck accepts reduction bushes to suit cutters having shank sizes ranging from Ø 3 mm. to Ø 25 mm. MONOforce can also be supplied in kit form, which includes of a set of reduction bushes and clamping wrench. MONOforce toolholders are manufactured by D'Andrea in their modern manufacturing plants in Italy.

**D MONOforce** ist eine Ergänzung zur D'Andrea Werkzeughalterserie und komplettiert die bestehende auswuchtbare FORCE-Spannzange aus der Toprun-Familie. Dieses neue innovative und wirtschaftliche Aufnahmefutter ist ausgelegt für Werkzeugspannungen, bei denen höchste Präzision und Spannkraft zur Klemmung von Fräswerkzeugen gefordert ist. MONOforce ist erhältlich mit Aufnahmekegeln nach DIN 69871, MAS-BT, in ISO 40 und ISO 50 Ausführung sowie als HSK 63 und 100, ISO 26623-1 PSC 63 und 80. Das Futter kann mittels Reduzierhülsen für Fräser von Ø 3 - 25 mm eingesetzt werden. MONOforce wird auch als Set angeboten inklusive Reduzierhülsen und Klemmschrauben. Alle MONOforce-Werkzeughalter werden in den modernen Produktionsstätten von D'Andrea in Italien hergestellt.

**E MONOforce** representa la solución ideal y económica para el equipamiento de todas las Máquinas Herramientas donde existen exigencias de precisión y necesidad de bloqueo de herramientas que necesitan elevadas cargas de torsión. MONOforce acompaña al ya famoso Force de la familia Toprun, el sistema patentado de portaherramientas integrales equilibrables. El programa MONOforce para husillos maquina HSK 63 y 100, ISO 26623-1 PSC 63 y 80, DIN 69871 y MAS-BT está realizado en los tamaños ISO 40 y ISO 50 con pinzas de reducción de Ø 12 mm, Ø 20 mm y de Ø 32 mm disponibles estándar en toda la gamma diametral compatible con estos diámetros de alojamientos para bloqueo de Ø 3 mm a Ø 25 mm. Los portaherramientas MONOforce, enteramente producidos por D'Andrea, están disponibles también en prácticos Kits completos con pinzas de reducción y llaves de bloqueo.

**F Le MONOforce** vient agrandir la série de produits D'Andréa dans la gamme des attachements appartenant à la famille Toprun et concernant les attachements équilibrables Force. Ce nouvel attachement est une solution économique et innovatrice dans le domaine des outils de serrage où précision et grande force de clamage sont nécessaires pour les outils coupants. MONOforce est disponible avec des cônes conformément aux normes DIN 69871, MAS-BT, in ISO 40, 50 et également HSK 63 et 100, ISO 26623-1 PSC 63 et 80. Les attachements acceptent des pinces de réduction afin de pouvoir appliquer des outils coupants ayant des queues entre Ø 3 et Ø 25 mm. MONOforce peut être fourni en kit, comprenant un set de pinces de réduction ainsi que la clé de serrage. Les attachements MONOforce sont fabriqués par D'Andréa dans leur nouvelle usine située en Italie.

**I MONOforce** rappresenta la soluzione ideale ed economica per l'attrezzatura di tutte le macchine utensili ove sussistano esigenze di precisione e necessità di serraggio utensili sollecitati a elevati carichi torsionali. MONOforce si affianca al già noto Force della famiglia Toprun, il sistema brevettato di portautensili integrali bilanciabili. Il programma MONOforce è costruito nella versione per mandrini macchina HSK 63 e 100, ISO 26623-1 PSC 63 e 80, nonché DIN 69871 e MAS-BT realizzati nelle grandezze ISO 40 e 50 e permette l'impiego di bussole di riduzione da Ø 12 mm, Ø 20 mm e Ø 32 mm. disponibili standard in tutta la gamma diametrale compatibile con questi diametri d'alloggiamento per serraggi da Ø 3 mm a Ø 25 mm. I portautensili MONOforce – interamente prodotti dalla D'Andrea – sono disponibili anche in pratici kit completi di bussole di riduzione e chiave di serraggio.

- HIGH PRECISION ULTRA-TIGHT TOOLHOLDER
- PRÄZISIONSSPANNZANGENFUTTER MIT HOCHFESTER WERKZEUGSPANNUNG
- PORTAHERRAMIENTAS DE PRECISIÓN DE FUERTE BLOCAJE
- PORTE-OUTIL DE PRÉCISION À SERRAGE FORT
- PORTAUTENSILE DI PRECISIONE A FORTE SERRAGGIO

## DIN 69893 HSK-A

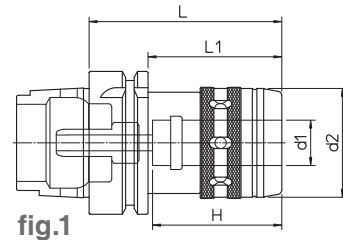


fig.1

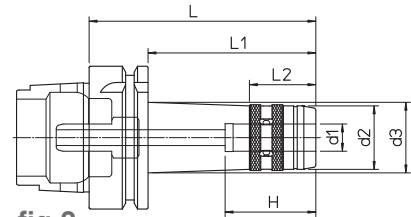


fig.2

- Supplied with coolant tube - without clamping wrench
- Lieferung inklusive Kühlmittelrohr. Ohne Spannzangen und Spannschlüssel.
- Completo con racor para el refrigerante - Llave de apriete excluida
- Pourvu de raccord pour liquide d'arrosage - Sans clef de serrage
- Completo di raccordo per il refrigerante - chiave di serraggio esclusa

HSK-A	REF.	CODE	d1	d2	d3	H	L	L1	L2	kg	fig.	
63	HSK-A63 MF12.70	71HSK-A63MF1207	12	28	-	46	70	44	-	0.8	1	
	HSK-A63 MF12.100	71HSK-A63MF1210			32		100	74	29.5	1.1	2	
	HSK-A63 MF20.85	71HSK-A63MF2008	20	48	-	60	85	59	-	1.2	1	
	HSK-A63 MF20.125	71HSK-A63MF2012					125	99		1.7	2	
	HSK-A63 MF32.105	71HSK-A63MF3210	32	66	-	80	105	-	-	2	1	
	HSK-A63 MF32.140	71HSK-A63MF3214					140	-		2.6	2	
100	HSK-A100 MF32.110	71HSKA100MF3211					110	81		-	3.1	1
	HSK-A100 MF32.160	71HSKA100MF3216					160	131			3.6	

## KIT K01 HSK-A63



### K01 MONOforce 12 K01 MONOforce 20 KIT K01 MONOforce 32

1 MONOforce 12	1 MONOforce 20	1 MONOforce 32
1 RC 12.04	1 RC 20.06	1 RC 32.06
1 RC 12.06	1 RC 20.08	1 RC 32.08
1 RC 12.08	1 RC 20.10	1 RC 32.10
1 RC 12.10	1 RC 20.12	1 RC 32.12
1 CHV 28	1 RC 20.16	1 RC 32.16
	1 CHV 50	1 RC 32.20
		1 RC 32.25
		1 CHV 75

HSK-A	REF.	CODE
63	KIT K01 MONOFORCE 12.70 HSK63	7KHSK-A63MF1207
	KIT K01 MONOFORCE 20.85 HSK63	7KHSK-A63MF2008
	KIT K01 MONOFORCE 32.105 HSK63	7KHSK-A63MF3210

## KIT K01 HSK-A100



### K01 MONOforce 20 KIT K01 MONOforce 32

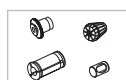
1 MONOforce 20	1 MONOforce 32
1 RC 20.06	1 RC 32.06
1 RC 20.08	1 RC 32.08
1 RC 20.10	1 RC 32.10
1 RC 20.12	1 RC 32.12
1 RC 20.16	1 RC 32.16
1 CHV 50	1 RC 32.20
	1 RC 32.25
	1 CHV 75

HSK-A	REF.	CODE
100	KIT K01 MONOFORCE 32.110 HSK100	7KHSKA100MF3211

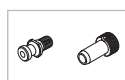
248



241



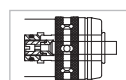
240



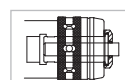
222



222



222





- HIGH PRECISION ULTRA-TIGHT TOOLHOLDER
- PRÄZISIONSSPANNZANGENFUTTER MIT HOCHFESTER WERKZEUGSPANNUNG
- PORTAHERRAMIENTAS DE PRECISIÓN DE FUERTE BLOCAJE
- PORTE-OUTIL DE PRÉCISION À SERRAGE FORT
- PORTAUTENSILE DI PRECISIONE A FORTE SERRAGGIO

## ISO 26623-1 PSC

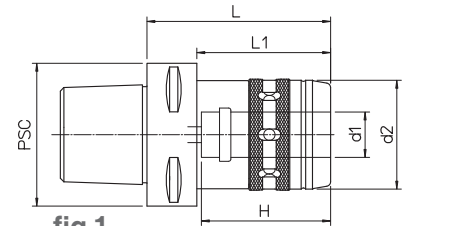


fig.1

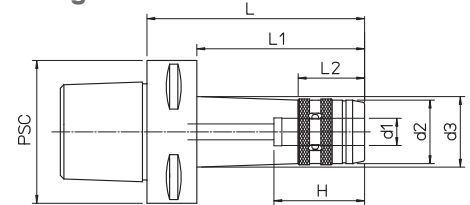


fig.2

- Without clamping wrench
- Ohne Spannschlüssel.
- Llave de apriete excluida
- Sans clef de serrage
- Chiave di serraggio esclusa

PSC	REF.	CODE	d1	d2	d3	H	L	L1	L2	kg	fig.		
63	PSC 63 - MF 12.70	71PSC-063MF1207	12	28	-	46	70	48	-	0.9	1		
	PSC 63 - MF 12.100	71PSC-063MF1210			31.5		100	78	29.5	1.4	2		
	PSC 63 - MF 20.80	71PSC-063MF2008	20	48	-		80	58	-	1.3	1		
	PSC 63 - MF 20.120	71PSC-063MF2012					120	98		1.9	2		
	PSC 63 - MF 32.100	71PSC-063MF3210	32	66			80	100		-	2.1	1	
	PSC 63 - MF 32.140	71PSC-063MF3214					140	-		3.1	2		
80	PSC 80 - MF 20.80	71PSC-080MF2008	20	48		-	60	80		50	-	3.7	1
	PSC 80 - MF 20.125	71PSC-080MF2012					125	95		4.1		2	
	PSC 80 - MF 32.100	71PSC-080MF3210	32	66	80		100	70	4.4	1			
	PSC 80 - MF 32.160	71PSC-080MF3216			160		130	4.9	2				



### K01 MONOforce 12 K01 MONOforce 20 KIT K01 MONOforce 32

1 MONOforce 12	1 MONOforce 20	1 MONOforce 32
1 RC 12.04	1 RC 20.06	1 RC 32.06
1 RC 12.06	1 RC 20.08	1 RC 32.08
1 RC 12.08	1 RC 20.10	1 RC 32.10
1 RC 12.10	1 RC 20.12	1 RC 32.12
1 CHV 28	1 RC 20.16	1 RC 32.16
	1 CHV 50	1 RC 32.20
		1 RC 32.25
		1 CHV 75

PSC	REF.	CODE
63	KIT K01 MONOFORCE 12.70 PSC 63	7KPSC-063MF1207
	KIT K01 MONOFORCE 20.80 PSC 63	7KPSC-063MF2008
	KIT K01 MONOFORCE 32.100 PSC 63	7KPSC-063MF3210

## KIT K01

### ISO 26623-1 PSC 63



### K01 MONOforce 20 KIT K01 MONOforce 32

1 MONOforce 20	1 MONOforce 32
1 RC 20.06	1 RC 32.06
1 RC 20.08	1 RC 32.08
1 RC 20.10	1 RC 32.10
1 RC 20.12	1 RC 32.12
1 RC 20.16	1 RC 32.16
1 CHV 50	1 RC 32.20
	1 RC 32.25
	1 CHV 75

PSC	REF.	CODE
80	KIT K01 MONOFORCE 20.80 PSC 80	7KPSC-080MF2008
	KIT K01 MONOFORCE 32.100 PSC 80	7KPSC-080MF3210

## KIT K01

### ISO 26623-1 PSC 80





- HIGH PRECISION ULTRA-TIGHT TOOLHOLDER
- PRÄZISIONSSPANNZANGENFUTTER MIT HOCHFESTER WERKZEUGSPANNUNG
- PORTAHERRAMIENTAS DE PRECISIÓN DE FUERTE BLOCAJE
- PORTE-OUTIL DE PRÉCISION À SERRAGE FORT
- PORTAUTENSILE DI PRECISIONE A FORTE SERRAGGIO

## DIN 69871 AD+B

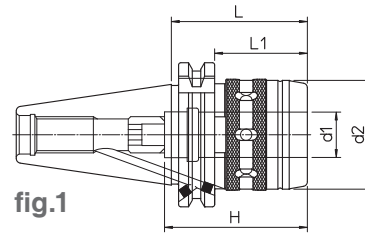


fig.1

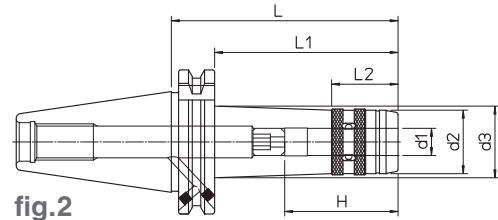


fig.2

- Without clamping wrench
- Ohne Spannschlüssel.
- Llave de apriete excluida
- Sans clef de serrage
- Chiave di serraggio esclusa

DIN	REF.	CODE	d1	d2	d3	H	L	L1	L2	kg	fig.	
40	DIN69871-AD+B40 MF12.50	71DIN-B40MF1205	12	28	-	46	50	31	-	0.8	1	
	DIN69871-AD+B40 MF12.100	71DIN-B40MF1210			32		100	81	29.5	1.2	2	
	DIN69871-AD+B40 MF20.60	71DIN-B40MF2006	20	48	-	63	60	41	-	1.1	1	
	DIN69871-AD+B40 MF20.100	71DIN-B40MF2010					100	81	-	1.4	2	
	DIN69871-AD+B40 MF32.95	71DIN-B40MF3209	32	66		80	95	-	-	1.6	1	
	DIN69871-AD+B40 MF32.140	71DIN-B40MF3214					140	-	-	2.0	2	
50	DIN69871-AD+B50 MF20.80	71DIN-B50MF2008	20	48		-	63	80	61	-	2.3	1
	DIN69871-AD+B50 MF20.125	71DIN-B50MF2012						125	106	-	2.7	2
	DIN69871-AD+B50 MF32.75	71DIN-B50MF3207	32	66	90		75	56	-	2.8	1	
	DIN69871-AD+B50 MF32.160	71DIN-B50MF3216					160	141	-	3.2	2	



### K01 MONOforce 12 K01 MONOforce 20 KIT K01 MONOforce 32

1 MONOforce 12	1 MONOforce 20	1 MONOforce 32
1 RC 12.04	1 RC 20.06	1 RC 32.06
1 RC 12.06	1 RC 20.08	1 RC 32.08
1 RC 12.08	1 RC 20.10	1 RC 32.10
1 RC 12.10	1 RC 20.12	1 RC 32.12
1 CHV 28	1 RC 20.16	1 RC 32.16
	1 CHV 50	1 RC 32.20
		1 RC 32.25
		1 CHV 75

### KIT K01 DIN-A40

DIN	REF.	CODE
40	KIT K01 MONOFORCE 12.50 DIN40AD+B	7KDIN-B40MF1205
	KIT K01 MONOFORCE 20.60 DIN40AD+B	7KDIN-B40MF2006
	KIT K01 MONOFORCE 32.95 DIN40AD+B	7KDIN-B40MF3209



### K01 MONOforce 20 KIT K01 MONOforce 32

1 MONOforce 20	1 MONOforce 32
1 RC 20.06	1 RC 32.06
1 RC 20.08	1 RC 32.08
1 RC 20.10	1 RC 32.10
1 RC 20.12	1 RC 32.12
1 RC 20.16	1 RC 32.16
1 CHV 50	1 RC 32.20
	1 RC 32.25
	1 CHV 75

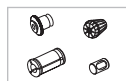
### KIT K01 DIN-A50

DIN	REF.	CODE
50	KIT K01 MONOFORCE 20.80 DIN50AD+B	7KDIN-B50MF2008
	KIT K01 MONOFORCE 32.75 DIN50AD+B	7KDIN-B50MF3207

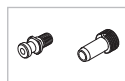
249



241



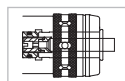
240



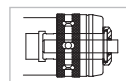
222



222



222

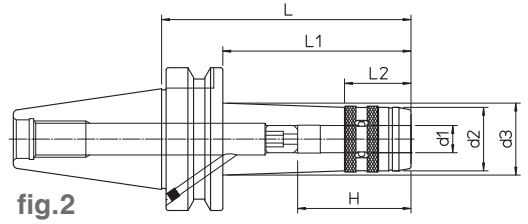
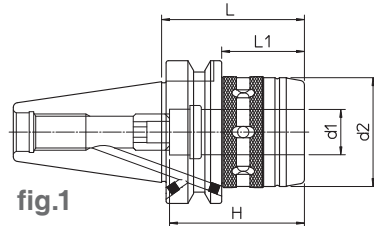


- HIGH PRECISION ULTRA-TIGHT TOOLHOLDER
- PRÄZISIONSSPANNZANGENFUTTER MIT HOCHFESTER WERKZEUGSPANNUNG
- PORTAHERRAMIENTAS DE PRECISIÓN DE FUERTE BLOCAJE
- PORTE-OUTIL DE PRÉCISION À SERRAGE FORT
- PORTAUTENSILE DI PRECISIONE A FORTE SERRAGGIO

## MAS 403 BT AD+B



- Without clamping wrench
- Ohne Spannschlüssel.
- Llave de apriete excluida
- Sans clef de serrage
- Chiave di serraggio esclusa



BT	REF.	CODE	d1	d2	d3	H	L	L1	L2	kg	fig.		
40	MAS403 BT40-AD+B MF12.60	71MBT-B40MF1206	12	28	-	46	60	33	-	0.9	1		
	MAS403 BT40-AD+B MF12.100	71MBT-B40MF1210			32		100	73	29.5	1.4	2		
	MAS403 BT40-AD+B MF20.63	71MBT-B40MF2006	20	48	-	63	63	36	-	1.3	1		
	MAS403 BT40-AD+B MF20.100	71MBT-B40MF2010					100	73		1.9	2		
	MAS403 BT40-AD+B MF32.90	71MBT-B40MF3209	32	66		80	90	-		2.1	1		
	MAS403 BT40-AD+B MF32.140	71MBT-B40MF3214					140	-		3.1	2		
50	MAS403 BT50-AD+B MF20.85	71MBT-B50MF2008	20	48		-	63	85		47	-	3.7	1
	MAS403 BT50-AD+B MF20.125	71MBT-B50MF2012						125		87		4.1	2
	MAS403 BT50-AD+B MF32.95	71MBT-B50MF3209	32	66	90		95	57	4.4	1			
	MAS403 BT50-AD+B MF32.160	71MBT-B50MF3216					160	122	4.9	2			



### K01 MONOforce 12 K01 MONOforce 20 KIT K01 MONOforce 32

1 MONOforce 12	1 MONOforce 20	1 MONOforce 32
1 RC 12.04	1 RC 20.06	1 RC 32.06
1 RC 12.06	1 RC 20.08	1 RC 32.08
1 RC 12.08	1 RC 20.10	1 RC 32.10
1 RC 12.10	1 RC 20.12	1 RC 32.12
1 CHV 28	1 RC 20.16	1 RC 32.16
	1 CHV 50	1 RC 32.20
		1 RC 32.25
		1 CHV 75

### KIT K01 BT 40

BT	REF.	CODE
40	KIT K01 MONOFORCE 12.60 BT40AD+B	7KMBT-B40MF1206
	KIT K01 MONOFORCE 20.63 BT40AD+B	7KMBT-B40MF2006
	KIT K01 MONOFORCE 32.90 BT40AD+B	7KMBT-B40MF3209

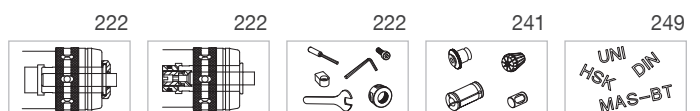


### K01 MONOforce 20 KIT K01 MONOforce 32

1 MONOforce 20	1 MONOforce 32
1 RC 20.06	1 RC 32.06
1 RC 20.08	1 RC 32.08
1 RC 20.10	1 RC 32.10
1 RC 20.12	1 RC 32.12
1 RC 20.16	1 RC 32.16
1 CHV 50	1 RC 32.20
	1 RC 32.25
	1 CHV 75

### KIT K01 BT 50

BT	REF.	CODE
50	KIT K01 MONOFORCE 20.85 BT50AD+B	7KMBT-B50MF2008
	KIT K01 MONOFORCE 32.95 BT50AD+B	7KMBT-B50MF3209



# D'ANDREA

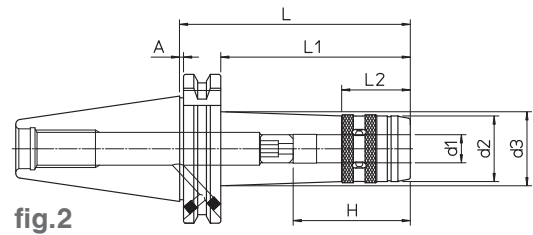
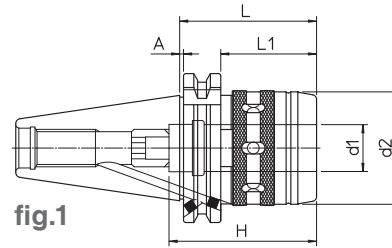
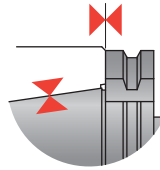
## MONOforce

### FACE CONTACT

- HIGH PRECISION ULTRA-TIGHT TOOLHOLDER
- PRÄZISIONSSPANNZANGENFUTTER MIT HOCHFESTER WERKZEUGSPANNUNG
- PORTAHERRAMIENTAS DE PRECISIÓN DE FUERTE BLOCAJE
- PORTE-OUTIL DE PRÉCISION À SERRAGE FORT
- PORTAUTENSILE DI PRECISIONE A FORTE SERRAGGIO

### DIN 69871 FC

#### FACE CONTACT AD+B



- Without clamping wrench
- Ohne Spannschlüssel.
- Llave de apriete excluida
- Sans clef de serrage
- Chiave di serraggio esclusa

DIN	REF.	CODE	d1	d2	d3	H	A	L	L1	L2	kg	fig.	
40	DIN69871-AD+B40 FC MF12.50	71DIF-B40MF1205	12	28	-	46	1	50	31	-	0.8	1	
	DIN69871-AD+B40 FC MF12.100	71DIF-B40MF1210			32					29.5			1.2
	DIN69871-AD+B40 FC MF20.60	71DIF-B40MF2006	20	48	-					60	41	1.1	1
	DIN69871-AD+B40 FC MF20.100	71DIF-B40MF2010			100					81	1.4	2	
	DIN69871-AD+B40 FC MF32.95	71DIF-B40MF3209	32	66	-					80	-	1.6	1
	DIN69871-AD+B40 FC MF32.140	71DIF-B40MF3214			140					-	2.0	2	
50	DIN69871-AD+B50 FC MF20.80	71DIF-B50MF2008	20	48	-	63	1.5	80	61	-	2.3	1	
	DIN69871-AD+B50 FC MF20.125	71DIF-B50MF2012			125			106	2.7	2			
	DIN69871-AD+B50 FC MF32.75	71DIF-B50MF3207	32	66	-			90	56	2.8	1		
	DIN69871-AD+B50 FC MF32.160	71DIF-B50MF3216			160			141	3.2	2			



<b>K01 MONOforce 12 FC</b>	<b>K01 MONOforce 20 FC</b>	<b>K01 MONOforce 32 FC</b>
1 MONOforce 12	1 MONOforce 20	1 MONOforce 32
1 RC 12.04	1 RC 20.06	1 RC 32.06
1 RC 12.06	1 RC 20.08	1 RC 32.08
1 RC 12.08	1 RC 20.10	1 RC 32.10
1 RC 12.10	1 RC 20.12	1 RC 32.12
1 CHV 28	1 RC 20.16	1 RC 32.16
	1 CHV 50	1 RC 32.20
		1 RC 32.25
		1 CHV 75

### KIT K01

#### DIN-A40

DIN	REF.	CODE
40	KIT K01 MONOFORCE 12.50 DIN40AD+B FC	7KDIF-B40MF1205
	KIT K01 MONOFORCE 20.60 DIN40AD+B FC	7KDIF-B40MF2006
	KIT K01 MONOFORCE 32.95 DIN40AD+B FC	7KDIF-B40MF3209



<b>K01 MONOforce 20 FC</b>	<b>K01 MONOforce 32 FC</b>
1 MONOforce 20	1 MONOforce 32
1 RC 20.06	1 RC 32.06
1 RC 20.08	1 RC 32.08
1 RC 20.10	1 RC 32.10
1 RC 20.12	1 RC 32.12
1 RC 20.16	1 RC 32.16
1 CHV 50	1 RC 32.20
	1 RC 32.25
	1 CHV 75

### KIT K01

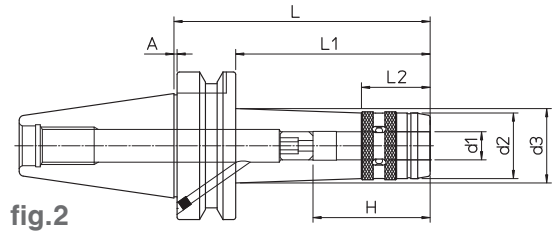
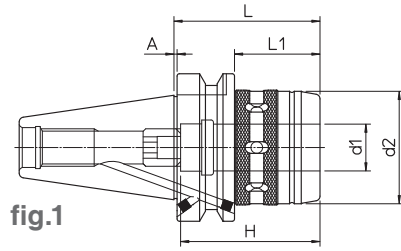
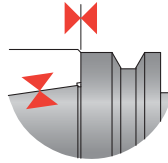
#### DIN-A50

DIN	REF.	CODE
50	KIT K01 MONOFORCE 20.80 DIN50AD+B FC	7KDIF-B50MF2008
	KIT K01 MONOFORCE 32.75 DIN50AD+B FC	7KDIF-B50MF3207



- HIGH PRECISION ULTRA-TIGHT TOOLHOLDER
- PRÄZISIONSSPANNZANGENFUTTER MIT HOCHFESTER WERKZEUGSPANNUNG
- PORTAHERRAMIENTAS DE PRECISIÓN DE FUERTE BLOCAJE
- PORTE-OUTIL DE PRÉCISION À SERRAGE FORT
- PORTAUTENSILE DI PRECISIONE A FORTE SERRAGGIO

**MAS 403 BT FC**  
FACE CONTACT AD+B



- Without clamping wrench
- Ohne Spannschlüssel.
- Llave de apriete excluida
- Sans clef de serrage
- Chiave di serraggio esclusa

BT	REF.	CODE	d1	d2	d3	H	A	L	L1	L2	kg	fig.						
40	MAS403 BT40 FC AD+B MF12.60	71MBF-B40MF1206	12	28	-	46	1	60	33	-	0.9	1						
	MAS403 BT40 FC AD+B MF12.100	71MBF-B40MF1210			32					29.5			1.4	2				
	MAS403 BT40 FC AD+B MF20.63	71MBF-B40MF2006	20	48	-	63				36	1.3	1						
	MAS403 BT40 FC AD+B MF20.100	71MBF-B40MF2010								73			1.9	2				
	MAS403 BT40 FC AD+B MF32.90	71MBF-B40MF3209	32	66						-	80	90	2.1	1				
	MAS403 BT40 FC AD+B MF32.140	71MBF-B40MF3214										140			3.1	2		
50	MAS403 BT50 FC AD+B MF20.85	71MBF-B50MF2008	20	48			-	63	1.5		85	47	-	3.7	1			
	MAS403 BT50 FC AD+B MF20.125	71MBF-B50MF2012														87	4.1	2
	MAS403 BT50 FC AD+B MF32.95	71MBF-B50MF3209	32	66	-	90		-						95	57	-	4.4	1
	MAS403 BT50 FC AD+B MF32.160	71MBF-B50MF3216																



- K01 MONOforce 12 FC**   **K01 MONOforce 20 FC**   **K01 MONOforce 32 FC**
- |                |                |                |
|----------------|----------------|----------------|
| 1 MONOforce 12 | 1 MONOforce 20 | 1 MONOforce 32 |
| 1 RC 12.04     | 1 RC 20.06     | 1 RC 32.06     |
| 1 RC 12.06     | 1 RC 20.08     | 1 RC 32.08     |
| 1 RC 12.08     | 1 RC 20.10     | 1 RC 32.10     |
| 1 RC 12.10     | 1 RC 20.12     | 1 RC 32.12     |
| 1 CHV 28       | 1 RC 20.16     | 1 RC 32.16     |
|                | 1 CHV 50       | 1 RC 32.20     |
|                |                | 1 RC 32.25     |
|                |                | 1 CHV 75       |

**KIT K01**  
**BT 40**

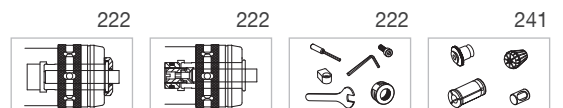
BT	REF.	CODE
40	KIT K01 MONOFORCE 12.60 BT40AD+B FC	7KMBF-B40MF1206
	KIT K01 MONOFORCE 20.63 BT40AD+B FC	7KMBF-B40MF2006
	KIT K01 MONOFORCE 32.90 BT40AD+B FC	7KMBF-B40MF3209



- K01 MONOforce 20 FC**   **K01 MONOforce 32 FC**
- |                |                |
|----------------|----------------|
| 1 MONOforce 20 | 1 MONOforce 32 |
| 1 RC 20.06     | 1 RC 32.06     |
| 1 RC 20.08     | 1 RC 32.08     |
| 1 RC 20.10     | 1 RC 32.10     |
| 1 RC 20.12     | 1 RC 32.12     |
| 1 RC 20.16     | 1 RC 32.16     |
| 1 CHV 50       | 1 RC 32.20     |
|                | 1 RC 32.25     |
|                | 1 CHV 75       |

**KIT K01**  
**BT 50**

BT	REF.	CODE
50	KIT K01 MONOFORCE 20.85 BT50AD+B FC	7KMBF-B50MF2008
	KT K01 MONOFORCE 32.95 BT50AD+B FC	7KMBF-B50MF3209



*High speed, balancing and precision*

 0.003



p. 240



p. 186

**DIN 69893 HSK-A**  
ER  
FORCE  
**DIN 69893 HSK-E**  
ER  
FORCE

p. 240



p. 188

**DIN 69871-A**  
ER  
FORCE

p. 240



p. 190

**MAS 403 BT**  
ER  
FORCE



p. 187  
p. 189  
p. 191

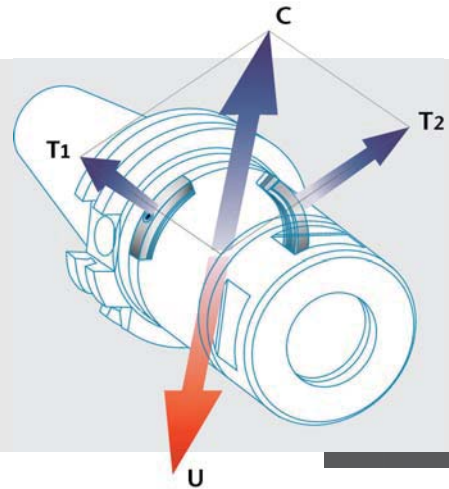
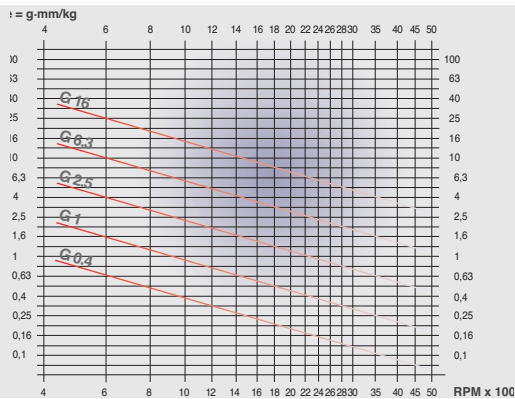
**KIT FORCE**  
HSK  
DIN  
BT





- **BALANCEABLE TOOLHOLDERS - BALANCING AND PRECISION**
- **AUSWUCHTBARE WERKZEUGAUFNAHMEN - AUSWUCHTEN UND PRÄZISION**
- **PORTAHERRAMIENTAS EQUILIBRABLES PARA ALTA VELOCIDAD**
- **PORTE-OUTILS ÉQUILIBRABLES POUR HAUTE VITESSE**
- **PORTAUTENSILI BILANCIABILI PER ALTA VELOCITÀ**

**GB** The use of **TOPRUN** balanceable toolholders provides the following advantages: considerable extension of spindle bearings life; considerable extension of tool life; improved accuracy and surface finish; drastic reduction of vibrations and noise level of the machining centre. For high speed machining with Toprun toolholders, the two counterweights in the graduated groove (patented) have to be positioned following the indications provided by the electronic balancing unit; a quick and easy balancing of the toolholder complete with tension rod and tool according to the ISO 1940/1 standards. For machining up to 8,000 rpm it is sufficient to position the counterweights at 0° and at 180°. **BALANCING.** The balancing operation has the aim to bring the original unbalance "U" within the maximum admissible level "G". The manufacturers of high speed milling machines usually prescribe a balancing level "G 1" or "G 2.5" for the toolholders to be used on their machines according to the ISO 1940/1 standard. Specifically, the original unbalance "U" of the tool and toolholder is neutralized by the resulting centrifugal force "C" produced by the two balancing masses "T1" and "T2".



**D** Der Einsatz von ausgewuchteten **TOPRUN** Werkzeugen bietet folgende Vorteile: Schonung der Spindel-Lagerung, dadurch deutlich höhere Lebensdauer; wesentlich höhere Lebensdauer der Werkzeuge und Schneidwerkzeuge; verbesserte Genauigkeit und Oberflächenfertigung (Qualität); erhebliche Verminderung von Vibrationen und Geräuschen am Bearbeitungszentrum. Um eine bestmögliche Leistung der Toprun Werkzeughalter in Hochgeschwindigkeits-bereichen zu erzielen, wird wie folgt verfahren: die zwei Gegengewichte werden in der T-Nut am Umfang des Werkzeuges nach Angaben des elektronischen Auswuchtgerätes positioniert. Ein paar einfache Handgriffe ermöglichen dann die komplette Auswuchtung des Werkzeuges samt Anzugsbolzen und Schneidwerkzeug nach ISO 1940/1. Für Maschinen bis 8000 Drehzahlen/Min. genügt es, die Gewichte auf 0° und 180° zu positionieren. **AUSWUCHTEN.** Das Ziel des Auswuchtens von Werkzeughaltern ist, die ursprüngliche Unwucht "U" auf das maximale zugelassene "G" Niveau zu reduzieren. Die Hersteller von Hochgeschwindigkeitsfräsmaschinen schreiben eine Wuchtgüte von "G1" oder "G2,5" entsprechend ISO 1940/1 Standard für die verwendeten Werkzeuge ihrer Maschinen vor. Die grundlegende Unwucht "U" des Werkzeuges und der Werkzeugaufnahme wird durch die Zentrifugalkraft "C" neutralisiert, die durch die richtig angeordneten Gegengewichte "T1" und "T2" am Umfang der Werkzeugaufnahme entsteht.

**E** La utilización de los portaherramientas **TOPRUN** equilibrados tiene las siguientes ventajas: prolonga la vida del husillo del centro de mecanizado; aumenta la duración de la herramienta; mejora la precisión y la calidad de las superficies mecanizadas; reduce las vibraciones y la rumorosidad del centro de mecanizado. Para la utilización de los portaherramientas Toprun en máquinas de alta velocidad, los dos contrapesos insertados en la ranura circular graduada (patentada) deben ser posicionados según las indicaciones indicadas por el equipo electrónico de equilibrado; esto garantiza un rápido equilibrado del portaherramientas completo con tirante y herramienta, respetando las especificaciones ISO 1940/1. Para trabajar hasta 8.000 RPM es suficiente posicionar los contrapesos a 0° y 180°. **EQUILIBRADO.** La operación de equilibrado consiste en reducir el desequilibrio "U" existente en el portaherramientas, llevándolo dentro del valor máximo admisible, definido por el grado de equilibrio "G". Normalmente los constructores de máquinas de alta velocidad piden montar portaherramientas equilibrados con un grado "G1" o bien "G2,5" que hace referencia a la norma ISO 1940/1. En lo específico, el equilibrado se obtiene de esta forma: el desequilibrio "U" presente originariamente en el conjunto de portaherramientas y herramienta se compensa por la resultante "C" de las fuerzas centrífugas generadas por los contrapesos "T1" y "T2", la posición de los cuales viene indicada por una máquina equilibradora.

**F** L'utilisation des porte-outils équilibrables **TOPRUN** apporte les avantages suivants: meilleure durée de vie des roulements de broche; meilleure durée de vie de l'outil; amélioration de la précision et meilleur état de surface; réduction des vibrations et de bruit. En usinage haute vitesse, pour obtenir les meilleures performances avec les porte-outils Toprun, les deux contrepoids doivent être positionnés dans la rainure circulaire graduée (breveté) en suivant les instructions fournies par l'unité électronique d'équilibrage. Un équilibrage rapide et facile de l'ensemble porte-outil, tirette et outil coupant est ainsi obtenu selon les normes ISO 1940/1. Pour une vitesse de broche de 8.000 RPM, il suffit de positionner les contrepoids à 0° et 180°. **EQUILIBRAGE.** L'équilibrage d'un porte-outils consiste à porter le "U" d'origine non équilibré au grade "G" maximum admissible. Les fabricants de machines à haute vitesse recommandent le grade "G1" ou "G 2,5", prescrits par les normes ISO 1940/1, pour les porte-outils utilisés sur leurs machines. Le "U" d'origine non équilibré de l'outil et du porte-outils est neutralisé par la résultante de la force centrifuge "C" produite par les deux masses d'équilibrage "T1" et "T2".

**I** L'utilizzo dei portautensili **TOPRUN** bilanciati dà i seguenti vantaggi: allunga la vita del mandrino del centro di lavoro; aumenta la durata dell'utensile; migliora la precisione e la qualità delle superfici lavorate; riduce le vibrazioni e la rumorosità del centro di lavoro. Per l'utilizzo dei portautensili Toprun su macchine ad alta velocità, i due tasselli inseriti nella gola circolare graduata (brevettato) devono essere posizionati secondo le indicazioni date dall'apparecchiatura elettronica di bilanciatura, nel rispetto delle specifiche ISO 1940/1. Per lavorare sino a 8.000 RPM è sufficiente posizionare i tasselli a 0° e a 180°. **EQUILIBRATURA.** L'operazione di equilibratura consiste nel ridurre lo squilibrio "U" esistente nel portautensile, portandolo entro il valore massimo ammissibile definito dal grado di equilibratura "G". Normalmente i costruttori di macchine ad alta velocità richiedono di montare portautensili bilanciati con un grado "G 1" oppure "G 2,5" in riferimento alla norma ISO 1940/1. Nello specifico la bilanciatura avviene in questo modo: lo squilibrio "U" presente originariamente nell'insieme di portautensile e utensile viene compensato dalla risultante "C" delle forze centrifughe generate dai tasselli "T1" e "T2", la posizione dei quali viene indicata da una macchina equilibratrice.



## DIN 69893 HSK-A

ER - DIN 6499

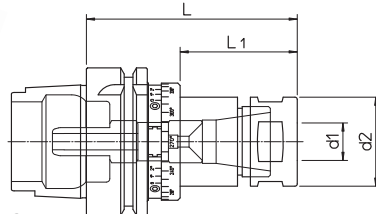


fig.1

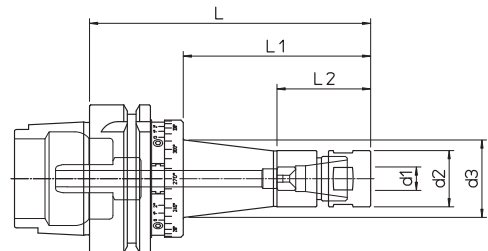


fig.2

- Supplied with coolant tube - without collets and clamping wrenches. The ring-nuts of the Toprun spindles allow the use of the ER collets with a working range of 0,5 mm.
- Lieferung inklusive Kühlmittelrohr. Ohne Spannzangen und Spannschlüssel. Die Spannmutter dieser Toprun-Aufnahmen sind für ER Spannzangen mit einem Arbeitsbereich von 0,5 mm vorgesehen.
- Completo con racor para el refrigerante - Pinzas elásticas y llaves de apriete excluidas. Las tuercas de los mandrinos Toprun permiten el empleo de las pinzas ER con un campo de trabajo de 0,5 mm.
- Pourvu de raccord pour liquide d'arrosage - Sans pinces et clés de serrage. Les bagues des mandrins Toprun permettent l'usage des pinces ER avec une capacité d'usinage de 0,5 mm.
- Completo di raccordo per il refrigerante - Pinze elastiche e chiavi di serraggio escluse. Le ghiera dei mandrini Toprun permettono l'impiego delle pinze ER con un campo di lavoro di 0,5 mm.

HSK-A	REF.	CODE	TYPE	d1	d2	d3	L	L1	L2	kg	fig.
63	HSK-A63 ER16.80	410101656320	ER 16	0.5 ~ 10	24	-	80	40	-	0.9	1
	HSK-A63 ER16.120	410121656320				34	120	80	40	1.1	2
	HSK-A63 ER25.80	410082556320	ER 25	1 ~ 16	38	-	80	40	-	1.2	1
	HSK-A63 ER25.140	410122556320				45	140	100	50	1.6	2
	HSK-A63 ER32.90	410083256320	ER 32	2 ~ 20	50	-	90	-	-	1.5	1

## DIN 69893 HSK-E

ER - DIN 6499

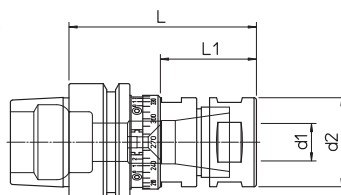


fig.1

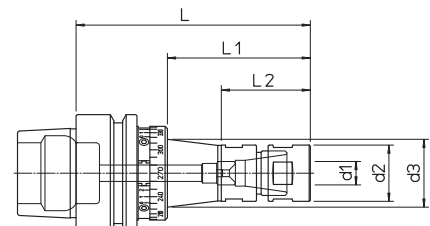


fig.2

- Supplied without collets and clamping wrenches. The ring-nuts of the Toprun spindles allow the use of the ER collets with a working range of 0,5 mm.
- Ohne Spannzangen und Spannschlüssel. Die Spannmutter dieser Toprun-Aufnahmen sind für ER Spannzangen mit einem Arbeitsbereich von 0,5 mm vorgesehen.
- Pinzas elásticas y llaves de apriete excluidas. Las tuercas de los mandrinos Toprun permiten el empleo de las pinzas ER con un campo de trabajo de 0,5 mm.
- Sans pinces et clés de serrage. Les bagues des mandrins Toprun permettent l'usage des pinces ER avec une capacité d'usinage de 0,5 mm.
- Pinze elastiche e chiavi di serraggio escluse. Le ghiera dei mandrini Toprun permettono l'impiego delle pinze ER con un campo di lavoro di 0,5 mm.

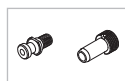
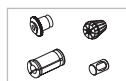
HSK-E	REF.	CODE	TYPE	d1	d2	d3	L	L1	L2	kg	fig.
40	HSK-E40 ER16.60	410101654025	ER 16	0.5 ~ 10	24	-	60	28.5	-	0.3	1
	HSK-E40 ER16.100	410121654025				28	100	68.5	36	0.4	2
	HSK-E40 ER25.70	410102554025	ER 25	1 ~ 16	38	-	70	-	-	0.7	1
50	HSK-E50 ER16.70	410081655025	ER 16	0.5 ~ 10	24	-	-	31	-	0.6	1
	HSK-E50 ER16.100	410121655025				29	100	61	38	0.8	2
	HSK-E50 ER25.70	410082555025	ER 25	1 ~ 16	38	-	70	31	-	1	1

248

242-244

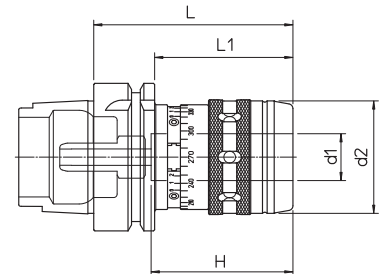
240

223



- HIGH PRECISION ULTRA-TIGHT BALANCEABLE TOOLHOLDER
- AUSWUCHTBARES PRÄZISIONSSPANNZANGENFUTTER MIT HOCHFESTER WERKZEUGSPANNUNG
- PORTAHERRAMIENTAS DE PRECISIÓN DE GRAN APRIETE EQUILIBRABLES
- PORTE-OUTIL ÉQUILIBRABLE DE PRÉCISION À SERRAGE FORT
- PORTAUTENSILE DI PRECISIONE A FORTE SERRAGGIO BILANCIABILE

## DIN 69893 HSK-A FORCE



187

- Supplied with coolant tube - without clamping wrench
- Lieferung inklusive Kühlmittelrohr. Ohne Spannzangen und Spannschlüssel
- Completo con racor para el refrigerante - Llave de apriete excluida
- Pourvu de raccord pour liquide d'arrosage - Sans clef de serrage
- Completo di raccordo per il refrigerante - Chiave di serraggio esclusa

HSK-A	REF.	CODE	d1	d2	H	L	L1	kg
63	<b>HSK-A63 FORCE20.85</b>	410002056320	20	48	60	85	59	1.2
	<b>HSK-A63 FORCE32.110</b>	410003256320	32	66	80	110	-	2

## KIT FORCE

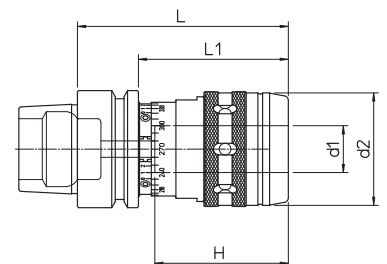


### K01 FORCE 20 K01 FORCE 32

1 FORCE 20	1 FORCE 32
1 RC 20.06	1 RC 32.06
1 RC 20.08	1 RC 32.08
1 RC 20.10	1 RC 32.10
1 RC 20.12	1 RC 32.12
1 RC 20.16	1 RC 32.16
1 CHV 50	1 RC 32.20
	1 RC 32.25
	1 CHV 75

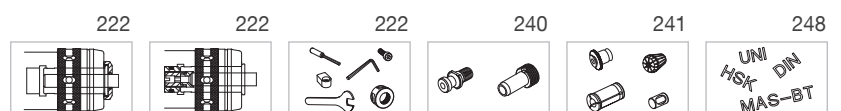
HSK-A	REF.	CODE
63	<b>KIT K01 FORCE 20 HSK63</b>	610002056320
	<b>KIT K01 FORCE 32 HSK63</b>	610003256320

## DIN 69893 HSK-E FORCE



- Without clamping wrench
- Ohne Spannschlüssel.
- Llave de apriete excluida
- Sans clef de serrage
- Chiave di serraggio esclusa

HSK-E	REF.	CODE	d1	d2	H	L	L1	kg
50	<b>HSK-E50 FORCE20.90</b>	410002055025	20	48	60	90	64	1.2



DIN 69871 A  
ER - DIN 6499

188

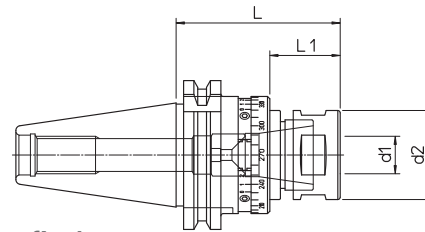


fig.1

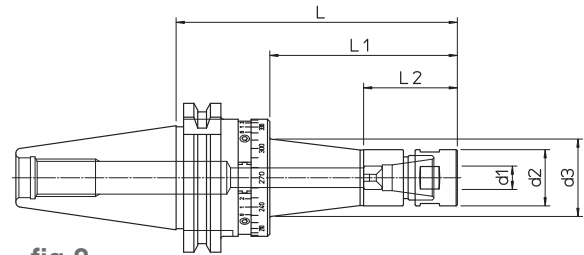


fig.2

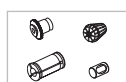
- Supplied without collets and clamping wrenches.  
The ring-nuts of the Toprun spindles allow the use of the ER collets with a working range of 0,5 mm.
- Ohne Spannzangen und Spanschlüssel.  
Die Spannmutter dieser Toprun-Aufnahmen sind für ER Spannzangen mit einem Arbeitsbereich von 0,5 mm vorgesehen.
- Pinzas elásticas y llaves de apriete excluidas.  
Las tuercas de los mandrinos Toprun permiten el empleo de las pinzas ER con un campo de trabajo de 0,5 mm.
- Sans pinces et clés de serrage.  
Les bagues des mandrins Toprun permettent l'usage des pinces ER avec une capacité d'usinage de 0,5 mm.
- Pinze elastiche e chiavi di serraggio escluse.  
Le ghiera dei mandrini Toprun permettono l'impiego delle pinze ER con un campo di lavoro di 0,5 mm.

DIN	REF.	CODE	TYPE	d <sub>1</sub>	d <sub>2</sub>	d <sub>3</sub>	L	L <sub>1</sub>	L <sub>2</sub>	kg	fig.
40	DIN69871-A40 ER16.70	410081614020	ER 16	0.5 ~ 10	24	-	70	30	-	1.1	1
	DIN69871-A40 ER16.120	410121614020				34	120	80	40	1.3	2
	DIN69871-A40 ER25.70	410082514020	ER 25	1 ~ 16	38	-	70	30	-	1.4	1
	DIN69871-A40 ER25.140	410122514020				45	140	100	50	1.8	2
	DIN69871-A40 ER32.75	410083214020	ER 32	2 ~ 20	50	-	75	-	-	1.7	1

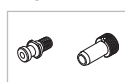
249



242-244



240

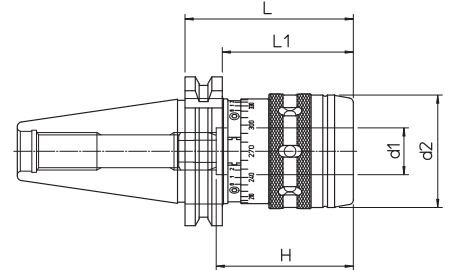


223



- HIGH PRECISION ULTRA-TIGHT BALANCEABLE TOOLHOLDER
- AUSWUCHTBARES PRÄZISIONSSPANNZANGENFUTTER MIT HOCHFESTER WERKZEUGSPANNUNG
- PORTAHERRAMIENTAS DE PRECISIÓN DE GRAN APRIETE EQUILIBRABLES
- PORTE-OUTIL ÉQUILIBRABLE DE PRÉCISION À SERRAGE FORT
- PORTAUTENSILE DI PRECISIONE A FORTE SERRAGGIO BILANCIABILE

DIN 69871 A  
FORCE



189

- Without clamping wrench
- Ohne Spannschlüssel
- Llave de apriete excluida
- Sans clef de serrage
- Chiave di serraggio esclusa

DIN	REF.	CODE	d1	d2	H	L	L1	kg
40	DIN69871-A40 FORCE20.75	410002014020	20	48	60	75	55.9	1.3
	DIN69871-A40 FORCE32.105	410003214020	32	66	80	105	-	2.1

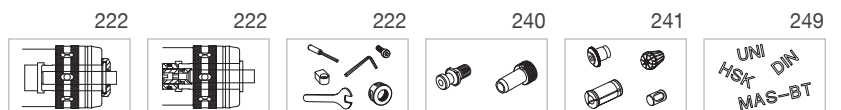
KIT FORCE



**K01 FORCE 20** **K01 FORCE 32**

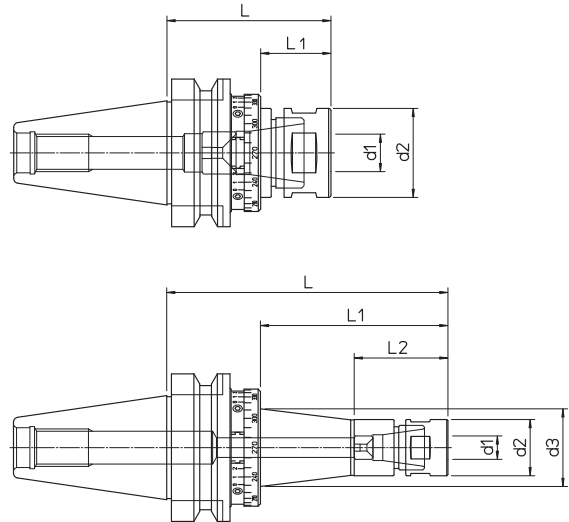
- |            |            |
|------------|------------|
| 1 FORCE 20 | 1 FORCE 32 |
| 1 RC 20.06 | 1 RC 32.06 |
| 1 RC 20.08 | 1 RC 32.08 |
| 1 RC 20.10 | 1 RC 32.10 |
| 1 RC 20.12 | 1 RC 32.12 |
| 1 RC 20.16 | 1 RC 32.16 |
| 1 CHV 50   | 1 RC 32.20 |
|            | 1 RC 32.25 |
|            | 1 CHV 75   |

DIN	REF.	CODE
40	KIT K01 FORCE20 DIN40	610002014020
	KIT K01 FORCE32 DIN40	610003214020



UNI  
HSK DIN  
MAS-BT

## MAS 403 BT ER-DIN 6499



- Supplied without collets and clamping wrenches.

The ring-nuts of the Toprun spindles allow the use of the ER collets with a working range of 0,5 mm.

- Ohne Spannzangen und Spanschlüssel.

Die Spannmutter dieser Toprun-Aufnahmen sind für ER Spannzangen mit einem Arbeitsbereich von 0,5 mm vorgesehen.

- Pinzas elásticas y llaves de apriete excluidas.

Las tuercas de los mandrinos Toprun permiten el empleo de las pinzas ER con un campo de trabajo de 0,5 mm.

- Sans pinces et clés de serrage.

Les bagues des mandrins Toprun permettent l'usage des pinces ER avec une capacité d'usinage de 0,5 mm.

- Pinze elastiche e chiavi di serraggio escluse.

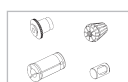
Le ghiere dei mandrini Toprun permettono l'impiego delle pinze ER con un campo di lavoro di 0,5 mm.

BT	REF.	CODE	TYPE	d <sub>1</sub>	d <sub>2</sub>	d <sub>3</sub>	L	L <sub>1</sub>	L <sub>2</sub>	kg	fig.
30	MAS403 BT30 ER16.60	410101613030	ER 16	0.5 ~ 10	24	-	60	25	-	0.8	1
	MAS403 BT30 ER16.90	410121613030				29	90	55	32	0.9	2
	MAS403 BT30 ER25.60	410102513030	ER 25	1 ~ 16	38	-	60	25.5	-	1.1	1
40	MAS403 BT40 ER16.70	410081614030	ER 16	0.5 ~ 10	24	-	70	30	-	1	
	MAS403 BT40 ER16.120	410121614030				34	120	80	40	1.3	2
	MAS403 BT40 ER25.70	410082514030	ER 25	1 ~ 16	38	-	70	30	-	1.4	1
	MAS403 BT40 ER25.140	410122514030				45	140	100	50	1.8	2
	MAS403 BT40 ER32.75	410083214030	ER 32	2 ~ 20	50	-	75	32	-	1.7	1

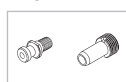
249



242-244



240

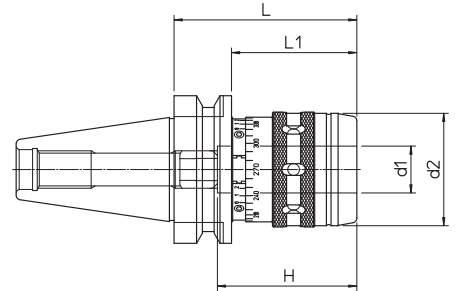


223



- HIGH PRECISION ULTRA-TIGHT BALANCEABLE TOOLHOLDER
- AUSWUCHTBARES PRÄZISIONSSPANNZANGENFUTTER MIT HOCHFESTER WERKZEUGSPANNUNG
- PORTAHERRAMIENTAS DE PRECISIÓN DE GRAN APRIETE EQUILIBRABLES
- PORTE-OUTIL ÉQUILIBRABLE DE PRÉCISION À SERRAGE FORT
- PORTAUTENSILE DI PRECISIONE A FORTE SERRAGGIO BILANCIABILE

MAS 403 BT  
FORCE



191

- Without clamping wrench
- Ohne Spannschlüssel
- Llave de apriete excluida
- Sans clef de serrage
- Chiave di serraggio esclusa

BT	REF.	CODE	d1	d2	H	L	L1	kg
40	MAS403 BT40 FORCE20.80	410002014030	20	48	60	80	53.5	1.4
	MAS403 BT40 FORCE32.90	410003214030	32	66	80	90	65	1.9

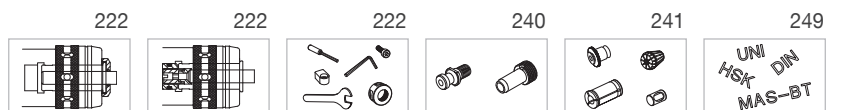
KIT FORCE



K01 FORCE 20 K01 FORCE 32

1 FORCE 20	1 FORCE 32
1 RC 20.06	1 RC 32.06
1 RC 20.08	1 RC 32.08
1 RC 20.10	1 RC 32.10
1 RC 20.12	1 RC 32.12
1 RC 20.16	1 RC 32.16
1 CHV 50	1 RC 32.20
	1 RC 32.25
	1 CHV 75

BT	REF.	CODE
40	KIT K01 FORCE20 BT40	610002014030
	KIT K01 FORCE32 BT40	610003214030





p. 240



p. 194

DIN 69893 HSK-A

ER  
WD  
PF  
CM  
MS

p. 240



p. 198

DIN 69871 AD+B

ER  
WD  
PF  
CM  
MS

p. 240

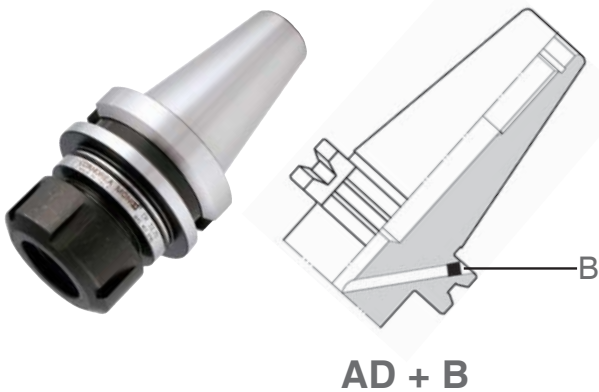


p. 204

MAS 403 BT AD+B

ER  
WD  
PF  
CM  
MS





*Quality, precision,  
strength and convenience*

- INTEGRATED TOOLHOLDERS
- INTEGRIERTEN WERKZEUGHALTER
- PORTAHERRAMIENTAS INTEGRALES
- PORTE-OUTILS INTÉGRAUX
- PORTAUTENSILI INTEGRALI

**GB** The integrated MONOd' tool holders represent an ideal solution to equip any type of machine tool with HSK 63 and 100, DIN AD+B and BT AD+B base arbors, guaranteeing the benefits of a high quality and high precision, with a price that is highly competitive on the market. The MONOd' program includes ER collet chucks, Weldon end mill holders, Morse tapers, and tapping chucks.

**All toolholders are designed to be balanced at G 6.3 8.000 RPM. MONOd' ER G 6,3 at 15.000 RPM.**

**D** Die vollständigen Werkzeughalter MONOd' stellen die ideale Lösung zum Ausstatten jeder Art von Werkzeugmaschine mit Basisanschluss HSK 63 und 100, DIN AD+B und BT AD+B dar und garantieren die Vorteile hoher Qualität und hohem Präzisionsgrad, zu einem sehr wettbewerbsfähigem Marktpreis. Das MONOd' Programm schließt ER Zangenhalterungen, Weldon, Fräsenhalterung, Reduktionen, Schraubstöße und Gewindebohrer ein.

**Alle Werkzeugaufnahmen sind ausgewuchtet von G 6,3 bei 8.000 U/min. MONOd' ER G 6,3 bei 15x.000 U/min.**

**E** Los portaherramientas integrales MONOd' representan la solución ideal para equipar cualquier tipo de máquina herramienta con unión base HSK 63 y 100, DIN AD+B y BT AD+B, garantizando las ventajas de elevada calidad y alto grado de precisión, con un precio de mercado altamente competitivo. El programa MONOd' incluye portapinzas ER, Weldon, Portafresas, Reducciones a Morse y Roscadores.

**Todos los portaherramientas son proyectados equilibrados G 6,3 con 8.000 giros por minuto. MONOd' ER G 6,3 con 15.000 giros por minuto.**

**F** Les porte-outils intégraux MONOd' représentent la solution idéale pour équiper tous les types de machine outils avec une fixation de base HSK 63 et 100, DIN AD+B et BT AD+B, en garantissant les avantages de la qualité élevée et du haut niveau de précision, à un prix de marché très compétitif. Le programme MONOd' comprend des porte-pincés ER, Weldon, des porte-fraises, des réductions des étaux et des taraudeurs.

**Tous les porte-outils sont équilibrés selon le projet G 6,3 à 8.000 tours/min. MONOd' ER G 6,3 à 15.000 tours/min.**

**I** I portautensili integrali MONOd' rappresentano la soluzione ideale per attrezzare ogni tipo di macchina utensile con attacco base HSK 63 e 100, DIN AD+B e BT AD+B, garantendo i vantaggi di elevata qualità e alto grado di precisione, con un prezzo di mercato altamente concorrenziale. Il programma MONOd' include portapinzas ER, Weldon, Portafrese, Riduzioni Morse e Maschiatori.

**Tutti i portautensili sono equilibrati di progetto, G 6,3 a 8.000 giri/min. MONOd' ER G 6,3 a 15.000 giri/min.**

## DIN 69893 HSK-A ER - DIN 6499

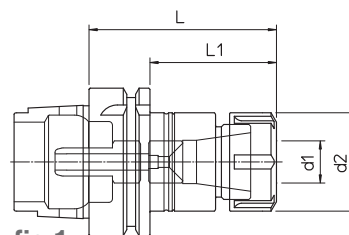


fig.1

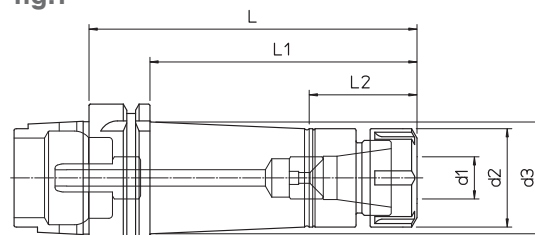


fig.2

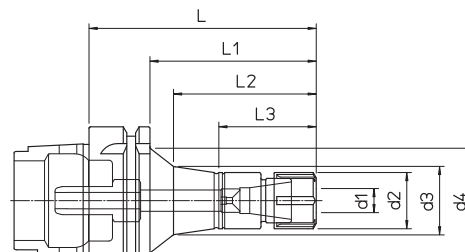


fig.3

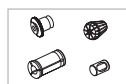
- Supplied with coolant tube - without collets and clamping wrenches
- Lieferung inklusive Kühlmittelrohr. Ohne Spannzangen und Spannschlüssel.
- Completo con racor para el refrigerante - Pinzas elásticas y llaves de apriete excluidas
- Pourvu de raccord pour liquide d'arrosage - Sans pinces et clés de serrage
- Completo di raccordo per il refrigerante - Pinze elastiche e chiavi di serraggio escluse

HSK-A	REF.	CODE	TYPE	d1	d2	d3	d4	L	L1	L2	L3	kg	fig.
63	HSK-A63 ER16.80	71HSKA063ER1608	ER 16 M	0.5 ~ 10	22	32		80	54	41		1.1	1
	HSK-A63 ER16.120	71HSKA063ER1612				31		120	94			1.9	2
	HSK-A63 ER25.80	71HSKA063ER2508	ER 25	1 ~ 16	42	-		80	54	-		1.3	1
	HSK-A63 ER25.140	71HSKA063ER2514				47.5		140	114	46		1.7	2
	HSK-A63 ER32.90	71HSKA063ER3209	ER 32	2 ~ 20	50	-		90	64	-		1.6	1
	HSK-A63 ER32.160	71HSKA063ER3216				160		134	-	2.2		2	
100	HSK-A100 ER16.100	71HSKA100ER1610	ER 16 M	0.5 ~ 10	22	25	45	100	71	61	41.5	2.3	3
	HSK-A100 ER16.160	71HSKA100ER1616				34.5	44	160	131	126		2.5	
	HSK-A100 ER25.100	71HSKA100ER2510	ER 25	1 ~ 16	42	45.5		100	71	47		2.6	
	HSK-A100 ER25.160	71HSKA100ER2516				49.5		160	131			3.2	
	HSK-A100 ER32.120	71HSKA100ER3212	ER 32	2 ~ 20	50	55		120	91	52		3.1	2
	HSK-A100 ER32.160	71HSKA100ER3216				56.5		160	131			3.7	
	HSK-A100 ER40.120	71HSKA100ER4012	ER 40	3 ~ 26	63	71.5		120	91	60		3.5	

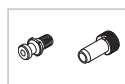
248



242-244



240



223



- WELDON TOOLHOLDER
- WERKZEUGAUFNAHME FÜR WELDON
- PORTAHERRAMIENTA WELDON
- PORTE-OUTIL WELDON
- PORTAUTENSILE WELDON

DIN 69893 HSK-A  
WD - DIN 1835-B

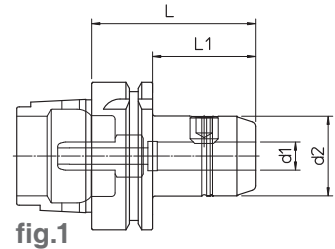


fig.1

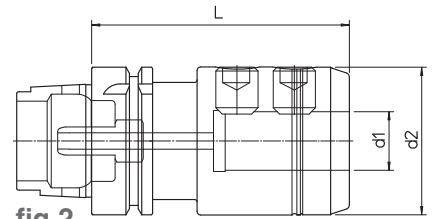


fig.2

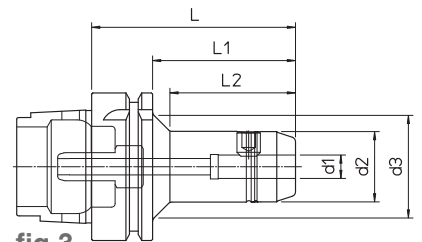


fig.3

- Supplied with coolant tube
- Lieferung inklusive Kühlmittelrohr
- Completo con racor para el refrigerante
- Pourvu de raccord pour liquide d'arrosage
- Completo di raccordo per il refrigerante

HSK-A	REF.	CODE	d <sub>1</sub> <sup>H5</sup>	d <sub>2</sub>	d <sub>3</sub>	L	L <sub>1</sub>	L <sub>2</sub>	kg	fig.
63	HSK-A63 WD06.60	71HСКА063WD0606	6	23	-	60	34	-	0.8	1
	HSK-A63 WD08.65	71HСКА063WD0806	8	26		65	39		0.9	
	HSK-A63 WD10.70	71HСКА063WD1007	10	30		70	44		1.1	
	HSK-A63 WD12.70	71HСКА063WD1207	12	34		80	54		1.2	
	HSK-A63 WD16.80	71HСКА063WD1608	16	42		110	-		1.4	
	HSK-A63 WD20.80	71HСКА063WD2008	20	50		110	-		1.5	
	HSK-A63 WD25.110	71HСКА063WD2511	25	63		110	-		2.3	
	HSK-A63 WD32.110	71HСКА063WD3211	32	70		110	-		2.5	
100	HSK-A100 WD10.90	71HСКА100WD1009	10	30	45	90	61	53.5	2.3	3
	HSK-A100 WD12.100	71HСКА100WD1210	12	34		100	71	65.5	2.4	
	HSK-A100 WD14.100	71HСКА100WD1410	14	38		100	71	67.5	2.5	
	HSK-A100 WD16.100	71HСКА100WD1610	16	42	-	110	81	-	2.6	1
	HSK-A100 WD18.110	71HСКА100WD1811	18	46					3	
	HSK-A100 WD20.110	71HСКА100WD2011	20	50					3.1	
	HSK-A100 WD25.120	71HСКА100WD2512	25	63					3.9	
	HSK-A100 WD32.120	71HСКА100WD3212	32	70					4.3	
	HSK-A100 WD40.120	71HСКА100WD4012	40	80					4.8	

## DIN 69893 HSK-A PF

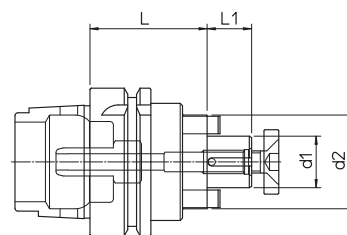


fig.1

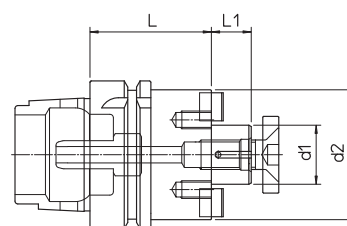


fig.2

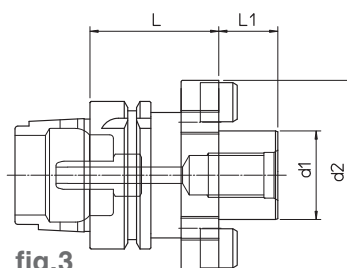
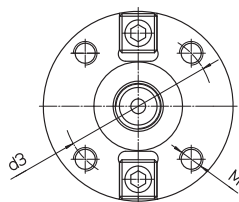
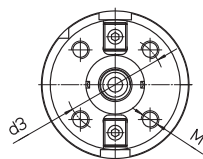


fig.3



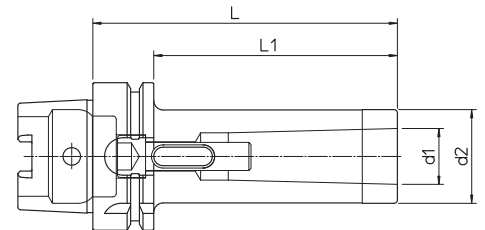
- Supplied with coolant tube
- Lieferung inklusive Kühlmittelrohr
- Completo con racor para el refrigerante
- Pourvu de raccord pour liquide d'arrosage
- Completo di raccordo per il refrigerante

HSK-A	REF.	CODE	d <sub>1</sub>	d <sub>2</sub>	d <sub>3</sub>	M	L	L <sub>1</sub>	kg	fig.
63	HSK-A63 PF16.50	71HSKA063PF1605	16	32			50	17	1.1	1
	HSK-A63 PF22.50	71HSKA063PF2205	22	40	-			19	1.2	
	HSK-A63 PF27.55	71HSKA063PF2705	27	50				21	1.4	
	HSK-A63 PF32.60	71HSKA063PF3206	32	60				24	1.8	
100	HSK-A100 PF22.65	71HSKA100PF2265	22	40			65	19	2.3	2
	HSK-A100 PF27.65	71HSKA100PF2765	27	50	-			21	2.5	
	HSK-A100 PF32.70	71HSKA100PF3270	32	60			70	24	2.9	
	HSK-A100 PF40.70	71HSKA100PF4070	40	88	66.7	M12		27	3.3	
	HSK-A100 PF60.75	71HSKA100PF6075	60	128.5	101.6	M16		75	4.2	



- MORSE TAPER TOOLHOLDER
- WERKZEUGAUFNAHME FÜR MORSEKEGEL
- PORTAHERRAMIENTA CONO MORSE
- PORTE-OUTIL CONE MORSE
- PORTAUTENSILE CONO MORSE

DIN 69893 HSK-A  
CM - DIN 228 AB

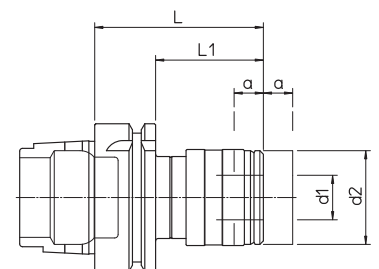


197

HSK-A	REF.	CODE	MORSE	d <sub>1</sub>	d <sub>2</sub>	L	L <sub>1</sub>	kg
63	HSK-A63 CM2.110 A-B	71HСКА063CMB211	2	17.780	32	110	84	2
	HSK-A63 CM3.130 A-B	71HСКА063CMB313	3	23.825	40	130	104	2.2
	HSK-A63 CM4.155 A-B	71HСКА063CMB415	4	31.267	48	155	129	2.6

- TAPPING TOOLHOLDER
- AUFNAHME MIT GEWINDESCHNEIDSCHNELLWECHSELFUTTER
- PORTAHERRAMIENTA PARA ROSCAR
- PORTE-OUTIL DE TARAUDAGE
- PORTAUTENSILE MASCHIATORE

DIN 69893 HSK-A  
MS



HSK-A	REF.	CODE	d <sub>1</sub>	d <sub>2</sub>	L	L <sub>1</sub>	a	kg
63	HSK-A63 MS1 M3-12	71HСКА063M10312	19	39	72	46	7.5	1
	HSK-A63 MS2 M8-20	71HСКА063M20820	31	60	110	84	10	1.7





DIN 69871 AD+B40

ER - DIN 6499

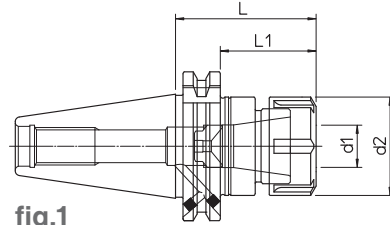


fig.1

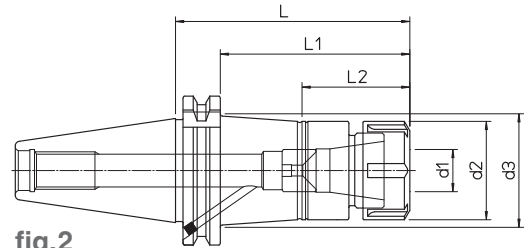


fig.2

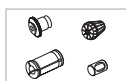
- Supplied without collets and clamping wrenches
- Ohne Spannzangen und Spannschlüssel.
- Pinzas elásticas y llaves de apriete excluidas
- Sans pinces et clés de serrage
- Pinze elastiche e chiavi di serraggio escluse

DIN	REF.	CODE	TYPE	d1	d2	d3	L	L1	L2	kg	fig.
40	DIN69871-AD+B40 ER16.60	71DIN-B40ER1606	ER 16 M	0.5 ~ 10	22	-	60	41	-	0.9	1
	DIN69871-AD+B40 ER16.100	71DIN-B40ER1610				29.5	100	81	41	1	2
	DIN69871-AD+B40 ER16.160	71DIN-B40ER1616				38	160	141	41	2	2
	DIN69871-AD+B40 ER25.60	71DIN-B40ER2506	ER 25	1 ~ 16	42	-	60	41	-	1.1	1
	DIN69871-AD+B40 ER25.100	71DIN-B40ER2510				47	100	81	46	1.6	2
	DIN69871-AD+B40 ER25.160	71DIN-B40ER2516				50	160	141	46	2.1	2
	DIN69871-AD+B40 ER32.70	71DIN-B40ER3207	ER 32	2 ~ 20	50	-	70	51	-	1.2	1
	DIN69871-AD+B40 ER32.110	71DIN-B40ER3211					110	91		1.7	
	DIN69871-AD+B40 ER32.160	71DIN-B40ER3216					160	141		2.7	
	DIN69871-AD+B40 ER40.80	71DIN-B40ER4008	ER 40	3 ~ 26	63	-	80	61	-	1.3	
	DIN69871-AD+B40 ER40.120	71DIN-B40ER4012					120	101	2.3		
	DIN69871-AD+B40 ER40.160	71DIN-B40ER4016					160	141	3.3		

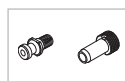
249



242-244



240



223



- COLLET CHUCK HOLDER
- SPANNZANGENFUTTER
- PORTAPINZAS
- PORTE-PINCES
- PORTAPINZE

## DIN 69871 AD+B50

ER - DIN 6499

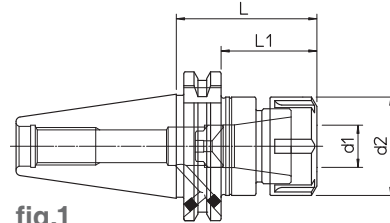


fig.1

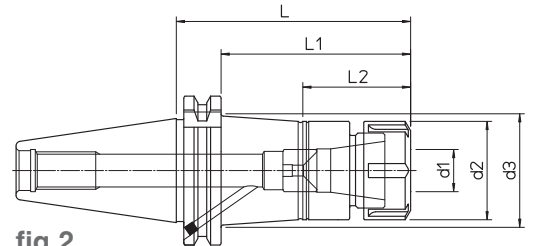


fig.2

199

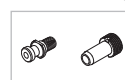
- Supplied without collets and clamping wrenches
- Ohne Spannzangen und Spannschlüssel.
- Pinzas elásticas y llaves de apriete excluidas
- Sans pinces et clés de serrage
- Pinze elastiche e chiavi di serraggio escluse

DIN	REF.	CODE	TYPE	d <sub>1</sub>	d <sub>2</sub>	d <sub>3</sub>	L	L <sub>1</sub>	L <sub>2</sub>	kg	fig.
50	DIN69871-AD+B50 ER16.100	71DIN-B50ER1610	ER 16 M	0.5 ~ 10	22	29.5	100	81	41	2.5	2
	DIN69871-AD+B50 ER16.160	71DIN-B50ER1616				32.5	160	141		3.3	
	DIN69871-AD+B50 ER25.70	71DIN-B50ER2507	ER 25	1 ~ 16	42	-	70	51	-	2.5	1
	DIN69871-AD+B50 ER25.110	71DIN-B50ER2511				48	110	91	46	2.8	2
	DIN69871-AD+B50 ER25.160	71DIN-B50ER2516	50	160	141	3.6					
	DIN69871-AD+B50 ER32.70	71DIN-B50ER3207	ER 32	2 ~ 20	50	-	70	51	-	2.9	1
	DIN69871-AD+B50 ER32.110	71DIN-B50ER3211				55	110	91	52	3.4	2
	DIN69871-AD+B50 ER32.160	71DIN-B50ER3216	57.5	160	141	4					
	DIN69871-AD+B50 ER40.100	71DIN-B50ER4010	ER 40	3 ~ 26	63	65	100	81	55	3.8	
	DIN69871-AD+B50 ER40.160	71DIN-B50ER4016				70	160	141		4.3	

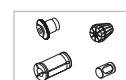
223



240



242-244



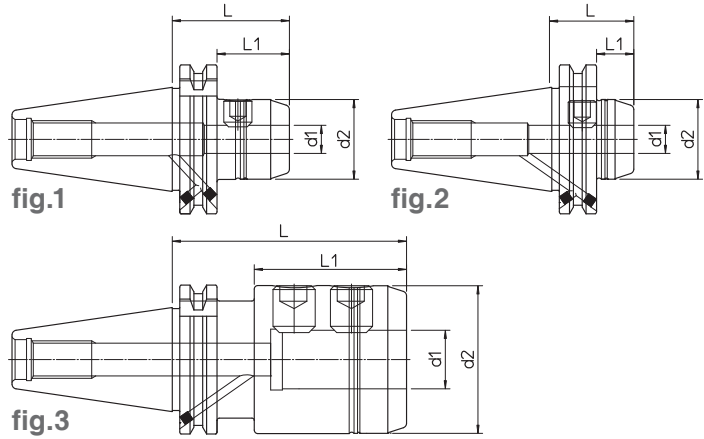
249



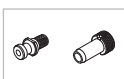
- WELDON TOOLHOLDER
- WERKZEUGAUFNAHME FÜR WELDON
- PORTAHERRAMIENTA WELDON
- PORTE-OUTIL WELDON
- PORTAUTENSILE WELDON

DIN 69871 AD+B40

WD - DIN 1835-B

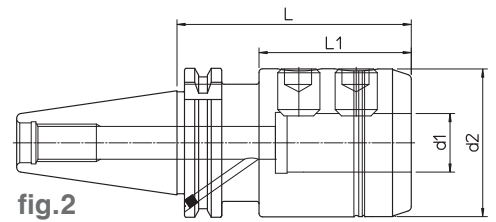
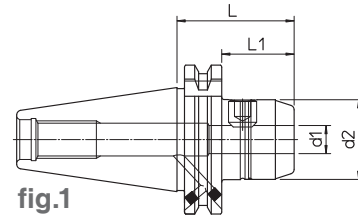


DIN	REF.	CODE	d <sub>1</sub> <sup>H5</sup>	d <sub>2</sub>	L	L <sub>1</sub>	kg	fig.	
40	DIN69871-AD+B40 WD06.50	71DIN-B40WD0605	6	23	50	31	0.8	1	
	DIN69871-AD+B40 WD06.110	71DIN-B40WD0611			110	91	1		
	DIN69871-AD+B40 WD06.160	71DIN-B40WD0616			160	141	1.1		
	DIN69871-AD+B40 WD08.50	71DIN-B40WD0805	8	26	50	31	0.9		
	DIN69871-AD+B40 WD08.110	71DIN-B40WD0811			110	91	1.1		
	DIN69871-AD+B40 WD08.160	71DIN-B40WD0816			160	141	1.3		
	DIN69871-AD+B40 WD10.50	71DIN-B40WD1005	10	30	50	31	1		
	DIN69871-AD+B40 WD10.110	71DIN-B40WD1011			110	91	1.4		
	DIN69871-AD+B40 WD10.160	71DIN-B40WD1016			160	141	1.6		
	DIN69871-AD+B40 WD12.35	71DIN-B40WD1203	12	34	35	16	1	2	
	DIN69871-AD+B40 WD12.50	71DIN-B40WD1205			50	31	1.1	1	
	DIN69871-AD+B40 WD12.110	71DIN-B40WD1211			110	91	1.4		
	DIN69871-AD+B40 WD12.160	71DIN-B40WD1216			160	141	1.7		
	DIN69871-AD+B40 WD14.50	71DIN-B40WD1405	14	38	50	31	1.2	1	
	DIN69871-AD+B40 WD14.110	71DIN-B40WD1411			110	91	1.6		
	DIN69871-AD+B40 WD16.35	71DIN-B40WD1603	16	42	35	16	1.1	2	
	DIN69871-AD+B40 WD16.63	71DIN-B40WD1606			63	44	1.3	1	
	DIN69871-AD+B40 WD16.110	71DIN-B40WD1611			110	91	1.7		
	DIN69871-AD+B40 WD16.160	71DIN-B40WD1616			160	141	2.2		
	DIN69871-AD+B40 WD18.63	71DIN-B40WD1806	18	46	63	44	1.4	1	
	DIN69871-AD+B40 WD18.110	71DIN-B40WD1811			110	91	1.9		
	DIN69871-AD+B40 WD20.35	71DIN-B40WD2003	20	44	35	16	1.2	2	
	DIN69871-AD+B40 WD20.63	71DIN-B40WD2006			50	63	44	1.5	1
	DIN69871-AD+B40 WD20.110	71DIN-B40WD2011				110	91	2.1	
DIN69871-AD+B40 WD20.160	71DIN-B40WD2016	160				141	2.6		
DIN69871-AD+B40 WD25.35	71DIN-B40WD2503	25	44	35	16	1.3	2		
DIN69871-AD+B40 WD25.100	71DIN-B40WD2510			63	100	65	2	3	
DIN69871-AD+B40 WD25.160	71DIN-B40WD2516				160	125	3.2		
DIN69871-AD+B40 WD32.100	71DIN-B40WD3210	32	70	100	65	2.5	3		
DIN69871-AD+B40 WD32.160	71DIN-B40WD3216			160	125	3.9			



- WELDON TOOLHOLDER
- WERKZEUGAUFNAHME FÜR WELDON
- PORTAHERRAMIENTA WELDON
- PORTE-OUTIL WELDON
- PORTAUTENSILE WELDON

DIN 69871 AD+B50  
WD - DIN 1835-B



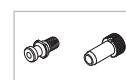
201

DIN	REF.	CODE	d <sub>1</sub> <sup>H5</sup>	d <sub>2</sub>	L	L <sub>1</sub>	kg	fig.
50	DIN69871-AD+B50 WD06.63	71DIN-B50WD0606	6	23	63	44	2.3	1
	DIN69871-AD+B50 WD06.110	71DIN-B50WD0611			110	91	2.4	
	DIN69871-AD+B50 WD06.160	71DIN-B50WD0616			160	141	2.5	
	DIN69871-AD+B50 WD08.63	71DIN-B50WD0806	8	26	63	44	2.4	
	DIN69871-AD+B50 WD08.110	71DIN-B50WD0811			110	91	2.5	
	DIN69871-AD+B50 WD08.160	71DIN-B50WD0816			160	141	2.7	
	DIN69871-AD+B50 WD10.63	71DIN-B50WD1006	10	30	63	44	2.5	
	DIN69871-AD+B50 WD10.110	71DIN-B50WD1011			110	91	2.7	
	DIN69871-AD+B50 WD10.160	71DIN-B50WD1016			160	141	2.9	
	DIN69871-AD+B50 WD12.63	71DIN-B50WD1206	12	34	63	44	2.6	
	DIN69871-AD+B50 WD12.110	71DIN-B50WD1211			110	91	2.8	
	DIN69871-AD+B50 WD12.160	71DIN-B50WD1216			160	141	3.2	
	DIN69871-AD+B50 WD14.63	71DIN-B50WD1406	14	38	63	44	2.7	
	DIN69871-AD+B50 WD14.110	71DIN-B50WD1411			110	91	3	
	DIN69871-AD+B50 WD16.63	71DIN-B50WD1606	16	42	63	44	2.8	
	DIN69871-AD+B50 WD16.110	71DIN-B50WD1611			110	91	3.2	
	DIN69871-AD+B50 WD16.160	71DIN-B50WD1616			160	141	3.7	
	DIN69871-AD+B50 WD18.63	71DIN-B50WD1806	18	46	63	44	2.9	
	DIN69871-AD+B50 WD18.110	71DIN-B50WD1811			110	91	3.4	
	DIN69871-AD+B50 WD20.63	71DIN-B50WD2006	20	50	63	44	3	
	DIN69871-AD+B50 WD20.110	71DIN-B50WD2011			110	91	3.6	
	DIN69871-AD+B50 WD20.160	71DIN-B50WD2016			160	141	4.2	
	DIN69871-AD+B50 WD25.80	71DIN-B50WD2508	25	63	80	61	3.5	
	DIN69871-AD+B50 WD25.110	71DIN-B50WD2511			110	91	4.1	
DIN69871-AD+B50 WD25.160	71DIN-B50WD2516	160			141	5.1		
DIN69871-AD+B50 WD32.100	71DIN-B50WD3210	32	70	100	81	4.6		
DIN69871-AD+B50 WD32.160	71DIN-B50WD3216			160	141	6		
DIN69871-AD+B50 WD40.100	71DIN-B50WD4010	40	80	100	81	4.8		
DIN69871-AD+B50 WD40.160	71DIN-B50WD4016			160	141	6.5		

223

240

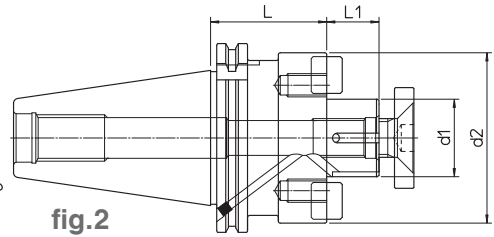
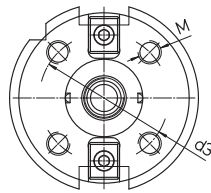
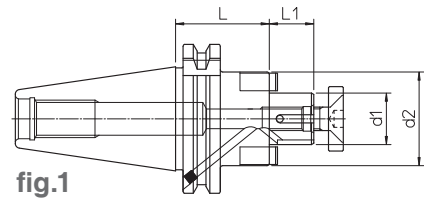
249



- MILL HOLDER
- WERKZEUGAUFNAHME FÜR AUFSTECKFRÄSER
- PORTAFRESA
- PORTE-FRAISES
- PORTAFRESA

## DIN 69871 AD+B

PF

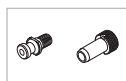


DIN	REF.	CODE	d <sub>1</sub>	d <sub>2</sub>	d <sub>3</sub>	M	L	L <sub>1</sub>	kg	fig.		
40	DIN69871-AD+B40 PF16.35	71DIN-B40PF1603	16	32	-	-	35		0.9	1		
	DIN69871-AD+B40 PF16.110	71DIN-B40PF1611					110		17		1.3	
	DIN69871-AD+B40 PF16.160	71DIN-B40PF1616					160				1.9	
	DIN69871-AD+B40 PF22.40	71DIN-B40PF2204	22	40			40	19	1			
	DIN69871-AD+B40 PF22.110	71DIN-B40PF2211					110		1.7			
	DIN69871-AD+B40 PF22.160	71DIN-B40PF2216					160		2.1			
	DIN69871-AD+B40 PF27.45	71DIN-B40PF2704	27	50			45	21	1.2			
	DIN69871-AD+B40 PF27.110	71DIN-B40PF2711					110		2.2			
	DIN69871-AD+B40 PF27.160	71DIN-B40PF2716					160		2.9			
	DIN69871-AD+B40 PF32.50	71DIN-B40PF3205	32	60			50	24	1.7			
	DIN69871-AD+B40 PF32.110	71DIN-B40PF3211					110		3			
DIN69871-AD+B40 PF40.55	71DIN-B40PF4005	40	70	55	27	2.1						
50	DIN69871-AD+B50 PF16.40	71DIN-B50PF1604	16	32	-	-	40	17	2.4	2		
	DIN69871-AD+B50 PF16.110	71DIN-B50PF1611					110		2.8			
	DIN69871-AD+B50 PF16.160	71DIN-B50PF1616					160		3.1			
	DIN69871-AD+B50 PF22.45	71DIN-B50PF2204	22	40			45	19	2.6			
	DIN69871-AD+B50 PF22.110	71DIN-B50PF2211					110		3.2			
	DIN69871-AD+B50 PF22.160	71DIN-B50PF2216					160		3.7			
	DIN69871-AD+B50 PF27.50	71DIN-B50PF2705	27	50			50	21	2.7			
	DIN69871-AD+B50 PF27.110	71DIN-B50PF2711					110		3.6			
	DIN69871-AD+B50 PF27.160	71DIN-B50PF2716					160		4.4			
	DIN69871-AD+B50 PF32.55	71DIN-B50PF3205	32	60			55	24	3.2			
	DIN69871-AD+B50 PF32.120	71DIN-B50PF3212					120		5.5			
	DIN69871-AD+B50 PF40.60	71DIN-B50PF4006	40	88			66.7	M12	60		27	4.3
	DIN69871-AD+B50 PF40.120	71DIN-B50PF4012							120			7.1
DIN69871-AD+B50 PF60.70	71DIN-B50PF6007	60	128.5	101.6	M16	70	40	6.6				

249

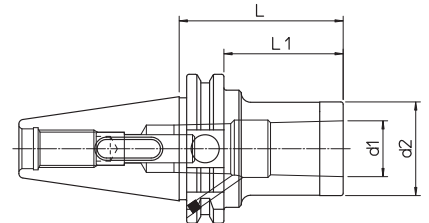
240

223



- MORSE TAPER TOOLHOLDER
- WERKZEUGAUFNAHME FÜR MORSEKEGEL
- PORTAHERRAMIENTA CONO MORSE
- PORTE-OUTIL CONE MORSE
- PORTAUTENSILE CONO MORSE

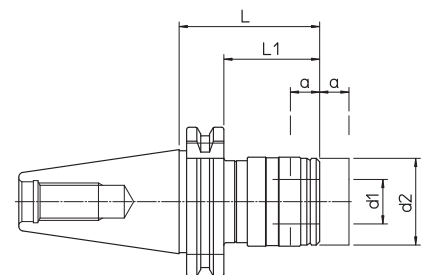
DIN 69871 AD+B  
CM - DIN 228 AB



DIN	REF.	CODE	MORSE	d <sub>1</sub>	d <sub>2</sub>	L	L <sub>1</sub>	kg
40	DIN69871-AD+B40 CM2.50 A-B	71DIN-B40CMB205	2	17.780	32	50	31	1
	DIN69871-AD+B40 CM2.125 A-B	71DIN-B40CMB212				125	106	1.4
	DIN69871-AD+B40 CM3.70 A-B	71DIN-B40CMB307	3	23.825	40	51	1.1	
	DIN69871-AD+B40 CM3.140 A-B	71DIN-B40CMB314			42	121	1.5	
50	DIN69871-AD+B50 CM2.60 A-B	71DIN-B50CMB206	2	17.780	32	60	41	2.6
	DIN69871-AD+B50 CM2.125 A-B	71DIN-B50CMB212				125	106	2.8
	DIN69871-AD+B50 CM3.60 A-B	71DIN-B50CMB306	3	23.825	40	41	2.7	
	DIN69871-AD+B50 CM3.140 A-B	71DIN-B50CMB314			42	121	3.2	
	DIN69871-AD+B50 CM4.80 A-B	71DIN-B50CMB408	4	31.267	48	80	61	2.9

- TAPPING TOOLHOLDER
- AUFNAHME MIT GEWINDESCHNEIDSCHNELLWECHSELFUTTER
- PORTAHERRAMIENTA PARA ROSCAR
- PORTE-OUTIL DE TARAUDAGE
- PORTAUTENSILE MASCHIATORE

DIN 69871 A  
MS



DIN	REF.	CODE	d <sub>1</sub>	d <sub>2</sub>	L	L <sub>1</sub>	a	kg
40	DIN69871-A40 MS1 M3-12	71DIN-A40M10312	19	36	60	40.9	7.5	0.9
	DIN69871-A40 MS2 M8-20	71DIN-A40M20820	31	53	98	78.9	12.5	1.3
50	DIN69871-A50 MS1 M3-12	71DIN-A50M10312	19	38	62	42.9	7.5	2.8
	DIN69871-A50 MS2 M8-20	71DIN-A50M20820	31	53	84	64.9	12.5	3.1
	DIN69871-A50 MS3 M14-33	71DIN-A50M31433	48	78	139	119.9	20	4.3





## MAS 403 BT40 AD+B ER - DIN 6499

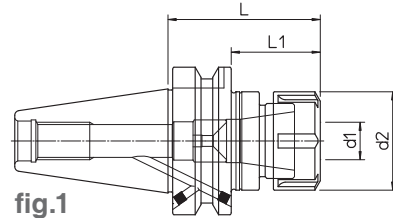


fig.1

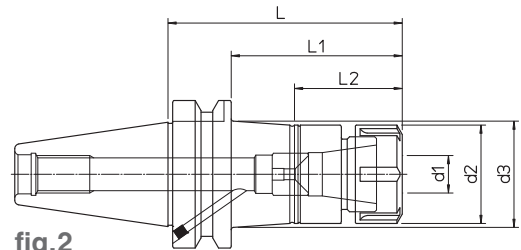
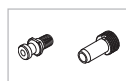
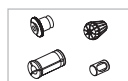


fig.2

- Supplied without collets and clamping wrenches
- Ohne Spannzangen und Spannschlüssel.
- Pinzas elásticas y llaves de apriete excluidas
- Sans pinces et clés de serrage
- Pinze elastiche e chiavi di serraggio escluse

BT	REF.	CODE	TYPE	d1	d2	d3	L	L1	L2	kg	fig.
40	MAS403 BT40-AD+B ER16.60	71MBT-B40ER1606	ER 16 M	0.5 ~ 10	22	-	60	33	-	1	1
	MAS403 BT40-AD+B ER16.100	71MBT-B40ER1610				28	100	73	41	1.1	2
	MAS403 BT40-AD+B ER16.160	71MBT-B40ER1616				36.5	160	133		2.1	
	MAS403 BT40-AD+B ER25.65	71MBT-B40ER2506	ER 25	1 ~ 16	42	-	65	38	-	1.2	1
	MAS403 BT40-AD+B ER25.100	71MBT-B40ER2510				45.5	100	73	46	1.7	2
	MAS403 BT40-AD+B ER25.160	71MBT-B40ER2516				49.5	160	133		2.2	
	MAS403 BT40-AD+B ER32.70	71MBT-B40ER3207	ER 32	2 ~ 20	50	-	70	43	-	1.3	1
	MAS403 BT40-AD+B ER32.110	71MBT-B40ER3211					110	83		1.8	
	MAS403 BT40-AD+B ER32.160	71MBT-B40ER3216					160	133		2.8	
	MAS403 BT40-AD+B ER40.80	71MBT-B40ER4008	ER 40	3 ~ 26	63	-	80	53	-	1.4	1
	MAS403 BT40-AD+B ER40.120	71MBT-B40ER4012					120	93		2.4	
	MAS403 BT40-AD+B ER40.160	71MBT-B40ER4016					160	133		3.4	



- COLLET CHUCK HOLDER
- SPANNZANGENFUTTER
- PORTAPINZAS
- PORTE-PINCES
- PORTAPINZE

MAS 403 BT50 AD+B  
ER - DIN 6499

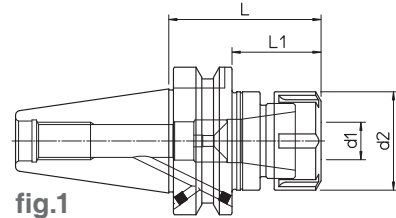


fig.1

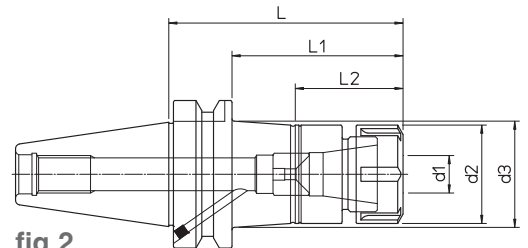


fig.2

205

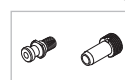
- Supplied without collets and clamping wrenches
- Ohne Spannzangen und Spannschlüssel.
- Pinzas elásticas y llaves de apriete excluidas
- Sans pinces et clés de serrage
- Pinze elastiche e chiavi di serraggio escluse

BT	REF.	CODE	TYPE	d <sub>1</sub>	d <sub>2</sub>	d <sub>3</sub>	L	L <sub>1</sub>	L <sub>2</sub>	kg	fig.
50	MAS403 BT50-AD+B ER16.100	71MBT-B50ER1610	ER 16 M	0.5 ~ 10	22	26.5	100	62	41	3.6	2
	MAS403 BT50-AD+B ER16.160	71MBT-B50ER1616				31	160	122		4.3	
	MAS403 BT50-AD+B ER25.75	71MBT-B50ER2507	ER 25	1 ~ 16	42	-	75	37	-	3.5	1
	MAS403 BT50-AD+B ER25.110	71MBT-B50ER2511				45.5	110	72	46	3.8	2
	MAS403 BT50-AD+B ER25.160	71MBT-B50ER2516	48.5	160	122	4.6					
	MAS403 BT50-AD+B ER32.80	71MBT-B50ER3208	ER 32	2 ~ 20	50	-	80	42	-	3.9	1
	MAS403 BT50-AD+B ER32.110	71MBT-B50ER3211				52.5	110	72	52	4.4	2
	MAS403 BT50-AD+B ER32.160	71MBT-B50ER3216	56	160	122	5					
	MAS403 BT50-AD+B ER40.100	71MBT-B50ER4010	ER 40	3 ~ 26	63	-	100	62	-	4.8	1
	MAS403 BT50-AD+B ER40.160	71MBT-B50ER4016				68.5	160	122	55	5.3	2

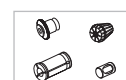
223



240



242-244

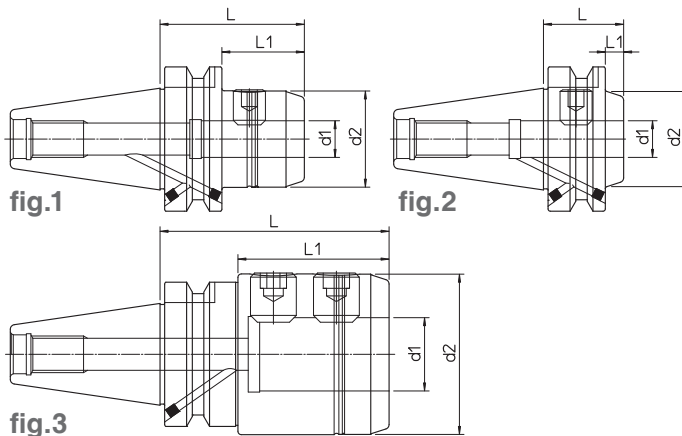


249

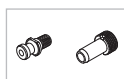


- WELDON TOOLHOLDER
- WERKZEUGAUFNAHME FÜR WELDON
- PORTAHERRAMIENTA WELDON
- PORTE-OUTIL WELDON
- PORTAUTENSILE WELDON

## MAS 403 BT40 AD+B WD - DIN 1835-B

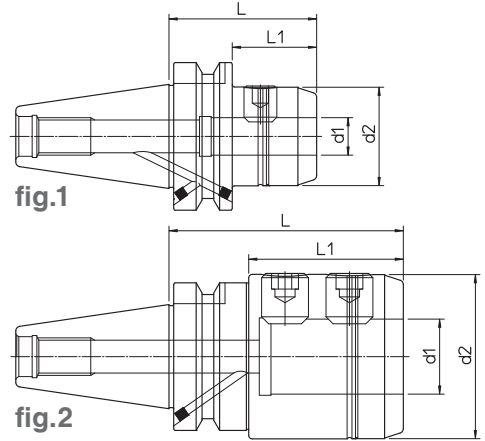


BT	REF.	CODE	d1 <sup>H5</sup>	d2	L	L1	kg	fig.
40	MAS403 BT40-AD+B WD06.50	71MBT-B40WD0605	6	23	50	23	0.8	1
	MAS403 BT40-AD+B WD06.110	71MBT-B40WD0611			110	83	0.9	
	MAS403 BT40-AD+B WD06.160	71MBT-B40WD0616			160	133	1.1	
	MAS403 BT40-AD+B WD08.50	71MBT-B40WD0805	8	26	50	23	0.9	
	MAS403 BT40-AD+B WD08.110	71MBT-B40WD0811			110	83	1.1	
	MAS403 BT40-AD+B WD08.160	71MBT-B40WD0816			160	133	1.3	
	MAS403 BT40-AD+B WD10.56	71MBT-B40WD1005	10	30	56	29	1	
	MAS403 BT40-AD+B WD10.110	71MBT-B40WD1011			110	83	1.2	
	MAS403 BT40-AD+B WD10.160	71MBT-B40WD1016			160	133	1.5	
	MAS403 BT40-AD+B WD12.35	71MBT-B40WD1203	12	34	35	8	0.9	2
	MAS403 BT40-AD+B WD12.56	71MBT-B40WD1205			56	29	1.1	1
	MAS403 BT40-AD+B WD12.110	71MBT-B40WD1211			110	83	1.4	
	MAS403 BT40-AD+B WD12.160	71MBT-B40WD1216			160	133	1.7	
	MAS403 BT40-AD+B WD14.56	71MBT-B40WD1405	14	38	56	29	1.2	
	MAS403 BT40-AD+B WD14.110	71MBT-B40WD1411			110	83	1.6	
	MAS403 BT40-AD+B WD16.35	71MBT-B40WD1603	16	42	35	8	1	2
	MAS403 BT40-AD+B WD16.63	71MBT-B40WD1606			63	36	1.3	1
	MAS403 BT40-AD+B WD16.110	71MBT-B40WD1611			110	83	1.7	
	MAS403 BT40-AD+B WD16.160	71MBT-B40WD1616			160	133	2.2	
	MAS403 BT40-AD+B WD18.63	71MBT-B40WD1806	18	46	63	36	1.4	
	MAS403 BT40-AD+B WD18.110	71MBT-B40WD1811			110	83	1.9	
	MAS403 BT40-AD+B WD20.35	71MBT-B40WD2003	20	50	35	8	1.1	2
	MAS403 BT40-AD+B WD20.63	71MBT-B40WD2006			63	36	1.5	1
	MAS403 BT40-AD+B WD20.110	71MBT-B40WD2011			110	83	2.1	
	MAS403 BT40-AD+B WD20.160	71MBT-B40WD2016			160	133	2.6	
	MAS403 BT40-AD+B WD25.35	71MBT-B40WD2503	25	63	35	8	1	2
	MAS403 BT40-AD+B WD25.100	71MBT-B40WD2510			100	73	2	3
	MAS403 BT40-AD+B WD25.160	71MBT-B40WD2516			160	133	3.2	
MAS403 BT40-AD+B WD32.100	71MBT-B40WD3210	32	70	100	67	2.5		
MAS403 BT40-AD+B WD32.160	71MBT-B40WD3216			160	127	3.9		



- WELDON TOOLHOLDER
- WERKZEUGAUFNAHME FÜR WELDON
- PORTAHERRAMIENTA WELDON
- PORTE-OUTIL WELDON
- PORTAUTENSILE WELDON

MAS 403 BT50 AD+B  
WD - DIN 1835-B



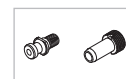
207

BT	REF.	CODE	d1 <sup>H5</sup>	d2	L	L1	kg	fig.
50	MAS403 BT50-AD+B WD06.63	71MBT-B50WD0606	6	23	63	25	2.3	1
	MAS403 BT50-AD+B WD06.110	71MBT-B50WD0611			110	72	2.4	
	MAS403 BT50-AD+B WD06.160	71MBT-B50WD0616			160	122	2.6	
	MAS403 BT50-AD+B WD08.63	71MBT-B50WD0806	8	26	63	25	2.4	
	MAS403 BT50-AD+B WD08.110	71MBT-B50WD0811			110	72	2.5	
	MAS403 BT50-AD+B WD08.160	71MBT-B50WD0816			160	122	2.7	
	MAS403 BT50-AD+B WD10.70	71MBT-B50WD1007	10	30	70	32	3	
	MAS403 BT50-AD+B WD10.110	71MBT-B50WD1011			110	72	3.2	
	MAS403 BT50-AD+B WD10.160	71MBT-B50WD1016			160	122	3.4	
	MAS403 BT50-AD+B WD12.70	71MBT-B50WD1207	12	34	70	32	3.1	
	MAS403 BT50-AD+B WD12.110	71MBT-B50WD1211			110	72	3.3	
	MAS403 BT50-AD+B WD12.160	71MBT-B50WD1216			160	122	3.6	
	MAS403 BT50-AD+B WD14.70	71MBT-B50WD1407	14	38	70	32	3.2	
	MAS403 BT50-AD+B WD14.110	71MBT-B50WD1411			110	72	3.5	
	MAS403 BT50-AD+B WD16.80	71MBT-B50WD1608	16	42	80	42	3.3	
	MAS403 BT50-AD+B WD16.110	71MBT-B50WD1611			110	72	3.5	
	MAS403 BT50-AD+B WD16.160	71MBT-B50WD1616			160	122	4	
	MAS403 BT50-AD+B WD18.80	71MBT-B50WD1808	18	46	80	42	3.4	
	MAS403 BT50-AD+B WD18.110	71MBT-B50WD1811			110	72	3.7	
	MAS403 BT50-AD+B WD20.80	71MBT-B50WD2008	20	50	80	42	3.5	
	MAS403 BT50-AD+B WD20.110	71MBT-B50WD2011			110	72	3.8	
	MAS403 BT50-AD+B WD20.160	71MBT-B50WD2016			160	122	4.5	
	MAS403 BT50-AD+B WD25.100	71MBT-B50WD2510	25	63	100	62	4.5	
	MAS403 BT50-AD+B WD25.125	71MBT-B50WD2512			125	87	5	
MAS403 BT50-AD+B WD25.160	71MBT-B50WD2516	160			122	5.7		
MAS403 BT50-AD+B WD32.100	71MBT-B50WD3210	32	70	100	62	5.6		
MAS403 BT50-AD+B WD32.160	71MBT-B50WD3216			160	122	7		
MAS403 BT50-AD+B WD40.110	71MBT-B50WD4011	40	80	110	72	5.8		
MAS403 BT50-AD+B WD40.160	71MBT-B50WD4016			160	122	7.4		

223

240

249



## MAS 403 BT AD+B PF

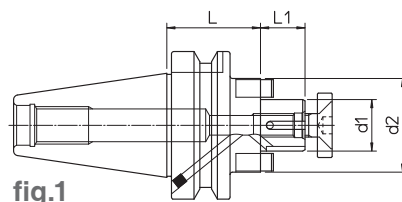


fig.1

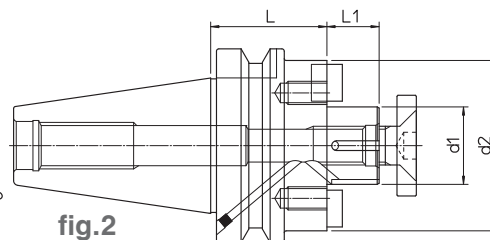
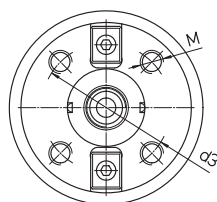


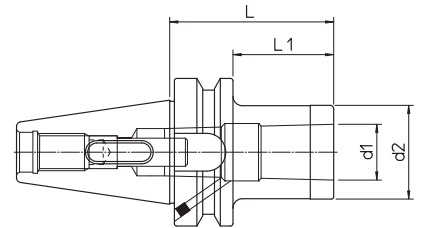
fig.2

BT	REF.	CODE	d1	d2	d3	M	L	L1	kg	fig.
40	MAS403 BT40-AD+B PF16.40	71MBT-B40PF1604	16	32	-	-	40	17	0.9	1
	MAS403 BT40-AD+B PF16.110	71MBT-B40PF1611					110		1.3	
	MAS403 BT40-AD+B PF16.160	71MBT-B40PF1616					160		1.6	
	MAS403 BT40-AD+B PF22.40	71MBT-B40PF2204	22	40			40	19	1	
	MAS403 BT40-AD+B PF22.110	71MBT-B40PF2211					110		1.6	
	MAS403 BT40-AD+B PF22.160	71MBT-B40PF2216					160		2.1	
	MAS403 BT40-AD+B PF27.45	71MBT-B40PF2704	27	50			45	21	1.2	
	MAS403 BT40-AD+B PF27.110	71MBT-B40PF2711					110		2.2	
	MAS403 BT40-AD+B PF27.160	71MBT-B40PF2716					160		2.9	
	MAS403 BT40-AD+B PF32.50	71MBT-B40PF3205	32	60			50	24	1.7	
	MAS403 BT40-AD+B PF32.110	71MBT-B40PF3211					110		3	
MAS403 BT40-AD+B PF40.55	71MBT-B40PF4005	40	70	55	27	2.1				
50	MAS403 BT50-AD+B PF16.50	71MBT-B50PF1605	16	32	50	17	2.4			
	MAS403 BT50-AD+B PF16.110	71MBT-B50PF1611			110		2.8			
	MAS403 BT50-AD+B PF16.160	71MBT-B50PF1616			160		3.1			
	MAS403 BT50-AD+B PF22.50	71MBT-B50PF2205	22	40	50	19	2.6			
	MAS403 BT50-AD+B PF22.110	71MBT-B50PF2211			110		3.2			
	MAS403 BT50-AD+B PF22.160	71MBT-B50PF2216			160		3.7			
	MAS403 BT50-AD+B PF27.55	71MBT-B50PF2705	27	50	55	21	2.7			
	MAS403 BT50-AD+B PF27.110	71MBT-B50PF2711			110		3.6			
	MAS403 BT50-AD+B PF27.160	71MBT-B50PF2716			160		4.3			
	MAS403 BT50-AD+B PF32.55	71MBT-B50PF3205	32	60	55	24	3.2			
	MAS403 BT50-AD+B PF32.120	71MBT-B50PF3212			120		5.5			
	MAS403 BT50-AD+B PF40.60	71MBT-B50PF4006	40	88	66.7	M12	60	27	4.3	
	MAS403 BT50-AD+B PF40.120	71MBT-B50PF4012					120	7.1		
MAS403 BT50-AD+B PF60.80	71MBT-B50PF6008	60	128.5	101.6	M16	80	40	6.8		



- MORSE TAPER TOOLHOLDER
- WERKZEUGAUFNAHME FÜR MORSEKEGEL
- PORTAHERRAMIENTA CONO MORSE
- PORTE-OUTIL CONE MORSE
- PORTAUTENSILE CONO MORSE

## MAS 403 BT AD+B CM - DIN 228 AB

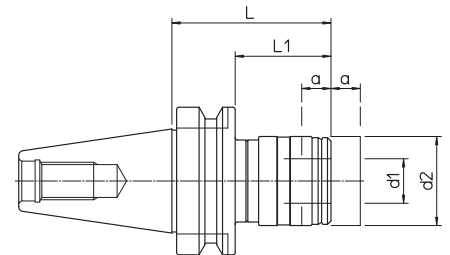


209

BT	REF.	CODE	MORSE	d1	d2	L	L1	kg
40	MAS403 BT40-AD+B CM2.50 A-B	71MBT-B40CMB205	2	17.780	32	50	23	1
	MAS403 BT40-AD+B CM2.125 A-B	71MBT-B40CMB212				125	98	1.3
	MAS403 BT40-AD+B CM3.70 A-B	71MBT-B40CMB307	3	23.825	40	70	43	1.1
	MAS403 BT40-AD+B CM3.140 A-B	71MBT-B40CMB314				140	113	1.5
50	MAS403 BT50-AD+B CM2.60 A-B	71MBT-B50CMB206	2	17.780	32	60	22	2.6
	MAS403 BT50-AD+B CM2.125 A-B	71MBT-B50CMB212				125	87	2.8
	MAS403 BT50-AD+B CM3.60 A-B	71MBT-B50CMB306	3	23.825	40	60	22	2.7
	MAS403 BT50-AD+B CM3.145 A-B	71MBT-B50CMB314				145	107	3.2
	MAS403 BT50-AD+B CM4.80 A-B	71MBT-B50CMB408	4	31.267	48	80	42	2.9

- TAPPING TOOLHOLDER
- AUFNAHME MIT GEWINDESCHNEIDSCHNELLWE
- PORTAHERRAMIENTA PARA ROSCAR
- PORTE-OUTIL DE TARAUDAGE
- PORTAUTENSILE MASCHIATORE

## MAS 403 BT MS



BT	REF.	CODE	d1	d2	L	L1	a	kg
40	MAS403 BT40 MS1 M3-12	71MBT-40-M10312	19	36	67.5	40.5	7.5	0.9
	MAS403 BT40 MS2 M8-20	71MBT-40-M20820	31	53	94.5	67.5	12.5	1.3
50	MAS403 BT50 MS1 M3-12	71MBT-50-M10312	19	38	80	42	7.5	2.8
	MAS403 BT50 MS2 M8-20	71MBT-50-M20820	31	53	102.5	64.5	12.5	3.1
	MAS403 BT50 MS3 M14-33	71MBT-50-M31433	48	78	154.5	116.5	20	4.3





# D'ANDREA

## MONOd'CT

- INDEX
- INHALTSVERZEICHNIS
- ÍNDICE
- INDEX
- INDICE

p. 240



p. 212

DIN 69893 HSK-A  
CT

p. 214

ISO 26623-1 PSC  
CT

p. 240



p. 216

DIN 69871 AD+B  
CT

p. 240



p. 218

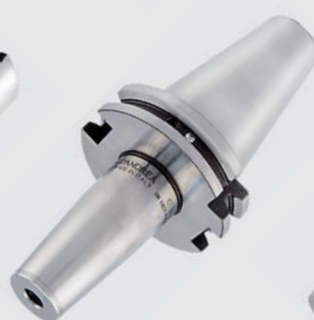
MAS 403 BT AD+B  
CT

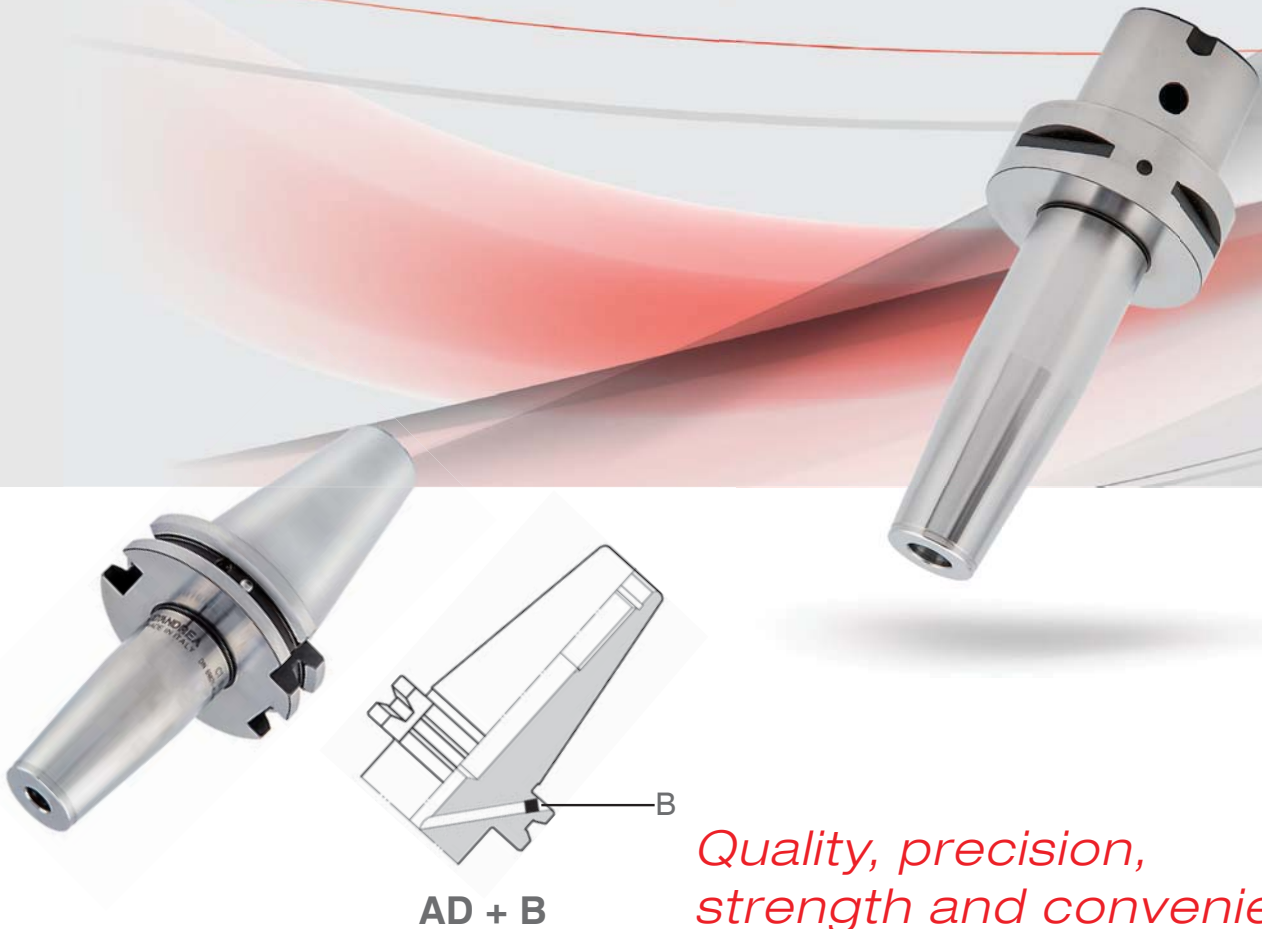


p. 220

PR CT

210





*Quality, precision,  
strength and convenience*

- SHRINK FIT CHUCKS
- SCHRUMPFSPANNFUTTER
- MANDRILA EMPALME TERMICO
- MANDRINS POUR FRETTAGE
- MANDRINI A CALETTAMENTO TERMICO

**GB** The integrated to fit chucks MONOd' CT tool holders represent an ideal solution to equip any type of machine tool with HSK 63 and 100, ISO 26623-1 PSC, DIN AD+B and BT AD+B base arbors, guaranteeing the benefits of a high quality and high precision.

**D** Die vollständigen Werkzeughalter auf schrumpfspannfutter MONOd' CT stellen die ideale Lösung zum Ausstatten jeder Art von Werkzeugmaschine mit Basisanschluss HSK 63 und 100, ISO 26623-1 PSC, DIN AD+B und BT AD+B dar und garantieren die Vorteile hoher Qualität und hohem Präzisionsgrad.

**E** Los portaherramientas integrales a empalme termico MONOd' CT representan la solución ideal para equipar cualquier tipo de máquina herramienta con unión base HSK 63 y 100, SO 26623-1 PSC, DIN AD+B y BT AD+B, garantizando las ventajas de elevada calidad y alto grado de precisión.

**F** Les porte-outils intégraux à frettage MONOd' CT représentent la solution idéale pour équiper tous les types de machine outils avec une fixation de base HSK 63 et 100, ISO 26623-1 PSC, DIN AD+B et BT AD+B, en garantissant les avantages de la qualité élevée et du haut niveau de précision.

**I** I portautensili integrali a calettamento termico MONOd' CT rappresentano la soluzione ideale per attrezzare ogni tipo di macchina utensile con attacco base HSK 63 e 100, ISO 26623-1 PSC, DIN AD+B e BT AD+B, garantendo i vantaggi di elevata qualità e alto grado di precisione.

## DIN 69893 HSK-A63

CT

0.003

RPM 25.000

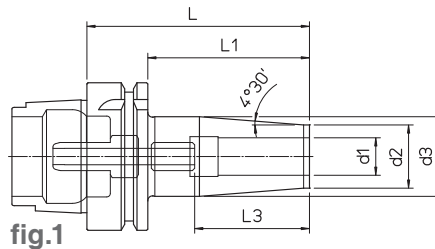


fig.1

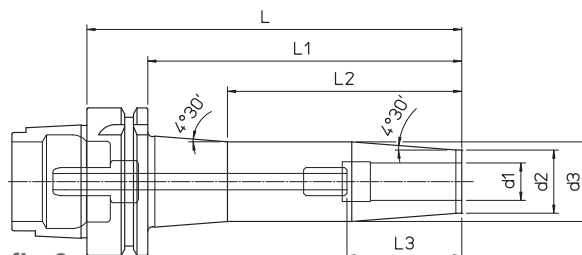


fig.2

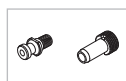
- Supplied with coolant tube
- Lieferung inklusive Kühlmittelrohr
- Completo con racor para el refrigerante
- Pourvu de raccord pour liquide d'arrosage
- Completo di raccordo per il refrigerante

HSK-A	REF.	CODE	d1	d2	d3	L	L1	L2	L3	kg	fig.	
63	HSK-A63 CT03.80	71HSKA063CT0308	3	10	-	80	54	-	9	0.7	1	
	HSK-A63 CT04.80	71HSKA063CT0408	4						12			
	HSK-A63 CT05.80	71HSKA063CT0508	5						15			
	HSK-A63 CT06.80	71HSKA063CT0608	6	21	27	120	94	-	22 / 36	0.8	1	
	HSK-A63 CT06.120	71HSKA063CT0612								1		
	HSK-A63 CT06.160	71HSKA063CT0616								1.2		
	HSK-A63 CT06.200	71HSKA063CT0620	1.4	2								
	HSK-A63 CT08.80	71HSKA063CT0808	8		21	27	80	54	-	26 / 36	0.8	1
	HSK-A63 CT08.120	71HSKA063CT0812									1	
	HSK-A63 CT08.160	71HSKA063CT0816		1.2								
	HSK-A63 CT08.200	71HSKA063CT0820	1.4	2								
	HSK-A63 CT10.85	71HSKA063CT1008	10		24	32	85	59	-	31 / 41	0.9	1
	HSK-A63 CT10.120	71HSKA063CT1012									1.1	
	HSK-A63 CT10.160	71HSKA063CT1016		1.4								
	HSK-A63 CT10.200	71HSKA063CT1020	1.6	2								
	HSK-A63 CT12.90	71HSKA063CT1209	12		24	32	90	64	-	36 / 46	0.9	1
	HSK-A63 CT12.120	71HSKA063CT1212									1.1	
	HSK-A63 CT12.160	71HSKA063CT1216		1.3								
	HSK-A63 CT12.200	71HSKA063CT1220	1.6	2								
	HSK-A63 CT14.90	71HSKA063CT1409	14		27	34	90	64	-	36 / 46	0.9	1
	HSK-A63 CT14.120	71HSKA063CT1412									1.1	
	HSK-A63 CT14.160	71HSKA063CT1416		1.4								
	HSK-A63 CT16.95	71HSKA063CT1609	16	27	34	95	69	-	39 / 49	0.9	1	
	HSK-A63 CT16.120	71HSKA063CT1612								1.1		
	HSK-A63 CT16.160	71HSKA063CT1616								1.4		
	HSK-A63 CT16.200	71HSKA063CT1620	1.7	2								
	HSK-A63 CT18.95	71HSKA063CT1809	18		33	42	95	69	-	39 / 49	1.1	1
	HSK-A63 CT18.120	71HSKA063CT1812									1.4	
HSK-A63 CT18.160	71HSKA063CT1816	1.8										
HSK-A63 CT20.100	71HSKA063CT2010	20	33	42	100	74	-	41 / 51	1.4	1		
HSK-A63 CT20.120	71HSKA063CT2012								1.3			
HSK-A63 CT20.160	71HSKA063CT2016								1.8			
HSK-A63 CT20.200	71HSKA063CT2020	2.2	2									
HSK-A63 CT25.120	71HSKA063CT2512	25		44	53	120	94	-	47 / 57	1.8	1	
HSK-A63 CT25.160	71HSKA063CT2516									2.5		

248

240

223



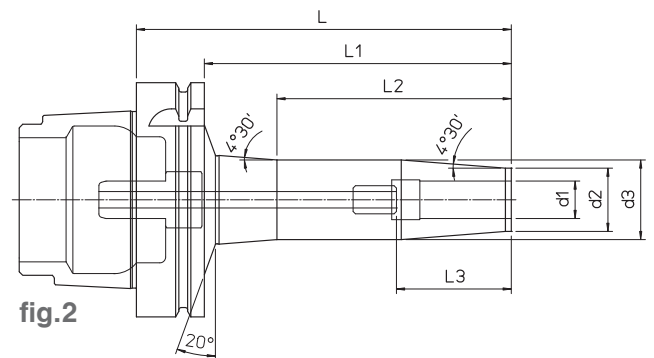
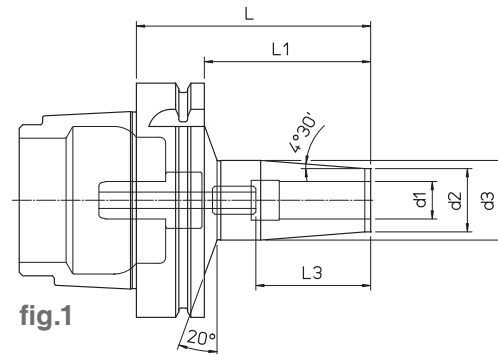
- SHRINK FIT CHUCKS
- SCHRUMPFSPANNFUTTER
- MANDRILA EMPALME TERMICO
- MANDRINS POUR FRETTAGE
- MANDRINI A CALETTAMENTO TERMICO

DIN 69893 HSK-A100

CT

0.003

RPM 12.000



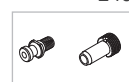
- Supplied with coolant tube
- Lieferung inklusive Kühlmittelrohr
- Completo con racor para el refrigerante
- Pourvu de raccord pour liquide d'arrosage
- Completo di raccordo per il refrigerante

HSK-A	REF.	CODE	d1	d2	d3	L	L1	L2	L3	kg	fig.		
100	HSK-A100 CT06.85	71HSKA100CT0608	6	21	27	85	56	-	22 / 36	2.2	1		
	HSK-A100 CT06.120	71HSKA100CT0612				120	91	2.4					
	HSK-A100 CT06.160	71HSKA100CT0616				160	131	100		2.5			
	HSK-A100 CT08.85	71HSKA100CT0808	8			24	32	85	56	-	26 / 36	2.2	1
	HSK-A100 CT08.120	71HSKA100CT0812						120	91	2.4			
	HSK-A100 CT08.160	71HSKA100CT0816						160	131	100		2.5	
	HSK-A100 CT10.90	71HSKA100CT1009	10	27	34			90	61	-	31 / 41	2.3	1
	HSK-A100 CT10.120	71HSKA100CT1012						120	91	2.5			
	HSK-A100 CT10.160	71HSKA100CT1016						160	131	100		2.7	
	HSK-A100 CT12.95	71HSKA100CT1209	12			33	42	95	66	-	36 / 46	2.3	1
	HSK-A100 CT12.120	71HSKA100CT1212						120	91	2.5			
	HSK-A100 CT12.160	71HSKA100CT1216						160	134	100		2.7	
	HSK-A100 CT14.95	71HSKA100CT1409	14	44	53			95	66	-	39 / 49	2.3	1
	HSK-A100 CT14.120	71HSKA100CT1412						120	91	2.5			
	HSK-A100 CT14.160	71HSKA100CT1416						160	131	100		2.8	
	HSK-A100 CT16.100	71HSKA100CT1610	16			44	53	100	71	-	41 / 51	2.3	1
	HSK-A100 CT16.120	71HSKA100CT1612						120	91	2.5			
	HSK-A100 CT16.160	71HSKA100CT1616						160	131	100		2.8	
	HSK-A100 CT18.100	71HSKA100CT1810	18	44	53			100	71	-	47 / 57	2.5	1
	HSK-A100 CT18.120	71HSKA100CT1812						120	91	2.8			
	HSK-A100 CT18.160	71HSKA100CT1816						160	131	100		3.1	
	HSK-A100 CT20.120	71HSKA100CT2012	20			44	53	120	91	-	51 / 61	2.7	1
	HSK-A100 CT20.160	71HSKA100CT2016						160	131	100		3.1	
	HSK-A100 CT25.120	71HSKA100CT2512						120	91	-		3.1	
HSK-A100 CT25.160	71HSKA100CT2516	160	131	100	3.8								
HSK-A100 CT32.120	71HSKA100CT3212	120	91	-	2.9			1					
HSK-A100 CT32.160	71HSKA100CT3216	160	131	100	3.5								

223

240

248



↗ 0.003

RPM 25.000

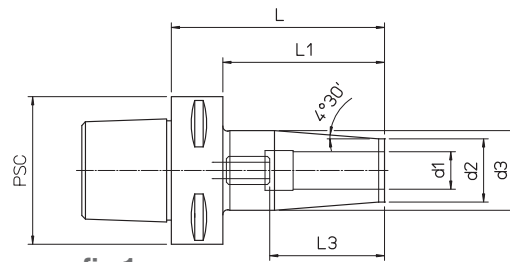


fig.1

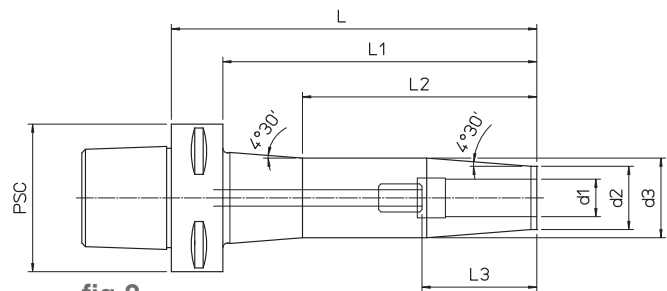


fig.2

PSC	REF.	CODE	d1	d2	d3	L	L1	L2	L3	kg	fig.
63	PSC 63 CT03.80	71PSC-063CT0308	3			80	58	-	9	0.8	1
	PSC 63 CT04.80	71PSC-063CT0408	4						12		
	PSC 63 CT05.80	71PSC-063CT0508	5						15		
	PSC 63 CT06.80	71PSC-063CT0608	6	21	27	120	98	100	22 / 36	1	1
	PSC 63 CT06.120	71PSC-063CT0612	6			160	138		1.2	2	
	PSC 63 CT06.160	71PSC-063CT0616	6			160	138		100	26 / 36	1.2
	PSC 63 CT08.80	71PSC-063CT0808	8	21	27	80	58	-	26 / 36	0.8	1
	PSC 63 CT08.120	71PSC-063CT0812	8			120	98			1	
	PSC 63 CT08.160	71PSC-063CT0816	8			160	138			100	
	PSC 63 CT10.80	71PSC-063CT1008	10	24	32	80	58	-	31 / 41	0.9	1
	PSC 63 CT10.120	71PSC-063CT1012	10			120	98			1.1	
	PSC 63 CT10.160	71PSC-063CT1016	10			160	138			100	
	PSC 63 CT12.85	71PSC-063CT1208	12	24	32	85	63	-	36 / 46	0.9	1
	PSC 63 CT12.120	71PSC-063CT1212	12			120	98			1.1	
	PSC 63 CT12.160	71PSC-063CT1216	12			160	138			100	
	PSC 63 CT14.85	71PSC-063CT1408	14	27	34	85	63	-	36 / 46	0.9	1
	PSC 63 CT14.120	71PSC-063CT1412	14			120	98			1.1	
	PSC 63 CT14.160	71PSC-063CT1416	14			160	138			100	
	PSC 63 CT16.85	71PSC-063CT1608	16	27	34	85	63	-	39 / 49	0.9	1
	PSC 63 CT16.120	71PSC-063CT1612	16			120	98			1.1	
	PSC 63 CT16.160	71PSC-063CT1616	16			160	138			100	
	PSC 63 CT18.90	71PSC-063CT1809	18	33	42	90	68	-	39 / 49	1.1	1
	PSC 63 CT18.120	71PSC-063CT1812	18			120	98			1.4	
	PSC 63 CT18.160	71PSC-063CT1816	18			160	138			100	
	PSC 63 CT20.90	71PSC-063CT2009	20	33	42	90	68	-	41 / 51	1.4	1
	PSC 63 CT20.120	71PSC-063CT2012	20			120	98			1.3	
	PSC 63 CT20.160	71PSC-063CT2016	20			160	138			100	
	PSC 63 CT25.120	71PSC-063CT2512	25	44	53	120	98	-	47 / 57	1.4	1
	PSC 63 CT25.160	71PSC-063CT2516	25			160	138			1.8	



- SHRINK FIT CHUCKS
- SCHRUMPFSPANNFUTTER
- MANDRILA EMPALME TERMICO
- MANDRINS POUR FRETTAGE
- MANDRINI A CALETTAMENTO TERMICO

ISO 26623-1 PSC80

CT

0.003

RPM 12.000

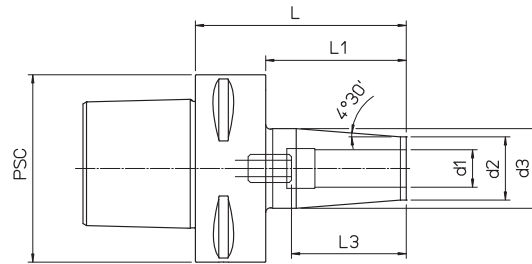


fig.1

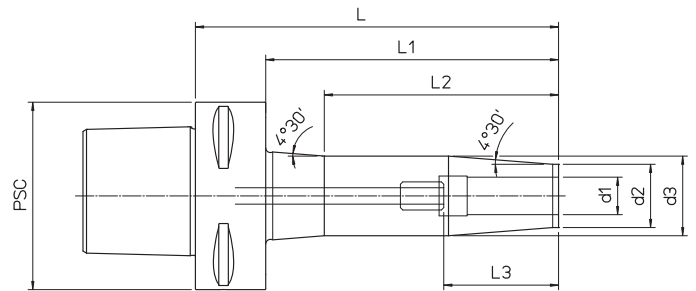


fig.2

215

PSC	REF.	CODE	d1	d2	d3	L	L1	L2	L3	kg	fig.		
80	PSC 80 CT06.80	71PSC-080CT0608	6	21	27	80	50	-	22 / 36	2.2	1		
	PSC 80 CT06.120	71PSC-080CT0612				120	90	2.4					
	PSC 80 CT06.160	71PSC-080CT0616				160	130	100		2.5			
	PSC 80 CT08.80	71PSC-080CT0808	8			24	32	80	50	-	26 / 36	2.2	1
	PSC 80 CT08.120	71PSC-080CT0812						120	90	2.4			
	PSC 80 CT08.160	71PSC-080CT0816						160	130	100		2.5	
	PSC 80 CT10.90	71PSC-080CT1009	10	27	34			90	60	-	31 / 41	2.3	1
	PSC 80 CT10.120	71PSC-080CT1012						120	90	2.5			
	PSC 80 CT10.160	71PSC-080CT1016						160	130	100		2.7	
	PSC 80 CT12.90	71PSC-080CT1209	12			33	42	90	60	-	36 / 46	2.3	1
	PSC 80 CT12.120	71PSC-080CT1212						120	90	2.5			
	PSC 80 CT12.160	71PSC-080CT1216						160	130	100		2.7	
	PSC 80 CT14.90	71PSC-080CT1409	14	44	53			90	60	-	39 / 49	2.3	1
	PSC 80 CT14.120	71PSC-080CT1412						120	90	2.5			
	PSC 80 CT14.160	71PSC-080CT1416						160	130	100		2.8	
	PSC 80 CT16.90	71PSC-080CT1609	16			53	53	90	60	-	41 / 51	2.3	1
	PSC 80 CT16.120	71PSC-080CT1612						120	90	2.5			
	PSC 80 CT16.160	71PSC-080CT1616						160	130	100		2.8	
	PSC 80 CT18.95	71PSC-080CT1809	18	53	53			95	65	-	47 / 57	2.5	1
	PSC 80 CT18.120	71PSC-080CT1812						120	90	2.8			
	PSC 80 CT18.160	71PSC-080CT1816						160	130	100		3.1	
	PSC 80 CT20.95	71PSC-080CT2009	20			53	53	95	65	-	51 / 61	2.5	1
	PSC 80 CT20.120	71PSC-080CT2012						120	90	2.8			
	PSC 80 CT20.160	71PSC-080CT2016						160	130	100		3.1	
PSC 80 CT25.120	71PSC-080CT2512	25	53	53	120			90	-	47 / 57	3.1	1	
PSC 80 CT25.160	71PSC-080CT2516				160			130	100		3.8		
PSC 80 CT32.120	71PSC-080CT3212	32			53			53	120	90	-	51 / 61	2.9
PSC 80 CT32.160	71PSC-080CT3216					160	130		100	3.5			





- SHRINK FIT CHUCKS
- SCHRUMPFSPANNFUTTER
- MANDRILA EMPALME TERMICO
- MANDRINS POUR FRETTAGE
- MANDRINI A CALETTAMENTO TERMICO

DIN 69871 AD+B40

CT

0.003

RPM 25.000

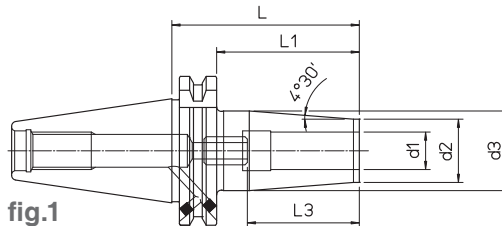


fig.1

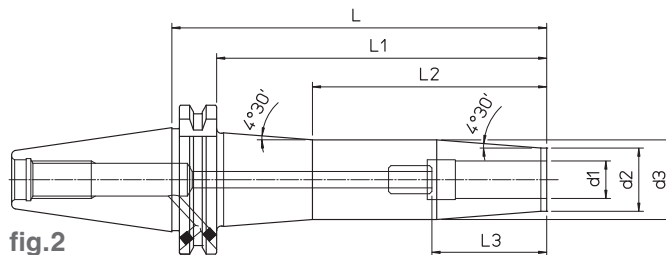


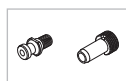
fig.2

DIN	REF.	CODE	d1	d2	d3	L	L1	L2	L3	kg	fig.
40	DIN69871-AD+B40 CT03.80	71DIN-B40CT0308	3	10	-	80	61	-	9	0.8	1
	DIN69871-AD+B40 CT04.80	71DIN-B40CT0408	4						12		
	DIN69871-AD+B40 CT05.80	71DIN-B40CT0508	5						15		
	DIN69871-AD+B40 CT06.80	71DIN-B40CT0608	6	21	27	120	101	100	22 / 36	1	1
	DIN69871-AD+B40 CT06.120	71DIN-B40CT0612								1.2	
	DIN69871-AD+B40 CT06.160	71DIN-B40CT0616								1.6	
	DIN69871-AD+B40 CT06.200	71DIN-B40CT0620	8	21	27	200	181	110	26 / 36	1.6	2
	DIN69871-AD+B40 CT08.80	71DIN-B40CT0808								0.8	
	DIN69871-AD+B40 CT08.120	71DIN-B40CT0812								1	
	DIN69871-AD+B40 CT08.160	71DIN-B40CT0816	10	24	32	120	101	100	31 / 41	1.2	1
	DIN69871-AD+B40 CT08.200	71DIN-B40CT0820								1.6	
	DIN69871-AD+B40 CT10.80	71DIN-B40CT1008								0.8	
	DIN69871-AD+B40 CT10.120	71DIN-B40CT1012	12	24	32	160	141	100	36 / 46	1.1	2
	DIN69871-AD+B40 CT10.160	71DIN-B40CT1016								1.4	
	DIN69871-AD+B40 CT10.200	71DIN-B40CT1020								1.8	
	DIN69871-AD+B40 CT12.80	71DIN-B40CT1208	14	27	34	80	61	-	36 / 46	0.9	1
	DIN69871-AD+B40 CT12.120	71DIN-B40CT1212								1.1	
	DIN69871-AD+B40 CT12.160	71DIN-B40CT1216								1.4	
	DIN69871-AD+B40 CT12.200	71DIN-B40CT1220	16	27	34	160	141	100	39 / 49	1.3	2
	DIN69871-AD+B40 CT14.80	71DIN-B40CT1408								0.9	
	DIN69871-AD+B40 CT14.120	71DIN-B40CT1412								1.1	
	DIN69871-AD+B40 CT14.160	71DIN-B40CT1416	18	27	34	200	181	125	39 / 49	1.4	1
	DIN69871-AD+B40 CT16.80	71DIN-B40CT1608								0.9	
	DIN69871-AD+B40 CT16.120	71DIN-B40CT1612								1.1	
DIN69871-AD+B40 CT16.160	71DIN-B40CT1616	20	33	42	160	141	100	41 / 51	1.4	2	
DIN69871-AD+B40 CT16.200	71DIN-B40CT1620								1.9		
DIN69871-AD+B40 CT18.80	71DIN-B40CT1808								0.9		
DIN69871-AD+B40 CT18.120	71DIN-B40CT1812	25	44	53	80	61	-	47 / 57	1.1	1	
DIN69871-AD+B40 CT18.160	71DIN-B40CT1816								1.4		
DIN69871-AD+B40 CT20.80	71DIN-B40CT2008								1.3		
DIN69871-AD+B40 CT20.120	71DIN-B40CT2012	20	33	42	120	101	-	41 / 51	1.4	1	
DIN69871-AD+B40 CT20.160	71DIN-B40CT2016								1.8		
DIN69871-AD+B40 CT20.200	71DIN-B40CT2020								2.4		
DIN69871-AD+B40 CT25.100	71DIN-B40CT2510	25	44	53	100	81	-	47 / 57	1.8	1	

249

240

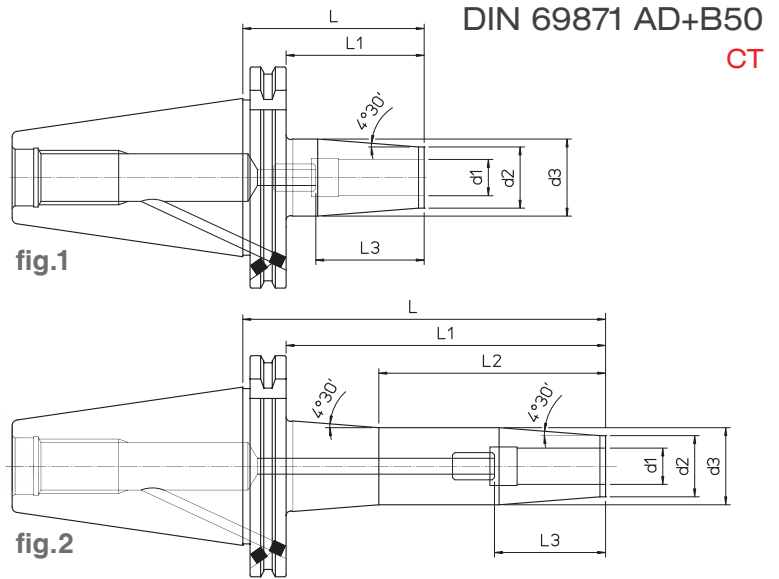
223



- SHRINK FIT CHUCKS
- SCHRUMPFSPANNFUTTER
- MANDRILA EMPALME TERMICO
- MANDRINS POUR FRETTAGE
- MANDRINI A CALETTAMENTO TERMICO

↗ 0.003

RPM 12.000



DIN 69871 AD+B50

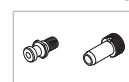
CT

DIN	REF.	CODE	d1	d2	d3	L	L1	L2	L3	kg	fig.
50	DIN69871-AD+B50 CT06.80	71DIN-B50CT0608	6	21	27	80	61	-	22 / 36	2.2	1
	DIN69871-AD+B50 CT06.120	71DIN-B50CT0612				120	101	-		2.4	
	DIN69871-AD+B50 CT06.160	71DIN-B50CT0616				160	141	100	2.5	2	
	DIN69871-AD+B50 CT06.200	71DIN-B50CT0620				200	181	110	3.4		
	DIN69871-AD+B50 CT08.80	71DIN-B50CT0808	8	21	27	80	61	-	26 / 36	2.2	1
	DIN69871-AD+B50 CT08.120	71DIN-B50CT0812				120	101	-		2.4	
	DIN69871-AD+B50 CT08.160	71DIN-B50CT0816				160	141	100	2.5	2	
	DIN69871-AD+B50 CT08.200	71DIN-B50CT0820				200	181	110	3.4		
	DIN69871-AD+B50 CT10.80	71DIN-B50CT1008	10	24	32	80	61	-	31 / 41	2.3	1
	DIN69871-AD+B50 CT10.120	71DIN-B50CT1012				120	101	-		2.5	
	DIN69871-AD+B50 CT10.160	71DIN-B50CT1016				160	141	100	2.7	2	
	DIN69871-AD+B50 CT10.200	71DIN-B50CT1020				200	181	125	3.6		
	DIN69871-AD+B50 CT12.80	71DIN-B50CT1208	12	24	32	80	61	-	36 / 46	2.3	1
	DIN69871-AD+B50 CT12.120	71DIN-B50CT1212				120	101	-		2.5	
	DIN69871-AD+B50 CT12.160	71DIN-B50CT1216				160	141	100	2.7	2	
	DIN69871-AD+B50 CT12.200	71DIN-B50CT1220				200	181	125	3.6		
	DIN69871-AD+B50 CT14.80	71DIN-B50CT1408	14	27	34	80	61	-	36 / 46	2.3	1
	DIN69871-AD+B50 CT14.120	71DIN-B50CT1412				120	101	-		2.5	
	DIN69871-AD+B50 CT14.160	71DIN-B50CT1416				160	141	100	2.8	2	
	DIN69871-AD+B50 CT16.80	71DIN-B50CT1608				16	27	34	80		61
	DIN69871-AD+B50 CT16.120	71DIN-B50CT1612	120	101	-				2.5		
	DIN69871-AD+B50 CT16.160	71DIN-B50CT1616	160	141	100				2.8	2	
	DIN69871-AD+B50 CT16.200	71DIN-B50CT1620	200	181	125				3.7		
	DIN69871-AD+B50 CT18.80	71DIN-B50CT1808	18	33	42	80	61	-	39 / 49	2.5	1
DIN69871-AD+B50 CT18.120	71DIN-B50CT1812	120				101	-	2.8			
DIN69871-AD+B50 CT18.160	71DIN-B50CT1816	160				141	100	3.1	2		
DIN69871-AD+B50 CT20.80	71DIN-B50CT2008	20				33	42	80		61	-
DIN69871-AD+B50 CT20.120	71DIN-B50CT2012		120	101	-			2.8			
DIN69871-AD+B50 CT20.160	71DIN-B50CT2016		160	141	100			3.1	2		
DIN69871-AD+B50 CT20.200	71DIN-B50CT2020		200	181	125			4.2			
DIN69871-AD+B50 CT25.120	71DIN-B50CT2512	25	44	53	120	101	-	47 / 57	3.1	1	
DIN69871-AD+B50 CT25.160	71DIN-B50CT2516				160	141	100		2.8		
DIN69871-AD+B50 CT25.200	71DIN-B50CT2520				200	181	125	5.2	2		
DIN69871-AD+B50 CT32.120	71DIN-B50CT3212	32	44	53	120	101	-	51 / 61		2.9	1
DIN69871-AD+B50 CT32.160	71DIN-B50CT3216				160	141	100		3.5	2	

223

240

249



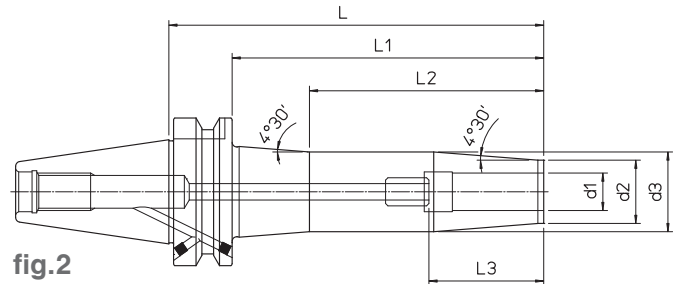
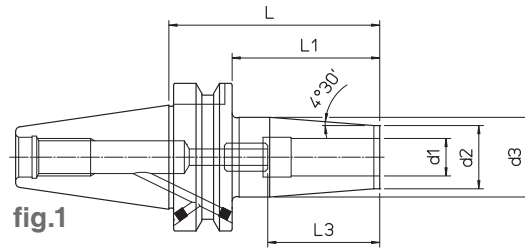
- SHRINK FIT CHUCKS
- SCHRUMPFSPANNFUTTER
- MANDRILA EMPALME TERMICO
- MANDRINS POUR FRETTAGE
- MANDRINI A CALETTAMENTO TERMICO

### MAS 403 BT40 AD+B

CT

0.003

RPM 25.000

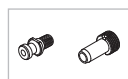


BT	REF.	CODE	d1	d2	d3	L	L1	L2	L3	kg	fig.
40	MAS403 BT40-AD+B CT03.90	71MBT-B40CT0309	3	10	-	90	63	-	9	1	1
	MAS403 BT40-AD+B CT04.90	71MBT-B40CT0409	4						12		
	MAS403 BT40-AD+B CT05.90	71MBT-B40CT0509	5						15		
	MAS403 BT40-AD+B CT06.90	71MBT-B40CT0609	6	21	27	120	93	-	22 / 36	0.8	1
	MAS403 BT40-AD+B CT06.120	71MBT-B40CT0612								1	
	MAS403 BT40-AD+B CT06.160	71MBT-B40CT0616								1.2	
	MAS403 BT40-AD+B CT06.200	71MBT-B40CT0620	1.7	2							
	MAS403 BT40-AD+B CT08.90	71MBT-B40CT0809	8		21	27	90	63	-	0.8	1
	MAS403 BT40-AD+B CT08.120	71MBT-B40CT0812					120	93	-	1	
	MAS403 BT40-AD+B CT08.160	71MBT-B40CT0816		160			133	100	26 / 36	1.2	
	MAS403 BT40-AD+B CT08.200	71MBT-B40CT0820	1.7	2							
	MAS403 BT40-AD+B CT10.90	71MBT-B40CT1009	10		24	32	90	63	-	0.9	1
	MAS403 BT40-AD+B CT10.120	71MBT-B40CT1012					120	93	-	31 / 41	
	MAS403 BT40-AD+B CT10.160	71MBT-B40CT1016		160			133	100	31 / 41	1.4	
	MAS403 BT40-AD+B CT10.200	71MBT-B40CT1020	1.9	2							
	MAS403 BT40-AD+B CT12.90	71MBT-B40CT1209	12		24	32	90	63	-	0.9	1
	MAS403 BT40-AD+B CT12.120	71MBT-B40CT1212					120	93	-	36 / 46	
	MAS403 BT40-AD+B CT12.160	71MBT-B40CT1216		160			133	100	36 / 46	1.3	
	MAS403 BT40-AD+B CT12.200	71MBT-B40CT1220	1.9	2							
	MAS403 BT40-AD+B CT14.90	71MBT-B40CT1409	14		27	34	90	63	-	0.9	1
	MAS403 BT40-AD+B CT14.120	71MBT-B40CT1412					120	93	-	31 / 41	
	MAS403 BT40-AD+B CT14.160	71MBT-B40CT1416		160			133	100	31 / 41	1.4	
	MAS403 BT40-AD+B CT16.90	71MBT-B40CT1609	16	27	34	90	63	-	0.9	1	
	MAS403 BT40-AD+B CT16.120	71MBT-B40CT1612				120	93	-	39 / 49		1.1
	MAS403 BT40-AD+B CT16.160	71MBT-B40CT1616				160	133	100	39 / 49		1.4
	MAS403 BT40-AD+B CT16.200	71MBT-B40CT1620	2	2							
	MAS403 BT40-AD+B CT18.90	71MBT-B40CT1809	18		33	42	90	63	-	1.1	1
	MAS403 BT40-AD+B CT18.120	71MBT-B40CT1812					120	93	-	39 / 49	
	MAS403 BT40-AD+B CT18.160	71MBT-B40CT1816		160			133	100	39 / 49	1.8	
	MAS403 BT40-AD+B CT20.90	71MBT-B40CT2009	20	33	42	90	63	-	1.4	1	
MAS403 BT40-AD+B CT20.120	71MBT-B40CT2012	120				93	-	41 / 51	1.3		
MAS403 BT40-AD+B CT20.160	71MBT-B40CT2016	160				133	100	41 / 51	1.8		
MAS403 BT40-AD+B CT20.200	71MBT-B40CT2020	2.4	2								
MAS403 BT40-AD+B CT25.100	71MBT-B40CT2510	25		44	53	100	73	-	47 / 57	1.8	1

249

240

223



- SHRINK FIT CHUCKS
- SCHRUMPFSPANNFUTTER
- MANDRILA EMPALME TERMICO
- MANDRINS POUR FRETTAGE
- MANDRINI A CALETTAMENTO TERMICO

## MAS 403 BT50 AD+B

CT

0.003

RPM 12.000

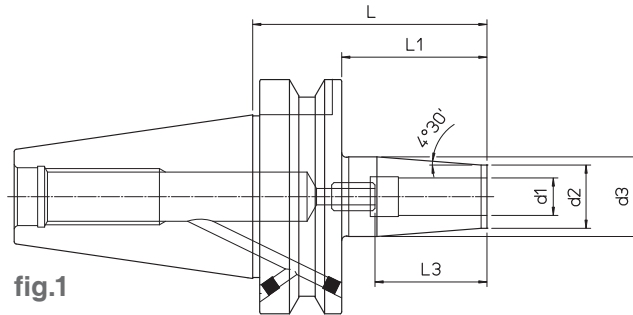


fig.1

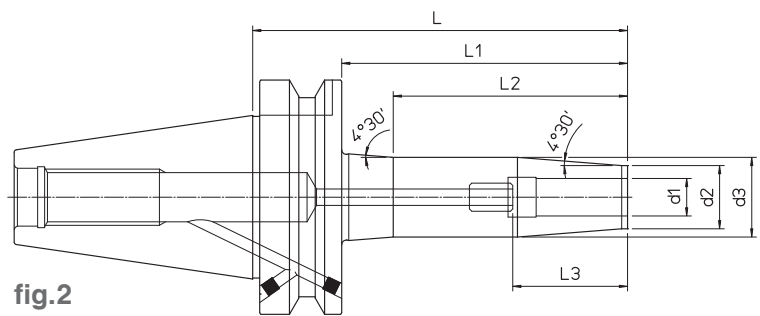


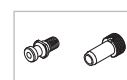
fig.2

BT	REF.	CODE	d1	d2	d3	L	L1	L2	L3	kg	fig.
50	MAS403 BT50-AD+B CT06.100	71MBT-B50CT0610	6	21	27	100	62	-	22 / 36	2.2	1
	MAS403 BT50-AD+B CT06.160	71MBT-B50CT0616				160	122	100		2.5	2
	MAS403 BT50-AD+B CT06.200	71MBT-B50CT0620				200	162	110		4.2	2
	MAS403 BT50-AD+B CT08.100	71MBT-B50CT0810	8	21	27	100	62	-	26 / 36	2.2	1
	MAS403 BT50-AD+B CT08.160	71MBT-B50CT0816				160	122	100		2.5	2
	MAS403 BT50-AD+B CT08.200	71MBT-B50CT0820				200	162	110		4.2	2
	MAS403 BT50-AD+B CT10.100	71MBT-B50CT1010	10	24	32	100	62	-	31 / 41	2.3	1
	MAS403 BT50-AD+B CT10.160	71MBT-B50CT1016				160	122	100		2.7	2
	MAS403 BT50-AD+B CT10.200	71MBT-B50CT1020				200	162	125		4.4	2
	MAS403 BT50-AD+B CT12.100	71MBT-B50CT1210	12	24	32	100	62	-	36 / 46	2.3	1
	MAS403 BT50-AD+B CT12.160	71MBT-B50CT1216				160	122	100		2.7	2
	MAS403 BT50-AD+B CT12.200	71MBT-B50CT1220				200	162	125		4.4	2
	MAS403 BT50-AD+B CT14.100	71MBT-B50CT1410	14	27	34	100	62	-	36 / 46	2.3	1
	MAS403 BT50-AD+B CT14.160	71MBT-B50CT1416				160	122	100		2.8	2
	MAS403 BT50-AD+B CT16.100	71MBT-B50CT1610				16	27	34		100	62
	MAS403 BT50-AD+B CT16.160	71MBT-B50CT1616	160	122	100				2.8	2	
	MAS403 BT50-AD+B CT16.200	71MBT-B50CT1620	200	162	125				4.5	2	
	MAS403 BT50-AD+B CT18.100	71MBT-B50CT1810	18	27	34	100	62	-	39 / 49	2.5	1
	MAS403 BT50-AD+B CT18.160	71MBT-B50CT1816				160	122	100		3.1	2
	MAS403 BT50-AD+B CT20.120	71MBT-B50CT2012				20	33	42		120	82
MAS403 BT50-AD+B CT20.160	71MBT-B50CT2016	160	122	100	3.1				2		
MAS403 BT50-AD+B CT20.200	71MBT-B50CT2020	200	162	125	4.9				2		
MAS403 BT50-AD+B CT25.120	71MBT-B50CT2512	25	44	53	120	82	-	47 / 57	3.1	1	
MAS403 BT50-AD+B CT25.160	71MBT-B50CT2516				160	122	100		3.8	2	
MAS403 BT50-AD+B CT25.200	71MBT-B50CT2520				200	162	125		5.8	2	
MAS403 BT50-AD+B CT32.120	71MBT-B50CT3212	32	44	53	120	82	-	51 / 61	2.9	1	
MAS403 BT50-AD+B CT32.160	71MBT-B50CT3216				160	122	100		3.5	2	

223

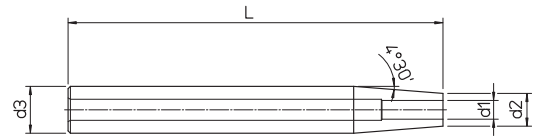
240

249



- SHRINK FIT EXTENSIONS
- SCHRUMPFVERLÄNGERUNGEN
- ENCHUFE ALARGADOR CON ACOPLAMIENTO TÉRMICO.
- RALLONGES À FRETAGE THERMIQUE
- PROLUNGHE A CALETTAMENTO TERMICO

PR CT N



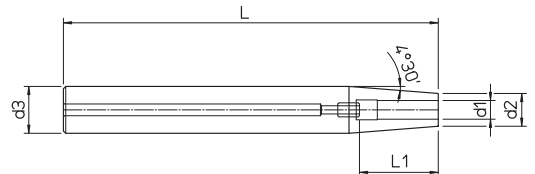
220

REF.	CODE	d1	d2	d3	L	kg
PR.CT.N D12.03.160	49DC11612030	3	8	12	160	0.09
PR.CT.N D12.04.160	49DC11612040	4				
PR.CT.N D16.03.160	49DC11616030	3	10	16		0.14
PR.CT.N D16.04.160	49DC11616040	4				
PR.CT.N D16.05.160	49DC11616050	5	12	16		0.15
PR.CT.N D16.06.160	49DC11616060	6				
PR.CT.N D16.08.160	49DC11616080	8	14	20		0.16
PR.CT.N D20.05.160	49DC11620050	5				
PR.CT.N D20.06.160	49DC11620060	6	16	20		0.27
PR.CT.N D20.08.160	49DC11620080	8				
PR.CT.N D20.10.160	49DC11620100	10	18	20		0.26
PR.CT.N D20.12.160	49DC11620120	12				



- SHRINK FIT EXTENSIONS WITH AXIAL ADJUSTMENT
- SCHRUMPFVERLÄNGERUNG MIT AXIALER EINSTELLUNG
- ENCHUFE ALARGADOR CON ACOPLAMIENTO TÉRMICO DE REGULACIÓN AXIAL
- RALLONGES À FRETAGE THERMIQUE À RÉGLAGE AXIAL
- PROLUNGHE A CALETTAMENTO TERMICO A REGOLAZIONE ASSIALE

PR CT R



221

REF.	CODE	d1	d2	d3	L	L1	kg
PR.CT.R D16.06.130	49DC21316060	6	10	16	130	22 / 36	0.18
PR.CT.R D16.06.160	49DC21616060				160		0.17
PR.CT.R D20.06.130	49DC21320060				130		0.20
PR.CT.R D20.08.130	49DC21320080	8	14	20	130	22 / 32	0.25
PR.CT.R D20.06.160	49DC21620060	6					0.33
PR.CT.R D20.08.160	49DC21620080	8					0.32
PR.CT.R D25.10.130	49DC21325100	10	20	25	130	31 / 41	0.40
PR.CT.R D25.12.130	49DC21325120	12					0.37
PR.CT.R D25.16.130	49DC21325160	16					0.32
PR.CT.R D25.08.160	49DC21625080	8	19	20	160	26 / 36	0.53
PR.CT.R D25.10.160	49DC21625100	10					0.51
PR.CT.R D25.12.160	49DC21625120	12					0.48
PR.CT.R D25.14.160	49DC21625140	14	22	25	160	36 / 46	0.47
PR.CT.R D25.16.160	49DC21625160	16					0.43
PR.CT.R D25.08.200	49DC22025080	8					19
PR.CT.R D25.10.200	49DC22025100	10	20	31 / 41	0.64		
PR.CT.R D25.12.200	49DC22025120	12			22	36 / 46	0.60
PR.CT.R D25.16.200	49DC22025160	16					0.52
PR.CT.R D32.16.160	49DC21632160	16	27	32			160
PR.CT.R D32.18.160	49DC21632180	18			0.77		
PR.CT.R D32.20.160	49DC21632200	20			200	41 / 51	
PR.CT.R D32.16.200	49DC22032160	16	39 / 49	1.81			
PR.CT.R D32.20.200	49DC22032200	20		41 / 51			0.87





- SEALING DEVICE FOR HIGH PRESSURE COOLANT SUPPLY
- DICHTVORRICHTUNG FÜR HOCHDRUCK-KÜHLMITTELZUFUHR
- DISPOSITIVOS DE RETENCIÓN PARA REFRIGERANTE A ALTA PRESIÓN
- SYSTÈME D'ÉTANCHÉITÉ POUR L'ALIMENTATION DE REFROIDISSEMENT HAUTE PRESSION
- DISPOSITIVI A TENUTA PER REFRIGERANTE AD ALTA PRESSIONE

## FORCE GH - VT

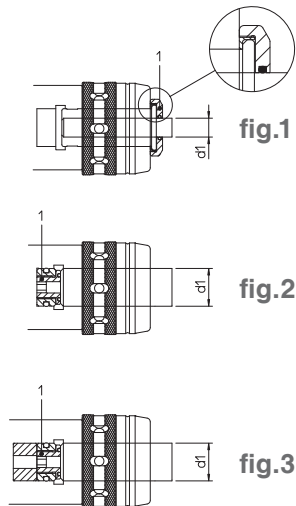
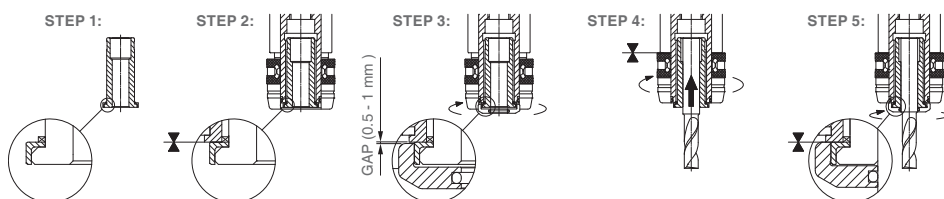


fig.	REF.	CODE1	d1
1	GH 20 MONOforce 20 HSK63 MHD'50 / DIN/BT-40-50 PSC 63 - 80	382042020061	6
		382042020081	8
		382042020101	10
		382042020121	12
		382042020141	14
		382042020161	16
2	VT 20.20 MONOforce 20 DIN/BT-40-50 HSK63-100 PSC 63-80	382042020201	20
1	GH 32 MONOforce 32 DIN/BT-40-50 / HSK63-100 MHD'63 PSC 63-80	382042032061	6
		382042032081	8
		382042032101	10
		382042032121	12
		382042032141	14
		382042032161	16
		382042032181	18
		382042032201	20
		382042032251	25
		382042032321	32
2	VT 32.32 MONOforce 32 DIN/BT-40 HSK63-100 PSC 63-80	382042032321	32
3	VT 32.32.100 MONOforce 32 DIN/BT-50	382042032322	32



- SETTING SCREW FOR INTERNAL COOLANT SUPPLY
- EINSTELLSCHRAUBE FÜR INNERE KÜHLMITTELZUFUHR
- TORNILLO REGULACIÓN PASO REFRIGERANTE
- VIS DE RÉGLAGE POUR L'ALIMENTATION DE REFROIDISSEMENT
- VITE REGOLAZIONE CON PASSAGGIO REFRIGERANTE

## FORCE VCR

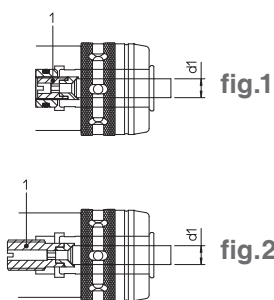
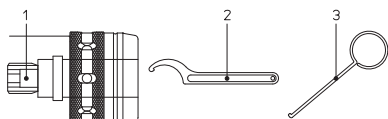


fig.	REF.	CODE 1	d1
1	VCR 20 MONOforce 20 HSK63-100 MHD'50 PSC 63-80	382041020032	3 ~ 5
		382041020062	6 ~ 12
		382041020142	14 ~ 20
1	VCR 32 MONOforce 32 HSK63-100 MHD'63 PSC 63-80	382041032033	3 ~ 5
		382041032063	6 ~ 12
		382041032143	14 ~ 20
		382041032253	25 ~ 32
2	VCR 20 MONOforce 20 DIN/BT-40-50	382041020031	3 ~ 5
		382041020061	6 ~ 12
		382041020141	14 ~ 20
2	VCR 32 MONOforce 32 DIN/BT-40	382041032031	3 ~ 5
		382041032061	6 ~ 12
		382041032141	14 ~ 20
		382041032251	25 ~ 32
2	VCR 32 MONOforce 32 DIN/BT-50	382041032032	3 ~ 5
		382041032062	6 ~ 12
		382041032142	14 ~ 20
		382041032252	25 ~ 32

## FORCE

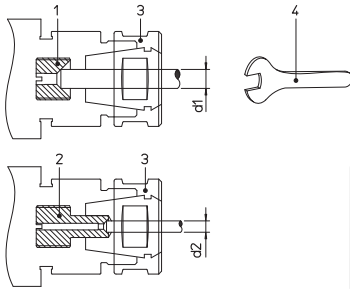


REF.	CODE 1	CODE 2	CODE 3
FORCE 12	200100191014	101500400028	201271600400
FORCE 20	200100191615	101500400050	
FORCE 32		101500400075	



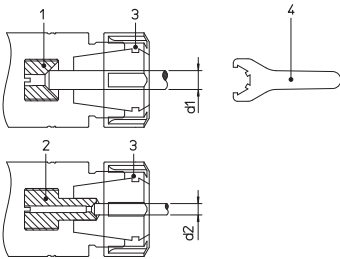
- ACCESSORIES AND SPARE PARTS
- ZUBEHÖRTEILE UND ERSATZTEILE
- ACCESORIOS Y PIEZAS DE RECAMBIO
- ACCESSOIRES ET PIÈCES ETACHÉES
- ACCESSORI E PARTI DI RICAMBIO

## TOPRUN - ER



REF.	CODE 1	d1	CODE 2	d2	CODE 3	CODE 4
ER 16	201082010001	5 ~ 10	201082010002	1 ~ 4	201041910001	201271502200
ER 25	201082018001	8 ~ 16	201082018002	2 ~ 7	201043010002	201271503400
ER 32	201082022001	8 ~ 20	201082022002	3 ~ 7	201044015001	201271504500

## MONOd' - ER



REF.	CODE 1	d1	CODE 2	d2	CODE 3	CODE 4
ER 16 M	201082010001	5 ~ 10	201082010002	1 ~ 4	100451011600	101501001600
ER 25	201082018001	8 ~ 16	201082018002	2 ~ 7	100451032500	101501002501
ER 32	201082022001	8 ~ 20	201082022002	3 ~ 7	100451033200	101501003201
ER 40	201082028001	9 ~ 26	201082028002	4 ~ 8	100451034000	101501004001

## MONOd' - WD

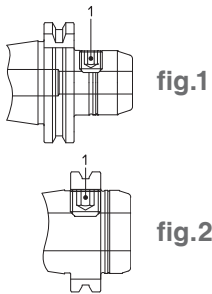
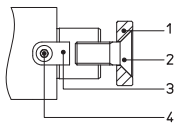


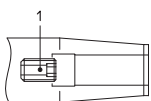
fig.	REF.	CODE 1	fig.	REF.	CODE 1
1	WD 06	200100190610	1	WD 20	200100191616
	WD 08	200100190810	2		200100191613
	WD 10	200100191010	1	WD 25	200100191820
	WD 12	200100191212	2		200100191821
	WD 14		200100191414	1	WD 32
	WD 16				
WD 18					

## MONOd' - PF



REF.	CODE 1	CODE 2	CODE 3	CODE 4
PF 16	201010085010	100101080025	201101800801	100051030008
PF 22	201010105030	100101100025	201101801002	100051040010
PF 27	201010125030	100101120030	201101801202	100051050012
PF 32	201010165020	100101160035	201101801402	100051060016

## MONOd' CT



REF.	CODE 1	REF.	CODE 1
CT 06	200100190520	CT 16	200100191221
CT 08	200100190620	CT 18	
CT 10	200100190820	CT 20	200100191620
CT 12	200100191018	CT 25	
CT 14		CT 32	

# D'ANDREA

## MCD' HSK-PSC

- INDEX
- INHALTSVERZEICHNIS
- ÍNDICE
- INDEX
- INDICE

HSK

PSC



p. 226



p. 230



p. 227



p. 231



p. 228



p. 232



p. 228



p. 232



p. 229



p. 233



p. 229



p. 233



p. 229



p. 233

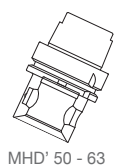


p. 234

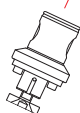


224

## Turning operations



MHD' 50 - 63



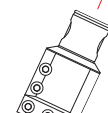
MHD' PF



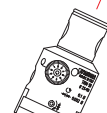
MHD' WD



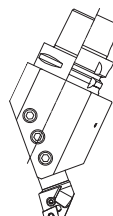
MHD' ER



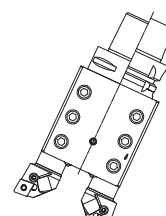
MHD' TU



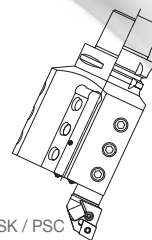
MHD' TRM



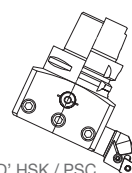
MCD' HSK / PSC  
TU 25.45 R/L



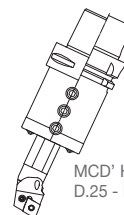
MCD' HSK / PSC  
TU 25.02 N



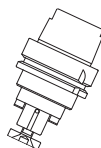
MCD' HSK / PSC  
TU 25.03



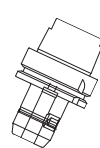
MCD' HSK / PSC  
TU 25.90



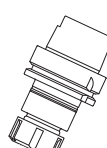
MCD' HSK / PSC  
D.25 - D.40



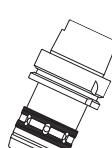
MONOd' PF



MONOd' WD

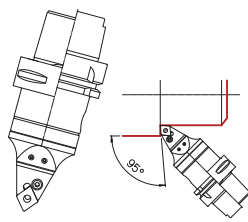


MONOd' ER

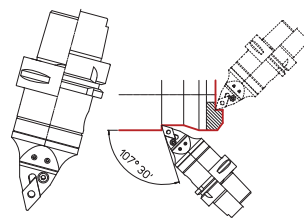


MONOforce 12 - 20 - 32

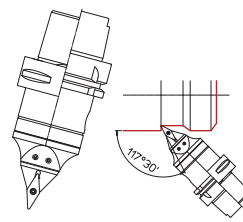




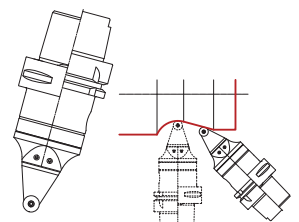
MCD' HSK / PSC  
PCMNN



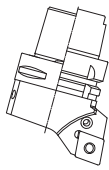
MCD' HSK / PSC  
PDNNN



MCD' HSK / PSC  
SWBN



MCD' HSK / PSC  
SRDCN



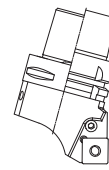
MCD' HSK / PSC  
PCLNR/L



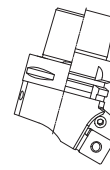
MCD' HSK / PSC  
PDJNR/L



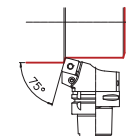
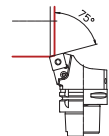
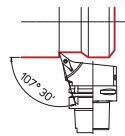
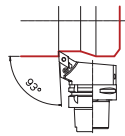
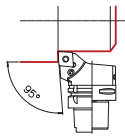
MCD' HSK / PSC  
SVHBR/L



MCD' HSK / PSC  
PSKNR/L



MCD' HSK / PSC  
PSRRN/L



- TURNING TOOLS
- DREHENWERKZEUGE
- HERRAMIENTAS DE TORNEADO
- OUTILS DE TOURNAGE
- UTENSILI DI TORNITURA

**GB** MCD' is the line of tools and tool holders for lathes, built according to ISO 26623-1 PSC and HSK-T63 standards with recommended DIN 69893-T, ICTM constructive tolerances (ISO 12164-3) for the application on spindles of MULTI-TASK machinery. The MCD' program is composed of toolholders and interchangeable bit holders. The range includes toolholders which permit the mounting of tools for internal, external, cutting and threading of the various standard programs on the market. **All Tool Holders are equipped with the passage of the coolant with standard pressure of MAX 40 BAR.**

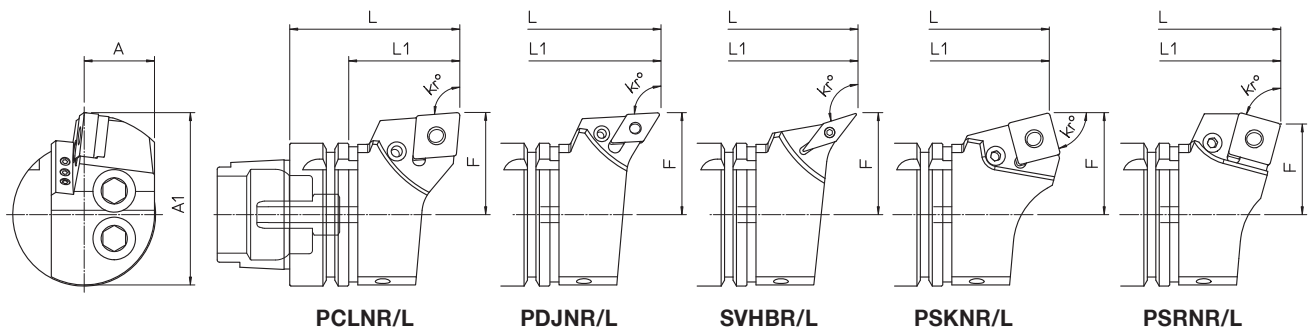
**D** MCD' ist eine Werkzeug- und Werkzeughalterlinie für Drehmaschinen nach den Normen ISO 26623-1 PSC und HSK-T63 mit DIN 69893-T, ICTM-Bautoleranzen (ISO 12164-3), die für die Anbringung auf den Spindeln von MULTI-TASK-Maschinen empfohlen werden. Das MCD' Programm wird hergestellt und besteht aus Werkzeughaltern und austauschbaren Einsatzhaltersitzen. Das Produktangebot umfasst auch Werkzeughalter, die die Montage von Werkzeugen für die Innen- und Außenbearbeitung, für Schnitt und Gewindebearbeitung der verschiedenen, auf dem Markt erhältlichen Standardprogramme ermöglichen. **Alle Werkzeughalter sind mit dem Durchgang des Kühlmediums bei Standarddruck (MAX. 40 BAR) ausgestattet.**

**E** MCD' es la línea de herramientas y portaherramientas para torno, realizados conforme a las normas ISO 26623-1 PSC y HSK-T63 con tolerancias de construcción DIN 69893-T, ICTM (ISO 12164-3) recomendadas para la aplicación en husillos de máquinas MULTI-TASK. El programa MCD' y está compuesto por portaherramientas y asientos portaplaquitas intercambiables. La gama presenta portaherramientas que permiten el montaje de herramientas para el mecanizado interno, externo, corte y roscado de los diferentes programas estándar disponibles en el mercado. **Todos los portaherramientas están preparados para permitir el paso del líquido refrigerante a un nivel de presión estándar MÁX. 40 BAR.**

**F** MCD' est la ligne d'outils et porte-outils pour le tour, réalisés selon les normes ISO 26623-1 PSC et HSK-T63 avec des tolérances de fabrication DIN 69893-T, ICTM (ISO 12164-3) recommandées pour l'application sur les broches des machines MULTI-TASK. Le programme MCD' est composé de porte-outils et logements porte-plaquette interchangeables. La gamme est complétée par le porte-outils permettant l'installation d'outils pour intérieurs, extérieurs, le découpage et le filetage des différents programmes standard existants sur le marché. **Tous les porte-outils sont prédisposés pour le passage du liquide réfrigérant à une pression standard MAX. DE 40 BARS**

**I** MCD' è la linea di utensili e portautensili da tornio, realizzati seguendo le norme ISO 26623-1 PSC e HSK-T63 con tolleranze costruttive DIN 69893-T, ICTM (ISO 12164-3) raccomandate per l'applicazione sui mandrini di macchine MULTI-TASK. Il programma MCD' è composto da portautensili e seggi porta inserto intercambiabili. La gamma è completa di portautensili che permettono il montaggio di utensili per interni, esterni, taglio e filettatura dei vari programmi standard esistenti sul mercato. **Tutti i Portautensili sono predisposti con il passaggio del liquido refrigerante con pressione standard MAX. 40 BAR**

DIN 69893  
MCD' HSK-T63



- Supplied with coolant tube
- Lieferung inklusive Kühlmittelrohr
- Completo con racor para el refrigerante
- Pourvu de raccord pour liquide d'arrosage
- Completo di raccordo per il refrigerante

- Available on request HP = High Pressure **Max 80 BAR**
- Auf Anfrage HP = High Pressure **Max 80 BAR**
- Disponible bajo pedido HP = Alta presión **Max 80 BAR**
- Disponible sur demande HP = Haute pression **Max 80 BAR**
- Fornibili a richiesta HP = Alta Pressione **Max 80 BAR**

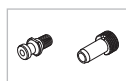
HSK-T	REF.	CODE	A	A1	F	L	L1	K <sub>r</sub> <sup>1)</sup>	γ <sup>2)</sup>	λ <sup>3)</sup>		kg				
63	MCD'HSK-T63 PCLNR 45075-19	6H06PCLNR40719N	31	76	45	75	49	95°	6°	6°	CNM..1906..	1.3				
	MCD'HSK-T63 PCLNL 45075-19	6H06PCLNL40719N						93°			DNM..1506..					
	MCD'HSK-T63 PDJNR 45075-15	6H06PDJNR40715N						73	47	107° 30'	0°		0°	VBM..1604..		
	MCD'HSK-T63 PDJNL 45075-15	6H06PDJNL40715N								75°	6°		6°	SNM..1906..		
	MCD'HSK-T63 SVHBR 45075-16	6H06SVHBR40716N														
	MCD'HSK-T63 SVHBL 45075-16	6H06SVHBL40716N						71	40	75	49		75°	6°	6°	SNM..1906..
	MCD'HSK-T63 PSKNR 45073-19	6H06PSKNR40719N														
	MCD'HSK-T63 PSKNL 45073-19	6H06PSKNL40719N														
	MCD'HSK-T63 PSRNR 40075-19	6H06PSRNR40719N														
MCD'HSK-T63 PSRNL 40075-19	6H06PSRNL40719N															

- Right hand tool holder shown. 1) Side cutting edge angle. 2) True rake angle. 3) Cutting edge inclination
- Adapter für Drehklemmhalter. 1) Einstellungswinkel. 2) Obere Freifläche. 3) Neigungswinkel
- Adaptadores porta-herramientas. 1) Ángulo de registro. 2) Ángulo de desprendimiento superior. 3) Ángulo de inclinación
- Adapteurs porte outils. 1) Angle d'enregistrement. 2) Angle de dévissage supérieure. 3) Angle d'inclinaison
- In figura portautensile destro. 1) Angolo di registrazione. 2) Angolo di spoglia superiore. 3) Angolo di inclinazione

248

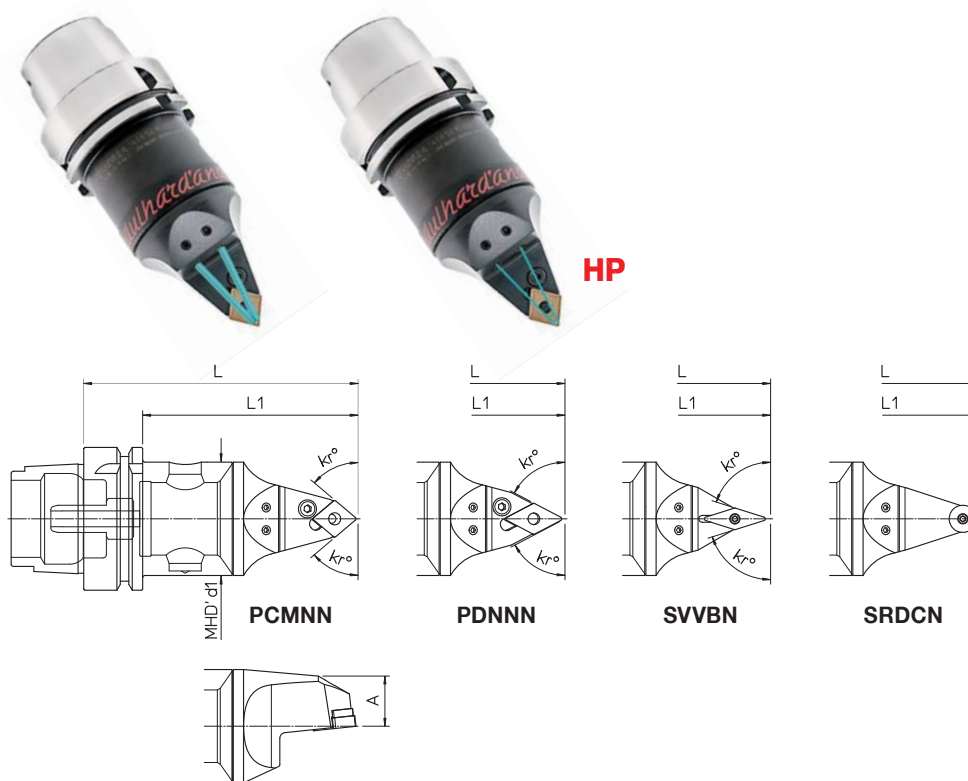
240

235-236



- TURNING TOOLS
- DREHENWERKZEUGE
- HERRAMIENTAS DE TORNEADO
- OUTILS DE TOURNAGE
- UTENSILI DI TORNITURA

DIN 69893  
MCD' HSK-T63



- Supplied with coolant tube
- Lieferung inklusive Kühlmittelrohr
- Completo con raccor para el refrigerante
- Pourvu de raccord pour liquide d'arrosage
- Completo di raccordo per il refrigerante

- Available on request HP = High Pressure **Max 80 BAR**
- Auf Anfrage HP = High Pressure **Max 80 BAR**
- Disponible bajo pedido HP = Alta presión **Max 80 BAR**
- Disponible sur demande HP = Haute pression **Max 80 BAR**
- Fornibili a richiesta HP = Alta Pressione **Max 80 BAR**

HSK-T	REF.	CODE	MHD'd1	A	L	L1	K <sub>r</sub> <sup>1)</sup>	γ <sup>2)</sup>	λ <sup>3)</sup>	⊖ ⊕ ⊙	kg
63	MCD' HSK-T63 PCMNN 00121-12	6H06PCMNN01212N	50	22	121	95	50°	6°	0°	⊖	1.4
	MCD' HSK-T63 PDNNN 00121-15	6H06PDNNN01215N					62° 30'			⊕	
	MCD' HSK-T63 SVVBN 00121-16	6H06SVVBN01216N					72° 30'	⊙			
	MCD' HSK-T63 SRDCN 00121-12	6H06SRDCN01212N					-	⊖			

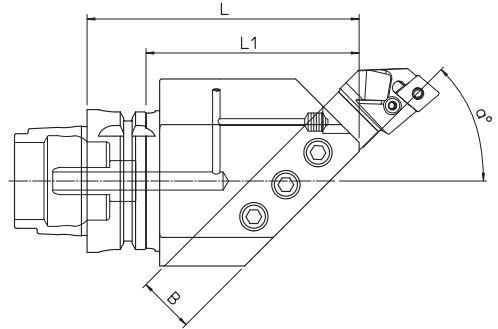
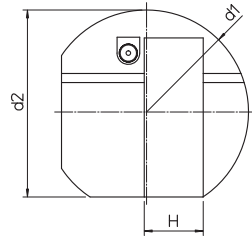
- 1) Side cutting edge angle. 2) True rake angle. 3) Cutting edge inclination
- 1) Einstellungswinkel. 2) Obere Freifläche. 3) Neigungswinkel
- 1) Ángulo de registro. 2) Ángulo de desprendimiento superior. 3) Ángulo de inclinación
- 1) Angle d'enregistrement. 2) Angle de dépouille supérieure. 3) Angle d'inclinaison
- 1) Angolo di registrazione. 2) Angolo di spoglia superiore. 3) Angolo di inclinazione

227



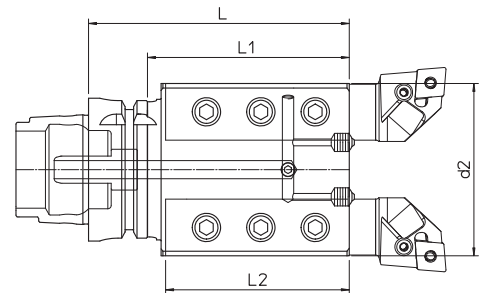
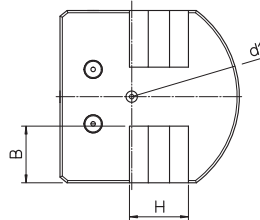
- EXTERNAL TURNING TOOL HOLDERS
- ADAPTER FÜR DREHSELN WERKZEUGHALTERUNGEN
- ADAPTADORES PORTA-HERRAMIENTAS PARA TORNEADO
- ADAPTEURS PORTE OUTILS DE TOURNAGE
- ADATTATORI PORTAUTENSILI DI TORNITURA

DIN 69893  
MCD' HSK-T63



- Right hand tool holder shown. Supplied with coolant tube. Without bit-holders and clamping wrenches. A standard application requires left hand tools with right hand adapters.
- Adapter für Drehklemmhalter. Lieferung inklusive Kühlmittelrohr. Werkzeuge und Anzugsschlüssel nicht inbegriffen. Die normale Anwendung erfordert ein linkes Werkzeug in einem rechten Adapter.
- Adaptadores porta-herramientas. Completo con racor para el refrigerante. No incluye los asientos ni las llaves de apriete. El uso normal requiere una herramienta izquiera en una adaptador derecho.
- Adapteurs porte outils. Pourvu de raccord pour liquide d'arrosage. Logements et vis de serrage excus. L'utilisation normale nécessite un outil gauche dans un adaptateur droit.
- In figura portautensile destro. Completo di raccordo per il refrigerante. Seggi e chiavi di serraggio esclusi. L'utilizzo normale richiede un utensile sinistro in un adattatore destro.

HSK-T	REF.	CODE	L	L1	d1	d2	a°	BxH	kg
63	MCD' HSK-T63 TU25.45R	71HСКА63T2545R1	120	94	90	82.5	45°	25x25	3.4
	MCD' HSK-T63 TU25.45L	71HСКА63T2545L1							



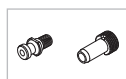
- Supplied with coolant tube. Without bit-holders and clamping wrenches
- Lieferung inklusive Kühlmittelrohr. Werkzeuge und Anzugsschlüssel nicht inbegriffen
- Completo con racor para el refrigerante. No incluye los asientos ni las llaves de apriete.
- Pourvu de raccord pour liquide d'arrosage. Logements et vis de serrage excus
- Completo di raccordo per il refrigerante. Seggi e chiavi di serraggio esclusi

HSK-T	REF.	CODE	L	L1	L2	d1	d2	BxH	kg
63	MCD' HSK-T63 TU25.02N	71HСКА63T2502N1	115	89	80	95	76	25x25	3.5

248

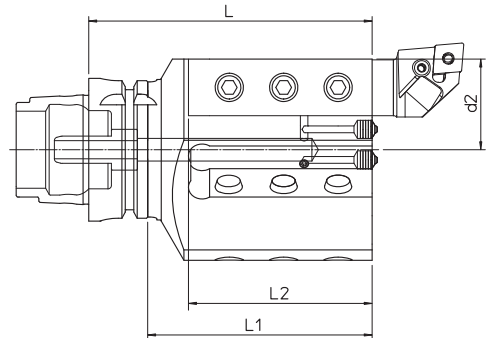
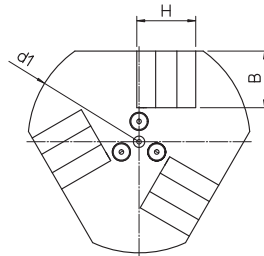
240

237



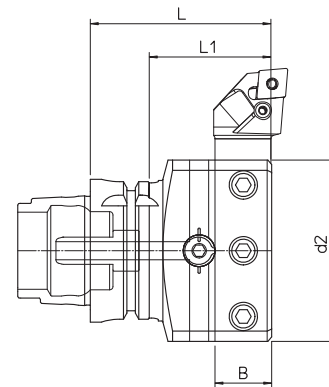
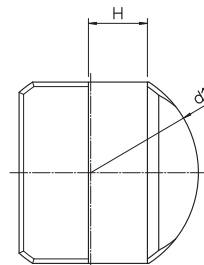
- EXTERNAL TURNING TOOL HOLDERS
- ADAPTER FÜR DRECHSELN WERKZEUGHALTERUNGEN
- ADAPTADORES PORTA-HERRAMIENTAS PARA TORNEADO
- ADAPTEURS PORTE OUTILS DE TOURNAGE
- ADATTATORI PORTAUTENSILI DI TORNITURA

DIN 69893  
MCD' HSK-T63



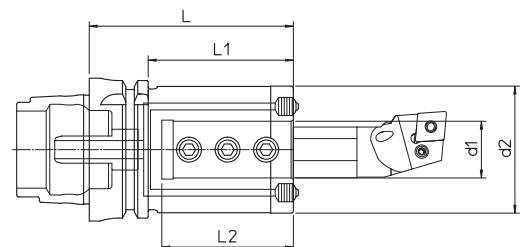
- Supplied with coolant tube. Without bit-holders and clamping wrenches
- Lieferung inklusive Kühlmittelrohr. Werkzeuge und Anzugsschlüssel nicht inbegriffen
- Completo con racor para el refrigerante. No incluye los asientos ni las llaves de apriete.
- Pourvu de raccord pour liquide d'arrosage. Logements et vis de serrage exclus
- Completo di raccordo per il refrigerante. Seggi e chiavi di serraggio esclusi

HSK-T	REF.	CODE	L	L1	L2	d1	d2	BxH	kg
63	MCD' HSK-T63 TU25.03R	71HСКА63T2503R1	125	99	80	98	40	25x25	4
	MCD' HSK-T63 TU25.03L	71HСКА63T2503L1							



- Supplied with coolant tube. Without bit-holders and clamping wrenches
- Lieferung inklusive Kühlmittelrohr. Werkzeuge und Anzugsschlüssel nicht inbegriffen
- Completo con racor para el refrigerante. No incluye los asientos ni las llaves de apriete.
- Pourvu de raccord pour liquide d'arrosage. Logements et vis de serrage exclus
- Completo di raccordo per il refrigerante. Seggi e chiavi di serraggio esclusi

HSK-T	REF.	CODE	L	L1	d1	d2	BxH	kg
63	MCD' HSK-T63 TU25.90	71HСКА63T259001	80	54	95	80	25x25	5.1



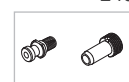
- Supplied with coolant tube. Without bit-holders and clamping wrenches. **Reduction bushes on request.**
- Lieferung inklusive Kühlmittelrohr. Werkzeuge und Anzugsschlüssel nicht inbegriffen. **Einsatzhülse auf Anfrage.**
- Completo con racor para el refrigerante. No incluye los asientos ni las llaves de apriete. **Casquillos reductores bajo pedido.**
- Pourvu de raccord pour liquide d'arrosage. Logements et vis de serrage exclus. **Douilles de réduction sur demande.**
- Completo di raccordo per il refrigerante. Seggi e chiavi di serraggio esclusi. **Bussole di riduzione a richiesta.**

HSK-T	REF.	CODE	d1 <sup>H7</sup>	d2	L	L1	L2	kg
63	MCD' HSK-T63 D.25x90	71HСКА63D250901	25	56	90	64	58	1.6
	MCD' HSK-T63 D.40x135	71HСКА63D401301	40	80	135	109	85	3.9

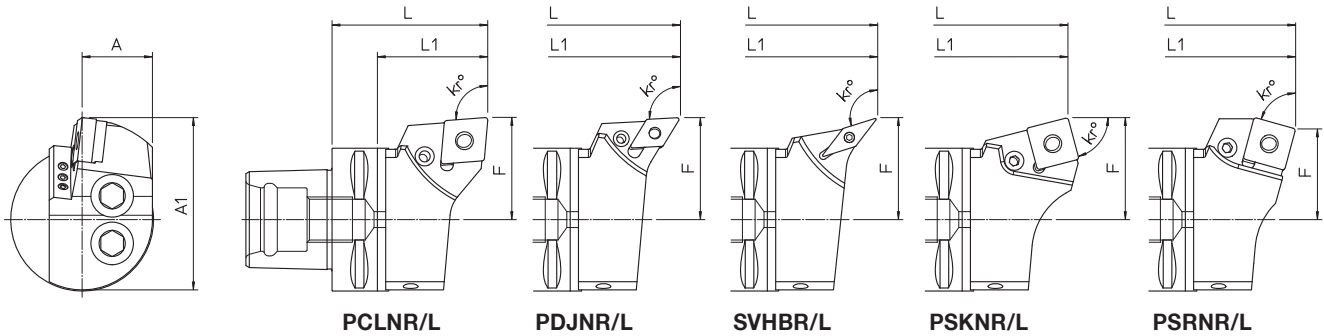
237

240

248



ISO 26623-1  
MCD' PSC



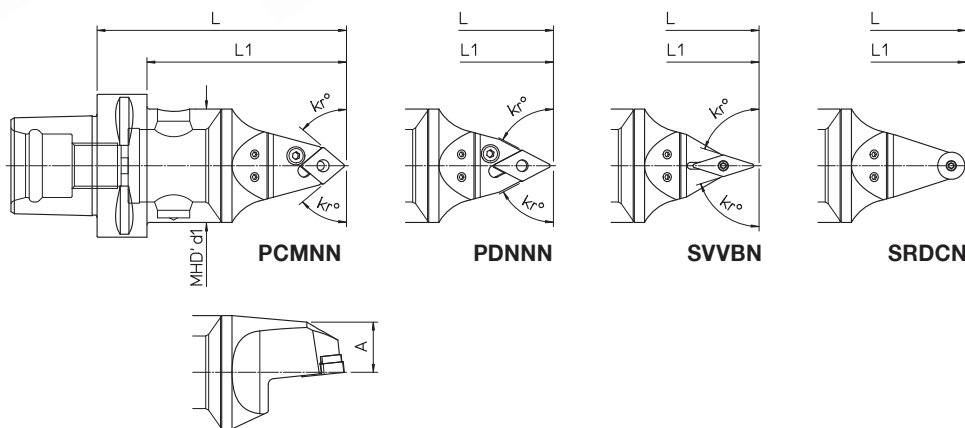
- Available on request HP = High Pressure **Max 80 BAR**
- Auf Anfrage HP = High Pressure **Max 80 BAR**
- Disponible bajo pedido HP = Alta presión **Max 80 BAR**
- Disponible sur demande HP = Haute pression **Max 80 BAR**
- Fornibili a richiesta HP = Alta Pressione **Max 80 BAR**

PSC	REF.	CODE	A	A <sub>1</sub>	F	L	L <sub>1</sub>	K <sub>r</sub> <sup>1)</sup>	γ <sup>2)</sup>	λ <sup>3)</sup>		kg				
40	MCD' PSC 40 PCLNR/L 27050-12	6P04PCLNR/L20512N	19.5	47	27	50	30	95°	6°	6°	CNM..1204..	0.5				
	MCD' PSC 40 PDJNR/L 27055-15	6P04PDJNR/L20515N						93°			DNM..1506..					
	MCD' PSC 40 PSKNR/L 27050-12	6P04PSKNR/L20512N						75°			SNM..1204..					
	MCD' PSC 40 PSRNR/L 22050-12	6P04PSRNR/L20512N						50			30		75°	SNM..1204..		
50	MCD' PSC 50 PCLNR/L 35060-12	6P05PCLNR/L30612N	24.5	60	35	60	40	95°	6°	6°	CNM..1204..	0.8				
	MCD' PSC 50 PDJNR/L 35060-15	6P05PDJNR/L30615N						93°			DNM..1508..					
	MCD' PSC 50 PSKNR/L 35060-12	6P05PSKNR/L30612N						75°			SNM..1204..					
	MCD' PSC 50 PSRNR/L 27060-12	6P05PSRNR/L20612N						52			27		75°	SNM..1204..		
63	MCD' PSC 63 PCLNR/L 45065-19	6P06PCLNR/L40619N	31	76	45	65	45	95°	6°	6°	CNM..1906..	1.3				
	MCD' PSC 63 PDJNR/L 45065-15	6P06PDJNR/L40615N						93°			DNM..1506..					
	MCD' PSC 63 SVHBR/L 45065-16	6P06SVHBR/L40616N						107.5°			0°		0°	VBM..1604..		
	MCD' PSC 63 PSKNR/L 45065-19	6P06PSKNR/L40619N						63			43		75°	6°	6°	SNM..1906..
	MCD' PSC 63 PSRNR/L 40065-19	6P06PSRNR/L40619N						71			40		65	45	75°	6°
80	MCD' PSC 80 PCLNR/L 55080-19	6P08PCLNR/L50819N	39.5	95	55	80	50	95°	6°	6°	CNM..1906..	2.8				
	MCD' PSC 80 PDJNR/L 55080-15	6P08PDJNR/L50815N						93°			DNM..1506..					
	MCD' PSC 80 SVHBR/L 55080-16	6P08SVHBR/L50816N						107.5°			0°		0°	VBM..1604..		
	MCD' PSC 80 PSKNR/L 55080-19	6P08PSKNR/L50819N						78			48		75°	6°	6°	SNM..1906..
	MCD' PSC 80 PSRNR/L 45080-19	6P08PSRNR/L40819N						85			45		80	50	75°	6°

- Right hand tool holder shown. 1) Side cutting edge angle. 2) True rake angle. 3) Cutting edge inclination
- Adapter für Drehklemmhalter. 1) Einstellungswinkel. 2) Obere Freifläche. 3) Neigungswinkel
- Adaptadores porta-herramientas. 1) Ángulo de registro. 2) Ángulo de desprendimiento superior. 3) Ángulo de inclinación
- Adapteurs porte outils. 1) Angle d'enregistrement. 2) Angle de dépouille supérieure. 3) Angle d'inclinaison
- In figura portautensile destro. 1) Angolo di registrazione. 2) Angolo di spoglia superiore. 3) Angolo di inclinazione

- TURNING TOOLS
- DREHENWERKZEUGE
- HERRAMIENTAS DE TORNEADO
- OUTILS DE TOURNAGE
- UTENSILI DI TORNITURA

ISO 26623-1  
MCD' PSC



- Available on request HP = High Pressure **Max 80 BAR**
- Auf Anfrage HP = High Pressure **Max 80 BAR**
- Disponible bajo pedido HP = Alta presión **Max 80 BAR**
- Disponible sur demande HP = Haute pression **Max 80 BAR**
- Fornibili a richiesta HP = Alta Pressione **Max 80 BAR**

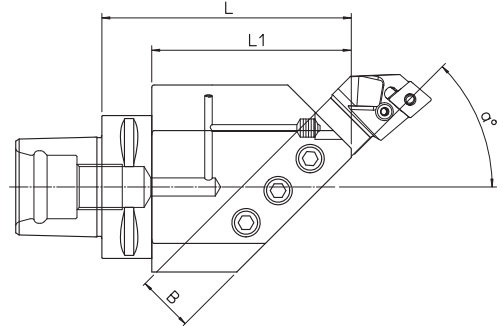
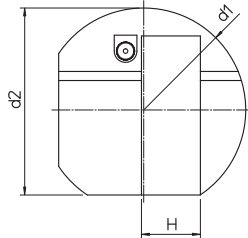
PSC	REF.	CODE	MHD'd <sub>1</sub>	A	L	L <sub>1</sub>	K <sub>r</sub> <sup>1)</sup>	γ <sup>2)</sup>	λ <sup>3)</sup>		kg
40	MCD' PSC 40 PCMNN 00090-12	6P04PCMNN00912N	40	22.5	90	70	50	6°	0°	CNM..1204..	0.7
	MCD' PSC 40 PDNNN 00090-15	6P04PDNNN00915N					62.5			DNM..1506..	
	MCD' PSC 40 SVVBN 00090-16	6P04SVVBN00916N					72.5	VBM..1604..			
	MCD' PSC 40 SRDCN 00090-10	6P04SRDCN00910N					-	RCM..10T3..			
50	MCD' PSC 50 PCMNN 00110-12	6P05PCMNN01112N	50	22.1	110	88	50	6°	0°	CNM..1204..	1.2
	MCD' PSC 50 PDNNN 00110-15	6P05PDNNN01115N					62.5			DNM..1506..	
	MCD' PSC 50 SVVBN 00110-16	6P05SVVBN01116N					72.5	VBM..1604..			
	MCD' PSC 50 SRDCN 00110-12	6P05SRDCN01112N					-	RCM..1204..			
63	MCD' PSC 63 PCMNN 00110-12	6P06PCMNN01112N	63	28.5	140	110	50	6°	0°	CNM..1204..	1.6
	MCD' PSC 63 PDNNN 00110-15	6P06PDNNN01115N					62.5			DNM..1506..	
	MCD' PSC 63 SVVBN 00110-16	6P06SVVBN01116N					72.5	VBM..1604..			
	MCD' PSC 63 SRDCN 00110-12	6P06SRDCN01112N					-	RCM..1204..			
80	MCD' PSC 80 PCMNN 00140-12	6P08PCMNN01412N	80	28.5	140	110	50	6°	0°	CNM..1204..	3.3
	MCD' PSC 80 PDNNN 00140-15	6P08PDNNN01415N					62.5			DNM..1506..	
	MCD' PSC 80 SVVBN 00140-16	6P08SVVBN01416N					72.5	VBM..1604..			
	MCD' PSC 80 SRDCN 00140-16	6P08SRDCN01416N					-	RCM..1606..			

- 1) Side cutting edge angle. 2) True rake angle. 3) Cutting edge inclination
- 1) Einstellungswinkel. 2) Obere Freifläche. 3) Neigungswinkel
- 1) Ángulo de registro. 2) Ángulo de desprendimiento superior. 3) Ángulo de inclinación
- 1) Angle d'enregistrement. 2) Angle de dépouille supérieure. 3) Angle d'inclinaison
- 1) Angolo di registrazione. 2) Angolo di spoglia superiore. 3) Angolo di inclinazione



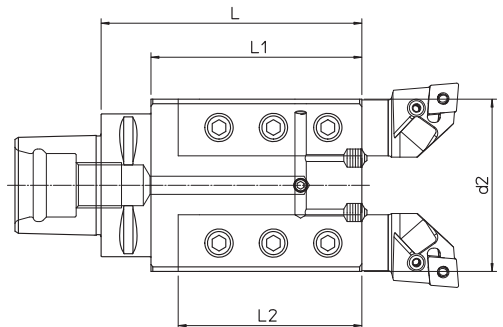
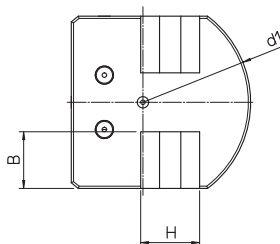
- EXTERNAL TURNING TOOL HOLDERS
- ADAPTER FÜR DREHSELN WERKZEUGHALTERUNGEN
- ADAPTADORES PORTA-HERRAMIENTAS PARA TORNEADO
- ADAPTEURS PORTE OUTILS DE TOURNAGE
- ADATTATORI PORTAUTENSILI DI TORNITURA

ISO 26623-1  
MCD' PSC



- Right hand tool holder shown. Without bit-holders and clamping wrenches. A standard application requires left hand tools with right hand adapters.
- Adapter für Drehklemmhalter. Werkzeuge und Anzugsschlüssel nicht inbegriffen. Die normale Anwendung erfordert ein linkes Werkzeug in einem rechten Adapter.
- Adaptadores porta-herramientas. No incluye los asientos ni las llaves de apriete. El uso normal requiere una herramienta izquierda en una adaptador derecho.
- Adapteurs porte outils. Logements et vis de serrage exlcus. L'utilisation normale nécessite un outil gauche dans un adaptateur droit.
- In figura portautensile destro. Seggi e chiavi di serraggio esclusi. L'utilizzo normale richiede un utensile sinistro in un adattatore destro.

PSC	REF.	CODE	L	L <sub>1</sub>	d <sub>1</sub>	d <sub>2</sub>	a°	BxH	kg
50	MCD' PSC 50 TU20.45R/L	71PSC050T2045R/L1	90	70	72	65	45°	20x20	1.8
63	MCD' PSC 63 TU25.45R/L	71PSC063T2545R/L1	110	88	90	82.5		25x25	3.5
80	MCD' PSC 80 TU32.45R/L	71PSC080T3245R/L1	135	105	115	98.5		32x32	6.4



- Without bit-holders and clamping wrenches
- Werkzeuge und Anzugsschlüssel nicht inbegriffen
- No incluye los asientos ni las llaves de apriete.
- Logements et vis de serrage exlcus
- Seggi e chiavi di serraggio esclusi

PSC	REF.	CODE	L	L <sub>1</sub>	L <sub>2</sub>	d <sub>1</sub>	d <sub>2</sub>	BxH	kg
50	MCD' PSC 50 TU20.02	71PSC050T200201	100	80	64	80	63	20x20	2.5
63	MCD' PSC 63 TU25.02	71PSC063T250201	115	93	80	95	76	25x25	4
80	MCD' PSC 80 TU32.02	71PSC080T320201	125	95		115	86	32x32	6.2

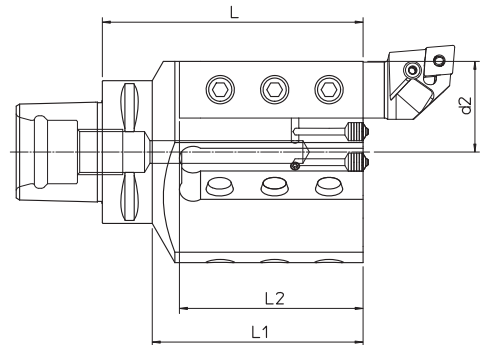
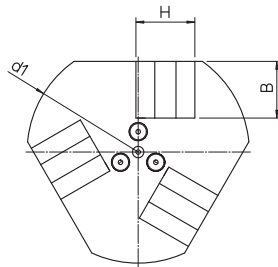
252

237



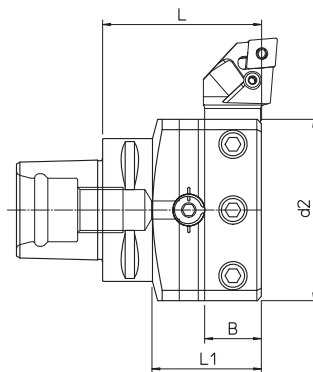
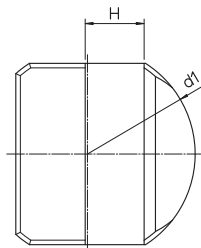
- **EXTERNAL TURNING TOOL HOLDERS**
- **ADAPTER FÜR DRECHSELN WERKZEUGHALTERUNGEN**
- **ADAPTADORES PORTA-HERRAMIENTAS PARA TORNEADO**
- **ADAPTEURS PORTE OUTILS DE TOURNAGE**
- **ADATTATORI PORTAUTENSILI DI TORNITURA**

ISO 26623-1  
MCD' PSC



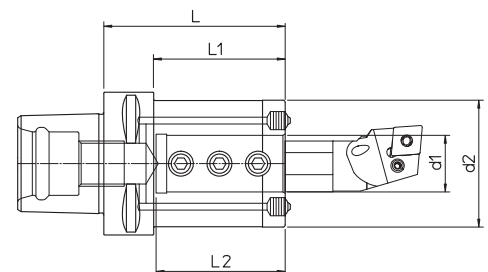
- Without bit-holders and clamping wrenches
- Werkzeuge und Anzugsschlüssel nicht inbegriffen
- No incluye los asientos ni las llaves de apriete.
- Logements et vis de serrage excus
- Seggi e chiavi di serraggio esclusi

PSC	REF.	CODE	L	L1	L2	d1	d2	BxH	kg
63	MCD' PSC 63 TU25.03R	71PSC063T2503R1	115	93	80	98	40	25x25	4
	MCD' PSC 63 TU25.03L	71PSC063T2503L1							



- Without bit-holders and clamping wrenches
- Werkzeuge und Anzugsschlüssel nicht inbegriffen
- No incluye los asientos ni las llaves de apriete.
- Logements et vis de serrage excus
- Seggi e chiavi di serraggio esclusi

PSC	REF.	CODE	L	L1	d1	d2	BxH	kg
50	MCD' PSC 50 TU20.90	71PSC050T209001	60	40	80	64	20x20	1.4
63	MCD' PSC 63 TU25.90	71PSC063T259001	70	48	95	80	25x25	2.6
80	MCD' PSC 80 TU32.90	71PSC080T329001	85	55	133	105	32x32	5.2



- Without bit-holders and clamping wrenches. **Reduction bushes on request.**
- Werkzeuge und Anzugsschlüssel nicht inbegriffen. **Einsatzhülse auf Anfrage.**
- No incluye los asientos ni las llaves de apriete. **Casquillos reductores bajo pedido.**
- Logements et vis de serrage excus. **Douilles de réduction sur demande.**
- Seggi e chiavi di serraggio esclusi. **Bussole di riduzione a richiesta.**

PSC	REF.	CODE	d1H7	d2	L	L1	L2	kg
50	MCD' PSC 50 D.25x80	71PSC050D250801	25	56	80	60	58	1.4
63	MCD' PSC 63 D.25x80	71PSC063D250801				58		1.7
		MCD' PSC 63 D.40x125	71PSC063D401201	40	80	125	103	85
80	MCD' PSC 80 D.25x85	71PSC080D250801	25	56	85	55	58	2.6
	MCD' PSC 80 D.40x125	71PSC080D401201	40	80	125	95	85	4.6

237

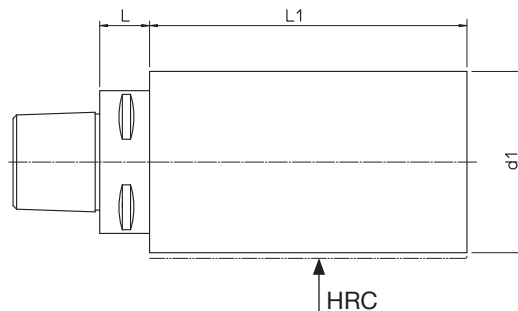
252





- SEMIFINISHED CHUCK HOLDERS
- WERKZEUGAUFNAHMERÖHLING
- ADAPTADORES SEMIELABORADOS
- ADAPTATEURS SEMI-FINIS
- ADATTATORI SEMILAVORATI

ISO 26623-1  
PSC-NS-H28-42



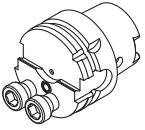
PSC	REF.	CODE	$d_1$	L	L <sub>1</sub>	kg	HRC
40	PSC 40 - NS 50.160/140 H.28	71PSC040Z205014	50	20	140	2.4	28
	PSC 40 - NS 63.160/140 H.28	71PSC040Z206314	63			3.6	
	PSC 40 - NS 80.160/140 H.28	71PSC040Z208014	80			5.7	
50	PSC 50 - NS 63.160/140 H.28	71PSC050Z206314	63			3.8	
	PSC 50 - NS 80.160/140 H.28	71PSC050Z208014	80			10.2	
	PSC 50 - NS 100.180/160 H.28	71PSC050Z210016	100			160	
63	PSC 63 - NS 80.162/140 H.28	71PSC063Z208014	80	22	140	6.2	
	PSC 63 - NS 100.182/160 H.28	71PSC063Z210016	100		160	10.4	
	PSC 63 - NS 120.202/180 H.28	71PSC063Z212018	120		180	17	
80	PSC 80 - NS 100.190/160 H.28	71PSC080Z210016	100	30	160	11.5	
	PSC 80 - NS 140.210/180 H.28	71PSC080Z214018	140		180	23.4	

PSC	REF.	CODE	$d_1$	L	L <sub>1</sub>	kg	HRC
40	PSC 40 - NS 50.160/140 H.42	71PSC040Z405014	50	20	140	2.4	42
	PSC 40 - NS 63.160/140 H.42	71PSC040Z406314	63			3.6	
	PSC 40 - NS 80.160/140 H.42	71PSC040Z408014	80			5.7	
50	PSC 50 - NS 63.160/140 H.42	71PSC050Z406314	63			3.8	
	PSC 50 - NS 80.160/140 H.42	71PSC050Z408014	80			10.2	
	PSC 50 - NS 100.180/160 H.42	71PSC050Z410016	100			160	
63	PSC 63 - NS 80.162/140 H.42	71PSC063Z408014	80	22	140	6.2	
	PSC 63 - NS 100.182/160 H.42	71PSC063Z410016	100		160	10.4	
	PSC 63 - NS 120.202/180 H.42	71PSC063Z412018	120		180	17	
80	PSC 80 - NS 100.190/160 H.42	71PSC080Z410016	100	30	160	11.5	
	PSC 80 - NS 140.210/180 H.42	71PSC080Z414018	140		180	23.4	

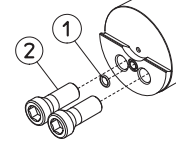


- ACCESSORIES AND SPARE PARTS
- ZUBEHÖRTEILE UND ERSATZTEILE
- ACCESORIOS Y PIEZAS DE RECAMBIO
- ACCESSOIRES ET PIÈCES DETACHÉES
- ACCESSORI E PARTI DI RICAMBIO

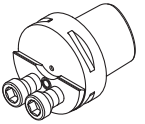
## MCD' HSK



REF. MCD'	CODE
HSK-T63 F30 RL	71HSKA63F030RL1



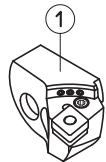
## MCD' PSC



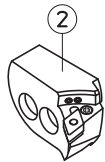
REF. MCD'	CODE
PSC 40 F20 RL	71PSC040F020RL1
PSC 50 F20 RL	71PSC050F020RL1
PSC 63 F20 RL	71PSC063F020RL1
PSC 80 F30 RL	71PSC080F030RL1

REF. MCD'	CODE 1	CODE 2
PSC 40	101254004515	200100170620
PSC 50		200100170820
HSK-T63 / PSC 63	101254005515	200100171225
PSC 80		200100171631

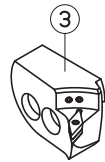
## MCD' HSK / PSC



PCLNR/L



PDJNR/L



SVHBR/L

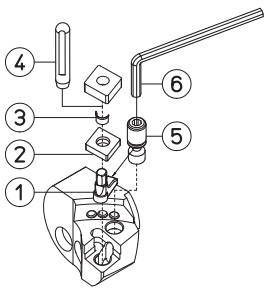


PSKNR/L

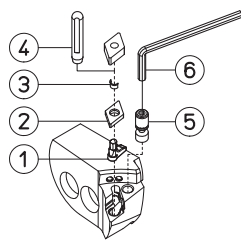


PSRNR/L

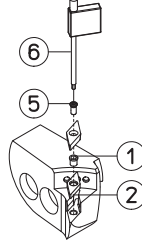
REF.	CODE 1	CODE 2	CODE 3	CODE 4	CODE 5
MCD' 40	7504PCLNR/L20312N	7504PDJNR/L20315N		7504PSKNR/L20312N	7504PSRNR/L20312N
MCD' 50	7505PCLNR/L30412N	7505PDJNR/L30415N		7505PSKNR/L30412N	7505PSRNR/L20412N
MCD' 63	7506PCLNR/L40419N	7506PDJNR/L40415N	7506SVHBR/L40416N	7506PSKNR/L40419N	7506PSRNR/L40419N
MCD' 80	7508PCLNR/L50519N	7508PDJNR/L50515N	7508SVHBR/L50516N	7508PSKNR/L50519N	7508PSRNR/L40519N



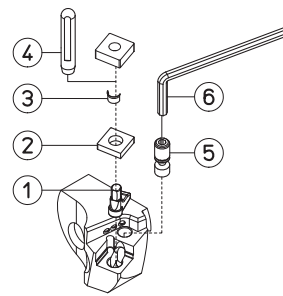
PCLNR/L



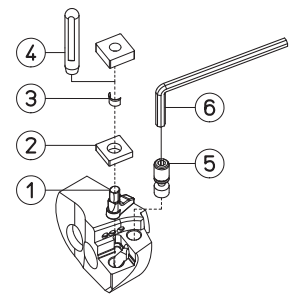
PDJNR/L



SVHBR/L

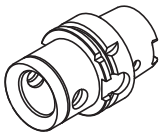


PSKNR/L



PSRNR/L

	REF.	CODE 1	CODE 2	CODE 3	CODE 4	CODE 5	CODE 6
□	PCLNR/L ... - 12	491110000002	492030003012	100655065060	101501307100	494310080230	101500100300
	PCLNR/L ... - 19	491111190600	492031190600	100655095112	101501301408	494311190600	101500100400
◊	PDJNR/L ... - 15	491110000003	492030003015	100655065060	101501307100	494310080260	101500100400
	SVHBR/L ... - 16	492010000508	492030003016	-	-	494210035070	101500901500
◻	PSKNR/L ... - 12	491110000002	492035120400	100655065060	101501307100	494310080230	101500100300
	PSKNR/L ... - 19	491111190600	492035190600	100655095112	101501301408	494311190600	101500100400
◻	PSRNR/L ... - 12	491110000002	492035120400	100655065060	101501307100	494310080230	101500100300
	PSRNR/L ... - 19	491111190600	492035190600	100655095112	101501301408	494311190600	101500100400

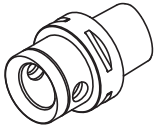


### MCD' HSK

HSK-A	REF.	CODE
63	HSK-A63 MHD'50.66	416501506320

- Complete range of cones on page 17 • Komplette Konusreihe auf Seite 17 • Gama completa de los conos en la pág. 17
- Gamme complète des cônes à la page 17 • Gamma completa dei coni a pag. 17

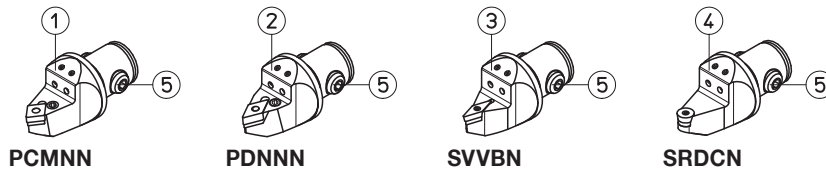
### MCD' PSC



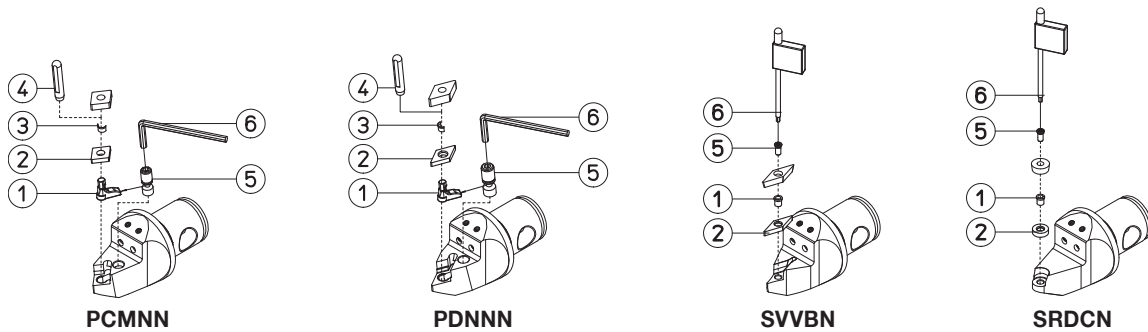
PSC	REF.	CODE
40	PSC 40 - MHD' 40.45	416402604004
50	PSC 50 - MHD' 50.55	416502605005
63	PSC 63 - MHD' 50.55	416502606305
80	PSC 80 - MHD' 63.70	416632608007

- Complete range of cones on page 19 • Komplette Konusreihe auf Seite 19 • Gama completa de los conos en la pág. 19
- Gamme complète des cônes à la page 19 • Gamma completa dei coni a pag. 19

### MCD' HSK / PSC

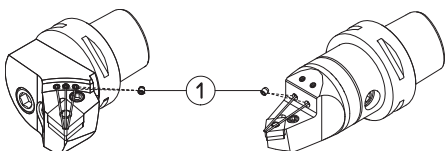


REF.	CODE 1	CODE 2	CODE 3	CODE 4	CODE 5
MCD' MHD' 40	657540001120	657540002150	657540003160	657540004100	381725001401
MCD' MHD' 50	657550001120	657550002150	657550003160	657550004120	381725001501
MCD' MHD' 63	657563001120	657563002150	657563003160	657563004160	381725001002



REF	CODE 1	CODE 2	CODE 3	CODE 4	CODE 5	CODE 6
PCMNN ... - 12	491110000002	492030003012	100655065060	101501307100	494310080230	101500100300
PDNNN ... - 15	491110000003	492030003015	100655065060	101501307100	494310080260	101500100400
SVVBN ... - 16	492010000508	492030003016	-	-	494210035070	101500901500
SRDCN ... - 10	492010000508	492034100300	-	-	494210035070	101500901500
SRDCN ... - 12	492010000508	492030003013	-	-	494210035070	101500901500
SRDCN ... - 16	492014160600	492034160600	-	-	494214160600	101500902000

### MCD' HSK / PSC HP

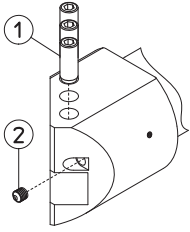


REF.	CODE 1
MCD' HSK / PSC HP	100580110450



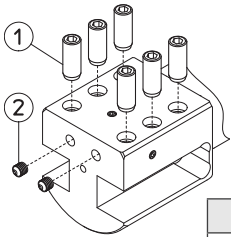
- ACCESSORIES AND SPARE PARTS
- ZUBEHÖRTEILE UND ERSATZTEILE
- ACCESORIOS Y PIEZAS DE RECAMBIO
- ACCESSOIRES ET PIÈCES DETACHÉES
- ACCESSORI E PARTI DI RICAMBIO

MCD' HSK / PSC



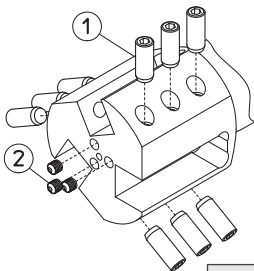
REF.	CODE 1	CODE 2
MCD' HSK-T63 TU25.45R/L	100231120025	100585010800
MCD' PSC 50 TU20.45R/L		
MCD' PSC 63 TU25.45R/L		
MCD' PSC 80 TU32.45R/L		

MCD' HSK / PSC



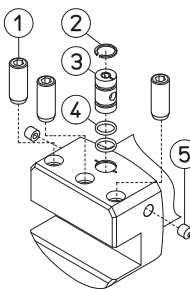
REF.	CODE 1	CODE 2
MCD' HSK-T63 TU25.02	100231120025	100585010800
MCD' PSC 50 TU20.02		
MCD' PSC 63 TU25.02		
MCD' PSC 80 TU32.02		

MCD' HSK / PSC



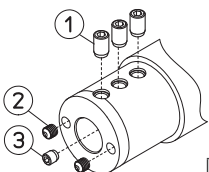
REF.	CODE 1	CODE 2
MCD' HSK-T63 TU25.03R/L	100231120025	100585010800
MCD' PSC 63 TU25.03R/L		

MCD' HSK / PSC



REF.	CODE 1	CODE 2	CODE 3	CODE 4	CODE 5
MCD' PSC 50 TU20.90	100231120025	100900301400	201462501400	101251002043	100580610180
MCD' PSC 63 TU25.90					
MCD' HSK-T63 TU25.90					
MCD' PSC 80 TU32.90					

MCD' HSK / PSC



REF.	CODE 1	CODE 2	CODE 3
MCD' PSC 50 D.25x80	100231100016	100585010800	-
MCD' HSK-T63 / PSC 63 D.25x80	100231120020		100231080008
MCD' HSK-T63 / PSC 63 D.40x125	100231100016		-
MCD' PSC 80 D.25x85	100231120020		100231080008
MCD' PSC 80 D.40x125	100231120020		100231080008

# D'ANDREA ACCESSORIES

- ACCESSORIES
- ZUBEHÖRTEILE
- ACCESORIOS
- ACCESSOIRES
- ACCESSORI

238

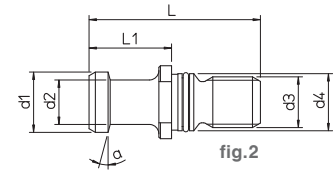
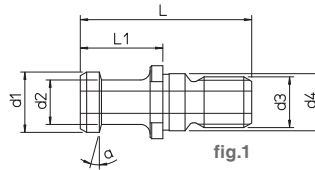






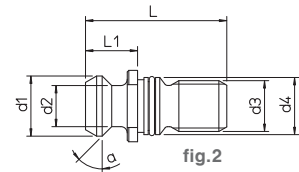
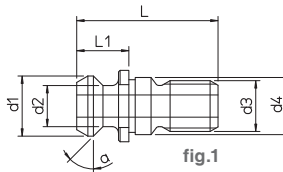
- ACCESSORIES
- ZUBEHÖRTEILE
- ACCESORIOS
- ACCESSOIRES
- ACCESSORI

## ISO 7388/2 A - DIN 69872



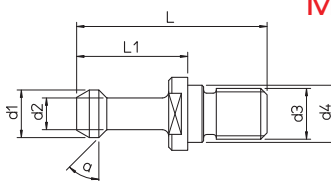
REF.	CODE	ISO	d1	d2	d3	d4	L	L1	a	fig.
ISO 7388/2 A DIN 69872	201430250401	40	19	14	M16	17	54	26	15°	1
	201430250451	45	23	17	M20	21	65	30		
	201430250501	50	28	21	M24	25	74	34		
	201430250400	40	19	14	M16	17	54	26		2
	201430250500	50	28	21	M24	25	74	34		
201430250600	60	40	30	M30	32	90	40			

## ISO 7388/2 B - ANSI B.5 50



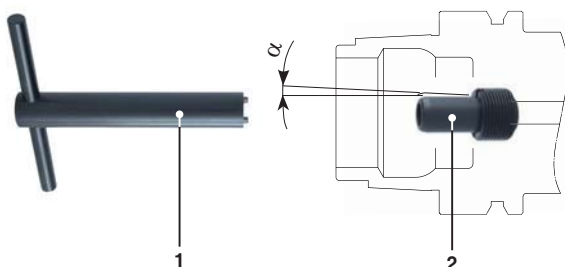
REF.	CODE	ISO	d1	d2	d3	d4	L	L1	a	fig.
ISO 7388/2 B ANSI B.5 50	201430251401	40	18.95	12.95	M16	17	44.50	16.40	45°	1
	201430251451	45	24.05	16.30	M20	21	56	20.95		
	201430251501	50	29.10	19.60	M24	25	65.50	25.55		
	201430251400	40	18.95	12.95	M16	17	44.50	16.40		2
	201430251500	50	29.10	19.60	M24	25	65.50	25.55		

## MAS 403 BT - 30° - 45°



REF.	CODE	ISO	d1	d2	d3	d4	L	L1	a
MAS 403 BT 30°	201430252301	30	11	7	M12	12.5	43	23	30°
	201430252401	40	15	10	M16	17	60	35	
	201430252451	45	19	14	M20	21	70	40	
	201430252501	50	23	17	M24	25	85	45	
	201430252601	60	32	24	M30	31	115	65	
MAS 403 BT 45°	201430252302	30	11	7	M12	12.5	43	23	45°
	201430252402	40	15	10	M16	17	60	35	
	201430252452	45	19	14	M20	21	70	40	
	201430252502	50	23	17	M24	25	85	45	
	201430252602	60	32	24	M30	31	115	65	

## HSK



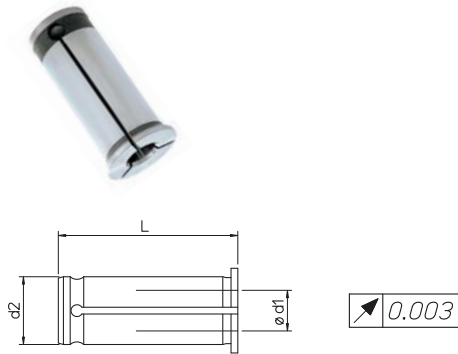
REF.	CODE	α	CODE
HSK-A40	101501101000	± 1°	382019008001
HSK-A50	101501101400		382019010001
HSK-A63 / HSK-T63	101501101600		382019012001
HSK-A80	101501101800		382019014001
HSK-A100	101501102200		382019016001



- ACCESSORIES
- ZUBEHÖRTEILE
- ACCESORIOS
- ACCESSOIRES
- ACCESSORI

- BUSHES FOR ULTRA-TIGHT SPINDLE
- SPANNHÜLSEN FÜR AUFNAHMEN MIT HOHER KLEMMKRAFT
- PINZAS PARA MANDRINO DE GRAN APRIETE
- DOUILLES POUR MANDRIN À SERRAGE FORT
- BUSSOLE PER MANDRINO A FORTE SERRAGGIO

RC



FORCE (d <sub>2</sub> )	REF.	CODE	d <sub>1</sub>	L
12	RC 12.03	497080012030	3	44
	RC 12.04	497080012040	4	
	RC 12.06	497080012060	6	
	RC 12.08	497080012080	8	
	RC 12.10	497080012100	10	
20	RC 20.03	497080020030	3	50
	RC 20.04	497080020040	4	
	RC 20.05	497080020050	5	
	RC 20.06	497080020060	6	
	RC 20.08	497080020080	8	
	RC 20.10	497080020100	10	
	RC 20.12	497080020120	12	
	RC 20.14	497080020140	14	
32	RC 32.03	497080032030	3	63
	RC 32.04	497080032040	4	
	RC 32.05	497080032050	5	
	RC 32.06	497080032060	6	
	RC 32.08	497080032080	8	
	RC 32.10	497080032100	10	
	RC 32.12	497080032120	12	
	RC 32.14	497080032140	14	
	RC 32.16	497080032160	16	
	RC 32.18	497080032180	18	
	RC 32.20	497080032200	20	
RC 32.25	497080032250	25		

- RC SEALED bushes supplied upon request
- Auf Anfrage RC Dichtbuchsen lieferbar
- Suministrables bajo pedido casquillos RC ESTANCOS
- Disponibles sur demande douilles RC étanches
- Fornibili su richiesta bussole RC a TENUTA

- REDUCTIONS
- REDUZIERUNGEN
- REDUCCIONES
- RÉDUCTIONS
- RIDUZIONE



D

REF.	CODE	L	Ø d	fig.
D04.16	200560116040	23	4	1
D08.16	200560116082	22	8	2
D10.16	200560116100	23	10	1
D12.16	200560116120		12	



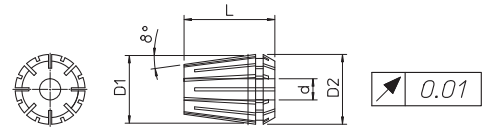
- 1 B3.06
- 1 B3.08
- 1 B3.11
- 1 B3.16 5 TPGX 090202L
- 1 B3.22 3 WCGT 020102L

KIT  
Ø 6 ~ 30

REF.	CODE	Ø
K20.50	655000100200	6 ~ 30

- ER COLLET
- ER SPANNZANGEN
- PINZAS ER
- PINCES ER
- PINZE ER

## ER DIN 6499-B



REF.	d	D <sub>1</sub>	D <sub>2</sub>	L
ER 11	0.5 ~ 7	11	11.5	18
ER 16	0.5 ~ 10	16	17	27.5
ER 20	1 ~ 13	20	21	31.5
ER 25	1 ~ 16	25	26	34
ER 32	2 ~ 20	32	33	40
ER 40	3 ~ 26	40	41	46

RANGE	ER11	ER16	ER20	ER25	ER32	ER40
1 - 0.5	496080111010	496080116010	-	-	-	-
1.5 - 1	496080111015	496080116015	-	-	-	-
2 - 1	-	-	496080120020	496080125020	-	-
2 - 1.5	496080111020	496080116021	-	-	-	-
2.5 - 2	496080111025	496080116025	-	-	-	-
3 - 2	-	496080116030	496080120030	496080125030	496080132030	-
3 - 2.5	496080111030	-	-	-	-	-
3.5 - 3	496080111035	-	-	-	-	-
4 - 3	-	496080116040	496080120040	496080125040	496080132040	496080140040
4 - 3.5	496080111040	-	-	-	-	-
4.5 - 4	496080111045	-	-	-	-	-
5 - 4	-	496080116050	496080120050	496080125050	496080132050	496080140050
5 - 4.5	496080111050	-	-	-	-	-
5.5 - 5	496080111055	-	-	-	-	-
6 - 5	-	496080116060	496080120060	496080125060	496080132060	496080140060
6 - 5.5	496080111060	-	-	-	-	-
6.5 - 6	496080111065	-	-	-	-	-
7 - 6	-	496080116070	496080120070	496080125070	496080132070	496080140070
7 - 6.5	496080111070	-	-	-	-	-
8 - 7	-	496080116080	496080120080	496080125080	496080132080	496080140080
9 - 8	-	496080116090	496080120090	496080125090	496080132090	496080140090
10 - 9	-	496080116100	496080120100	496080125100	496080132100	496080140100
11 - 10	-	-	496080120110	496080125110	496080132110	496080140110
12 - 11	-	-	496080120120	496080125120	496080132120	496080140120
13 - 12	-	-	496080120130	496080125130	496080132130	496080140130
14 - 13	-	-	-	496080125140	496080132140	496080140140
15 - 14	-	-	-	496080125150	496080132150	496080140150
16 - 15	-	-	-	496080125160	496080132160	496080140160
17 - 16	-	-	-	-	496080132170	496080140170
18 - 17	-	-	-	-	496080132180	496080140180
19 - 18	-	-	-	-	496080132190	496080140190
20 - 19	-	-	-	-	496080132200	496080140200
21 - 20	-	-	-	-	-	496080140210
22 - 21	-	-	-	-	-	496080140220
23 - 22	-	-	-	-	-	496080140230
24 - 23	-	-	-	-	-	496080140240
25 - 24	-	-	-	-	-	496080140250
26 - 25	-	-	-	-	-	496080140260

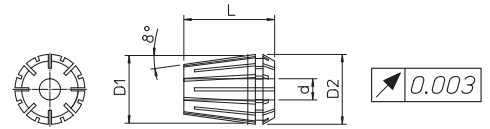
- ER collet SEALED supplied upon request • Auf Anfrage ER Spannzangen Dichtbuchsen lieferbar
- Suministrables bajo pedido pinzas ER ESTANCOS • Disponibles sur demande pinces ER étanches • Fornibili su richiesta pinze ER a TENUTA

SET ER	REF.	Ø	CODE
	SET ER11/13	0.5 ~ 7	496080111000
	SET ER16/10	0.5 ~ 10	496080116000
	SET ER20/12	1 ~ 13	496080120000
	SET ER25/15	1 ~ 16	496080125000
	SET ER32/18	2 ~ 20	496080132000
	SET ER40/23	3 ~ 26	496080140000



- ER ULTRA-PRECISE COLLET
- PRÄZISIONSSPANNZANGEN ER
- PINZAS ER ULTRA-PRECISAS
- PINCES ER EXTRAPRÉCISES
- PINZE ER EXTRAPRECISE

## ER DIN 6499-B



REF.	d	D <sub>1</sub>	D <sub>2</sub>	L
ER 16	0.5 ~ 10	16	17	27.5
ER 25	1 ~ 16	25	26	34
ER 32	2 ~ 20	32	33	40
ER 40	3 ~ 26	40	41	46

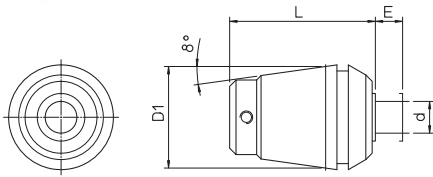
RANGE	ER16	ER25	ER32	ER40
1 - 0.5	496080016010	-	-	-
1.5 - 1	496080016015	-	-	-
2 - 1.5	496080016020	496080025020	-	-
2.5 - 2	496080016025	496080025025	496080032025	-
3 - 2.5	496080016030	496080025030	496080032030	-
3.5 - 3	496080016035	496080025035	496080032035	-
4 - 3.5	496080016040	496080025040	496080032040	496080040040
4.5 - 4	496080016045	496080025045	496080032045	496080040045
5 - 4.5	496080016050	496080025050	496080032050	496080040050
5.5 - 5	496080016055	496080025055	496080032055	496080040055
6 - 5.5	496080016060	496080025060	496080032060	496080040060
6.5 - 6	496080016065	496080025065	496080032065	496080040065
7 - 6.5	496080016070	496080025070	496080032070	496080040070
7.5 - 7	496080016075	496080025075	496080032075	496080040075
8 - 7.5	496080016080	496080025080	496080032080	496080040080
8.5 - 8	496080016085	496080025085	496080032085	496080040085
9 - 8.5	496080016090	496080025090	496080032090	496080040090
9.5 - 9	496080016095	496080025095	496080032095	496080040095
10 - 9.5	496080016100	496080025100	496080032100	496080040100
10.5 - 10	-	496080025105	496080032105	496080040105
11 - 10.5	-	496080025110	496080032110	496080040110
11.5 - 11	-	496080025115	496080032115	496080040115
12 - 11.5	-	496080025120	496080032120	496080040120
12.5 - 12	-	496080025125	496080032125	496080040125
13 - 12.5	-	496080025130	496080032130	496080040130
13.5 - 13	-	496080025135	496080032135	496080040135
14 - 13.5	-	496080025140	496080032140	496080040140
14.5 - 14	-	496080025145	496080032145	496080040145
15 - 14.5	-	496080025150	496080032150	496080040150
15.5 - 15	-	496080025155	496080032155	496080040155
16 - 15.5	-	496080025160	496080032160	496080040160
16.5 - 16	-	-	496080032165	496080040165
17 - 16.5	-	-	496080032170	496080040170
17.5 - 17	-	-	496080032175	496080040175
18 - 17.5	-	-	496080032180	496080040180
18.5 - 18	-	-	496080032185	496080040185
19 - 18.5	-	-	496080032190	496080040190
19.5 - 19	-	-	496080032195	496080040195
20 - 19.5	-	-	496080032200	496080040200
20.5 - 20	-	-	-	496080040205
21 - 20.5	-	-	-	496080040210
21.5 - 21	-	-	-	496080040215
22 - 21.5	-	-	-	496080040220
22.5 - 22	-	-	-	496080040225
23 - 22.5	-	-	-	496080040230
23.5 - 23	-	-	-	496080040235
24 - 23.5	-	-	-	496080040240
24.5 - 24	-	-	-	496080040245
25 - 24.5	-	-	-	496080040250
25.5 - 25	-	-	-	496080040255
26 - 25.5	-	-	-	496080040260

• On request • Auf Anfrage • A petición • Sur demande • Fornibili su richiesta

# D'ANDREA ACCESSORIES

- TAPPING COLLETS WITH AXIAL COMPENSATION
- SPANNZANGE MIT AXIALAUSGLEICH FÜR GEWINDEBOHRER
- PINZAS PARA ROSCADO CON COMPENSACIÓN AXIAL
- PINCES DE TARAUDAGE AVEC COMPENSATION AXIALE
- PINZE DI MASCHIATURA CON COMPENSAZIONE ASSIALE

ET-1- ER



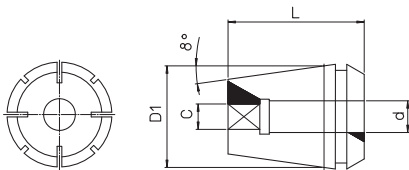
REF.	CODE	d	D <sub>1</sub>	L	E	
ET-1-ER25 (M2 ~ M12)	496086125280	2.8	26	34	8	100451012500
	496086125350	3.5				
	496086125450	4.5				
	496086125600	6				
	496086125700	7				
	496086125900	9				
ET-1-ER32 (M4 ~ M16)	496086132450	4.5	33	43	10	100451033200
	496086132600	6				
	496086132700	7				
	496086132900	9				
	496086132110	11				
	496086132120	12				
ET-1-ER40 (M8 ~ M20)	496086140600	6	41	54	13	100451034000
	496086140700	7				
	496086140900	9				
	496086140110	11				
	496086140120	12				
	496086140140	14				
	496086140160	16				

• On request • Auf Anfrage • A petición • Sur demande • Fornibili su richiesta

- TAPPING COLLETS WITHOUT AXIAL COMPENSATION
- SPANNZANGE ZUM STARREN GEWINDESCHNEIDEN
- PINZAS PARA ROSCADO RÍGIDO
- PINCES DE TARAUDAGE SANS COMPENSATION AXIALE
- PINZE PER MASCHIATURA RIGIDA

ER - GB

244



REF.	CODE	(d Ø x c	DIN 371	DIN 374-376	D <sub>1</sub>	L	
ER 16-GB (M4 ~ M10)	496085116045	4.5 x 3.4	M4	M6	16	27.5	100451011600
	496085116055	5.5 x 4.3	-	M7			
	496085116060	6 x 4.9	M5	M8			
	496085116070	7 x 5.5	M6	M10			
ER 25-GB (M4 ~ M16)	496085125045	4.5 x 3.4	M4	M6	25	34	100451012500
	496085125055	5.5 x 4.3	-	M7			
	496085125060	6 x 4.9	M5	M8			
	496085125070	7 x 5.5	-	M10			
	496085125090	9 x 7	-	M12			
	496085125110	11 x 9	-	M14			
	496085125120	12 x 9	-	M16			
	496085132045	4.5 x 3.4	M4	M6			
496085132055	5.5 x 4.3	-	M7				
ER 32-GB (M4 ~ M20)	496085132060	6 x 4.9	M5	M8	32	40	100451033200
	496085132070	7 x 5.5	-	M10			
	496085132090	9 x 7	-	M12			
	496085132110	11 x 9	-	M14			
	496085132120	12 x 9	-	M16			
	496085132140	14 x 11	-	M18			
	496085132160	16 x 12	-	M20			
	496085140070	7 x 5.5	-	M10			
496085140090	9 x 7	-	M12				
ER 40-GB (M10 ~ M27)	496085140110	11 x 9	-	M14	40	46	100451034000
	496085140120	12 x 9	-	M16			
	496085140140	14 x 11	-	M18			
	496085140160	16 x 12	-	M20			
	496085140180	18 x 14.5	-	M22			
	496085140200	20 x 16	-	M24			
	496085140200	20 x 16	-	M27			

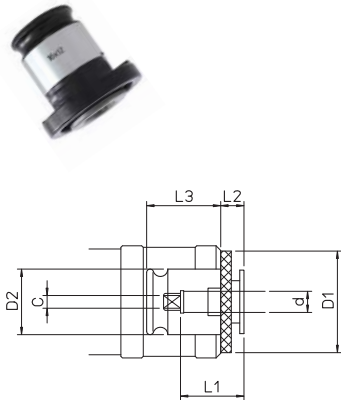
• On request • Auf Anfrage • A petición • Sur demande • Fornibili su richiesta

- For TOPRUN spindles, use ring-nuts shown in the chart
- Bei Verwendung von TOPRUN-Aufnahmen, die in der Tabelle angegebenen Spannmuttern verwenden
- Para el empleo en los mandrinos TOPRUN se precisa utilizar las tuercas indicadas en la tabla
- Sur mandrins TOPRUN utiliser les bagues indiquées dans le tableau
- Per l'utilizzo su mandrini TOPRUN utilizzare ghiera indicate in tabella



- QUICK CHANGE TAP HOLDERS WITHOUT TORQUE CLUTCH
- SCHNELLWECHSELFUTTER FÜR GEWINDEBOHRER OHNE DREHMOMENTKUPPLUNG
- MANGUITOS DE CAMBIO RÁPIDO SIN LIMITACIÓN DE PAR
- ADAPTATEURS PORTE-TARAUD SANS LIMITEUR DE COUPLE
- BUSSOLE A CAMBIO RAPIDO SENZA LIMITAZIONE DI COPPIA

BFC



REF.	CODE	(d Ø x c [°])	DIN 371	DIN 374	DIN 376	D1	D2	L1	L2	L3
BFC1 (M3 - 12)	495061035027	3.5 x 2.7	M3	M5	M5	30	19	17	7	21.5
	495061045034	4.5 x 3.4	M4	M6	M6					
	495061055043	5.5 x 4.3	-	M7	M7					
	495061060049	6 x 4.9	M5 M6	M8	M8					
	495061070055	7 x 5.5	-	M10	M10					
	495061090070	9 x 7	-	M12	M12					
BFC2 (M6 - 20)	495062060049	6 x 4.9	M5 M6	M8	M8	48	31	30	11	35
	495062070055	7 x 5.5	-	M10	M10					
	495062090070	9 x 7	-	M12	M12					
	495062110090	11 x 9	-	M14	M14					
	495062120090	12 x 9	-	M16	M16					
	495062140110	14 x 11	-	M18	M18					
	495062160120	16 x 12	-	M20	M20					
BFC3 (M14 ~ 33)	495063110090	11 x 9	-	M14	M14	70	48	44	14	55.5
	495063120090	12 x 9	-	M16	M16					
	495063140110	14 x 11	-	M18	M18					
	495063160120	16 x 12	-	M20	M20					
	495063180145	18 x 14.5	- -	M22 M24	M22 M24					
	495063200160	20 x 16	-	M27	M27					
	495063220180	22 x 18	-	M30	M30					
	495063250200	25 x 20	-	M33	M33					

• On request • Auf Anfrage • A petición • Sur demande • Fornibili su richiesta

- QUICK CHANGE TAP HOLDERS WITH TORQUE CLUTCH
- SCHNELLWECHSELFUTTER FÜR GEWINDEBOHRER MIT DREHMOMENTKUPPLUNG
- MANGUITOS DE CAMBIO RÁPIDO CON LIMITACIÓN DE PAR
- ADAPTATEURS PORTE-TARAUD AVEC LIMITEUR DE COUPLE
- BUSSOLE A CAMBIO RAPIDO CON LIMITAZIONE DI COPPIA

BFS

245



REF.	CODE	(d Ø x c [°])	DIN 371	DIN 374	DIN 376	D1	D2	L1	L2	L3
BFS1 (M3 - 12)	495071035027	3.5 x 2.7	M3	M5	M5	32	19	17	25	21.5
	495071040030	4 x 3	M3.5	-	-					
	495071045034	4.5 x 3.4	M4	M6	M6					
	495071055043	5.5 x 4.3	-	M7	M7					
	495071060049	6 x 4.9	M5 M6	M8	M8					
	495071070055	7 x 5.5	-	M10	M10					
	495071080062	8 x 6.2	M8	-	-					
	495071090070	9 x 7	-	M12	M12					
	495071100080	10 x 8	M10	-	-					
BFS2 (M6 - 20)	495072060049	6 x 4.9	M5 M6	M8	M8	50	31	30	34	35
	495072070055	7 x 5.5	-	M10	M10					
	495072080062	8 x 6.2	M8	-	-					
	495072090070	9 x 7	-	M12	M12					
	495072100080	10 x 8	M10	-	-					
	495072110090	11 x 9	-	M14	M14					
	495072120090	12 x 9	-	M16	M16					
	495072140110	14 x 11	-	M18	M18					
495072160120	16 x 12	-	M20	M20						
BFS3 (M14 ~ 33)	495073110090	11 x 9	-	M14	M14	72	48	44	45	55.5
	495073120090	12 x 9	-	M16	M16					
	495073140110	14 x 11	-	M18	M18					
	495073160120	16 x 12	-	M20	M20					
	495073180145	18 x 14.5	- -	M22 M24	M22 M24					
	495073200160	20 x 16	-	M27	M27					
	495073220180	22 x 18	-	M30	M30					
495073250200	25 x 20	-	M33	M33						

• On request • Auf Anfrage • A petición • Sur demande • Fornibili su richiesta



# D'ANDREA

## TECHNICAL DATA

- TECHNICAL DATA
- TECHNISCHE DATEN
- DATOS TÉCNICOS
- DONNÉES TECHNIQUES
- DATI TECNICI

246

Werkzeuge  
Werkzeugwechsel  
Ausführung mit Datenträger

Oktober 1995

**DIN**  
69871-1

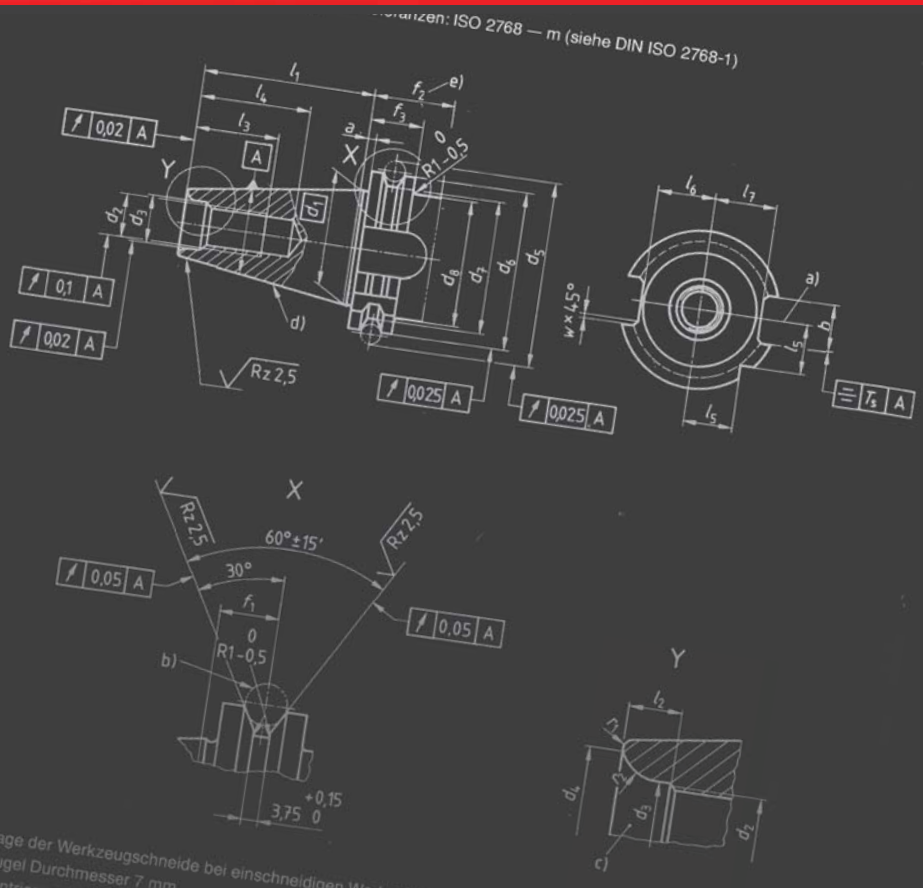
Ersatz für Ausgabe 1990-03

Metallkegelschaft, NC-Maschine

Werkzeuge (FWS),  
manuell und automati-  
siert

ISO  
Zentrierung

a) Lage der Werkzeugschneide bei einschneidigen Werkzeugen  
b) Kugel Durchmesser 7 mm  
c) Zentrierung: 60° mit Schutz  
d) Kegel

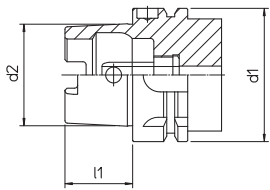




- ARBORS STANDARDS
- NORMEN FÜR GRUNDAUFNAHMEN
- NORMAS ACOPLAMIENTOS BASE
- NORMES MANDRINS
- NORME ATTACCHI BASE

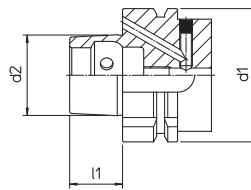
DIN 69893

## HSK-A



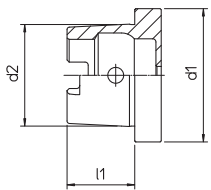
HSK-A	d1	d2	l1
32	32	24	16
40	40	30	20
50	50	38	25
63	63	48	32
80	80	60	40
100	100	75	50

## HSK-B



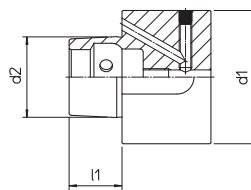
HSK-B	d1	d2	l1
-	-	-	-
40	40	24	16
50	50	30	20
63	63	38	25
80	80	48	32
100	100	60	40

## HSK-C



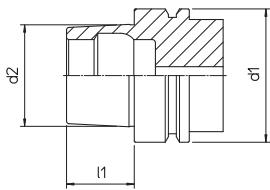
HSK-C	d1	d2	l1
32	32	24	16
40	40	30	20
50	50	38	25
63	63	48	32
80	80	60	40
100	100	75	50

## HSK-D



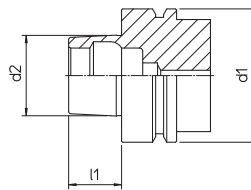
HSK-D	d1	d2	l1
-	-	-	-
40	40	24	16
50	50	30	20
63	63	38	25
80	80	48	32
100	100	60	40

## HSK-E



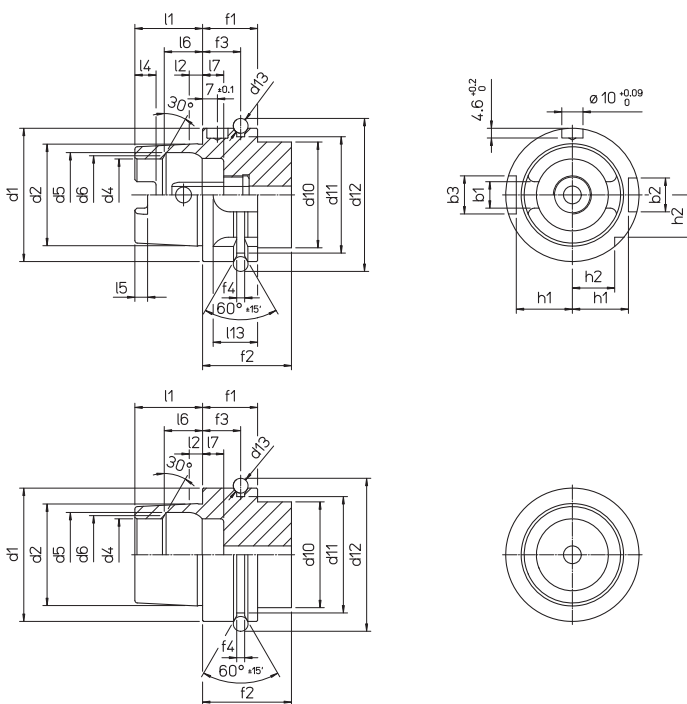
HSK-E	d1	d2	l1
32	32	24	16
40	40	30	20
50	50	38	25
63	63	48	32
-	-	-	-

## HSK-F



HSK-F	d1	d2	l1
-	-	-	-
-	-	-	-
50	50	30	20
63	63	38	25
80	80	48	32

## HSK-A HSK-E



## HSK-T

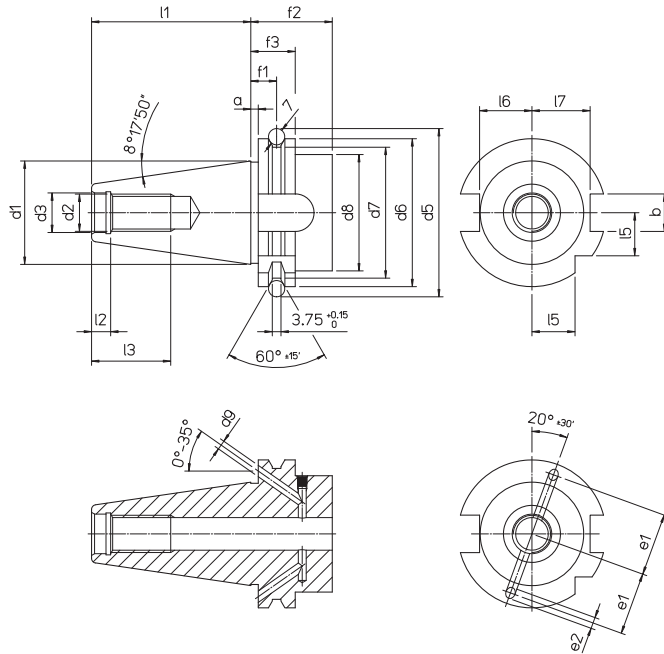
HSK-T	32	40	50	63	80	100
b1 <sup>+0.04</sup> <sub>-0.04</sub>	7.05	8.05	10.54	12.54	16.04	20.02
b5	6.932	7.932	10.425	12.425	15.93	19.91
		<sup>+0.03</sup> <sub>0</sub>		<sup>+0.035</sup> <sub>0</sub>		

HSK	32	40	50	63	80	100
b1 <sup>+0.04</sup> <sub>-0.04</sub>	7.05	8.05	10.54	12.54	16.04	20.02
b2 H10	7	9	12	16	18	20
b3 H10	9	11	14	18	20	22
d1 h10	32	40	50	63	80	100
d2	24 <sup>+0.007</sup> <sub>+0.005</sub>	30 <sup>+0.007</sup> <sub>+0.005</sub>	38 <sup>+0.009</sup> <sub>+0.008</sub>	48 <sup>+0.011</sup> <sub>+0.007</sub>	60 <sup>+0.013</sup> <sub>+0.008</sub>	75 <sup>+0.015</sup> <sub>+0.009</sub>
d4 H10	17	21	26	34	42	53
d5 H11	21	25.5	32	40	50	63
d6	19	23	29	37	46	58
d10 max.	26	34	42	53	67	85
d11 <sup>0</sup> <sub>-0.01</sub>	26.5	34.8	43	55	70	92
d12 <sup>0</sup> <sub>-0.01</sub>	37	45	59.3	72.3	88.8	109.75
d13	4		7			
f1 <sup>0</sup> <sub>-0.01</sub>	20		26		29	
f2 min.	35		42		45	
f3 ± 0.01	16		18		20	
f4 <sup>+0.15</sup> <sub>0</sub>	2		3.75			
h1 <sup>0</sup> <sub>-0.2</sub>	13	17	21	26.5	34	44
h2 <sup>0</sup> <sub>-0.13</sub>	9.5	12	15.5	20	25	31.5
l1 <sup>0</sup> <sub>-0.2</sub>	16	20	25	32	40	50
l2	3.2	4	5	6.3	8	10
l4 <sup>+0.2</sup> <sub>0</sub>	5	6	7.5	10	12	15
l5 <sup>+0.2</sup> <sub>0</sub>	3	3.5	4.5	6	8	10
l6 JS10	8.92	11.42	14.13	18.13	22.85	28.56
l7 <sup>0</sup> <sub>-0.1</sub>	8		10	10	12.5	12.5
l13	12		19	21	22	24



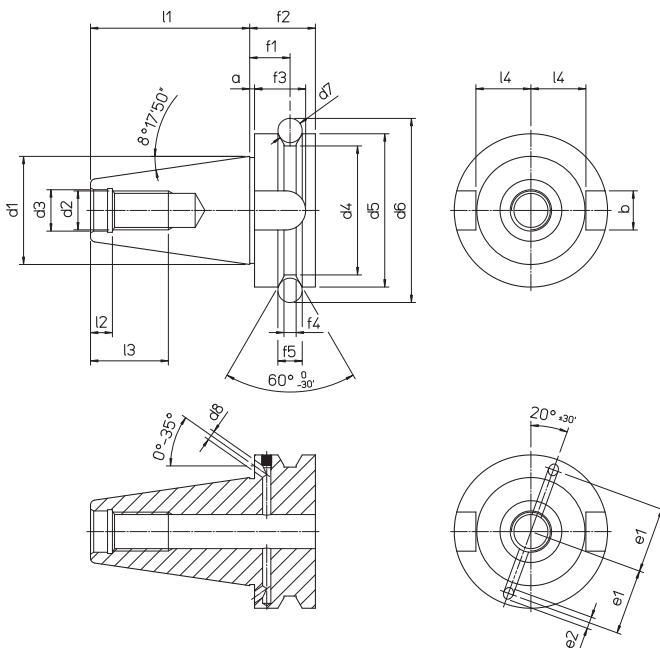
- ARBORS STANDARDS
- NORMEN FÜR GRUNDAUFNAHMEN
- NORMAS ACOPLAMIENTOS BASE
- NORMES MANDRINS
- NORME ATTACCHI BASE

## DIN 69871 A-B



ISO	30	40	45	50	60
a ± 0.01	3.2				
b H12	16.1		19.3	25.7	
d1	31.75	44.45	57.15	69.85	107.95
d2	M12	M16	M20	M24	M30
d3 H7	13	17	21	25	32
d5 ± 0.05	59.3	72.3	91.35	107.25	164.75
d6 $\begin{smallmatrix} 0 \\ -0.1 \end{smallmatrix}$	50	63.55	82.55	97.50	155
d7 $\begin{smallmatrix} 0 \\ -0.5 \end{smallmatrix}$	44.3	56.25	75.25	91.25	147.70
d8 max.	45	50	63	80	130
d9	4		5	6	8
e1 ± 0.1	21	27	35	42	66
e2 max.	5		6	7	9,2
f1 ± 0.1	11.1				
f2 min.	35				38
f3 $\begin{smallmatrix} 0 \\ -0.1 \end{smallmatrix}$	19.1				
l1 $\begin{smallmatrix} 0 \\ -0.3 \end{smallmatrix}$	47.8	68.4	82.7	101.75	161.80
l2 $\begin{smallmatrix} +0.5 \\ 0 \end{smallmatrix}$	5.5	8.2	10	11.5	14
l3 min.	24	32	40	47	59
l5 $\begin{smallmatrix} 0 \\ -0.3 \end{smallmatrix}$	15	18.5	24	30	49
l6 $\begin{smallmatrix} 0 \\ -0.4 \end{smallmatrix}$	16.4	22.8	29.1	35.5	54,5
l7 $\begin{smallmatrix} 0 \\ -0.4 \end{smallmatrix}$	19	25	31.3	37.7	59,3

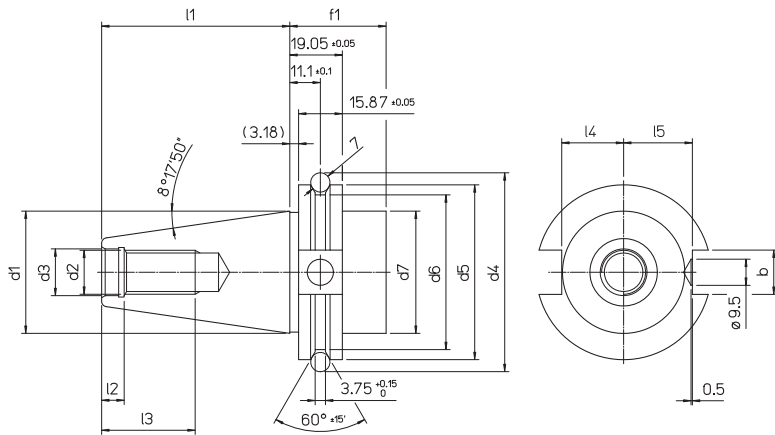
## MAS 403 BT A-B



ISO	30	35	40	45	50	60
a ± 0.04	2		3			
b H12	16.1			19.3	25.7	25,7
d1	31.75	38.10	44.45	57.15	69.85	107,95
d2	M 12		M 16	M 20	M 24	M30
d3 H8	12.5		17	21	25	31
d4	38	43	53	73	85	135
d5 h8	46	53	63	85	100	155
d6	56.144	65.680	75.679	100.215	119.019	180,359
d7	8	10		12	15	20
d8	4			5	6	8
e1 ± 0.1	21	23	27	35	42	66
e2 max.	5			6	7	9,2
f1 ± 0.1	13.6	14.6	16.6	21.2	23.2	28,2
f2	22	24	27	33	38	4,8
f3 min.	17	20	21	26	31	34
f4	4	5		6	7	11
f5 $\begin{smallmatrix} +0.1 \\ 0 \end{smallmatrix}$	8	10		12	15	20
l1 ± 0.2	48.4	56.4	65.4	82.8	101.8	161,8
l2 $\begin{smallmatrix} +0.5 \\ 0 \end{smallmatrix}$	7		9	11	13	16
l3 min.	24		30	38	45	56
l4 $\begin{smallmatrix} 0 \\ -0.2 \end{smallmatrix}$	16.3	19.6	22.6	29.1	35.4	60,1

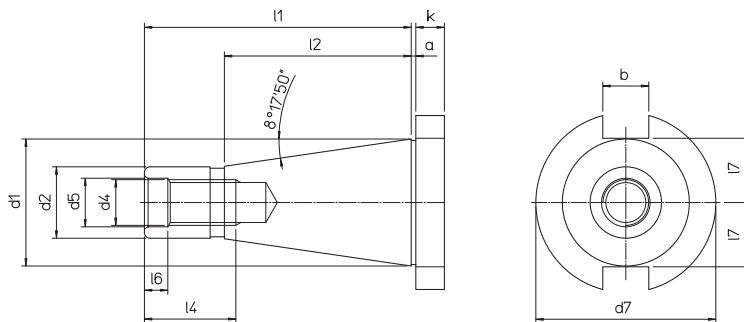
- ARBORS STANDARDS
- NORMEN FÜR GRUNDAUFNAHMEN
- NORMAS ACOPLAMIENTOS BASE
- NORMES MANDRINS
- NORME ATTACCHI BASE

## ANSI/CAT

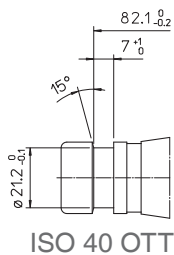


ISO	ANSI/CAT		
	40	45	50
b $^{+0.2}_0$	16.1	19.3	25.7
d1	44.45	57.15	69.85
d2	M 16	M 20	M 24
d3 H7	17	21	25
d4 $\pm 0.05$	72.3	91.35	107.25
d5 $^0_{-0.1}$	63.55	82.55	98.45
d6 $^0_{-0.5}$	56.25	75.25	91.25
d7 $\pm 0.25$	44.45	57.15	69.85
f1 $\pm 0.25$	35		36.5
l1 $^0_{-0.3}$	68.4	82.7	101.75
l2 $^{+0.5}_0$	4.75	5.25	5.75
l3 min.	30	38	45
l4 $^0_{-0.4}$	22.8	29.10	35.50
l5 $^0_{-0.4}$	25	31.3	37.7

## DIN 2080

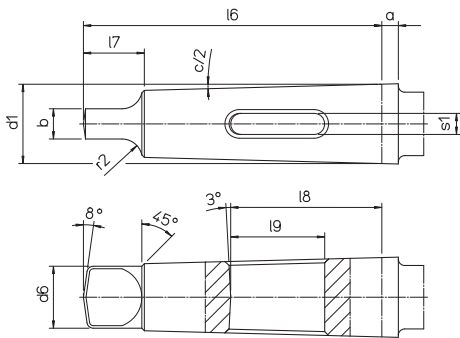


ISO	DIN 2080			
	30	40	45	50
a $\pm 0.2$	1.6		3.2	
b H12	16.1		19.3	25.7
d1	31.75	44.45	57.15	69.85
d2 a10	17.4	25.3	32.4	39.6
d4 $\pm 0.05$	M 12	M 16	M 20	M 24
d5	13	17	21	26
d7 $^0_{-0.4}$	50	63	80	97.5
k $\pm 0.15$	8	10	12	12
l1	68.4	93.4	106.8	126.8
l2	48.4	65.4	82.8	101.8
l4	24	32	40	47
l6 $^{+0.5}_0$	5.5	8.2	10	11.5
l7 max.	16.2	22.5	29	35.3



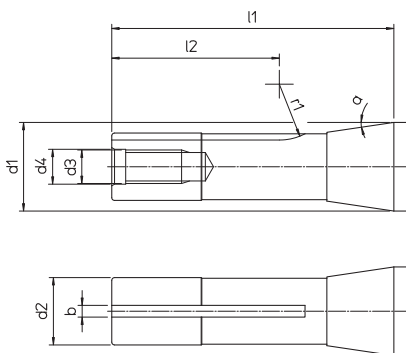
- ARBORS STANDARDS
- NORMEN FÜR GRUNDAUFNAHMEN
- NORMAS ACOPLAMIENTOS BASE
- NORMES MANDRINS
- NORME ATTACCHI BASE

## DIN 228/B DIN 1806



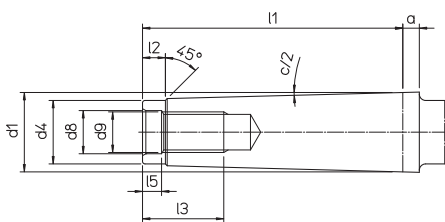
MORSE	4	5
a	6.5	
b H13	11.9	15.9
c/2	1°29'15"	1°30'26"
d1	31.267	44.399
d6 max.	24.5	35.7
l6 $\begin{smallmatrix} 0 \\ -1 \end{smallmatrix}$	117.5	149.5
l7 max.	24	29
l8	59.5	64
l9	37	42
r2	8	10
s1	8.3	12.4

## R8



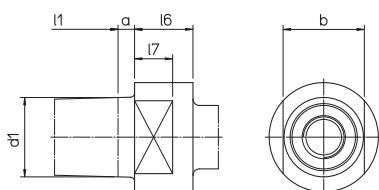
R8	
a	8°25'30"
b $\pm 0.1$	4.2
d1	31.750
d2	24.109
d3 $\begin{smallmatrix} -0.007 \\ -0.020 \end{smallmatrix}$	M 12
d4	12.5
l1	101
l2 min.	60
r1	20

## DIN 228/A



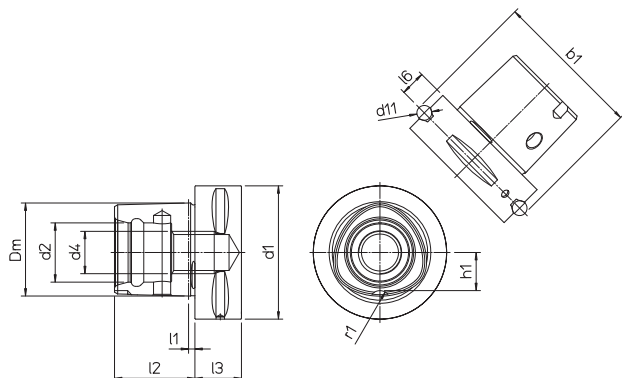
MORSE	4	4 SIP
a	6.5	
b $d_9$	32	
c/2	1°29'15"	
d1	31.267	
d4 max.	25	
d8	17	
d9	M 16	M 14
l1 max.	102.5	
l2	9	
l3	32	
l5 $\begin{smallmatrix} +0.5 \\ 0 \end{smallmatrix}$	8.2	
l6	15	
l7	23	

## DIN 2207



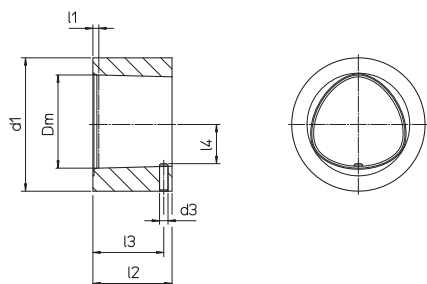


ISO 26623-1



PSC	32	40	50	63	80	100
b1 ±0.1	39	46	59.3	70.7	86	110
Dm	22	28	35	44	55	72
d1 ±0.1	32	40	50	63	80	100
d2 <sup>+0.1</sup> / <sub>-0.05</sub>	15	18	21	28	32	43
d4	M12x1.5	M14x1.5	M16x1.5	M20x2		M24x2
d11	5		7			10
l1	2.5		3			
l2 ±0.1	19	24	30	38	48	60
l3 min	15	20		22	30	36
l6 ±0.15	6	8	10	12		16
h1 ±0.1	9	11	14	18	22.2	29
r1 <sup>+2</sup> / <sub>0</sub>	3	3	4	5	6	8

ISO 26623-2



PSC	32	40	50	63	80	100
Dm	22	28	35	44	55	72
d1 min	32	40	50	63	80	100
d3	2	2.5	3	4	5	6
l1	2.3	2.3	2.8	2.8	2.8	2.8
l2 F 0.1	18.4	23.4	29.4	37.4	47.4	59.4
l3 F 0.2	16.5	21	26	33.5	43	52.5
l4	9.4 ±0.1	11.5 ±0.2	14.5 ±0.2	18.5 ±0.2	22.8 ±0.2	29.6



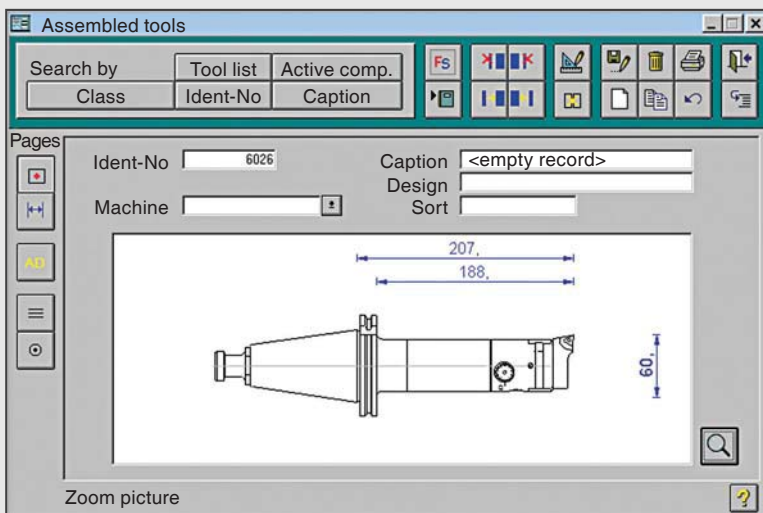
**B** It allows to be graphically constructed in a short period of time, showing the complete composition of the Modulhard'Andrea tools, including dimensions, weight and the list of components.

**D** Der Grafikgenerator ermöglicht in kurzer Zeit das Zusammenstellen kompletter Werkzeuge mit MODULHARD'ANDREA-Elementen, indem er die Abmessungen, das Gewicht und die Liste der Bauteile angibt.

**E** Generador gráfico que permite componer en breve tiempo herramientas completas con elementos del MODULHARD'ANDREA, indicando las dimensiones, el peso y la lista de los componentes.

**F** Générateur graphique qui permet de composer, en peu de temps, des outils complets avec des éléments du MODULHARD'ANDREA, tout en indiquant les dimensions, le poids et la liste des composants.

**I** Generatore grafico che permette di comporre in breve tempo utensili completi con elementi del MODULHARD'ANDREA, indicando le dimensioni, il peso e la lista dei componenti.



**Tool assembling** 6019

< empty record > Machine:

Diam:	Cutting Ø	Radius: Ø	Angle: Ø
60		207, 188,	0

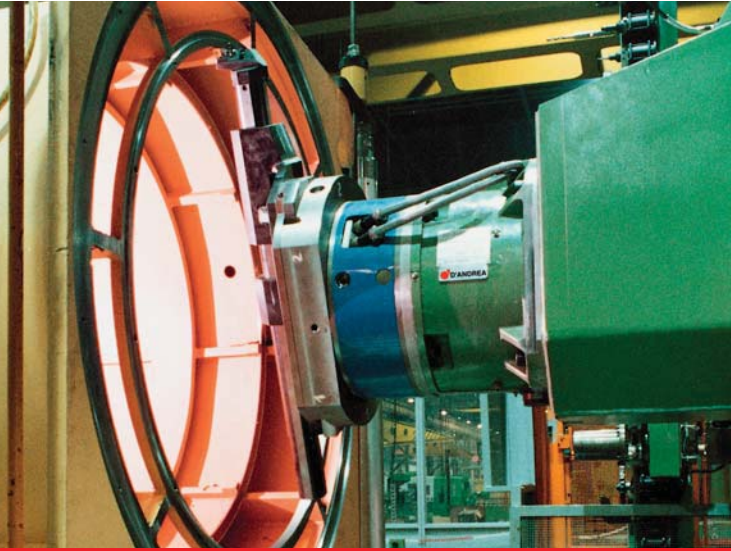
Quant	Description	Design 1 Article	Weight	Price
1	ISO7380/2-B ANSI B5.50	45° 20 143 025 1501	0,000	0,00
1	DIN 69871 A-D 50 MHD50	41 6 50 01 050 20 MHD50	2,700	0,00
1	PR 50 80	65 69 050 0080 0	1,100	0,00
1	TRM 50/50	D 2,5-84 45 50 050 0050 0	1,000	0,00
1	SFTP 50	TPGX 1103 . L 47 050 05 50 001	0,080	0,00
			<b>4,880</b>	<b>0,00</b>

**WinTool** 15.08.2015



# HEADS

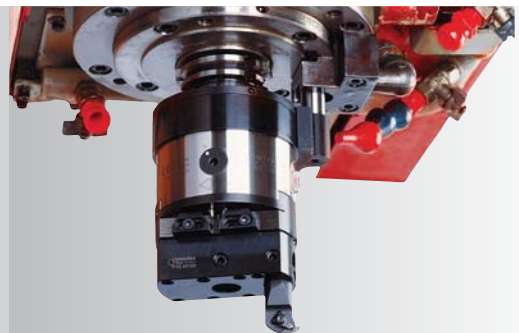
use your head



*"Super sized" performance*



*Turning operations on all machining centres*

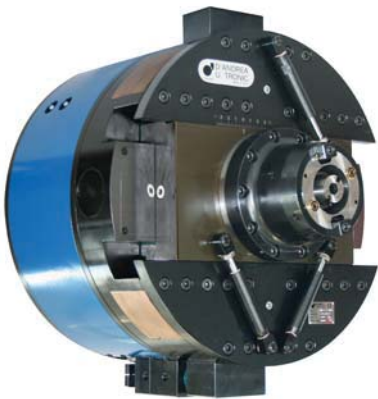
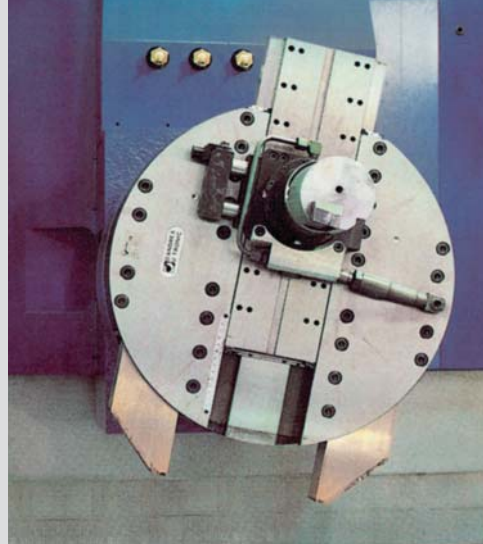
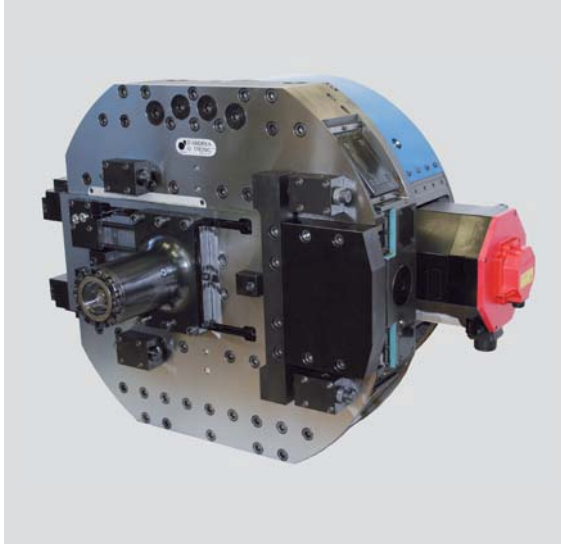


*For automatic facing*

*Unit and transfer solutions*



Made in Italy



SPECIAL and SYNCHRO



U-TRONIC



TA-CENTER



TA-TRONIC



U-COMAX



AUTORADIAL

---





- 
- GB** Medium and large sized NC boring and facing heads for boring machines, machining centers, and special machinery, which are applied manually, automatically, and with palletized systems on boring machines, machining centers, and special machinery.
- D** Mittelgrosse und große Köpfe zum ausreiben und planbearbeiten mit numerischer Steuerung auf Bohrmaschinen, Bearbeitungszentren und Spezialmaschinen mit manueller, automatischer sowie durch Palettiersystemen zu erfolgreicher Anbringung auf Bohrmaschinen, Bearbeitungszentren und Spezialmaschinen.
- E** Cabezales de medias y grandes dimensiones para mandrinar y refrentar a control numérico en mandrinadoras, centros de trabajo y máquinas especiales, que se aplican manualmente, automáticamente o con sistemas paletizados, en mandrinadoras, centros de trabajo y máquinas especiales.
- F** Têtes aux moyennes et grandes dimensions pour aléser et dresser, à commande numérique, sur des aléseuses, des centres d'usinage et des machines spéciales, qui s'appliquent manuellement, automatiquement et avec des systèmes palettisés sur des aléseuses, des centres d'usinage et des machines spéciales.
- I** Teste di medie e grandi dimensioni per alesare e sfacciare a controllo numerico su alesatrici, centri di lavoro e macchine speciali, che si applicano manualmente, automaticamente e con sistemi palletizzati, su alesatrici, centri di lavoro e macchine speciali.
- 

- GB** Numerical control boring and facing heads with automatic balancing on machining centers with automatic tool change and special machines.
- D** Köpfe mit automatischer Auswuchtung zum Ausbohren und Planschleifen mit numerischer Steuerung auf Bearbeitungszentren mit automatischem Werkzeugwechsel und Spezialmaschinen.
- E** Cabezales con equilibrado automático para mandrinar y refrentar a control numérico en centros de mecanizado y máquinas especiales con cambio automático de la herramienta.
- F** Têtes à aléser et à dresser avec équilibrage automatique, à commande numérique, pour les centres d'usinage et les machines spéciales, avec changement automatique de l'outil.
- I** Teste con bilanciatura automatica per alesare e sfacciare a controllo numerico per centri di lavoro con cambio automatico dell'utensile e macchine speciali.
- 

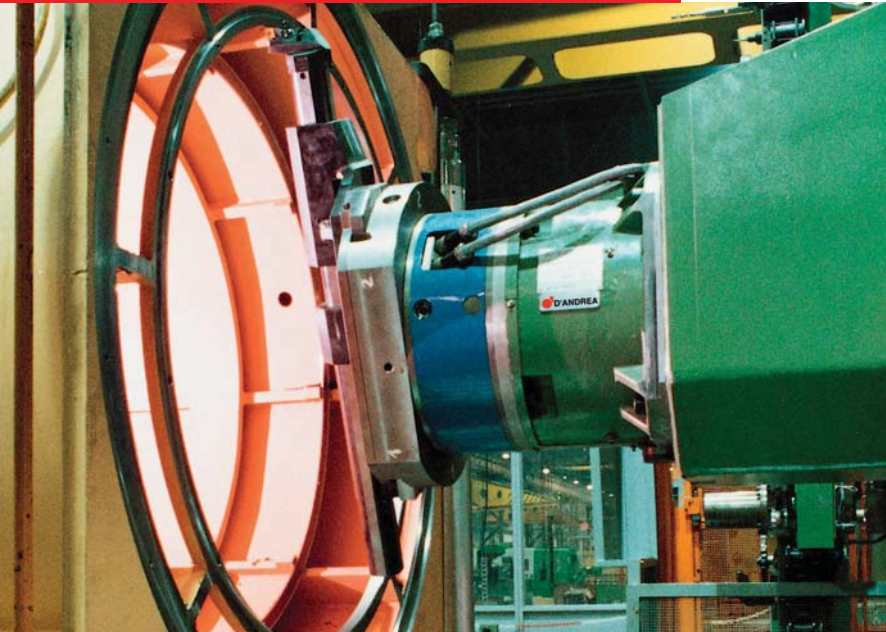
- GB** Heads with automatic balancing for numerical control boring and facing, which are applied manually, automatically, and with palletized systems, on boring machines, machining centres, and special machinery.
- D** Köpfe mit automatischem Ausgleich zum ausreiben und planbearbeiten mit numerischer Steuerung, welche manuell, automatisch und mittels Palettiersystemen auf Bohrmaschinen, Bearbeitungszentren und Spezialmaschinen angebracht werden.
- E** Cabezales con equilibrado automático para mandrinar y refrentar a control numérico, que se aplican manualmente, automáticamente y o con sistemas paletizados, en mandrinadoras, centros de trabajo y máquinas especiales.
- F** Têtes avec équilibrage automatique pour aléser et dresser, à commande numérique, qui s'appliquent manuellement, automatiquement et avec des systèmes palettisés sur des aléseuses, des centres d'usinage et des machines spéciales.
- I** Teste con bilanciatura automatica per alesare e sfacciare a controllo numerico, che si applicano manualmente, automaticamente e con sistemi palletizzati, su alesatrici, centri di lavoro e macchine speciali.
- 

- GB** NC axial control boring and facing heads on transfer machines and machining units, which are rigidly applied to machinery spindles.
- D** Köpfe mit Achssteuerung zum ausreiben und planbearbeiten mit numerischer Steuerung auf Transfermaschinen und Bearbeitungseinheiten, welche steif an die Spindeln der Maschinen angebracht werden.
- E** Cabezales de control axial para mandrinar y refrentar a control numérico en máquinas transfer y estaciones de mecanizado, que se aplican firmemente a los husillos de las máquinas.
- F** Têtes à commande axiale pour aléser et dresser, à commande numérique, sur des tables transfert et des unités opérationnelles, qui s'appliquent de façon rigide aux broches des machines.
- I** Teste a comando assiale per alesare e sfacciare a controllo numerico su macchine transfer e unità operatrici, che si applicano rigidamente ai mandrini delle macchine.
- 

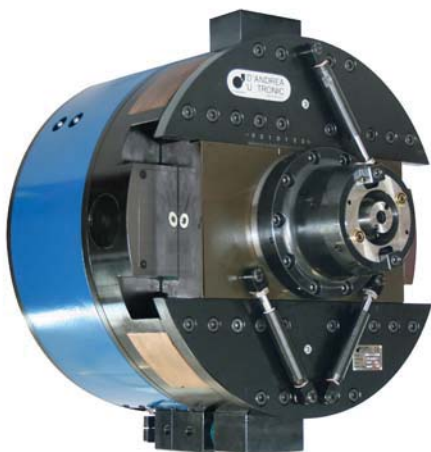
- GB** Heads with automatic feed and rapid return of the slide for facing operations on machining centers and special machinery with automatic tool changing, which does not require electronic interfaces.
- D** Köpfe mit automatischem Vorschub und Rücklauf des Schlittens zum planbearbeiten auf Bearbeitungszentren und Spezialmaschinen mit automatischem Werkzeugwechsel, ohne Bedarf elektronischer Schnittstellen.
- E** Cabezales con avance y retroceso rápido automático de la corredera para refrentar en centros de trabajo y máquinas especiales con cambio automático de la herramienta, que no necesitan interfaces electrónicos.
- F** Têtes avec avance et retour rapide automatique du coulisseau pour dresser sur des centres d'usinage et des machines spéciales avec changement automatique de l'outil, qui n'ont pas besoin d'interfaces électroniques.
- I** Teste con avanzamento e ritorno rapido automatico della slitta per sfacciare su centri di lavoro e macchine speciali con cambio automatico dell'utensile, che non necessitano di interfacce elettroniche.
-



- GENERAL FEATURES
- ALLGEMEINE MERKMALE
- CARACTERÍSTICAS GENERALES
- CARACTÉRISTIQUES GÉNÉRALES
- CARATTERISTICHE GENERALI



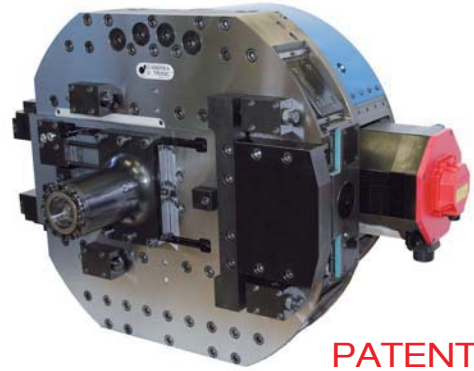
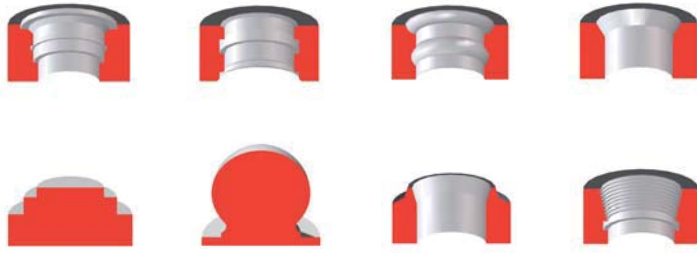
*“Super sized” performance*



Ⓛ U-TRONIC are medium and large sized CN heads that are connected to the U axis of the CNC in the tooling machine for outer facing, inner facing, back-facing, cylindrical and conical boring and threading, concave and convex radius machining through the interpolation with the other axes of the tooling machine. They can be applied manually or automatically and with pallet systems on boring machines, machining centres and special machines. They are constructed in 6 standard models from  $\varnothing 360$  to  $\varnothing 1000$  mm. All these include an internal passage for coolant. Special versions of U-TRONIC up to 1600 in diameter, with two slides or with counterweights for self-balancing, may be supplied if required. Fixed tool holders may be applied to the slide, with either manual or automatic tool changers.

Ⓛ U-TRONIC sind mittelgroße und große CN Köpfe, welche an die CNC U Achse der Werkzeugmaschine zum Ausführen von Außen-Innen- und Unterschnittplanbearbeitungen, zum zylindrischen und konischen Bohren und Gewindeschneiden, sowie für konkave und konvexe Radiusbearbeiten mittels Interpolation mit den anderen Achsen der Werkzeugmaschine angeschlossen werden. Sie werden manuell oder automatisch, sowie mit Palettiersystemen auf Bohrmaschinen, Arbeitszentren und Spezialmaschinen angebracht. Es sind 6 Standardmodelle von  $\varnothing 360$  bis  $\varnothing 1000$  mm alle mit interner Kühlmittelzufuhr, verfügbar. U-TRONIC in Spezialausgabe, bis  $\varnothing 1600$ , mit zwei Schlitten oder Gegengewichten zur Selbstbalancierung können auf Anfrage geliefert werden. Auf dem Schlitten können feste Werkzeughalter mit manuellem oder automatischem Werkzeugwechsel angebracht werden.





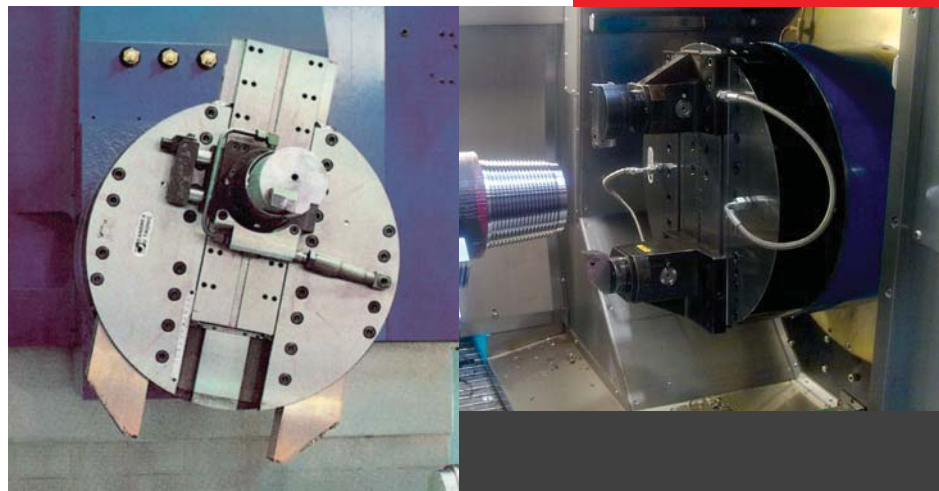
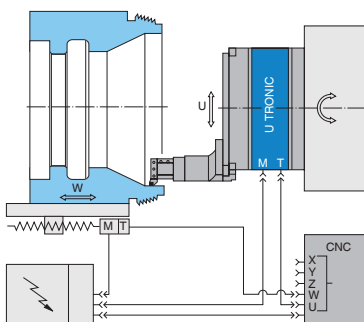
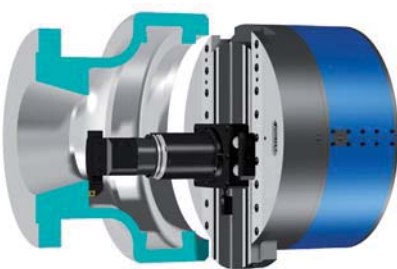
**PATENTED**



**E** Los U-TRONIC son cabezales de CN de medias y grandes dimensiones que se conectan al eje U del CNC de la máquina herramienta para elaboraciones de refrentados externos, internos y corte en ángulo, mandrinados y roscas cilíndricas y cónicas, radios cóncavos y convexos, mediante la interpolación con los otros ejes de la máquina herramienta. Se aplican manual, automáticamente y con sistemas paletizados en mandrinadoras, centros de trabajo y máquinas especiales. Están construidas en 6 modelos estándar de  $\varnothing 360$  a  $\varnothing 1000$  mm todas con paso interno del líquido refrigerante. U-TRONIC en versiones especiales hasta los  $\varnothing 1600$ , de dos correderas o con contrapesos para el autoequilibrado, se pueden suministrar bajo pedido. En la corredera se pueden aplicar portaherramientas fijos, de cambio manual o de cambio automático de la herramienta.

**F** Les U-TRONIC sont des têtes à commande numérique, aux moyennes et grandes dimensions, qui se fixent à l'axe U de la commande numérique de la machine outil pour les usinages de dressages externes, internes et contre-dépouille, alésages et filetages cylindriques et coniques, rayons de courbure concaves et convexes par l'interpolation avec les autres axes de la machine-outil. Elles s'appliquent manuellement, automatiquement et à l'aide de systèmes palettisés sur les aléseuses, centres d'usinage et machines spéciales. Elles sont construites en 6 modèles standard, de diamètre allant de  $\varnothing 360$  à  $\varnothing 1000$  mm. Toutes sont dotées d'un passage interne de liquide réfrigérant. Des U-TRONIC en versions spéciales jusqu'à  $\varnothing 1600$ , à deux coulisseaux, ou avec des contrepoids pour l'équilibrage automatique, peuvent être fournies sur demande. Il est possible d'appliquer sur le coulisseau des porte-outils fixes, avec changement manuel ou automatique de l'outil.

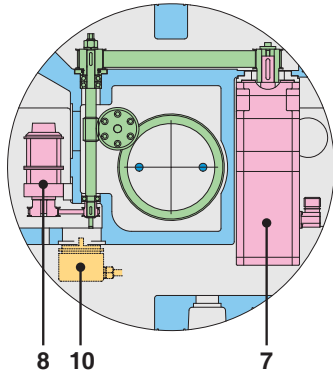
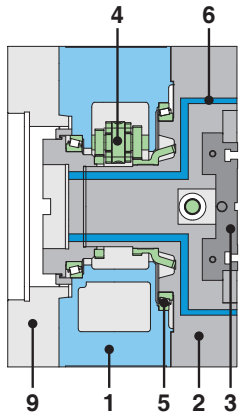
**I** Le U-TRONIC sono teste a CN di medie e grandi dimensioni che si collegano all'asse U del CNC della macchina utensile per lavorazioni di sfacciatore esterne, interne e sottosquadra, alesature e filettature cilindriche e coniche, raggature concave e convesse, mediante l'interpolazione con gli altri assi della macchina utensile. Si applicano manualmente, automaticamente e con sistemi pallettizzati su alesatrici, centri di lavoro e macchine speciali. Sono costruite in 6 modelli standard da  $\varnothing 360$  a  $\varnothing 1000$  mm tutte con passaggio interno del liquido refrigerante. U-TRONIC in versioni speciali fino a  $\varnothing 1600$ , a due slitte o con contrappesi per l'autobilanciamento, possono essere fornite a richiesta. Sulla slitta si possono applicare portautensili fissi, a cambio manuale o a cambio automatico dell'utensile.





# D'ANDREA U-TRONIC

- COMPONENTS
- KOMPONENTEN
- COMPONENTES
- COMPOSANTS
- COMPONENTI



- |  |   |
|--|---|
| <p><b>1</b></p> <ul style="list-style-type: none"> <li>• Stationary body</li> <li>• Fixe Einheit</li> <li>• Cuerpo fijo</li> <li>• Corps fixe</li> <li>• Corpo fisso</li> </ul> <p><b>2</b></p> <ul style="list-style-type: none"> <li>• Rotating body</li> <li>• Rotierender Körper</li> <li>• Cuerpo giratorio</li> <li>• Corps rotatif</li> <li>• Corpo rotante</li> </ul> <p><b>3</b></p> <ul style="list-style-type: none"> <li>• Tool slide</li> <li>• Werkzeugschlitten</li> <li>• Guía portaherramientas</li> <li>• Coulisseau</li> <li>• Slitta portautensili</li> </ul> <p><b>4</b></p> <ul style="list-style-type: none"> <li>• Gears</li> <li>• Getriebe</li> <li>• Cinematismo</li> <li>• Cinématique</li> <li>• Cinematismo</li> </ul> <p><b>5</b></p> <ul style="list-style-type: none"> <li>• Bearings</li> <li>• Lager</li> <li>• Rodamientos</li> <li>• Paliers</li> <li>• Cuscinetti</li> </ul> | <p><b>6</b></p> <ul style="list-style-type: none"> <li>• Coolant way</li> <li>• Kühlmittelzuführung</li> <li>• Paso de refrigerante</li> <li>• Passage liquide d'arrosage réfrigérant</li> <li>• Passaggio refrigerante</li> </ul> <p><b>7</b></p> <ul style="list-style-type: none"> <li>• Servomotor</li> <li>• Servomotor</li> <li>• Servomotor</li> <li>• Servomoteur</li> <li>• Servomotore</li> </ul> <p><b>8</b></p> <ul style="list-style-type: none"> <li>• Limit switches</li> <li>• Endschalter</li> <li>• Microinterruptores de fin de carrera</li> <li>• Minirrupteurs de fin de course</li> <li>• Microinterruttori di finecorsa</li> </ul> <p><b>9</b></p> <ul style="list-style-type: none"> <li>• Flange</li> <li>• Flansch</li> <li>• Brida</li> <li>• Bride</li> <li>• Flangia</li> </ul> <p><b>10</b></p> <ul style="list-style-type: none"> <li>• Encoder up on request</li> <li>• Encoder auf Anfrage</li> <li>• Encoder bajo petición</li> <li>• Événtuel fourni sur demande</li> <li>• Encoder a richiesta</li> </ul> |
|--|---|



**GB PREARRANGEMENTS.** U-TRONIC heads are prearranged with holes that allow coolants to pass through. It is also possible to enter air from the holes provided on the fixed body, in order to pressurize the motor and limit switch area, to automatically lubricate the internal kinematic motion and lubricate the slide guiding rails and lead screw with sprayed oil.

**D VERANLAGEUNG.** Die TA-CENTER-Köpfe wurden mit Gegengewichten zum Durchfluss des Kühlmittels entwickelt. Es ist auch möglich, Gegengewichte mit automatischem Vorschub und Rücklauf des Schlittens zum Planschleifen auf Bearbeitungszentren und Spezialmaschinen mit automatischem Werkzeugwechsel bei einer hohen Umdrehungsanzahl ohne nennenswerte Schwingungen zu arbeiten.

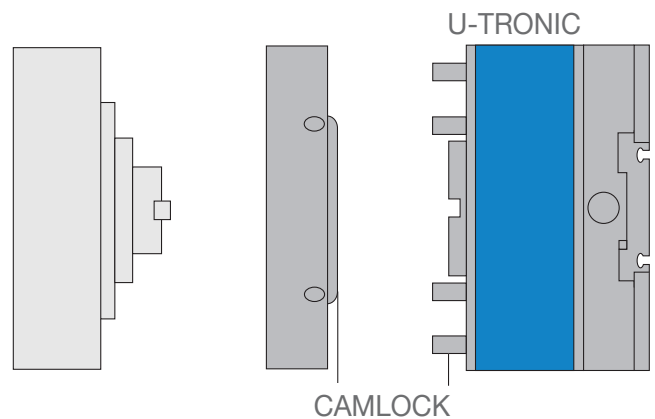
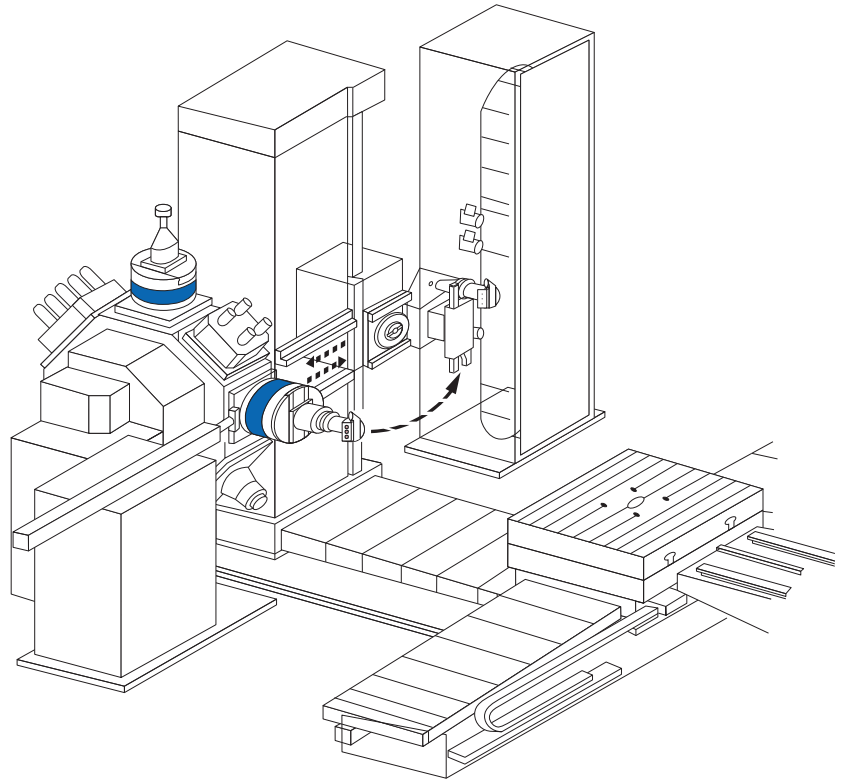
**E PREDISPOSICIONES.** Los cabezales U-TRONIC están predisuestos con agujeros para el paso del líquido refrigerante. Además es posible introducir a través de los agujeros predisuestos sobre el cuerpo fijo, aire para presurizar la zona motor y final de carrera, engrasar en automático el cinematismo interior y lubricar con aceite nebulizado las guías desplazamiento del carro y del husillo.

**F CARACTÉRISTIQUES.** Les têtes U-TRONIC sont munies d'orifices pour le passage du liquide réfrigérant. Il est en outre possible d'introduire de l'air par les orifices présents sur le corps fixe afin de pressuriser la zone moteur et la fin de course, graisser en automatique le cinematisme interne et lubrifier avec de l'huile nébulisée le coulisseau et la vis mère.

**I PREDISPOSIZIONI.** Le Teste U-TRONIC sono predisposte con dei fori per il passaggio del liquido refrigerante. Inoltre è possibile immettere dai fori predisposti sul corpo fisso, aria per pressurizzare la zona motore e finecorsa, ingrassare in automatico il cinematismo interno e lubrificare con olio nebulizzato le guide di scorrimento della slitta e la vite madre.



- APPLICATION
- ANBRINGUNG
- APLICACIÓN
- APPLICATION
- APPLICAZIONI



**GB** U-TRONIC is applied manually or automatically using a flange for fastening to the machine tool and a plate for the rotation of the rotating body. It is applied manually using a flange for fastening with a cam lock quick coupling, or automatically with a palletized system and special connectors. U-TRONIC can also be fitted with an automatic tool change toolholder changer of the tool mounted on the slide to obtain total automation.

**D** U-TRONICS können manuell oder automatisch mittels eines Befestigungsflansches oder einer Scheibe für die Drehung des Drehkörpers an die Werkzeugmaschine, angebracht werden. Diese werden manuell mittels Befestigungsflansch mit Camlock Schnellanschluss, oder automatisch durch Palettiersysteme und eigens vorgesehene Anschlüsse angebracht. U-TRONIC können außerdem mit einer Werkzeughalterung und automatischem Wechsel des Werkzeuges auf dem Schlitten, zum Erhalt einer vollständigen Automatisierung, ausgestattet werden.

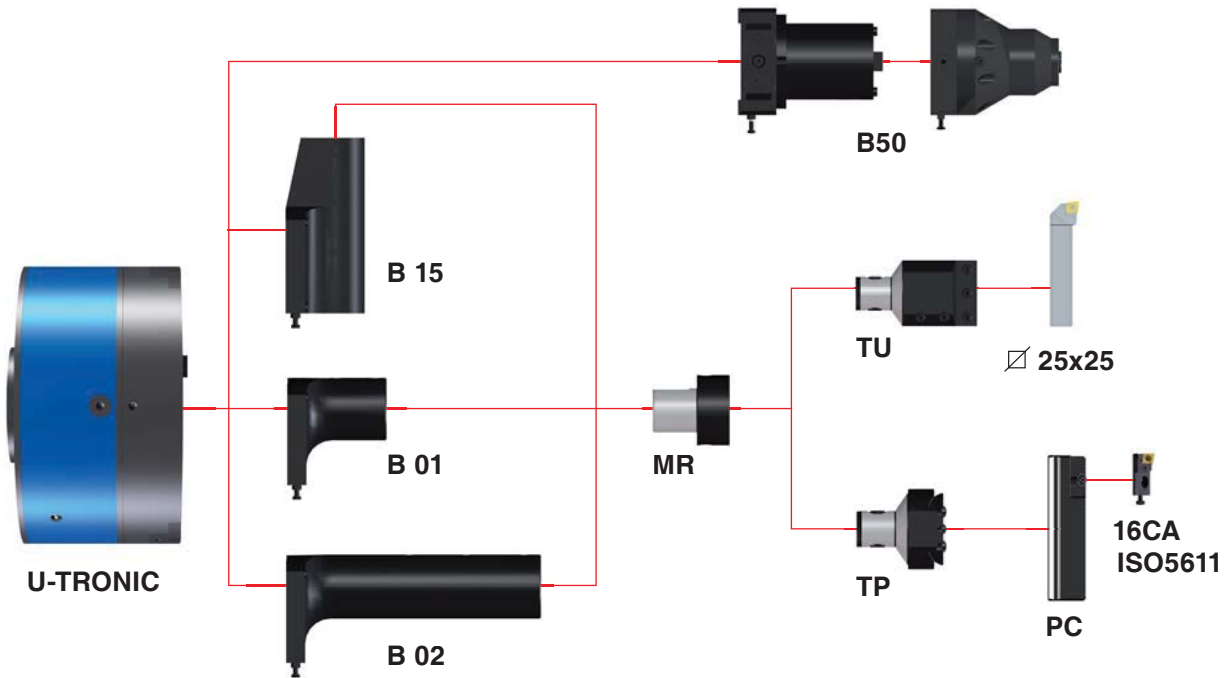
**E** Los U-TRONIC se aplican manual o automáticamente mediante una pletina para la fijación a la máquina herramienta y un plato para la rotación del cuerpo giratorio. Se aplican manualmente utilizando una abrazadera para la fijación con conexión rápida camlock, o automáticamente con sistemas paletizados y conectores al efecto. Además, los cabezales U-TRONIC pueden estar dotados de un portaherramienta de cambio automático de la herramienta montado en la corredera para obtener un automatismo total.

**F** Les U-TRONIC se montent manuellement ou automatiquement, à l'aide d'une bride pour la fixation à la machine outil, et d'un plateau pour la rotation du corps rotatif. Elles se montent manuellement en utilisant une bride pour la fixation rapide camlock ou automatiquement avec des systèmes palettisés et des connecteurs spéciaux. Les U-TRONIC peuvent également être équipées d'un porte-outil à changement automatique de l'outil, monté sur le coulisseau, afin d'obtenir une automatisation complète.

**I** Le U-TRONIC si applicano manualmente o automaticamente mediante una flangia per il fissaggio alla macchina utensile e un platorello per la rotazione del corpo rotante. Si applicano manualmente utilizzando una flangia per il fissaggio con attacco rapido camlock, o automaticamente con sistemi palletizzati e appositi connettori. Le U-TRONIC possono essere in oltre dotate di un portautensile a cambio automatico dell'utensile montato sulla slitta per ottenere una totale automazione.

- SUPPLY
- LIEFERUMFANG
- SUMINISTRO
- FOURNITURE
- FORNITURA

UT 3-360 / 5-500 / 5-630 / 5-800 / 8-800 / 8-1000 S



K03



- 1 B 01
- 1 B 02
- 1 B 15
- 1 MR
- 1 TU

REF.	CODE
KIT K03 UT 3-360 S	501703259300
KIT K03 UT 5-500 / 5-630 / 5-800 S	501705009300
KIT K03 UT 8-800 / 8-1000 S	501708009300

B50



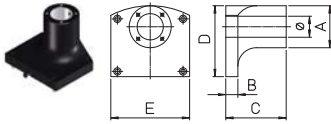
U-TRONIC	REF.
UT 3-360 S	B50 HSK - A63 -A100
UT 5-500 / UT 5-630 / 5-800 S	B50 DIN69871-A-B 50
UT 8-800 / 8-1000 S	B50 MAS BT50

- Special and HYDRAULICS B50 (fig.1) toolholders for automatic tool change, can be provided on request.
- Auf Anfrage sind spezielle und ÖLDYNAMISCHE (fig.1) Werkzeughalter B50, für automatische Wechsel des Werkzeuges lieferbar.
- Bajo pedido, se pueden suministrar portaherramientas B50 a cambio automatico de la herramienta, especiales y OLEODINAMICOS (fig.1).
- Porte-outils à changement automatique de l'outil B50 spéciaux et OLÉOHYDRAULIQUES (fig.1) sont fournis sur demande.
- A richiesta sono fornibili portautensili a cambio automatico dell'utensile B50, speciali e OLEODINAMICI (fig.1).



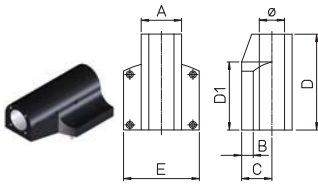
- ACCESSORIES
- ZUBEHÖRTEILE
- ACCESORIOS
- ACCESSOIRES
- ACCESSORI

## B01 / B02



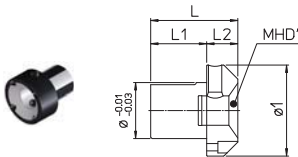
U-TRONIC	REF.	CODE	Ø <sub>H7</sub>	A	B	C	D	E	kg.
UT 3-360 S	B01	443005001150	50	80	23	100	135	150	5.5
	B02	443005002750				260			8.5
UT 5-500 / 5-630 / 5-800 S	B01	443006301550	63	100	30	155	170	200	11
	B02	443006303650				400			19
UT 8-800 / 8-1000 S	B01	443008002300	80	130		230	200	250	25
	B02	443008007200				720			60

## B15



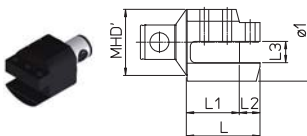
U-TRONIC	REF.	CODE	Ø <sub>H7</sub>	A	B	C	D	D1	E	Kg.
UT 3-360 S	B15	445005001900	50	80	23	60	190	135	150	3.7
UT 5-500 / 5-630 / 5-800 S		445006302500	63	100	30	70	270	170	200	7.5
UT 8-800 / 8-1000 S		445008003001	80	130		85	300	200	250	34

## MR



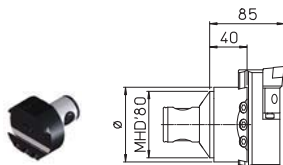
U-TRONIC	REF.	CODE	MHD'	Ø <sub>H7</sub>	Ø1	L	L1	L2	Kg.
UT 3-360 S	MR 50/80.80	450208001060	80	50	80	95	50	45	1.6
UT 5-500 / 5-630 / 5-800 S	MR 63/98.80	450209801060		63	98	105	60		3
UT 8-800 / 8-1000 S	MR 80/130.80	450213001240		80	130	125	80	6	
	MR 80/130.110	450213001340	110	80	185	105	9		

## TU



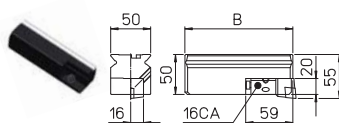
U-TRONIC	REF.	CODE	MHD'	Ø1	L	L1	L2	L3	Kg.
UT 3-360 S	TU 80/95.25	460508025001	80	95	90	65	25	32	4
UT 5-500 / 5-630 / 5-800 S									
UT 8-800 / 8-1000 S									

## TP



U-TRONIC	REF.	CODE	Ø	Kg.
UT 3-360 S	TP 80/90.50	460408050001	90	2.3
UT 5-500 / 5-630 / 5-800 S				
UT 8-800 / 8-1000 S	TP 80/125.50	460408050002	125	3.2

## PC



U-TRONIC	REF.	CODE	Ø	Kg.
UT 3-360 S	PC 11.50	433050160950	95	1.3
UT 5-500 / 5-630 / 5-800 S	PC 12.50	433050161350	135	2
	PC 13.50	433050162000	200	3.2
UT 8-800 / 8-1000 S	PC 14.50	433050163000	300	5

**PTGNL 16CA-16**

CODE 483010161001

**PCLNL 16CA-12**

CODE 483010161002

**PSSNL 16CA-12**

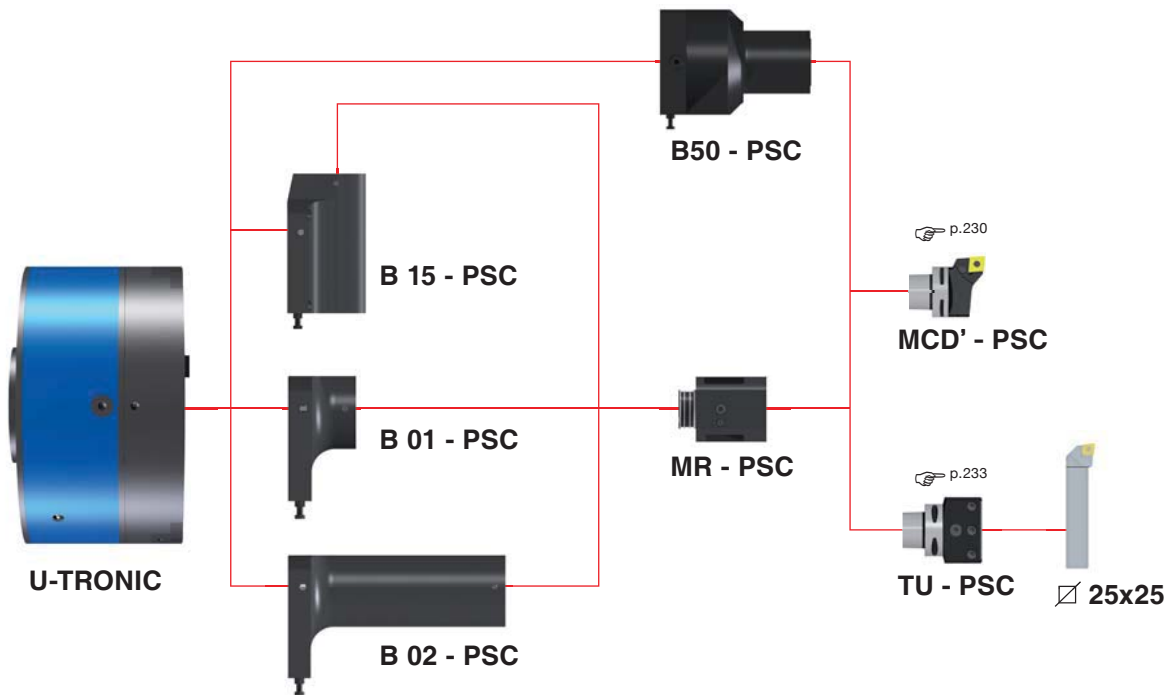
CODE 483010161003

**PSRNL 16CA-12**

CODE 483010161004



UT 3-360 / 5-500 / 5-630 / 5-800 / 8-800 / 8-1000 S



### K03 - PSC



1 B 01 - PSC  
1 B 02 - PSC  
1 B 15 - PSC  
1 MR - PSC

REF.	CODE
KIT K03 PSC 63 UT 3-360 S	501703259304
KIT K03 PSC 63 UT 5-500 / 5-630 / 5-800 S	501705009310
KIT K03 PSC 80 UT 5-500 / 5-630 / 5-800 S	501705009302
KIT K03 PSC 80 UT 8-800 / 8-1000 S	501708009301

### B50 - PSC



U-TRONIC	REF.
UT 3-360 S	B50 PSC 63-80
UT 5-500 / UT 5-630 / 5-800 S	
UT 8-800 / 8-1000 S	

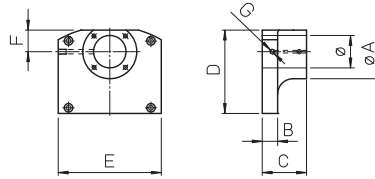
- Special and HYDRAULICS B50 toolholders for automatic tool change, can be provided on request.
- Auf Anfrage sind spezielle und ÖLDYNAMISCHE Werkzeughalter B50, für automatische Wechsel des Werkzeuges lieferbar.
- Bajo pedido, se pueden suministrar portaherramientas B50 a cambio automatico de la herramienta, especiales y OLEODINAMICOS.
- Porte-outils à changement automatique de l'outil B50 spéciaux et OLÉOHYDRAULIQUES sont fournis sur demande.
- A richiesta sono fornibili portautensili a cambio automatico dell'utensile B50, speciali e OLEODINAMICI.



- ACCESSORIES
- ZUBEHÖRTEILE
- ACCESORIOS
- ACCESSOIRES
- ACCESSORI

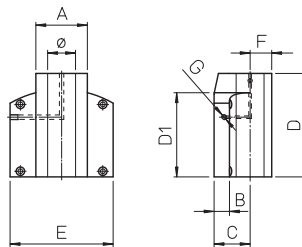
## PSC

### B01 / B02 - PSC



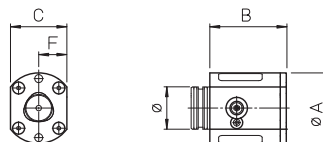
U-TRONIC	REF.	CODE	ØH7	A	B	C	D	E	F	G	kg.				
UT 3-360 S	<b>B01 - PSC 63</b>	443005000310	63	105	23	31	137	150	42	G1/8'	3.5				
	<b>B02 - PSC 63</b>	443005001610				161					10				
UT 5-500 / 5-630 / 5-800 S	<b>B01 - PSC 63</b>	443006302002			86	162	200	50			180	50	G1/4'	11	
	<b>B02 - PSC 63</b>	443006304452												331	20
	<b>B01 - PSC 80</b>	443006302001			71	185	10.5								
	<b>B02 - PSC 80</b>	443006304451			316	235	30								
UT 8-800 / 8-1000 S	<b>B01 - PSC 80</b>	443008001460	146	182	250	80	130		30	50				G1/4'	16
	<b>B02 - PSC 80</b>	443008006360													636

### B15 - PSC



U-TRONIC	REF.	CODE	ØH7	A	B	C	D	D1	E	F	G	Kg.
UT 3-360 S	<b>B15 - PSC 63</b>	445005001210	63	100	23	60	121	-	150	42	G1/8'	8
UT 5-500 / 5-630 / 5-800 S	<b>B15 - PSC 63</b>	445006303152			30	70	201	170	200			6.5
	UT 8-800 / 8-1000 S	<b>B15 - PSC 80</b>	445006303911	80	130	39	85	262	200	180	50	G 1/4'
<b>B15 - PSC 80</b>		445008003005	30			300	200	250	33			

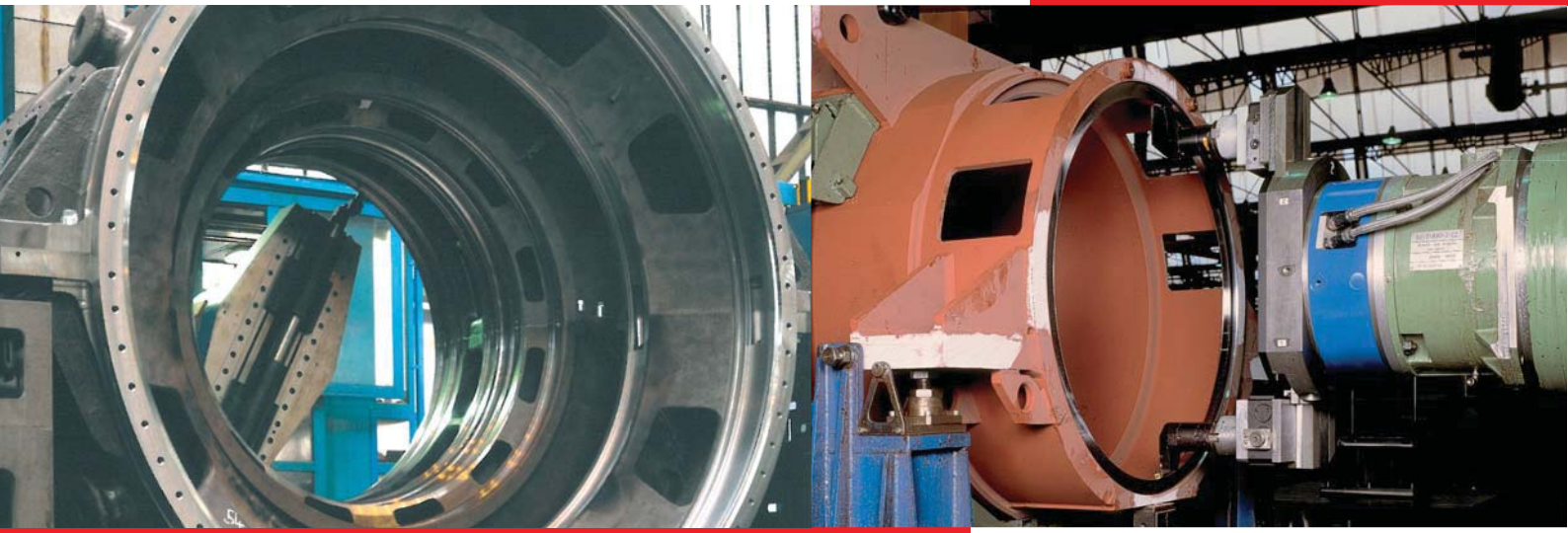
### MR - PSC



U-TRONIC	REF.	CODE	Øg6	A	B	C	F	Kg.
UT 3-360 S	<b>MR - PSC 63</b>	450206000630	63	105	114	84	42	6.5
UT 5-500 / 5-630 / 5-800 S								
UT 5-500 / 5-630 / 5-800 S	<b>MR - PSC 80</b>	450208000800	80	130	129	100	50	11
UT 8-800 / 8-1000 S								

**GB** There are two types of controls for U-TRONIC heads: - The first involves a direct connection to the "U" axis of the NC of the machine tool and allows for all types of cylindrical and conical boring, facing, threading, corner rounding and spherical operations to be performed. - The second involves the use of a simple U-CONTROL positioner with wireless REMOTE, which can be connected to the M functions of the machine to receive start signals of the different operations programmed on the REMOTE-CONTROL. This solution allows all types of turning, boring, facing, internal, external, threading, and conical operations to be performed **but spherical operations.**

**D** Zum Steuern der U-TRONIC-Köpfe gibt es zwei Möglichkeiten: - Die erste sieht den direkten Anschluss an die "U" Achse der numerischen Steuerung der Werkzeugmaschine vor und ermöglicht die Ausführung aller Arten von Drehbearbeitungen, Ausbohren, Innen- und Außenplanschleifen, Gewindebohrungen, Abrundungen und Rundbearbeitungen. - Die zweite sieht den Einsatz einer einfachen U-CONTROL Positioniervorrichtung mit wireless REMOTE vor, die an die M-Funktionen der Maschinensteuerung angeschlossen wird, um die Startsignale der verschiedenen, auf der REMOTE CONTROL programmierten Vorgänge zu empfangen. Diese Lösung ermöglicht die Ausführung aller Arten von Drehbearbeitungen, Ausbohren, Innen- und Außenplanschleifen, Gewindeschneiden und konische Bearbeitungen **aber keine Rundbearbeitung.**



266



CNC



**KIT U-CONTROL  
WIRELESS**

CODE : 55 0 020 100 001

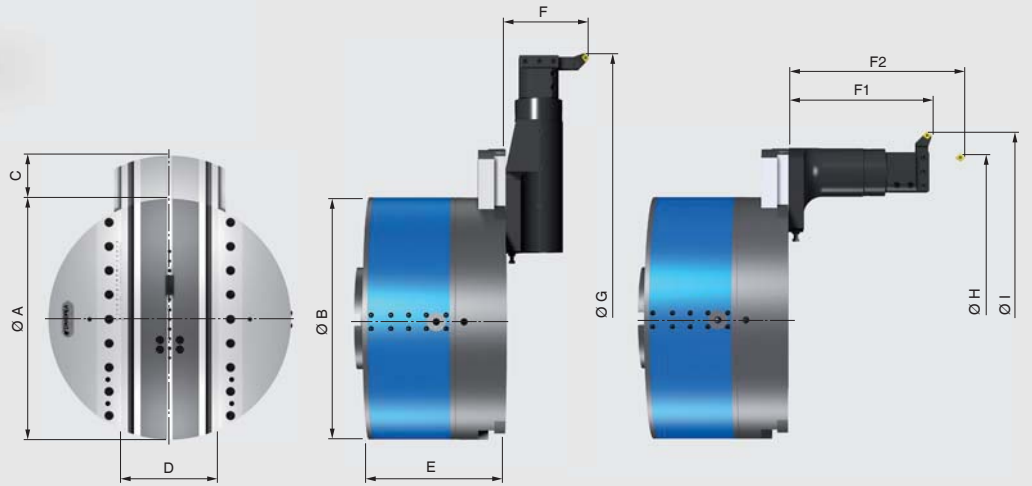
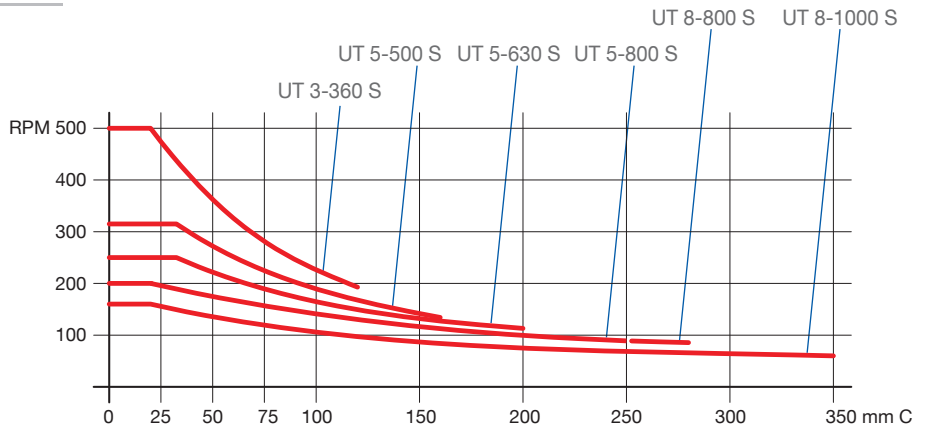
**E** Para el control de los cabezales U-TRONIC existen dos posibilidades: - La primera prevé la conexión directa al eje "U" del control numérico de la máquina herramienta y permite efectuar cualquier tipo de operación de torneado, mandrinados, refrentados internos y externos, roscados, radios y operaciones esféricas. - La segunda prevé el empleo de un simple posicionador U-CONTROL con REMOTE inalámbrico, que puede ser conectado a las funciones M del control de la máquina para recibir señales de start de las diferentes operaciones programadas en el REMOTE-CONTROL. Esta solución permite efectuar cualquier tipo de operación de torneado, mandrinados refrentados internos y externos, roscados y operaciones cónicas pero **no operaciones esféricas.**

**F** Deux possibilités existent pour la commande des têtes U-TRONIC: - La première prévoit le branchement direct à l'axe « U » de la commande numérique de la machine-outil et permet d'effectuer tous les types d'opération de tournage, alésage, dressage interne et externe, filetages, les rayons de courbure et les opérations sphériques. - La deuxième prévoit l'utilisation d'un simple positionneur U-CONTROL avec contrôle à distance sans fil qui peut être branché aux fonctions M de la commande de la machine pour recevoir les signaux de départ des différentes opérations programmées sur le contrôle à distance. Cette solution permet d'effectuer tous les types d'opération de tournage, alésage, dressage interne et externe, les filetages et les opérations coniques, **mais pas les opérations sphériques.**

**I** Per il comando delle teste U-Tronic esistono due possibilità: - La prima prevede il collegamento diretto all'asse "U" del controllo numerico della macchina utensile e permette di eseguire ogni tipo di operazione di tornitura, alesature, sfacciate interne, esterne, filettature, raggiature e operazioni sferiche. - La seconda prevede l'impiego di un semplice posizionatore U-CONTROL con REMOTE wireless, che può essere collegato alle funzioni M del controllo della macchina per ricevere segnali di start delle varie operazioni programmate sul REMOTE-CONTROL. Questa soluzione permette di eseguire ogni tipo di operazione di tornitura, alesature, sfacciate interne, esterne, filettature e operazioni coniche, **ma non operazioni sferiche.**



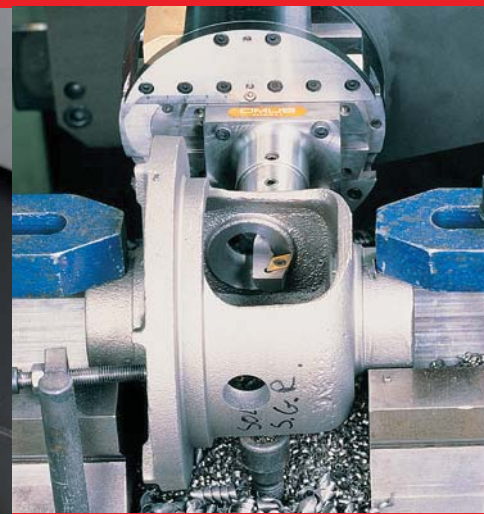
- TECHNICAL DATA
- TECHNISCHE DATEN
- DATOS TÉCNICOS
- DONNÉES TECHNIQUES
- DATI TECNICI



		UT 3-360 S	UT 5-500 S	UT 5-630 S	UT 5-800 S	UT 8-800 S	UT 8-1000 S
Ø A	mm	360	500	630	800		1000
Ø B	mm			500		800	
C • radial traverse • hub des werkzeugschlittens • carrera radial • course radiale • corsa radiale	mm	120	160	200	250	280	350
D	mm	154.6	199.6		230	250	260
E	mm	235	278.5	282	370	410	415
Ø G x F	mm	800 x 140	1000 x 150	1250 x 150	1400 x 150	1600 x 160	2000 x 160
Ø H x F2	mm	400 x 400	560 x 540	700 x 540	830 x 540	850 x 860	1050 x 860
Ø I x F1	mm	670 x 240	850 x 295	1050 x 295	1300 x 295	1250 x 370	1600 x 370
Max. mm/min	mm/min	1 ÷ 400				1 ÷ 500	
Max. ◊/min	RPM	500	315	250	200		160
• Weight • Gewicht • Peso • Poids • Peso	Kg	130	230	310	530	1000	1200
• Radial force • Vorschubkraft • Fuerza radial • Force radiale • Forza radiale	daN	400	500		1000		
• Torque • Drehmoment • Momento de torsión • Couple maxi • Momento torcente	daNm	400	800		1000		
• Boring accuracy • Bohrgenauigkeit • Precisión en mandrinado • Précision d'alésage • Precisione in alesatura		H7					
• Max chip removal • Max Materialabnahme • Max. arranque de viruta • Max du copeau • Max asportazione	mm <sup>2</sup> C40	5	9		14		
• Rapid traverse • Eilgang • Rápido • Rapide • Rapido	mm/min	400				500	
• Roughness • Rauigkeit • Rugosidad • Rugosità • Rugosità	Ra	0,8 ~ 1,2					



# D'ANDREA TA-CENTER



## *Turning operations on all machining centres*

**GB** TA-CENTER boring and facing heads are made to be used on automatic tool changers, therefore on essentially all machining centres. A U-Drive unit commands the feed control of the tool slide and the tool placement even during rotation. This unit is managed directly by an axle called "U" by the CNC of the machining centre. Organized in this way, the machining centre is the solution to a series of different processes like inner and outer turning operations, grooves, conical and variable boring, concave and convex radius machining, cylindrical and conical threading, complex profiles, and spherical operations.

**D** Die TA-CENTER Planbearbeitungs- und Ausdrehköpfe wurden für Maschinen mit automatischem Werkzeugwechsel entwickelt und eignen sich in Folge grundsätzlich für alle Bearbeitungszentren. Die Vorschubkontrolle des Werkzeughalters und der Werkzeugposition wird auch während der Rotation von einer motorbetriebenen U-DRIVE Gruppe gesteuert. Diese Gruppe wird direkt von einer „U“ genannten Achse der numerischen Steuerung des Bearbeitungszentrums verwaltet. Ein so gestaltetes Bearbeitungszentrum ermöglicht die Ausführung einer Reihe von verschiedenen Bearbeitungen, wie zum Beispiel das Innen- und Aussendrehen, Kerben, konische, auch variable Ausbohrungen, konkave und konvexe Radiusbearbeitungen, zylindrisches und konisches Gewindeschneiden, phonographische Spiralen usw. und Rundbearbeitungen.

**E** Los cabezales para refrentar y mandrinar TA-CENTER nacen para su empleo en máquinas con cambio automático de herramientas, es decir esencialmente e todos los centros de trabajo. El control del avance de la corredera portaherramienta y de la posición herramienta, incluso durante la rotación, están controlados, por un grupo de motorización U-DRIVE. Este grupo es gestionado directamente por un eje llamado "U" del control numérico del centro de trabajo. Un centro de trabajo preparado así, permitirá solucionar una serie de elaboraciones diferentes como torneado interno y externo, muescas, mandrinados cónicos incluso variables, radios cóncavos y convexos, roscas cilíndricas, espirales fonográficas, y operaciones esféricas.



- GENERAL FEATURES
- ALLGEMEINE MERKMALE
- CARACTERÍSTICAS GENERALES
- CARACTÉRISTIQUES GÉNÉRALES
- CARATTERISTICHE GENERALI



**F** Les têtes pour aléser et dresser TA CENTER sont conçues pour être utilisées sur des machines pour le changement d'outils en automatique, donc essentiellement sur les centres d'usinage. Le contrôle de l'avancement du coulisseau porte-outils et de la position de l'outil, même pendant la rotation, est commandé par un groupe de motorisation U-DRIVE. Ce groupe est géré directement par un axe appelé « U » de la commande numérique du centre d'usinage. Un centre d'usinage prédisposé de cette façon, permettra de résoudre une série d'usinages différents tels que le tournage intérieur et extérieur, les cannelures, les alésages coniques même variables, les rayons de courbure concaves et convexes, les filetages cylindriques et coniques, les spirales phonographiques, et les opérations sphériques.

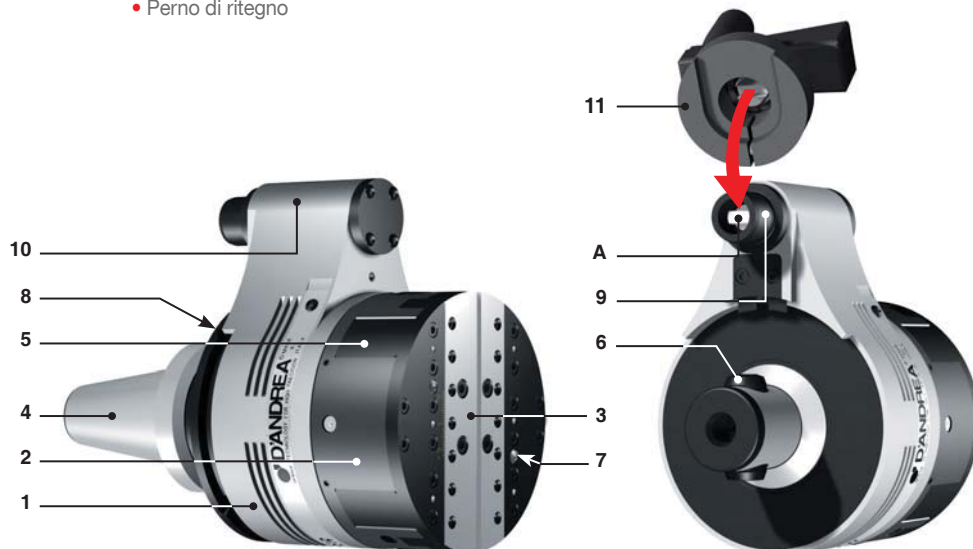
**I** Le teste per alesare e sfacciare TA-CENTER nascono per essere impiegate su macchine con cambio utensili automatico, dunque essenzialmente su tutti i centri di lavoro. Il controllo dell'avanzamento, della slitta portautensili e della posizione utensile, anche durante la rotazione, è comandato da un gruppo di motorizzazione U-DRIVE. Questo gruppo viene gestito direttamente da un asse chiamato "U" del controllo numerico del centro di lavoro. Un centro di lavoro così predisposto permetterà di risolvere una serie di lavorazioni differenti come tornitura interna ed esterna, canalini, alesature coniche anche variabili, raggiature concave e convesse, filettature cilindriche e coniche, spirali fonografiche e operazioni sferiche.

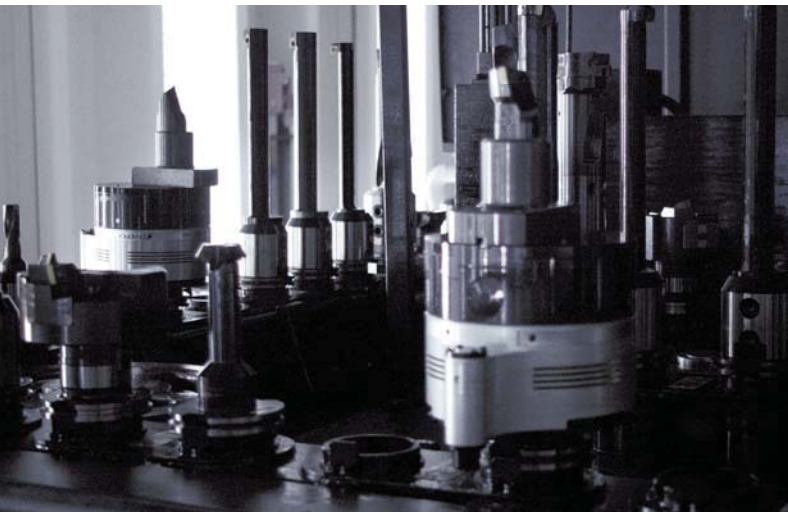


# D'ANDREA TA-CENTER

- COMPONENTS
- KOMPONENTEN
- COMPONENTES
- COMPOSANTS
- COMPONENTI

- 1 • Fixed body  
• Fixkörper  
• Cuerpo fijo  
• Corps fixe  
• Corpo fisso
- 2 • Rotating body  
• Rotierender Körper  
• Cuerpo giratorio  
• Corps rotatif  
• Corpo rotante
- 3 • Toolholder slide  
• Werkzeughalterschlitten  
• Corredera portaherramientas  
• Coulisseau porte-outils  
• Slitta portautensili
- 4 • Interchangeable taper  
• Austauschbarer Konus  
• Cono intercambiable  
• Cône interchangeable  
• Cono intercambiabile
- 5 • Balancing counter-weights  
• Ausgleichgegengewichte  
• Contrapesos de equilibrado  
• Contre-poids d'équilibrage  
• Contrappesi di equilibratura
- 6 • MHD' coupling  
• MHD' kupplung  
• Acoplamiento MHD'  
• Accouplement MHD'  
• Attacco MHD'
- 7 • Coolant liquid outlet nozzle  
• Kühlmittelaustritt  
• Orificios de salida del líquido refrigerante  
• Buses de sortie du liquide de lubrification et réfrigérant  
• Ugelli di uscita del liquido lubro-refrigerante
- 8 • Orientation ring  
• Orientierungsring  
• Anillo de orientación  
• Anneau d'orientation  
• Anello di orientamento
- 9 • Retaining pin  
• Rückhaltebolzen  
• Perno de retención  
• Goujon de retenue  
• Perno di ritegno
- 10 • "A" Drive  
• Lauf Anschluss „A“  
• Toma de movimiento «A»  
• Prise de mouvement «A»  
• Presa di moto 'A'
- 11 • Manual rotation device  
• Manuelle Rotierungsvorrichtung  
• Dispositivo de rotación manual  
• Dispositif de rotation manuel  
• Dispositivo di rotazione manuale





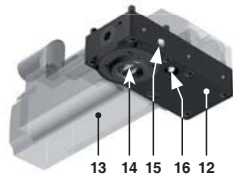
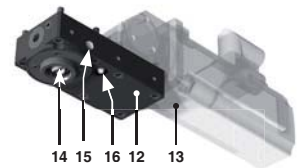
- 12** • Base element
- Basiskörper
  - Cuerpo base
  - Corps de base
  - Corpo base

- 13** • Servomotor
- Servomotor
  - Servomotor
  - Servomoteur
  - Servomotore

- 14** • Mechanical unit for automatic hook-up to the TA-CENTER drive
- Mechanische Antriebsgruppe zur automatischen Kupplung des TA-CENTER Lauf Anschlusses
  - Grupo mecánico para el acoplamiento automático a la toma de movimiento del TA-CENTER
  - Groupe mécanique pour l'accrochage automatique à la prise de mouvement de la TA-CENTER
  - Gruppo meccanico per il collegamento alla presa di moto della TA-CENTER

- 15** • The unit comes with air inlet connection for cleaning the drive
- Die Gruppe ist mit einem Luft Eintrittsanschluss zur Reinigung des Lauf Anschlusses, ausgestattet
  - El grupo está predispuesto con entrada de aire para la limpieza de la toma de movimiento
  - Le groupe est prédisposé avec une prise d'entrée d'air pour le nettoyage de la prise de mouvement
  - Predisposizione attacco entrata aria per pulizia della presa di moto

- 16** • Manual lubrication
- Manuelle Schmiervorrichtung
  - Engrasador manual
  - Graisseur manuel
  - Ingrassatore manuale



- **U-DRIVE COMMAND UNIT**
- **STEUERUNGSEINHEIT U-DRIVE**
- **UNIDAD DE MANDO U-DRIVE**
- **UNITÉ DE COMMANDE U-DRIVE**
- **UNITÀ DI COMANDO U-DRIVE**

**BB** The U-DRIVE drive unit must be mounted on the machining centre in a proper position next to the spindle so to ensure the mechanical connection to the TA-CENTER head drive.

**D** Die U-DRIVE Motorisierungsgruppe muss auf das Bearbeitungszentrum in geeigneter Position, neben der Spindel montiert werden, um die mechanische Verbindung des Lauf Anschlusses mit dem TA-CENTER Kopf zu sichern.

**E** El grupo de motorización U-DRIVE ha de estar montado en el centro de mecanizado en una posición adecuada al lado del husillo a fin de asegurar la conexión mecánica de la toma de movimiento con el cabezal TA-CENTER.

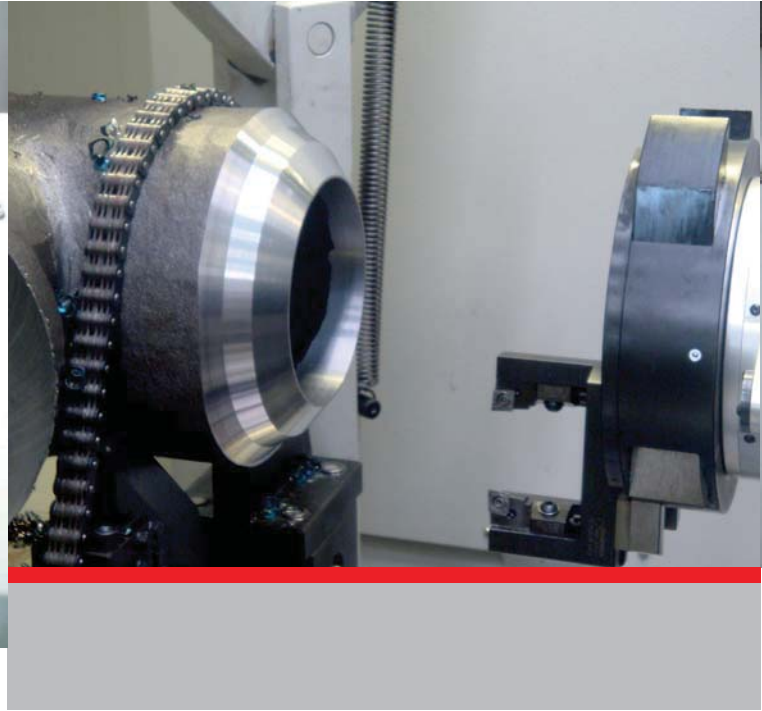
**F** Le groupe de motorisation U-DRIVE doit être monté sur le centre d'usinage, dans une position appropriée près de la broche, pour garantir la liaison mécanique de la prise de mouvement avec la tête TA-CENTER.

**I** Il gruppo U-DRIVE deve essere montato sul centro di lavoro in una posizione adeguata accanto al mandrino in modo da assicurare il collegamento meccanico con la testa TA-CENTER.



# D'ANDREA TA-CENTER

- APPLICATION
- ANBRINGUNG
- APLICACIÓN
- APPLICATION
- APPLICAZIONI



272

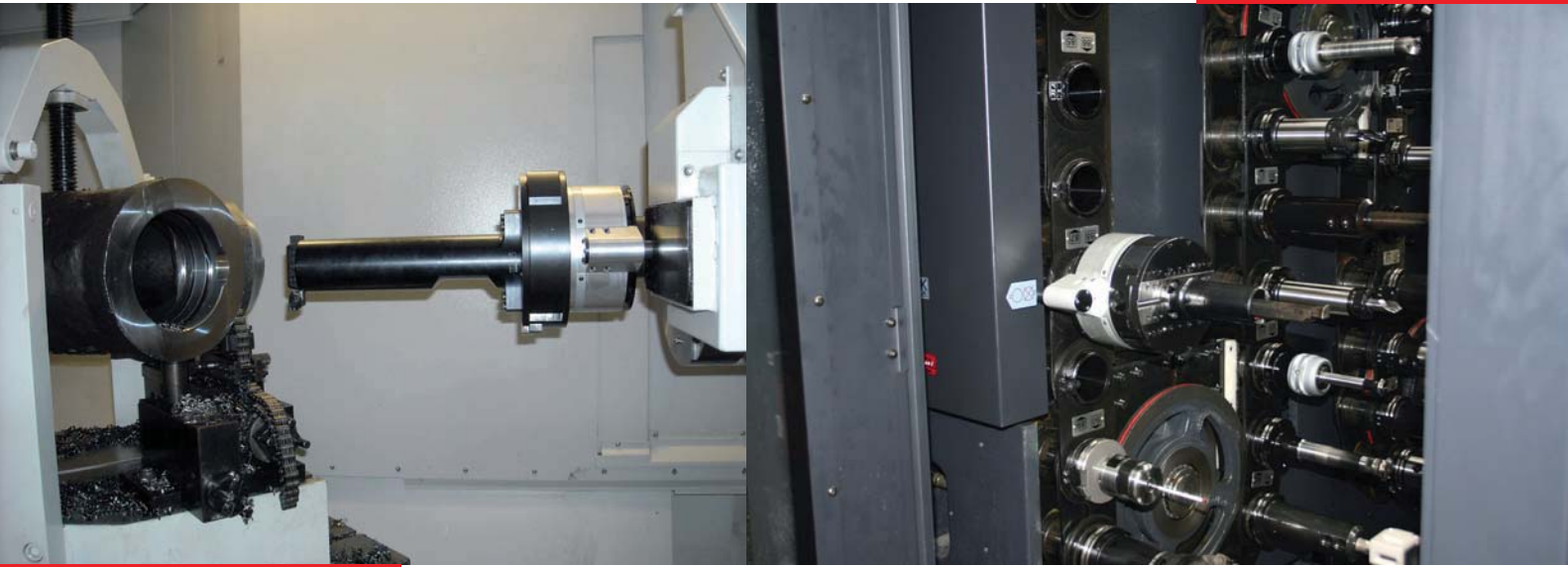




**B** Any application on machines that do not permit the connection to an axis of the NC, may be made by managing the motor of the U-DRIVE with a practical, simple, and economical U-CONTROL positioner with wireless REMOTE-CONTROL. The positioner can be connected to the M functions of the machine to receive start signals of the various operations programmed on the REMOTE-CONTROL. **Spherical machining is not possible with machines equipped with the U-CONTROL WIRELESS KIT.**

**D** Die eventuelle Anbringung auf Maschinen, die keinen Anschluss an eine CNC Achse ermöglichen, kann durch Verwaltung des Motors der Antriebsgruppe U-DRIVE mit einer praktischen, einfachen und preiswerten U-CONTROL Positioniervorrichtung mit wireless REMOTE-CONTROL erfolgen. Die Positioniervorrichtung kann an die M Funktionen der Maschinensteuerung zum Erhalt der Startsignale der verschiedenen in der REMOTE-CONTROL programmierten Ausführungen angeschlossen werden. **Auf mit U-CONTROL WIRELESS ausgestatteten Maschinen können keine Rundbearbeitungen ausgeführt werden.**

**E** La eventual aplicación en máquinas que no permiten la conexión a un eje del CNC, se puede realizar gestionando el motor del grupo de motorización U-DRIVE con un práctico, simple y económico posicionador U-CONTROL con REMOTE-CONTROL wireless. El posicionador se puede conectar a las funciones M del control de la máquina para recibir señales de start de las diferentes operaciones programadas en el REMOTE-CONTROL. **En las máquinas equipadas con el KIT U-CONTROL WIRELESS no es posible efectuar elaboraciones esféricas.**



CNC



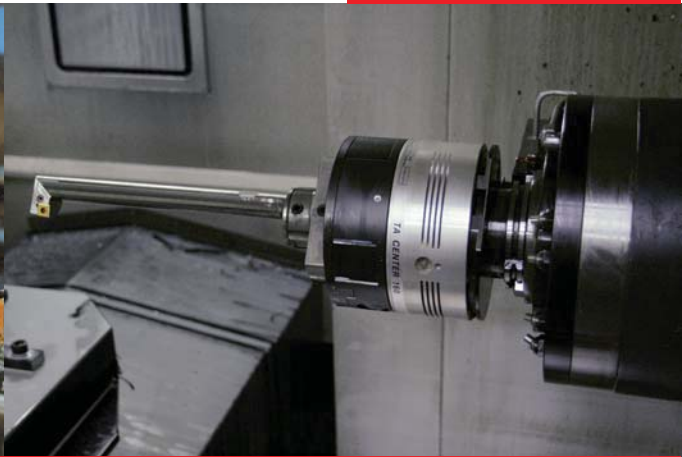
KIT U-CONTROL WIRELESS



**F** Les éventuelles applications sur les machines qui ne permettent pas le branchement à un axe de la commande numérique peuvent être réalisées en gérant le moteur du groupe de motorisation U-DRIVE avec un positionneur simple, pratique et économique U-CONTROL avec commande à distance sans fil (REMOTE CONTROL). Le positionneur peut être branché aux fonctions M de commande de la machine pour recevoir des signaux de démarrage des différentes opérations programmées sur la commande à distance. **Il n'est pas possible d'effectuer des usinages sphériques sur les machines équipées du kit U-CONTROL sans fil.**

**I** L'eventuale applicazione su macchina che non permettono il collegamento ad un asse del CNC, può essere fatta gestendo il motore del gruppo di motorizzazione U-DRIVE con un pratico, semplice ed economico posizionatore U-CONTROL con REMOTE-CONTROL wireless. Il posizionatore può essere collegato alle funzioni M del controllo della macchina per ricevere segnali di start delle varie operazioni programmate sul REMOTE-CONTROL. **Con le macchine equipaggiate con il KIT U-CONTROL WIRELESS non è possibile eseguire lavorazioni sferiche.**

# D'ANDREA TA-CENTER



- **BALANCING AND COOLANT SUPPLY**
- **AUSGLEICH ZUFÜHRUNG DES KÜHLMITTELS**
- **EQUILIBRADO Y PASO DEL LÍQUIDO REFRIGERANTE**
- **ÉQUILIBRAGE ET AMENÉE DE LIQUIDE RÉFRIGÉRANT**
- **BILANCIATURA E ADDUZIONE LIQUIDO REFRIGERANTE**



**B** TA-CENTER heads are designed with two counter-weights for automatic balancing, that move opposite to the slide. Coolant exits from the two adjustable nozzles in the TA-CENTER located next to the slide after crossing the taper and the rotating body of the head.

**D** Die TA-CENTER Köpfe wurden mit zwei Gegengewichten zum automatischen Ausgleich entwickelt, sie bewegen sich in die entgegengesetzte Richtung zum Schlitten. In den TA-CENTER fließt das Kühlmittel nach Durchfluss durch den Konus und den Rotierkörper des Kopfes, aus zwei orientierbaren Düsen an der Seite des Schlittens.

**E** Los cabezales TA-CENTER se han diseñado con dos contrapesos para el equilibrado automático, que se mueven en sentido contrario a la corredera. En los TA-CENTER el líquido refrigerante sale por dos boquillas orientables situadas al lado de la corredera después de haber atravesado el cono y el cuerpo giratorio del cabezal.

**F** Les têtes TA-CENTER ont été conçues avec deux contrepoids pour l'équilibrage automatique. Ils se déplacent dans le sens contraire par rapport au coulisseau. Dans les TA-CENTER, le liquide réfrigérant sort de deux buses orientables placées à côté du coulisseau, après avoir traversé le cône et le corps rotatif de la tête.

**I** Le teste TA-CENTER sono state progettate con due contrappesi per il bilanciamento automatico, che si muovono in senso opposto alla slitta. Nelle TA-CENTER il liquido refrigerante esce da due ugelli orientabili posti a fianco della slitta dopo aver attraversato il cono ed il corpo rotante della testa.





- SUPPLY
- LIEFERUMFANG
- SUMINISTRO
- FOURNITURE
- FORNITURA

## K02



REF.	CODE
K02 TA-C 80 I.65	501250800650
K02 TA-C 80 I.80	501250800800
K02 TA-C 100 I.80	501251000800
K02 TA-C 100 I.110	501251001100
K02 TA-C 125 I.80	501251250800
K02 TA-C 125 I.110	501251251100
K02 TA-C 160 I.110	501251601100
K02 TA-C 200 I.110	501252001100

## K03

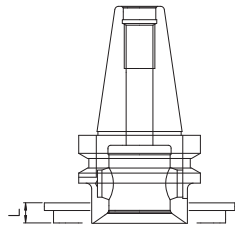


1 P120 1 P130

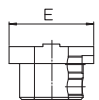
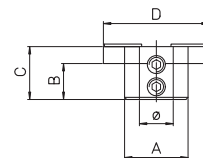
REF.	CODE
KIT K03 TA-C 80	501200300801
KIT K03 TA-C 100-125	501200301001
KIT K03 TA-C 160-200	501200301601

- Complete range of cones on page 17 • Komplette Konusreihe auf Seite 17 • Gama completa de los conos en la pág. 17  
 • Gamme complète des cônes à la page 17 • Gamma completa dei coni a pag. 17

## MHD'

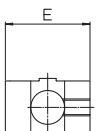
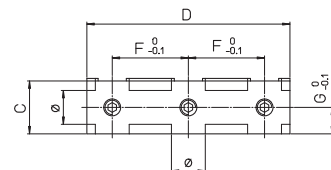


REF.	MHD'	L
TA-C 80	40	10,5
TA-C 100-125	50	11,5
TA-C 160-200	80	



## P120

	REF.	CODE	ØH7	A	B	C	D	E	Kg.
TA-C 80	P120	431550160200	16	30	14	20	40	32	0.1
TA-C 100-125		431550160250			17	25	50	40	0.2
TA-C 160-200		431550250380	25	47	27.5	38	76	54	0.55

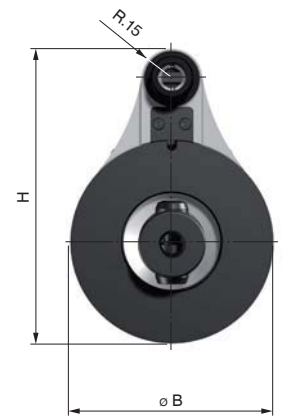
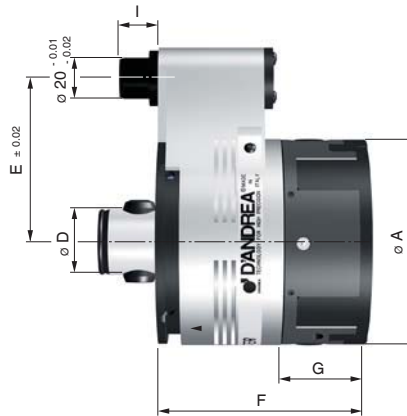
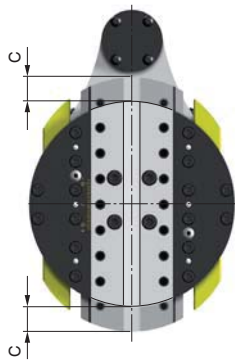
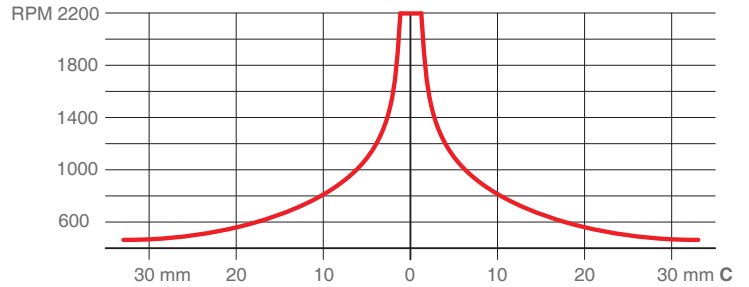


## P130

	REF.	CODE	ØH7	C	D	E	F	G	Kg.
TA-C 80	P130	433032200800	16	20	80	32	30	10.5	0.3
TA-C 100-125		433040250950		25	95	40	37		0.5
TA-C 160-200		433054381520	25	38	152	54	59.5	16.5	1.6



- TECHNICAL DATA
- TECHNISCHE DATEN
- DATOS TECNICOS
- DONNÉES TECHNIQUES
- DATI TECNICI



		TA-C 80	TA-C 100	TA-C 125	TA-C 160	TA-C 200
Ø A	mm	80	100	125	160	200
Ø B	mm	80.5	100.5	160.5		
C	mm	± 10	± 12	± 17	± 25	± 32.5
		<ul style="list-style-type: none"> <li>• radial traverse • hub des werkeugschlittens • carrera radial</li> <li>• course radiale • corsa radiale</li> </ul>				
Ø D	mm	(MHD'40) 25 <sup>-0.004</sup> / <sub>-0.006</sub>	(MHD'50) 32 <sup>-0.005</sup> / <sub>-0.008</sub>	(MHD'80) 42 <sup>-0.005</sup> / <sub>-0.008</sub>		
E	mm	65/80	80/110	110		
F	mm	81	100	104	136	
G	mm	33.2	40.5	44.5	56	
H	mm	120 / 135	145 / 175	205		
I	mm	17	19			
Ø L	mm	8 ~ 62	10 ~ 72	10 ~ 81	20 ~ 109	20 ~ 124
M	mm	60	75		125	
Ø N	mm	62 ~ 102	72 ~ 122	63 ~ 131	103 ~ 203	88 ~ 218
O	mm	80	100		160	
Ø P	mm	112 ~ 160	122 ~ 200	131 ~ 250	203 ~ 320	218 ~ 400
Q	mm	20.5	25.5		38.5	
Max. mm/min	mm/min	1 ÷ 500				
Max. ◊/min	RPM	2200	2000	1800	1600	1400
• Weight without the cone • Gewicht ohne Konus • Peso sin cono	Kg	2.5	4.8	6.5	16.8	21.4
• Poids sans cône • Peso senza cono						
• Radial force • Vorschubkraft • Fuerza radial	daN	100	150		250	
• Force radiale • Forza radiale						
• Torque • Drehmoment • Momento de torsión	Nm	200	400		800	
• Couple maxi • Momento torcente						
• Boring accuracy • Bohrgenauigkeit • Precisión en mandrinado		H7				
• Précision d'alésage • Precisione in alesatura						
• Max chip removal • Max Materialabnahme • Max. arranque de viruta	mm <sup>2</sup> C40	0,5	0,75	0,85	1	
• Max du copeau • Max asportazione						
• Roughness • Rauigkeit • Rugosidad	Ra	0,8 ~ 1,2				
• Rugosità • Rugosità						



## Turning operations on all machine tools



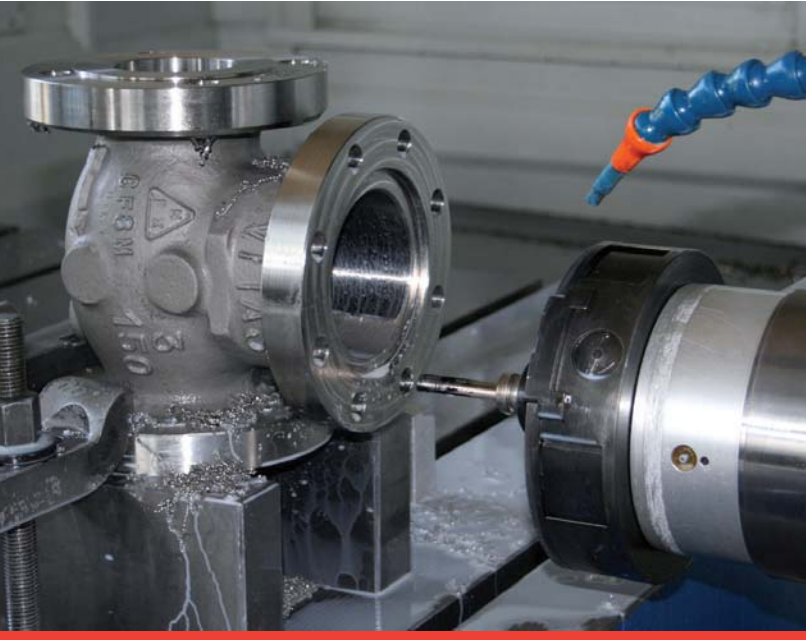
**GB** TA-Tronic boring and facing heads can be manually or automatically applied on small boring machines, machining centres and special machines. Connection with the machine tool spindle occurs through a cone for the rotation of the rotating head and a flange for fastening the fixed body on to the fixed part of the machine. For lighter tasks a simple anti-rotation pin may be used.

**D** Die Ausbohr- und Planbearbeitungsköpfe TA-Tronic werden manuell oder automatisch auf kleinen Bohrmaschinen, Arbeitszentren und Spezialmaschinen angebracht. Die Verbindung mit der Spindel der Werkzeugmaschine erfolgt durch einen Konus zur Rotation des Rotationskörpers und einem Flansch zum Befestigen des festen Körpers am festen Teil der Maschine. Für nicht anspruchsvolle Bearbeitungen kann ein einfacher Rotationsverhindernder Bolzen verwendet werden.

**E** Los cabezales para mandrinar y refrentar TA-Tronic se aplican manual o automáticamente en pequeñas mandrinadoras, centros de trabajo y máquinas especiales. La conexión con el husillo de la máquina-herramienta se realiza mediante un cono para la rotación del cuerpo giratorio y una brida para la fijación del cuerpo fijo en la parte fija de la máquina. Para operaciones poco pesadas es posible usar un simple perno de antirotación.



- GENERAL FEATURES
- ALLGEMEINE MERKMALE
- CARACTERÍSTICAS GENERALES
- CARACTÉRISTIQUES GÉNÉRALES
- CARATTERISTICHE GENERALI



**F** Les têtes pour aléser et dresser TA-Tronic se montent manuellement ou automatiquement sur de petites aléseuses, des centres d'usinage et des machines spéciales. La liaison avec la broche de la machine outil se produit par le biais d'un cône pour la rotation du corps rotatif et d'une bride pour la fixation du corps fixe sur la partie fixe de la machine. Pour des opérations peu lourdes, il est possible d'utiliser un simple pivot anti-rotation.

**I** Le teste per alesare e sfacciare TA-Tronic si applicano manualmente o automaticamente su piccole alesatrici, centri di lavoro e macchine speciali. Il collegamento con il mandrino della macchina utensile avviene mediante un cono per la rotazione del corpo rotante e una flangia per il fissaggio del corpo fisso sulla parte fissa della macchina. Per operazioni poco gravose è possibile usare un semplice perno antirotazione.





- 1**
- Fixed body
  - Fixkörper
  - Cuerpo fijo
  - Corps fixe
  - Corpo fisso

- 2**
- Rotating body
  - Rotierender Körper
  - Cuerpo giratorio
  - Corps rotatif
  - Corpo rotante

- 3**
- Toolholder slide
  - Werkzeughalterschlitzen
  - Corredera portaherramientas
  - Coulisseau porte-outils
  - Slitta portautensili

- 4**
- Interchangeable taper
  - Austauschbarer Konus
  - Cono intercambiable
  - Cône interchangeable
  - Cono intercambiabile

- 5**
- Balancing counter-weights
  - Ausgleichgegengewichte
  - Contrapesos de equilibrado
  - Contre-poids d'équilibrage
  - Contrappesi di equilibratura

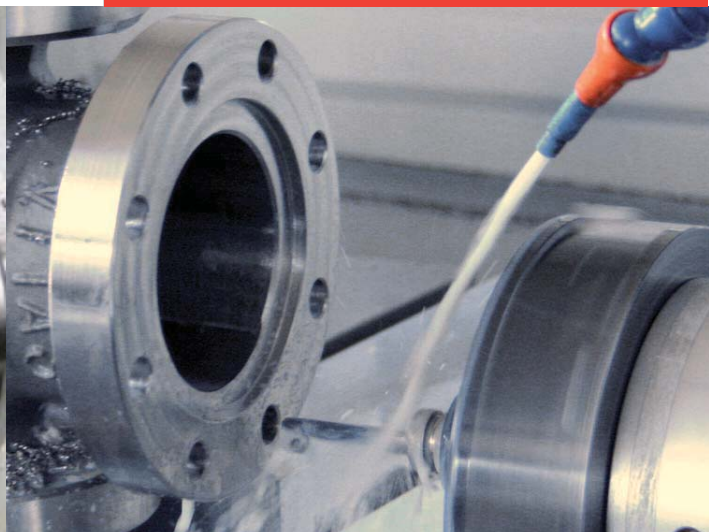
- 6**
- MHD' coupling
  - MHD' kupplung
  - Acoplamiento MHD'
  - Accouplement MHD'
  - Attacco MHD'

- 7**
- Coolant liquid outlet nozzle
  - Kühlmittelaustritt
  - Orificios de salida del líquido refrigerante
  - Buses de sortie du liquide de lubrification et réfrigérant
  - Ugelli di uscita del liquido lubro-refrigerante

- 8**
- Anti-rotation pin
  - Rotationsverhindernder Bolzen
  - Perno antirotación
  - Pivot antirotation
  - Perno antirotazione

- 9**
- Motor
  - Motor
  - Motor
  - Moteur
  - Motore

- 10**
- Anti-rotation Small block
  - Rotationsverhindernder Dübel
  - Bloque antirotación
  - Goujon antirotation
  - Tassello antirotazione



- COMMAND UNIT
- STEUERUNGSEINHEIT
- UNIDAD DE MANDO
- UNITÉ DE COMMANDE
- UNITÀ DI COMANDO

**GB** Two possibilities are available for the control unit of the TA-Tronic head: the first one involves a direct connection to the “U” axis of the NC in the machine tool which allows for boring, inner facing, outer facing, back – facing, grooving, complex profiles, threading and taper boring, taper and variable boring, concave and convex radius machining through the interpolation with the other axis. The second with a simple and economical U-CONTROL positioner with a wireless REMOTE-CONTROL. The positioner can be connected to the M function of the machine to receive start signals of the various operations programmed on the REMOTE-CONTROL. This solution allows for boring machining, inner facing, outer facing, back-facing, inner and outer turning operations, grooves, complex profiles, threading, and taper boring. **Spherical machining is not possible with machines equipped with the U-CONTROL WIRELESS KIT.**

**D** Für die Steuerung der TA-Tronic Köpfe bestehen zwei Möglichkeiten: die erste sieht die direkte Verbindung zur „U“ Achse der Nummernkontrolle der Werkzeugmaschine zur Ausführung von Bohrarbeiten, Innen – außen und Unterschnittplanbearbeitungen, innen – und Aussendrehen, Kerben und phonografische Spiralen, Gewindeschneiden und konische, auch variable Planbearbeitungen, sowie konkave und konvexe Radialbearbeitungen mittels Interpolation mit den anderen Achsen vor. Die zweite besteht aus einer einfachen und günstigen U-CONTROL Positioniereinrichtung mit REMOTE CONTROL wireless. Die Positioniereinrichtung kann an die M Funktionen der Maschinensteuerung zum Erhalt der Startsignale der verschiedenen, auf REMOTE-CONTROL programmierten Vorgänge, angeschlossen werden. Diese Lösung ermöglicht Bohrarbeiten, innen – und Aussendrehen, Kerben und phonografische Spiralen, sowie konisches Gewindeschneiden und Bohrarbeiten. **Auf mit U-CONTROL WIRELESS ausgestatteten Maschinen können keine Rundbearbeitungen ausgeführt werden.**

**E** Para el mando de los cabezales TA-Tronic existen dos posibilidades: la primera prevé la conexión directa al eje “U” del control numérico de la máquina herramienta que permite elaboraciones de mandrinado, refrentado interno, externo y corte en ángulo agudo, torneado interno y externo, muescas, espirales fonográficas, roscas y mandrinados cónicos, incluso variables, radios cóncavos y convexos mediante la interpolación con los otros ejes. La segunda con simple y económico posicionador U-CONTROL con REMOTE-CONTROL wireless. El posicionador puede estar conectado a las funciones M del control de la máquina para recibir señales de start de las varias operaciones programadas en el REMOTE-CONTROL. Esta solución permite elaboraciones de mandrinado, refrentado interno, externo y corte en ángulo agudo, torneado interno y externo, muescas, espirales fonográficas, roscas y mandrinados cónicos. **Con las máquinas equipadas con el KIT U-CONTROL WIRELESS no es posible efectuar elaboraciones esféricas.**

**F** Pour la commande des têtes TA-Tronic, deux possibilités sont disponibles: la première prévoit la liaison directe de l’axe « U » de la commande numérique de la machine outil qui permet les usinages d’alésage, de dressage interne, externe et contre-dépouille, de tournage interne et externe, de coulisses, de spirales phonographiques, de filetages et d’alésages cylindriques, d’alésages coniques même variables, de rayons de courbure concaves et convexes, à l’aide de l’interpolation avec les autres axes. La seconde avec un positionneur simple et économique U CONTROL avec contrôle à distance sans fil. Le positionneur peut être branché aux fonctions M de la commande de la machine, pour recevoir les signaux de départ des différentes opérations programmées sur le contrôle à distance. Cette solution permet des usinages d’alésage, de dressage interne, externe et contre-dépouille, de tournage interne et externe, de coulisses, de spirales phonographiques, de filetages et d’alésages coniques. **Il n’est pas possible d’effectuer des usinages sphériques avec les machines équipées du KIT U CONTROL sans fil.**

**I** Per il comando delle teste TA-Tronic esistono due possibilità: la prima prevede il collegamento diretto all’asse “U” del controllo numerico della macchina utensile che permette lavorazioni di alesatura, sfacciatura interna, esterna e sottosquadra, tornitura interna ed esterna, canalini, spirali fonografiche, filettature e alesature coniche, alesature coniche anche variabili, raggature concave e convesse mediante l’interpolazione con gli altri assi. La seconda con semplice ed economico posizionatore U-CONTROL con REMOTE-CONTROL wireless. Il posizionatore può essere collegato alle funzioni M del controllo della macchina per ricevere segnali di start delle varie operazioni programmate sul REMOTE-CONTROL. Questa soluzione permette lavorazioni di alesatura, sfacciatura interna, esterna e sottosquadra, tornitura interna ed esterna, canalini, spirali fonografiche, filettature e alesature coniche. **Con le macchine equipaggiate con il KIT U-CONTROL WIRELESS non è possibile eseguire lavorazioni sferiche.**



CNC



KIT U-CONTROL WIRELESS

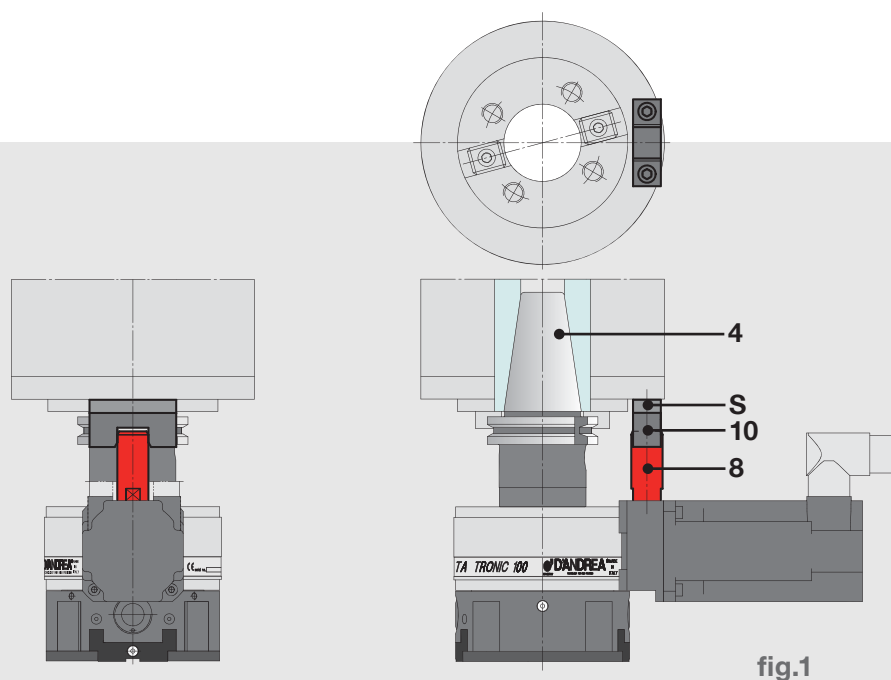
CODE : 55 0 020 100 001



# D'ANDREA TA-TRONIC

**GB** TA-TRONIC is mounted on the machine using a taper (4). The anti-rotation pin (8) inserted in the dowel (10) locked on the head of the machine tool, preventing the fixed body of TA-TRONIC to rotate. The dowel (10) is applied on a fixed part around the spindle fig. 1, adjusting the height indicated by way of a thickness S. For heavy machining it is advisable to apply a flange to make the TA-TRONIC solidly connected with the head of the machine tool (fig. 2-3). It is always advisable to use a flange with TA-TRONIC 160 and 200. The type of flange to use depends on the model of the machine and may be easily built by the Customer or supplied by D'Andrea.

**D** Die TA-TRONIC Vorrichtungen werden mittels Konus (4) an die Maschine angeschlossen. Der Rotationsverhindernde Bolzen (8), welcher in den, auf dem Kopf der Werkzeugmaschine befestigten Dübel (10) eingeführt ist, verhindert die Rotation des festen TA-TRONIC Körpers. Der Dübel (10) wird auf einen festen Teil rund um die Spindel, fig.1 und Einstellung der angegebenen Höhe mittels einer Distanzscheibe S, angebracht. Für schwerwiegende Arbeiten empfiehlt man das Anbringen eines Flansches zum konsolidieren des TA-TRONIC Kopfes mit dem Kopf der Werkzeugmaschine (fig. 2-3). Mit den TA-TRONIC Vorrichtungen 160 und 200 ist die Anwendung eines Flansches immer empfehlenswert. Die Art des zu verwendenden Flansches hängt vom Maschinenmodell ab und kann einfach vom Kunden selbst hergestellt, oder von D'Andrea geliefert werden.



- APPLICATION
- ANBRINGUNG
- APLICACIÓN
- APPLICATION
- APPLICAZIONI

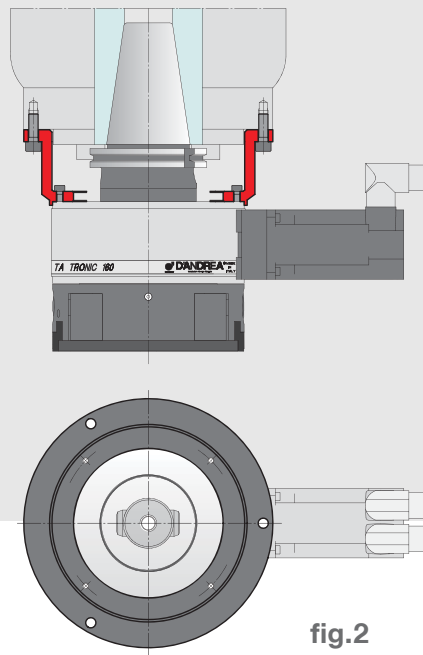
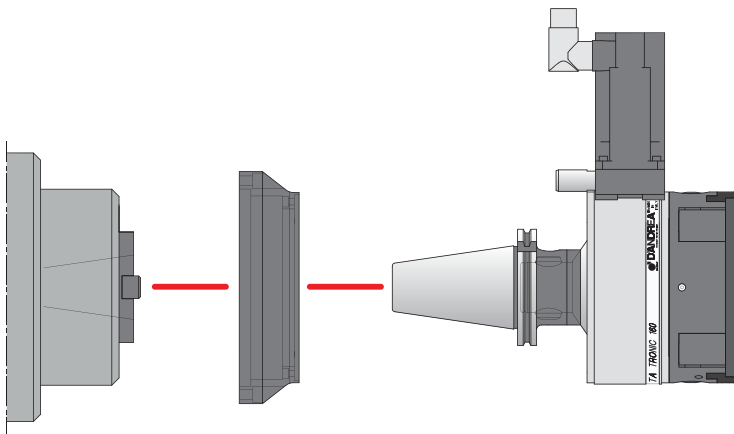


fig.2

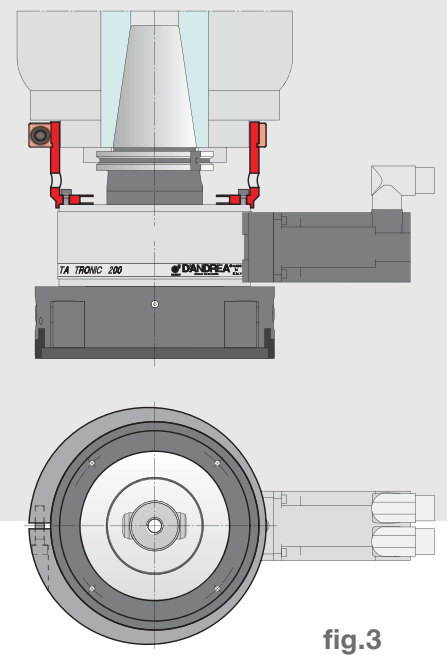


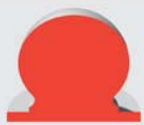
fig.3

**E** Los TA-TRONIC se montan en la máquina mediante el cono (4). El perno antirotación (8), introducido en el bloque antirotación (10) fijado en el cabezal de la máquina herramienta, impide la rotación del cuerpo fijo de la TA-TRONIC. El bloque ha de colocarse en una parte fija alrededor del husillo fig.1, regulando la altura indicada por medio de un espesor S. Para elaboraciones pesadas se aconseja aplicar una brida para reforzar la unión del TA-TRONIC con el cabezal de la máquina herramienta (fig. 2-3). En los TA-TRONIC 160 y 200 se aconseja siempre el uso de la brida. El tipo de brida depende del modelo de la máquina y puede ser fácilmente construida por el Cliente o suministrada por D'Andrea.

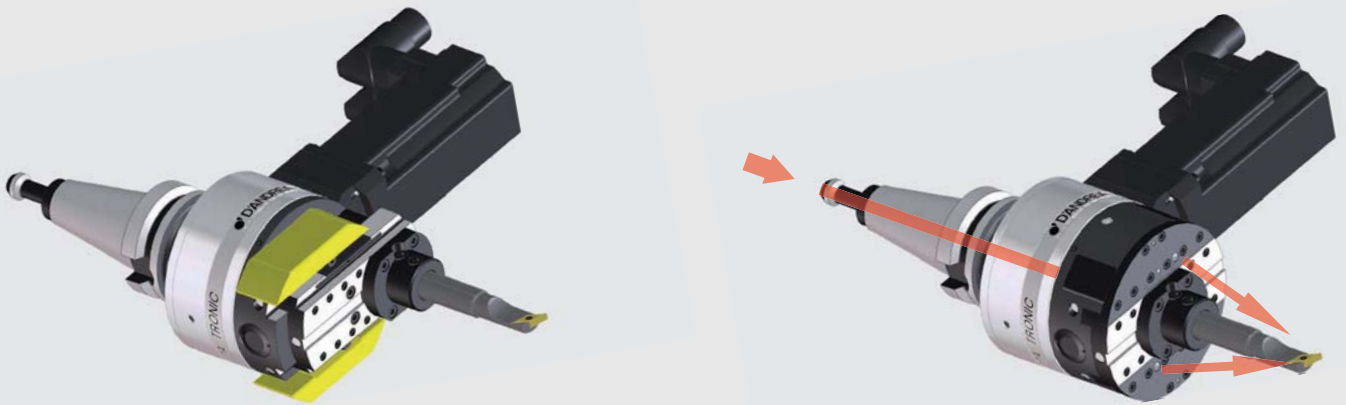
**F** Les TA-TRONIC sont montées sur la machine à l'aide du cône (4). Le pivot anti-rotation (8) inséré dans le tasseau (10) bloqué sur la tête de la machine outil, empêche la rotation du corps fixe de la TA-TRONIC. Le tasseau (10) doit être monté sur une partie fixe autour de la broche, figure 1, et en réglant la hauteur indiquée à l'aide de l'épaisseur S. Pour des usinages lourds, nous conseillons de monter une bride pour relier la TA-TRONIC à la tête de la machine outil (figure 2-3). Avec les TA-TRONIC 160 et 200, nous conseillons de toujours utiliser la bride. Le type de bride à utiliser dépend du modèle de la machine et peut être facilement fabriqué par le client ou fourni par D'Andrea.

**I** Le TA-TRONIC vengono montate sulla macchina mediante il cono (4). Il perno antirotazione (8), inserito nel tassello (10) bloccato sulla testa della macchina utensile, impedisce la rotazione del corpo fisso della TA-TRONIC. Il tassello (10) va applicato su una parte fissa attorno al mandrino fig.1, regolando l'altezza per mezzo di uno spessore S. Per lavorazioni gravose è consigliabile applicare una flangia per rendere solidale la TA-TRONIC con la testa della macchina utensile (fig. 2-3). Con le TA-TRONIC 160 e 200 è sempre consigliato l'uso della flangia. Il tipo di flangia da adottare dipende dal modello della macchina e può essere facilmente costruita dal Cliente o fornita da D'Andrea.

# D'ANDREA TA-TRONIC



- BALANCING AND COOLANT SUPPLY
- AUSGLEICH ZUFÜHRUNG DES KÜHLMITTELS
- EQUILIBRADO Y PASO DEL LÍQUIDO REFRIGERANTE
- ÉQUILIBRAGE ET AMENÉE DE LIQUIDE RÉFRIGÉRANT
- BILANCIATURA E ADDUZIONE LIQUIDO REFRIGERANTE



**B** TA-TRONIC heads are designed with two counter-weights for automatic balancing, that move opposite to the slide. Coolant exits from the two adjustable nozzles in the TA-TRONIC located next to the slide after crossing the taper and the rotating body of the head.

**D** Die TA-TRONIC Köpfe wurden mit zwei Gegengewichten zum automatischen Ausgleich entwickelt, sie bewegen sich in entgegengesetzte Richtung zum Schlitten. In den TA-TRONIC fließt das Kühlmittel nach Durchfluss durch den Konus und den Rotierkörper des Kopfes aus zwei orientierbaren Düsen an der Seite des Schlittens.

**E** Los cabezales TA-TRONIC se han diseñado con dos contrapesos para el equilibrado automático, que se mueven en sentido contrario a la corredera. En los TA-TRONIC el líquido refrigerante sale por dos boquillas orientables situadas al lado de la corredera después de haber atravesado el cono y el cuerpo giratorio del cabezal.

**F** Les têtes TA-TRONIC ont été conçues avec deux contrepoids pour l'équilibrage automatique. Ils se déplacent dans le sens contraire par rapport au coulisseau. Dans les TA-TRONIC, le liquide réfrigérant sort de deux buses orientables placées à côté du coulisseau, après avoir traversé le cône et le corps rotatif de la tête.

**I** Le teste TA-TRONIC sono state progettate con due contrappesi per il bilanciamento automatico, che si muovono in senso opposto alla slitta. Nelle TA-TRONIC il liquido refrigerante esce da due ugelli orientabili posti a fianco della slitta dopo aver attraversato il cono ed il corpo rotante della testa.



## K02



REF.	CODE
K02 TA-T 100 1FK7022-5AK71-1HA5	501201000400
K02 TA-T 100 FANUC bis 1/6000	501201000800
K02 TA-T 100 AKM22C-ANBNC-00	501201000600
K02 TA-T 125 1FK7022-5AK71-1HA5	501201250400
K02 TA-T 125 FANUC bis 1/6000	501201250800
K02 TA-T 125 AKM22C-ANBNC-00	501201250600
K02 TA-T 160 1FK7032-2AK71-1EA2	501201600400
K02 TA-T 160 FANUC bis 1/6000	501201600800
K02 TA-T 160 AKM22C-ANBNC-00	501201600600
K02 TA-T 200 1FK7032-2AK71-1EA2	501202000400
K02 TA-T 200 FANUC bis 1/6000	501202000800
K02 TA-T 200 AKM22C-ANBNC-00	501202000600

## K03



1 P120 1 P130

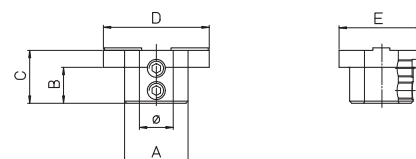
REF.	CODE
KIT K03 TA-T 100-125	501200301001
KIT K03 TA-T 160-200	501200301601

• Complete range of cones on page 17 • Komplette Konusreihe auf Seite 17 • Gama completa de los conos en la pag. 17  
 • Gamme complète des cônes à la page 17 • Gamma completa dei coni a pag. 17

## MHD'

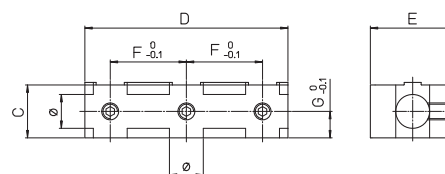


REF.	MHD'
TA-T 100-125	50
TA-T 160-200	80



## P 120

	REF.	CODE	Ø H7	A	B	C	D	E	Kg.
TA-T 100-125	P120	431550160250	16	30	17	25	50	40	0.2
TA-T 160-200		431550250380	25	47	27.5	38	76	54	0.55

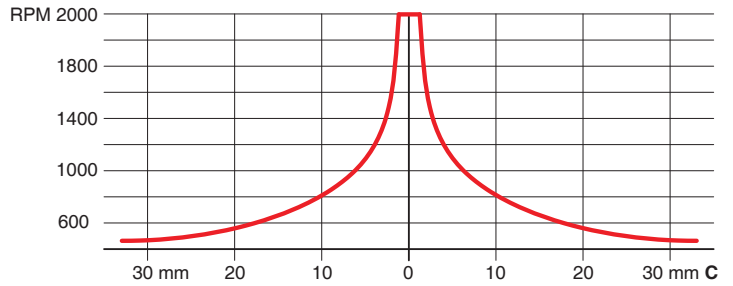
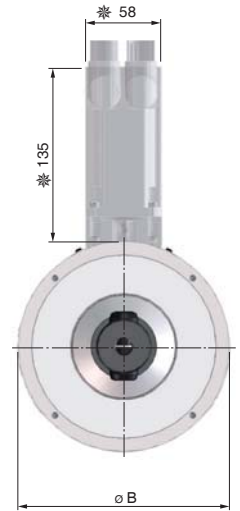
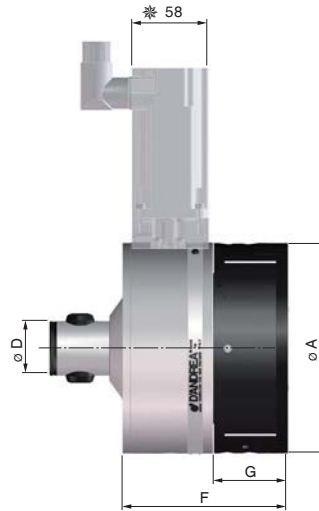
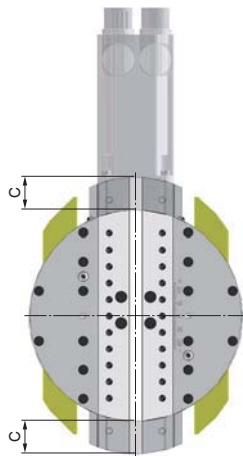


## P 130

	REF.	CODE	Ø H7	C	D	E	F	G	Kg.
TA-T 100-125	P130	433040250950	16	25	95	40	37	10.5	0.5
TA-T 160-200		433054381520	25	38	152	54	59.5	16.5	1.6



- TECHNICAL DATA
- TECHNISCHE DATEN
- DATOS TECNICOS
- DONNÉES TECHNIQUES
- DATI TECNICI



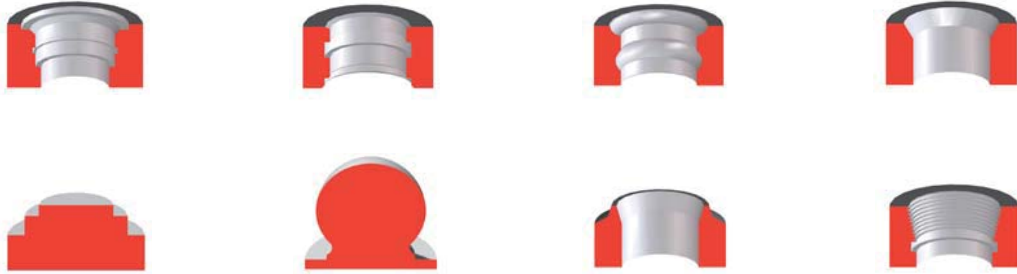
		TA-T 100	TA-T 125	TA-T 160	TA-T 200
Ø A	mm	100	125	160	200
Ø B	mm	100.5		160.5	
C	mm	± 12	± 17	± 25	± 32.5
Ø D	mm	(MHD'50) 32 <sup>-0.005</sup> <sub>-0.008</sub>		(MHD'80) 42 <sup>-0.005</sup> <sub>-0.008</sub>	
F	mm	89	93	125	
G	mm	40.5	44.5	56	
Ø L	mm	10 ~ 72	10 ~ 81	20 ~ 109	20 ~ 124
M	mm	75		125	
Ø N	mm	72 ~ 122	63 ~ 131	103 ~ 203	88 ~ 218
O	mm	100		160	
Ø P	mm	122 ~ 200	131 ~ 250	203 ~ 320	218 ~ 400
Q	mm	25.5		38.5	
Max. mm/min	mm/min	1 ÷ 500			
Max. ̸/min	RPM	2000	1800	1600	1400
• Weight without the cone and motor • Gewicht ohne Konus und motor • Peso sin cono y motor • Poids sans cône et le moteur • Peso senza cono e motore	Kg	4.2	6.3	15.5	20.5
• Radial force • Vorschubkraft • Fuerza radial • Force radiale • Forza radiale	daN	150		250	
• Torque • Drehmoment • Momento de torsión • Couple maxi • Momento torcente	Nm	400		800	
• Boring accuracy • Bohrgenauigkeit • Precisión en mandrinado • Précision d'alésage • Precisione in alesatura		H7			
• Max chip removal • Max Materialabnahme • Max. arranque de viruta • Max du copeau • Max asportazione	mm <sup>2</sup> C40	0,75	0,85	1	
• Roughness • Rauigkeit • Rugosidad • Rugosità • Rugosità	Ra	0,8 ~ 1,2			

• \*Rough measures that may vary on changing the motor. • \*Bezeichnende Masse, welche sich bei Ändern des Motors, ändern können. • \*Medidas indicativas que pueden variar cuando varía el motor. • \*Mesures indicatives qui peuvent se modifier lorsque le moteur varie. • \*Misure indicative che possono variare al variare del motore.



# D'ANDREA

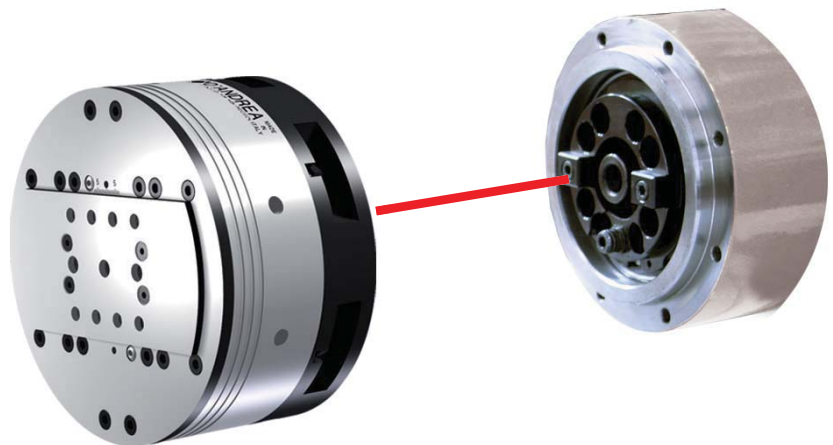
## U-COMAX



*Unit and transfer solutions*



- GENERAL FEATURES
- ALLGEMEINE MERKMALE
- CARACTERÍSTICAS GENERALES
- CARACTÉRISTIQUES GÉNÉRALES
- CARATTERISTICHE GENERALI



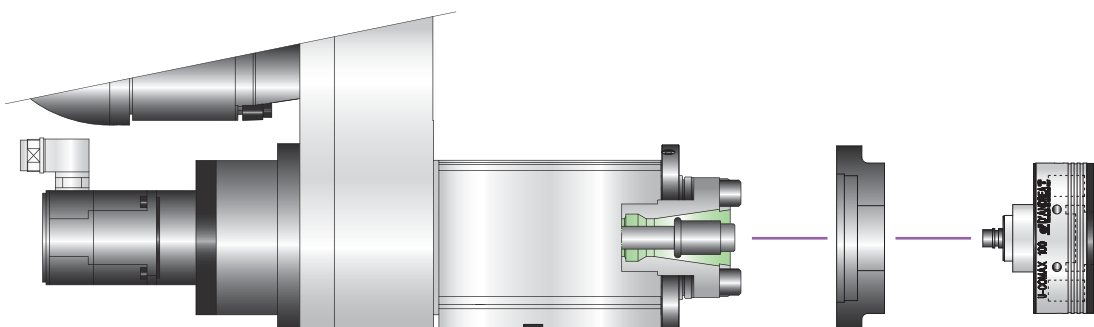
**B** U-Comax boring and facing heads are axial command heads designed to be used on transfer machines, machining units, and special machinery. Even during rotation the feed control of the toolholder slide is commanded by a U-Drive drive unit, mounted behind the spindle and managed directly by the NC of the machine tool. U-Comax heads are used for inner facing, outer facing, back-facing, inner and outer turning operations, grooves, phonographic grooves, cylindrical and conical threading, conical and variable boring, concave and convex and spherical operations, corner rounding, through interpolation with the other the machine axes.

**D** Die Bohr- und Planschleifköpfe U-Comax sind achsgesteuert und für die Anwendung auf Transfermaschinen, Bedieneinheiten und Spezialmaschinen bestimmt. Die Kontrolle des Werkzeughalterschlittenvorschubs wird auch während der Rotation von einer motorisierten U-Drive Gruppe gesteuert, welche nach der Spindel montiert ist und direkt von der CNC der Werkzeugmaschine verwaltet wird. Die U-Comax Köpfe werden zum Innen- Außen- und Unterschnittplanschleifen, Innen- und Aussendrehen, Kerben, phonographische Spiralen, zylindrisches und konisches Gewindeschneiden, konische, auch variable Bohrungen, konkave und konvexe Rundbearbeitungen mittels Interpolation mit den anderen Maschinenachsen eingesetzt.

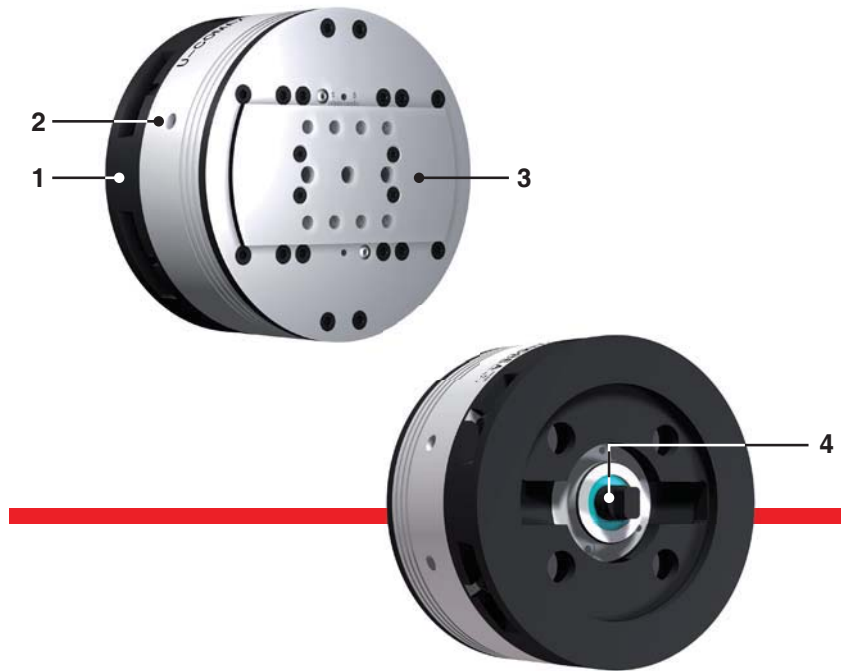
**E** Los cabezales para mandrinar y refrentar U-Comax son cabezales de accionamiento axial destinados al empleo en máquinas transfer, estaciones de trabajo y máquinas especiales. El control del avance de la corredera portaherramientas, incluso durante la rotación, está controlado por un grupo de motorización U-Drive montado detrás del husillo y gestionado directamente por el CNC de la máquina herramienta. Los cabezales U-Comax se emplean para elaboraciones de refrentado interno, externo y bajo-esquadra, torneado interno y externo, canales, espirales fonográficas, roscadas cilíndricas y cónicas, mandrinados cónicos incluso variables, radios cóncavos y convexos y operaciones esféricas, mediante interpolación con los demás ejes de la máquina.

**F** Les têtes à aléser et à dresser U-Comax sont des têtes à commande axiale, destinées à l'utilisation sur des lignes de transfert, des unités opérationnelles et des machines spéciales. Le contrôle de l'avancement du coulisseau porte-outil, même pendant la rotation, est commandé par un groupe de motorisation U-Drive, monté à l'arrière de la broche et géré directement par le contrôle numérique de la machine-outil. Les têtes U-Comax sont utilisées pour les usinages de dressage interne, externe et contre-dépouille, les tournages internes et externes, les cannelures, les spirales phonographiques, les filetages cylindriques et coniques, les alésages coniques même variables, les rayons de courbure concaves et convexes et les opérations sphériques, à l'aide de l'interpolation avec les autres axes de la machine.

**I** Le teste per alesare e sfacciare U-Comax sono teste a comando assiale destinate all'impiego su macchine transfer, unità operatrici e macchine speciali. Il controllo dell'avanzamento della slitta portautensili anche durante la rotazione è comandato da un gruppo di motorizzazione U-Drive montato posteriormente al mandrino e gestito direttamente dal CNC della macchina utensile. Le teste U-Comax sono impiegate per lavorazioni di sfacciatura interna, esterna e sottosquadra, tornitura interna ed esterna, canalini, spirali fonografiche, filettature cilindriche e coniche, alesature coniche anche variabili, raggiature concave e convesse e operazioni sferiche, mediante interpolazione con gli altri assi della macchina.



- 1
  - Adapter flange to the machine
  - Anpassungsflansch der Maschine
  - Brida de adaptación a la máquina
  - Bride d'adaptation à la machine
  - Flangia di adattamento alla macchina
- 2
  - Rotating body
  - Rotierender Körper
  - Cuerpo giratorio
  - Corps rotatif
  - Corpo rotante
- 3
  - Toolholder slide
  - Werkzeughalterschlitten
  - Corredera portaherramientas
  - Coulisseau porte-outils
  - Slitta portautensili
- 4
  - Drive shaft
  - Antriebswelle
  - Eje de transmisión
  - Arbre de transmission
  - Albero di trasmissione



**GB** The U-Drive drive unit for U-Comax heads is mounted behind the spindle of the machine. It is controlled by an axis of the numerical control and mechanically connected to the U-Comax head drive with a transmission shaft that crosses the spindle of the machine. The U-Drive drive unit can be configured in various ways depending on the required application and the design of the machine.

**D** Die U-Drive Motorisierung der U-Comax-Köpfe wird hinter der Maschinenspindel montiert, von einer Achse der numerischen Steuerung verwaltet und mechanisch an den Bewegungsanschluss der U-Comax-Köpfe durch eine Antriebswelle angeschlossen, die die Spindel der Maschine selbst durchquert. Die U-Drive Motorisierung kann je nach Anbringung und Bauform der Maschine verschiedenartig gestaltet werden.

**E** La motorización U-Drive para los cabezales U-Comax se monta en la parte trasera del husillo de la máquina. Es gestionada por un eje del control numérico y conectada mecánicamente a la toma de movimiento del U-Comax por un eje de transmisión que atraviesa el husillo de la máquina misma. La motorización U-Drive puede tener diferentes configuraciones según la aplicación y la forma constructiva de la máquina.

**F** Le système moteur U-Drive pour les têtes U-Comax est monté à l'arrière par rapport à la broche de la machine. Il est géré par un axe de la commande numérique et est relié mécaniquement à la prise de mouvement des têtes U-Comax par un arbre de transmission qui traverse la broche de la machine. Le système moteur U-Drive peut avoir différentes configurations selon l'application et la forme de construction de la machine.

**I** La motorizzazione U-Drive per le teste U-Comax viene montata posteriormente al mandrino della macchina, viene gestito da un asse del controllo numerico e collegata meccanicamente alla presa di moto della teste U-Comax con un albero di trasmissione che attraversa il mandrino della macchina stessa. La motorizzazione U-Drive può assumere diverse configurazioni a seconda dell'applicazione e della forma costruttiva della macchina.



U-COMAX

U-DRIVE



- APPLICATION
- ANBRINGUNG
- APLICACIÓN
- APPLICATION
- APPLICAZIONI

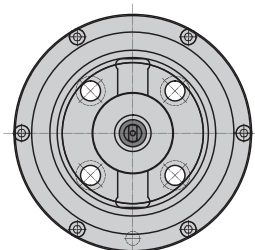
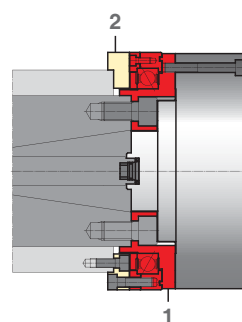
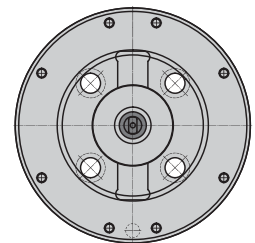
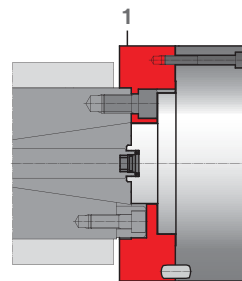
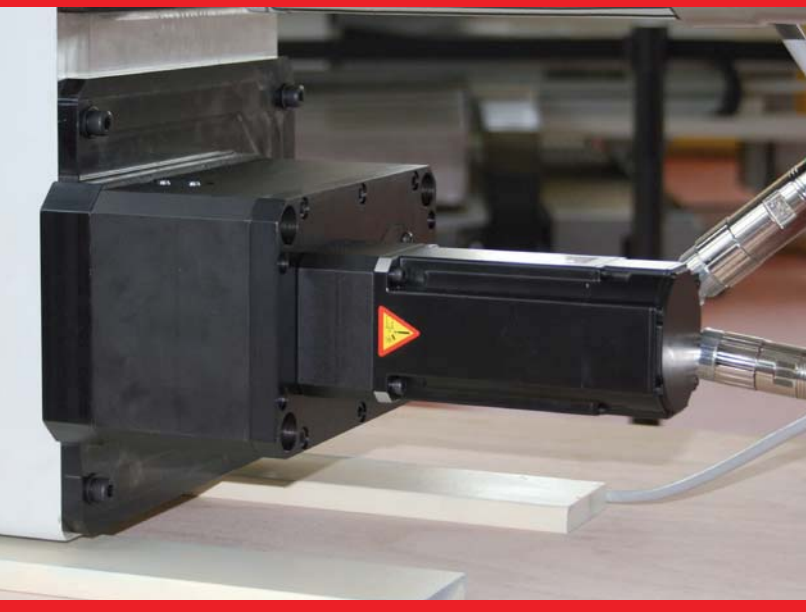
**GB** U-COMAX is installed on the machine by a flange (1) and where required with a connection (2) ring. The flange and connection ring type to use depend on the model of the machine and can be easily constructed by the Customer or provided by D'Andrea.

**D** U-COMAX werden mittels eines Flanschs (1) und wenn erforderlich mit einem Verbindungsring (2), auf die Maschine montiert. Die Art des anzuwendenden Flansches und des Verbindungsringes hängt vom Maschinenmodell ab und kann vom Kunden selbst hergestellt oder von D'Andrea geliefert werden.

**E** Los U-COMAX se montan en la máquina mediante una brida (1) y donde es necesario, con un anillo de conexión (2). El tipo de estribo y el anillo de conexión dependen del modelo de la máquina y pueden ser fácilmente construidos por el Cliente o suministrados por D'Andrea.

**F** Les U-COMAX sont montées sur la machine avec une bride (1) et, lorsque cela est nécessaire, avec une bague de liaison (2). Le type de bride et la bague de liaison à utiliser dépendent du modèle de la machine et peuvent être facilement fabriquées par le client ou fournies par D'Andrea.

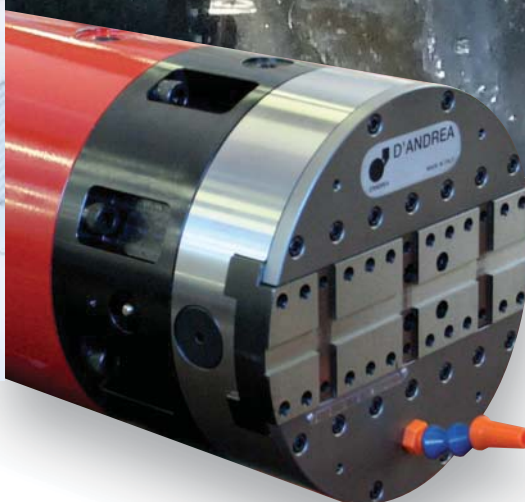
**I** Le U-COMAX vengono montate sulla macchina mediante una flangia (1) e dove necessario con un anello di collegamento (2). Il tipo di flangia e l'anello di collegamento da adottare dipendono dal modello della macchina e possono essere facilmente costruiti dal Cliente o forniti dalla D'Andrea.





# D'ANDREA U-COMAX

- BALANCING AND COOLANT SUPPLY
- AUSGLEICH UND ZUFÜHRUNG DES KÜHLMITTELS
- EQUILIBRADO Y PASO DEL LÍQUIDO REFRIGERANTE
- ÉQUILIBRAGE ET AMENÉE DE LIQUIDE RÉFRIGÉRANT
- BILANCIATURA E ADDUZIONE LIQUIDO REFRIGERANTE



**GB** U-COMAX heads are designed with two counter-weights for automatic balancing, which move opposite to the slide making it possible to machine at a higher number of rpm without noticeable oscillations.

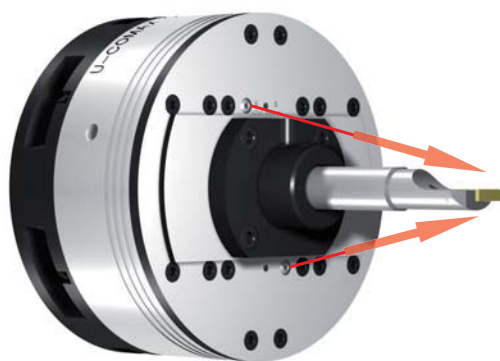
**D** Die U-COMAX-Köpfe wurden mit zwei Gegengewichten für die automatische Auswuchtung entworfen. Sie bewegen sich entgegengesetzt zum Schlitten und ermöglichen es, bei einer hohen Umdrehungszahl ohne nennenswerte Schwingungen zu arbeiten.

**E** Los cabezales U-COMAX se han diseñado con dos contrapesos para el equilibrado automático, que se mueven en el sentido opuesto al de la corredera permitiendo el trabajo a un elevado número de revoluciones sin oscilaciones apreciables.

**F** Les têtes U-COMAX ont été conçues avec deux contrepoids pour l'équilibrage automatique. Ils se déplacent dans le sens contraire par rapport au coulisseau, permettant ainsi d'usiner à un nombre élevé de tours, sans oscillations notables.

**I** Le teste U-COMAX sono state progettate con due contrappesi per il bilanciamento automatico, che si muovono in senso opposto alla slitta permettendo di lavorare ad un elevato numero di giri senza oscillazioni apprezzabili.





**GB** Internal grooves that allow coolant to pass through from the machine spindle to two adjustable nozzles located next to the slide are provided inside U-COMAX rotating body. This noteworthy advantage ensures longer duration of the insert, quicker cutting speed and the obtainment of good surface finishes. The centralized supply of coolant does not harm the U-COMAX whose inner labyrinths are protected by an o-ring. It is advisable not to exceed a pressure of 40 BAR. U-Comax heads are designed for automatic lubrication with oil sprayed on the slide guiding rails and lead screw.

**D** Innerhalb des Drehkörpers des U-COMAX sind Kanäle vorgesehen, die den Durchfluss der Kühlflüssigkeit von der Maschinenspindel bis zu den zwei verstellbaren Düsen ermöglichen, die sich seitlich vom Schlitten befinden. Dieser erhebliche Vorteil garantiert eine längere Lebensdauer des Einsatzes, eine höhere Schnittgeschwindigkeit und die Erzielung einer hohen Oberflächengüte. Die zentralisierte Zufuhr der Kühlflüssigkeit schädigt den U-COMAX nicht, denn seine internen Labyrinth sind durch Dichtungsringe geschützt. Es empfiehlt sich, mit nicht mehr als 40 BAR Druck zu arbeiten. Die U-COMAX-Köpfe wurden mit zwei Gegengewichten für die automatische Auswuchtung entworfen. Sie bewegen sich entgegengesetzt zum Schlitten und ermöglichen es, bei einer hohen Umdrehungszahl ohne nennenswerte Schwingungen zu arbeiten.

**E** En el interior del cuerpo giratorio del U-COMAX están previstas unas canalizaciones que permiten el paso del líquido refrigerante del husillo de la máquina hasta dos boquillas orientables situadas al lado de la corredera. Esta notable ventaja asegura una mayor duración de la plaqueta de corte, una mayor velocidad de corte y la obtención de buenos acabados superficiales. El suministro centralizado del líquido refrigerante no daña al U-COMAX cuyos canales internos están protegidos por retenes estancos. Se aconseja no superar los 40 BARES de presión. Los U-COMAX están predisuestos para la lubricación automática con aceite nebulizado de las guías de desplazamiento del carro y del husillo.

**F** Des canalisations sont prévues à l'intérieur du corps rotatif de l'U-COMAX qui permettent le passage du liquide d'arrosage de la broche de la machine jusqu'aux deux buses orientables placées sur les côtés du coulisseau. Cet avantage important garantit une plus longue durée de vie de la plaquette, une vitesse de coupe plus élevée et l'obtention d'excellents finissages des surfaces. L'amenée centralisée de liquide d'arrosage n'endommage pas l'U-COMAX, dont les labyrinthes internes sont protégés par des anneaux d'étanchéité. Nous conseillons de ne pas dépasser les 40 bars de pression. Les U-Comax sont prévus pour la lubrification automatique du coulisseau et de la vis mère avec de l'huile nébulisée.

**I** All'interno del corpo rotante della U-COMAX sono previste delle canalizzazioni che permettono il passaggio del liquido refrigerante dal mandrino della macchina sino a due ugelli orientabili posti a fianco della slitta. Questo notevole vantaggio assicura una maggiore durata dell'inserto, una maggiore velocità di taglio e l'ottenimento di buone finiture superficiali. L'adduzione centralizzata del liquido refrigerante non danneggia la U-COMAX i cui labirinti interni sono protetti da anelli di tenuta. È consigliabile non superare i 40 BAR di pressione. Le U-Comax sono predisposte per la lubrificazione automatica con olio nebulizzato delle guide di scorrimento della slitta e la vite madre.



# D'ANDREA

## U-COMAX

- SUPPLY
- LIEFERUMFANG
- SUMINISTRO
- FOURNITURE
- FORNITURA

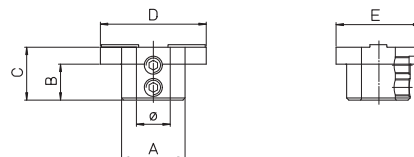


**K02**

REF.	CODE
K02 CMX 100	500510010001
K02 CMX 125	500512510001
K02 CMX 160	500516010001
K02 CMX 200	500520010001



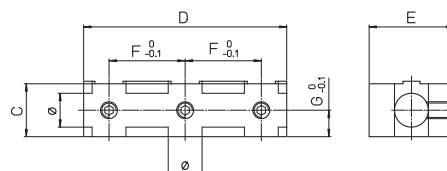
**P 120**



	REF.	CODE	ØH7	A	B	C	D	E	Kg.
CMX 100	P120	431550160260	16	30	17	25	40	37.5	0.15
CMX 125		431550160261			16				
CMX 160		431550250390	25	47	36	38	61	58	0.55
CMX 200		431550250391							



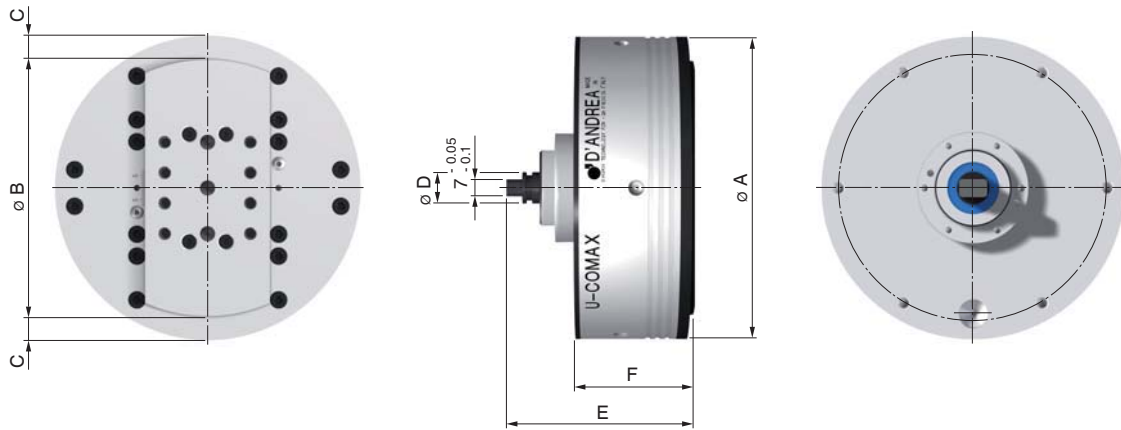
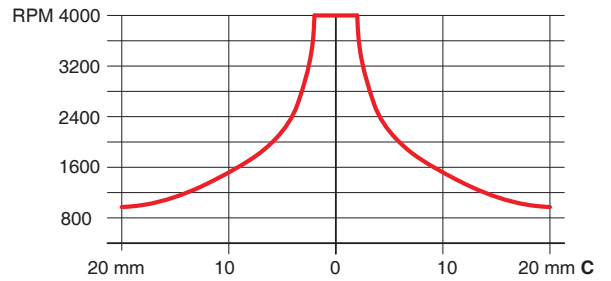
**P 130**



	REF.	CODE	ØH7	C	Ø D	E	F	G	Kg.
CMX 100	P130	433037250650	16	25	65	37.5	22	10.5	0.25
CMX 125		433046250810			81	46	30		0.45
CMX 160		433058381030	25	38	103	58	35	16.5	0.9
CMX 200		433072381330			133	72	50		1.7



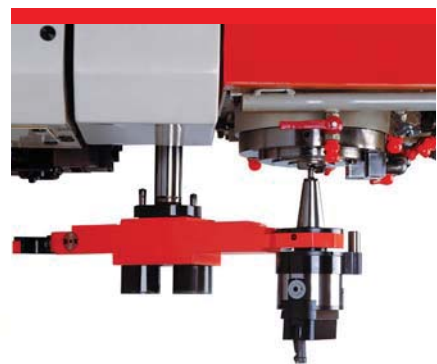
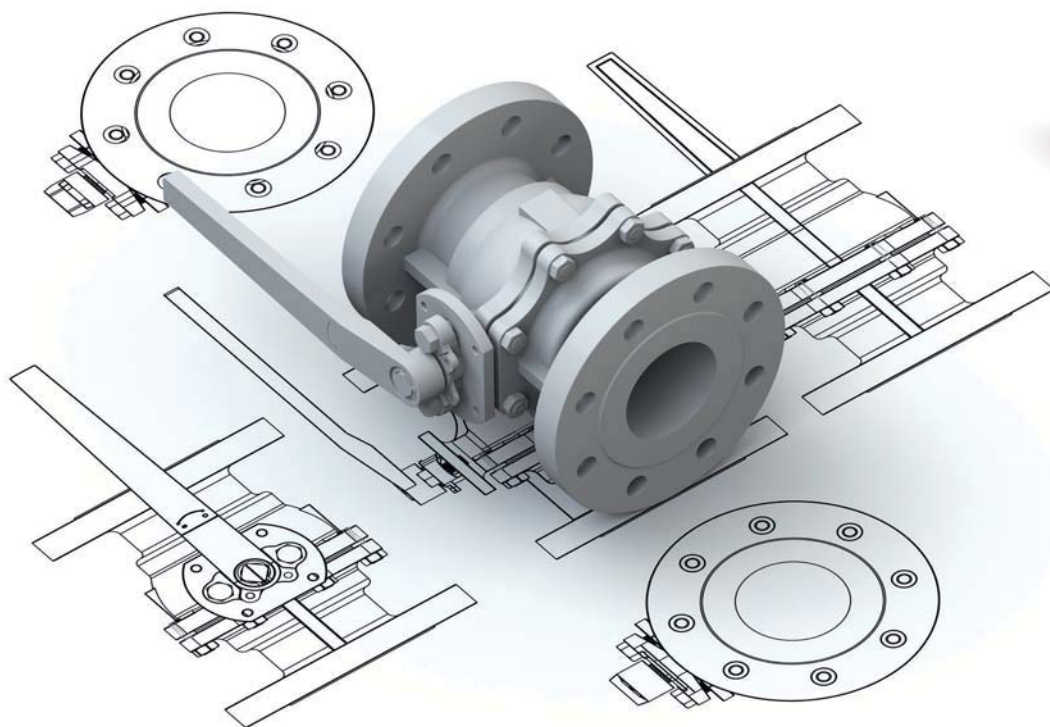
- TECHNICAL DATA
- TECHNISCHE DATEN
- DATOS TECNICOS
- DONNÉES TECHNIQUES
- DATI TECNICI



		CMX 100	CMX 125	CMX 160	CMX 200
Ø A	mm	100.5	125	160	200
Ø B	mm	83	105	128	167
C	mm	± 9	± 12	± 16	± 20
Ø D	mm	13 <sup>-0.01</sup> <sub>-0.02</sub>		15 <sup>-0.01</sup> <sub>-0.02</sub>	
E	mm	86.5		109.5	
F	mm	52.5		69	68
Ø G	mm	10 ~ 62	10 ~ 72	20 ~ 81	20 ~ 109
H	mm	60	75	100	125
Ø I	mm	62 ~ 102	72 ~ 122	81 ~ 131	103 ~ 203
L	mm	80	100	125	160
Ø M	mm	122 ~ 160	122 ~ 200	131 ~ 250	203 ~ 320
N	mm	25.5		38.5	
Max. mm/min	mm/min	1 ÷ 500			
Max. ̸/min	RPM	4000	3600	3200	2800
• Weight • Gewicht • Peso • Poids • Peso	Kg	2.4	3.2	9.8	11.5
• Radial force • Vorschubkraft • Fuerza radial • Force radiale • Forza radiale	daN	150		250	
• Torque • Drehmoment • Momento de torsión • Couple maxi • Momento torcente	Nm	400		800	

# D'ANDREA AUTORADIAL

- GENERAL FEATURES
- ALLGEMEINE MERKMALE
- CARACTERÍSTICAS GENERALES
- CARACTÉRISTIQUES GÉNÉRALES
- CARATTERISTICHE GENERALI



**GB** Facing heads with automatic feed and quick return of the slide without stopping or reversing the spindle of the machine tool. Available in 4 models: AR 100, AR 125, AR 160 and AR 200; they have got a feed and quick return. To change the feed, some interchangeable, optional, gear blocks are available, for feeds in mm/rev. of: 0.05; 0.10; 0.20; 0.30; 0.40; 0.50; 0.60 and a quick return of 0.08 mm/rev. The interchangeable arbor uses the same locking system used in the MHD' modular system. A simple attachment of the toolholders to the slide favours the manufacturing of special toolholders.

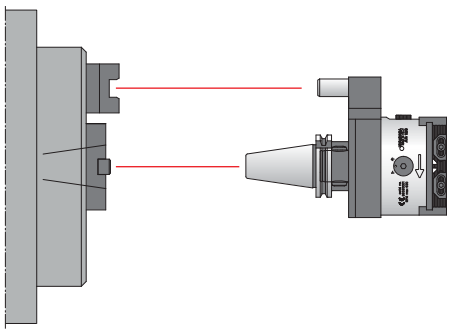
**D** Plandrehköpfe mit automatischem Vorschub und Eilrücklauf für den Schlitten, ohne dass die Spindel der Werkzeugmaschine gestoppt oder die Drehrichtung geändert werden muß. Hergestellt in vier Modellgrößen AR 100, AR 125, AR160 und AR 200; selbstverständlich mit automatischem Vorschub und Eilrücklauf. Verschiedene, wählbare Vorschübe stehen optional durch auswechselbare Getriebeblöcke in mm/U von 0,05; 0,10; 0,20; 0,30; 0,40; 0,50; 0,60 und einem Eilrücklauf von 0,80 mm/U zur Verfügung. Der auswechselbare Kegel hat das gleiche Spannsystem wie es in dem MHD'-Modularsystem bereits verwendet wird. Eine einfache Klemmung der Werkzeughalter am Schlitten erlaubt den Einsatz von Spezialwerkzeughaltern.

**E** Cabezales de refrentado con avance automático de trabajo y retorno rápido del carro sin la parada o la inversión del husillo de la máquina herramienta. Construidos en 4 modelos: AR 100, AR 125, AR160 y AR 200; tienen avance y retorno rápido. Para variar los avances están previstos bloques de engranajes intercambiables, opcionales, para avances en mm/vuelta de 0,05; 0,10; 0,20; 0,30; 0,40; 0,50; 0,60 y un retorno rápido de 0,80 mm/vuelta. El cono intercambiable adopta el mismo acoplamiento del sistema modular MHD'. Un simple acoplamiento de los portaherramientas al carro favorece la construcción de portaherramientas especiales.

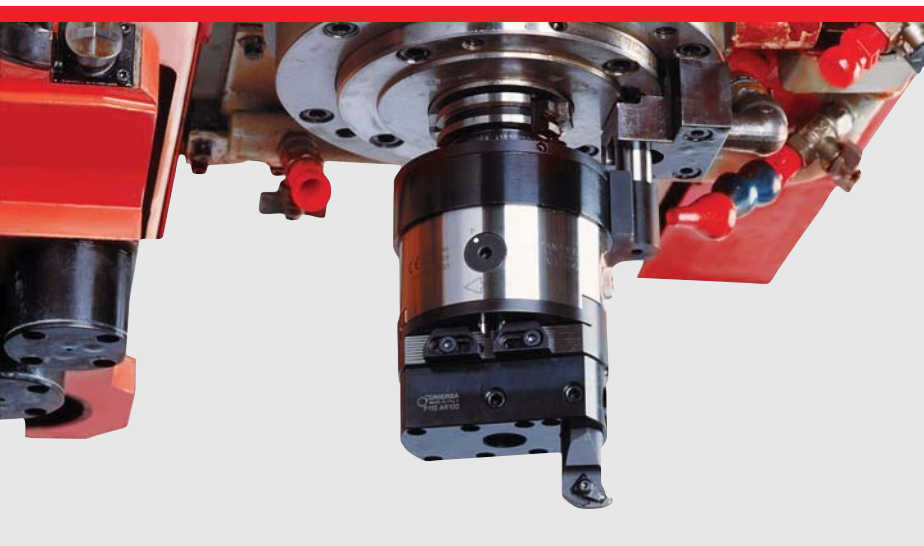
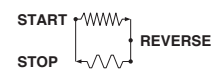
**F** Têtes à surfacer avec avance automatique et retour rapide du coulisseau, sans obligation d'arrêter ou d'inverser la rotation de la broche. Ces têtes sont fabriquées en 4 modèles: AR 100, AR 125, AR 160 et AR 200. Elles sont munies d'un système d'avance et de retour rapide. Pour changer les avances, des systèmes interchangeables et optionnels sont disponibles pour les avances suivantes: 0,05; 0,10; 0,20; 0,30; 0,40; 0,50; 0,60 et un retour rapide du coulisseau de 0,80 mm/tour. Les cônes sont interchangeables et leur mode de fixation est identique à celui du système modulaire MHD'. La fixation très simplifiée des porte-outils au coulisseau favorise l'emploi et la fabrication de porte-outils spéciaux.

**I** Teste di sfacciatura con avanzamento automatico di lavoro e ritorno rapido della slitta senza l'arresto o l'inversione del mandrino della macchina utensile. Costruite in 4 modelli: AR 100, AR 125, AR 160 e AR 200; hanno un avanzamento ed il ritorno rapido. Per variare gli avanzamenti sono previsti dei blocchetti di ingranaggi intercambiabili, opzionali, per avanzamenti in mm/giro di: 0,05; 0,10; 0,20; 0,30; 0,40; 0,50; 0,60 ed un ritorno rapido di 0,80 mm/giro. Il cono intercambiabile adotta lo stesso fissaggio del sistema modulare MHD'. Un semplice attacco dei portautensili alla slitta favorisce la costruzione di portautensili speciali.





## For automatic facing



**GB** The AUTORADIAL heads are applicable on machining centres and on N.C. machines and, without the need of any electronic interface, they can execute automatically a working cycle of: facing, backfacing, internal or external grooving for spring washers and O-rings, record spiral cutting on flanges. The cycle is composed of the working feed and of the quick return of the slide without ever stopping or reversing the rotation of the spindle. To reset the cycle, merely reverse the spindle rotation for a few revolutions.

**D** Die Autoradial Köpfe können an Bearbeitungszentren und an NC-Maschinen verwendet werden, ohne dass elektronische Schnittstellen benötigt werden. Sie können folgende Bearbeitungen automatisch ausführen: plandrehen, hinterdrehen, innen-oder Außennuten einstechen, für Federringe oder O-Ringe, spiralnutenschneiden am Flansch. Der Arbeitsablauf Vorschub und Eilrücklauf des Schlittens ist ohne jedes Stoppen oder einer Drehrichtungsänderung der Spindel möglich. Um den Zyklus zu wiederholen, genügt es, die Spindeldrehrichtung für wenige Umdrehungen zu ändern.

**E** Los AUTORADIAL son aplicables en centros de mecanizado y en máquinas de CN, sin necesidad de ninguna interfase electrónica, y efectúan automáticamente un ciclo de trabajo de: refrentado, refrentado bajo escuadra, alojamiento interior y exterior para anillos elásticos o retenes, espirales fonográficas en pletina. El ciclo está compuesto por el avance de trabajo y retorno rápido del carro sin parar o invertir la rotación del husillo. El restablecimiento del ciclo se efectúa con la simple inversión del sentido de rotación del husillo durante unas vueltas.

**F** Les têtes AUTORADIAL sont utilisées sur des centres d'usinage ou des machines à CN sans aucune interface électronique. Elles peuvent exécuter en cycle de travail automatique les opérations suivantes: surfacage, tournage, rainurage intérieur et extérieur pour rondelles élastiques et joints toriques, taillage de spirales sur des brides. Un cycle de travail est composé de l'avance de travail et du retour rapide du coulisseau et il s'accomplit sans devoir arrêter ou inverser la rotation de la broche. Pour revenir au cycle initial, il suffit simplement d'inverser la rotation de la broche pendant quelques tours.

**I** Le AUTORADIAL sono applicabili sui centri di lavoro e sulle macchine a CN e senza bisogno di alcuna interfaccia elettronica od asservimento. Eseguono automaticamente un ciclo di lavoro di: sfacciatura, sfacciatura in sottosquadra, sede interna od esterna per anelli elastici od O-ring, spirale fonografica su flangia. Il ciclo è composto dall'avanzamento di lavoro e ritorno rapido della slitta senza mai arrestare o invertire la rotazione del mandrino. Il ripristino del ciclo si esegue con la semplice inversione del senso di rotazione del mandrino per qualche giro.

# D'ANDREA AUTORADIAL

- COMPONENTS
- KOMPONENTEN
- COMPONENTES
- COMPOSANTS
- COMPONENTI

- 1**
- Override (A), return (R)
  - Vorschubschalter (A), Eilrücklauf (R)
  - Selección del avance (A), retorno (R)
  - Sélecteur d'avance (A), retour (R)
  - Selettore avanzamento (A), ritorno (R)

- 2**
- Limit blocks
  - Endanschlag
  - Tope de fin de carrera
  - Goujons de fin de course
  - Tasselli di finecorsa

- 3**
- Control screw
  - Kontrollschraube
  - Tornillo de mando
  - Vis de commande
  - Vite comando

- 4**
- Check pin
  - Anschlag
  - Perno de bloqueo
  - Piton de retenue
  - Perno di ritegno

- 5**
- Interchangeable feed block
  - Auswechselbares Vorschubgetriebe
  - Bloque avances intercambiables
  - Bloc d'avances interchangeables
  - Blocchetto avanzamenti intercambiabili

- 6**
- Tool slide
  - Werkzeugschlitten
  - Guía portaherramientas
  - Coulisseau
  - Slitta portautensili

- 7**
- Interchangeable arbor
  - Auswechselbarer Kegel
  - Cono intercambiable
  - Cône interchangeable
  - Cono intercambiabile

- 8**
- Drive flange
  - Mitnehmerflansch
  - Brida de arrastre
  - Bride d'entraînement
  - Flangia di trascinamento

- 9**
- Rotating body
  - Rotierender Körper
  - Cuerpo giratorio
  - Corps rotatif
  - Corpo rotante



- INSTRUCTIONS TO REPLACE THE FEED BLOCK
- ANWEISUNGEN FÜR DEN AUSTAUSCH DES VORSCHUBMODULS
- INSTRUCCIONES PARA SUSTITUIR EL BLOQUE AVANCES
- INSTRUCTIONS POUR SUBSTITUER LE BLOC D'AVANCES
- ISTRUZIONI PER SOSTITUIRE IL BLOCCHETTO AVANZAMENTI

- a**
- Loosen the screw 1
  - Schrauben 1 lockern
  - Aflojar los tornillos 1
  - Desserer vis 1
  - Allentare viti 1

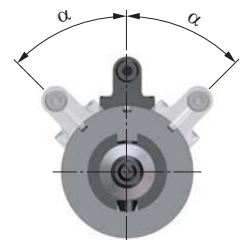
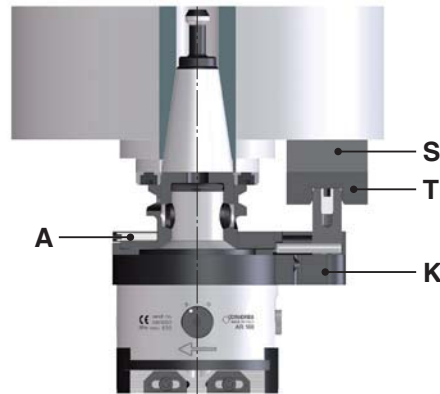
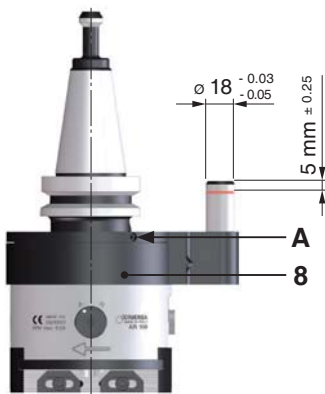
- b**
- Extract block 5
  - das Modul 5 herausziehen
  - Quitar el bloque 5
  - Extraire bloc 5
  - Estrarre blocchetto 5

- c**
- Insert new block 5 lubricated with ISO-UNI XM2 grease
  - das neue, mit ISO-UNI-Fett vom Typ XM2 geschmierte Modul 5 einsetzen
  - Colocar el nuevo bloque 5 lubricado con grasa ISO-UNI tipo XM2
  - Insérer nouveau bloc 5 lubrifié avec gras ISO-UNI type XM2
  - Inserire nuovo blocchetto 5 lubrificato con grasso ISO-UNI tipo XM2

- d**
- Lock screw 1
  - Schrauben 1 festziehen
  - Fijar los tornillos 1
  - Bloquer vis 1
  - Bloccare viti 1







- ASSEMBLY
- MONTAGE
- MONTAJE
- ASSEMBLAGE
- MONTAGGIO

**GB** In the AUTORADIAL the slide is moved forward by holding back the drive flange (8) while the spindle is rotating. The T-block supplied with the K-NC KIT (K) is to be applied to a fixed part around the spindle, observing the measurements indicated. If the stroke of the check pin is not  $5 \text{ mm} \pm 0,25$ , you must adjust the position of the T-block using the spacer S. The angle  $\alpha$  is freely adjustable by loosening the 3 screws (A), turning the flange (8) to the desired angle and tightening the screws (A).

**D** Bei AUTORADIAL kommt es während der Spindelrotation durch Zurückhalten des Mitnehmerflansches (8) zur Vorschubbewegung des Schlittens. Die in dem Set K-NC (K) gelieferte Anschlagaufnahme T wird unter Berücksichtigung der angegebenen Maße an einem festen Teil um die Spindel herum angebracht. Sollte sich die Strecke des Rückhaltezapfens nicht im Bereich von  $5 \text{ mm} \pm 0,25$  befinden, ist die Position der Anschlagaufnahme T mit einer Unterlegscheibe S einzustellen. Die Wahl des Winkels  $\alpha$  ist frei und erfolgt durch das Lockern der 3 Schrauben (A), Drehen des Flansches (8) bis zum gewünschten Winkel und Festziehen der Schrauben (A).

**E** En los AUTORADIAL el movimiento de avance del carro se obtiene bloqueando la brida de arrastre (8) durante la rotación del husillo. El tope T suministrado con el KIT K-NC (K) va aplicado en una parte fija alrededor del husillo respetando las cotas indicadas. En el caso de que la carrera del tornillo de bloqueo no sea de  $5 \text{ mm} \pm 0,25$ , será necesario regular la posición del tope T a través del espesor S. La regulación del ángulo  $\alpha$  es libre y se obtiene aflojando los 3 tornillos (A), girando la brida (8) hasta el ángulo deseado y bloqueando de nuevo los tornillos (A).

**F** Dans les AUTORADIAL, le mouvement d'avance du coulisseau est obtenu en retenant la brida d'entraînement (8) pendant la rotation du mandrin. Le goujon T qui est fourni avec le KIT K-NC (K) doit être appliqué sur une partie fixe autour de la broche en respectant les mesures indiquées. Si la course du piton de retenue n'est pas de  $5 \text{ mm} \pm 0,25$ , il est nécessaire de régler la position du goujon T à l'aide de la cale S. Le réglage de l'angle  $\alpha$  est libre et on l'obtient en desserrant les 3 vis (A), en tournant la brida (8) jusqu'à l'angle désiré et en rebloquant les vis (A).

**I** Nelle AUTORADIAL il movimento di avanzamento della slitta è ottenuto trattenendo la flangia di trascinamento (8) durante la rotazione del mandrino. Il tassello T fornito con il KIT K-NC (K) va applicato ad una parte fissa attorno al mandrino rispettando le quote indicate. Nel caso che la corsa del perno di ritegno non sia di  $5 \text{ mm} \pm 0,25$ , occorrerà regolare la posizione del tassello T per mezzo dello spessore S. La regolazione dell'angolo  $\alpha$  è libera e la si ottiene allentando le 3 viti (A), ruotando la flangia (8) fino all'angolo desiderato e ribloccando le viti (A).

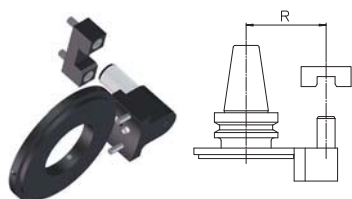


## K02



REF.	F mm/∅	CODE			
		K02 AR 100	K02 AR 125	K02 AR 160	K02 AR 200
K02 AR... - F. 0.05	0.05	500610020050	500612520050	500616020050	500620020050
K02 AR... - F. 0.1	0.1	500610020100	500612520100	500616020100	500620020100
K02 AR... - F. 0.2	0.2	500610020200	500612520200	500616020200	500620020200
K02 AR... - F. 0.3	0.3	500610020300	500612520300	500616020300	500620020300
K02 AR... - F. 0.4	0.4	500610020400	500612520400	500616020400	500620020400
K02 AR... - F. 0.5	0.5	500610020500	500612520500	500616020500	500620020500
K02 AR... - F. 0.6	0.6	500610020600	500612520600	500616020600	500620020600

## K-NC



REF.	CODE		
	R.65	R.80	R.110
K-NC R... - AR 100	394110006502	394110008002	-
K-NC R... - AR 125	-	394112508002	394112511002
K-NC R... - AR 160		394116008002	394116011003
K-NC R... - AR 200			

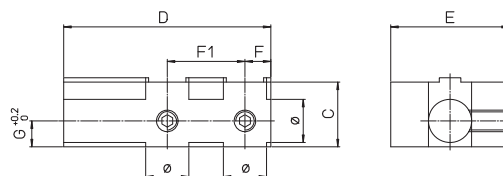
• Complete range of cones on page 17 • Komplette Konusreihe auf Seite 17 • Gama completa de los conos en la pág. 17  
 • Gamme complète des cônes à la page 17 • Gamma completa dei coni a pag. 17

## MHD'



REF.	MHD'
AR 100	50
AR 125	63
AR 160	80
AR 200	

## P 110



REF.	CODE	∅H7	C	D	E	F	F1	G	Kg.
AR 100 - P 110	433050300960	20	30	96	50	12	36	12	0.7
AR 125 - P 110	433056381200	25	39	121	56	15	45.5	16	1.3
AR 160 - P 110	433063481600	32	49	164	63	19	63	21	2.5
AR 200 - P 110									

• Interchangeable feeds • Auswechselbare Vorschübe • Avances intercambiables  
 • Avances interchangeables • Avanzamenti intercambiabili

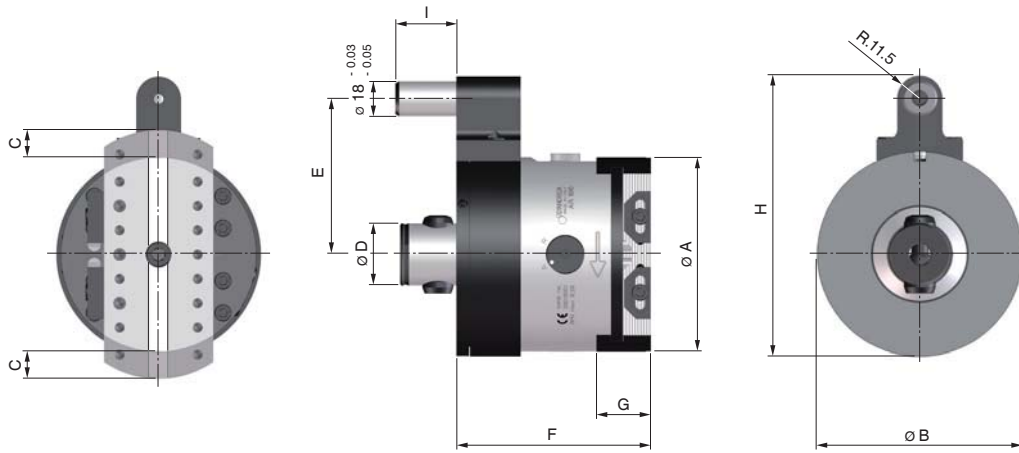
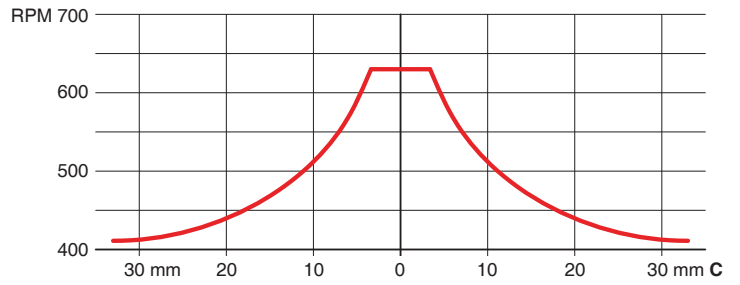
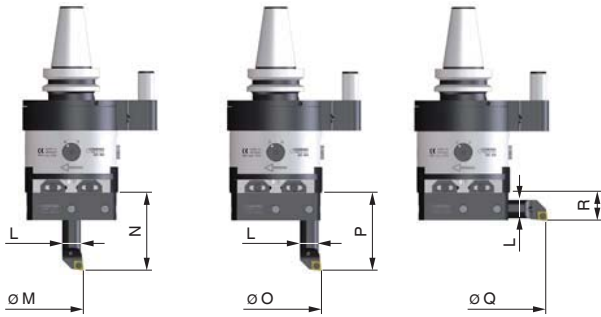
## F...



REF.	F mm/∅	CODE			
		K02 AR 100	K02 AR 125	K02 AR 160	K02 AR 200
F. 0.05 - AR...	0.05	382006005001	382006105001	382006205001	
F. 0.1 - AR...	0.1	382006010001	382006110001	382006210001	
F. 0.2 - AR...	0.2	382006020001	382006120001	382006220001	
F. 0.3 - AR...	0.3	382006030001	382006130001	382006230001	
F. 0.4 - AR...	0.4	382006040001	382006140001	382006240001	
F. 0.5 - AR...	0.5	382006050001	382006150001	382006250001	
F. 0.6 - AR...	0.6	382006060001	382006160001	382006260001	



- TECHNICAL DATA
- TECHNISCHE DATEN
- DATOS TECNICOS
- DONNÉES TECHNIQUES
- DATI TECNICI



		AR 100	AR 125	AR 160	AR 200
Ø A	mm	100	125	160	200
Ø B	mm	105	130		
C	mm	± 12.5	± 20	± 35	± 55
Ø D	mm	(MHD'50) 32 <sup>-0.005</sup> <sub>-0.008</sub>	(MHD'63) 42 <sup>-0.005</sup> <sub>-0.008</sub>	(MHD'80) 42 <sup>-0.005</sup> <sub>-0.008</sub>	
E	mm	65/80	80/110		
F	mm	100	110	125	
G	mm	28		35	
H	mm	128.5 / 143.5	156.5 / 186.5	171.5 / 201.5	191.5 / 221.5
I	mm	31.5	39.5	45.5	
L	mm	20	25	32	
Ø M	mm	76	99	144	244
N	mm	125	160	200	
Ø O	mm	148	190	270	370
P	mm	125	160	200	
Ø Q	mm	250	320	400	500
R	mm	31	40	50	
Max. $\cup$ /min	RPM	630	500	400	
• Interchangeable feeds • Auswechselbare Vorschübe • Avances intercambiables • Avances interchangeable • Avanzamenti intercambiabili	mm/ $\cup$	p. 300			
• Weight without the cone • Gewicht ohne Konus • Peso sin cono • Poids sans cône • Peso senza cono	Kg	5.5	9	14	16
• Quick return • Eilrückzug • Retorno rápido • Retour rapide • Ritorno rapido	mm/ $\cup$	0.8			

**D'ANDREA**  
Lainate - Milano

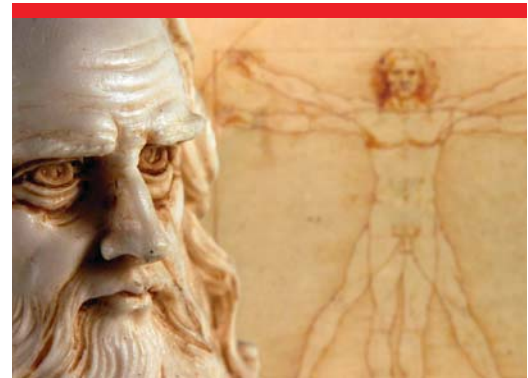
**D'ANDREA Molise**  
Castel del Giudice - Isernia

*Made in Italy*  




You will be welcome in Italy  
Wir warten auf euch in Italien  
Os esperamos en Italia  
Nous vous attendons en Italie  
Vi aspettiamo in Italia

*Ennio D'Andrea*





09/2017  
Cod. 181041001000

© **D'ANDREA s.p.a.**

Via Garbagnate 71 • 20020 Lainate (MI) Italy  
Tel. +39 02 937532.1 • Fax +39 02 93753240  
www.dandrea.com • info@dandrea.com

**Produced by**

Technical Graphic Department  
D'ANDREA s.p.a. - Lainate (MI)

- The technical data shown in this catalogue are not binding and they can be modified also without notice.
- Die angegebenen technischen Daten dieses Katalogs sind unverbindlich und dürfen auch ohne Vorankündigung geändert werden.
- Las características técnicas indicadas en el presente catálogo no son vinculantes y pueden ser modificadas también sin previo aviso.
- Les données techniques indiquées dans ce catalogue ne sont pas contraignantes et elles peuvent être modifiées même sans préavis.
- Le caratteristiche tecniche indicate in questo catalogo non sono impegnative e possono essere modificate anche senza preavviso.



**D'ANDREA SpA**

Via Garbagnate, 71 - 20020 Lainate (MI) Italy  
t. +39 02.937532.1 f. +39 02.93753240  
info@dandrea.com - www.dandrea.com



cod. 181041001000

09/17