

**THREADING
TECHNOLOGY**

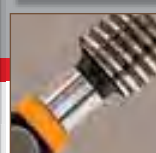
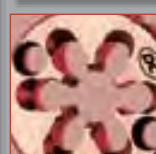
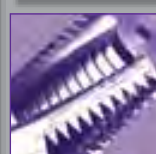
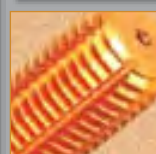
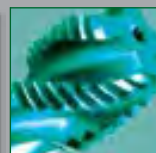

www.dcswiss.com

RU-PL-ID-2008

Основной каталог 2008

Katalog główny 2008

Наличие инструмента на складе

- ID** Идентификационный номер, в наличии на складе
- * ID** Идентификационный номер, поставляется пока есть на складе

Dostępność artykułów

- ID** Numer identyfikacyjny, dostępny z magazynu DC
- * ID** Numer identyfikacyjny, dostępny z magazynu, do wyczerpania zapasów

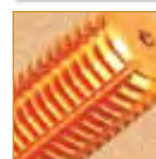

Основной каталог
Katalog główny

Мы сделали все возможное для того чтобы содержащаяся информация (чертежи, рисунки, технические данные) были верными. Однако мы не несем ответственности за допущенные ошибки и опечатки. Воспроизведение чертежей и других документов, а также их передача третьим сторонам запрещены.

Dołożyliśmy wszelkich starań aby zapewnić, że podane informacje (rysunki, wydruki, dane techniczne) są prawidłowe. Jednakże nie bierzemy odpowiedzialności za jakiegokolwiek błędy, pominięcia lub potencjalne zmiany. Kopiowanie rysunków oraz innych dokumentów i przekazywanie ich osobom trzecim jest zabronione.



THREADING TECHNOLOGY

www.dcswiss.com

NEW



N320V-3/-4 M2 – M6 6H LH
N420V-4 M8 – M20 6H LH

26 27



N360V-3 M3 – M10 6H LH
N460V-3 M12 – M20 6H LH

36 37



N520TN-4 M3 – M6 6H
N620TN-4 M8 – M16 6H

42 43

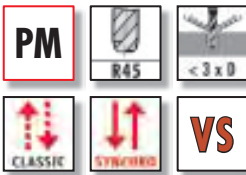

Z370VS-3 M3 – M10 6HX
Z470VS-3 M12 – M24 6HX

50 51



GG353TC-3 M5 – M10 6HX
GG453TC-3 M12 – M16 6HX

60 61



RTS362VS-3 M3 – M10 6GX

64



RTS365VS-5 M5 – M10 6HX

64



N462V-3 G1/8 – G3/4

152

КОДИРОВКА – KODYFIKACJA

DC Метчики

DC Gwintowniki

Пример - Przykład



Нормальные материалы	Materiały normalne	N								
Мягкие материалы	Materiały miękkie	W								
Вязкие материалы	Materiały trudnoobrabialne	Z								
Материалы с высоким пределом прочности	Materiały utwardzone	H								
Специальные сплавы	Stopy specjalne	S								
Специальные сплавы (Аэро)	Stopy specjalne - przemysł lotniczy	SA								
Титановые сплавы (Аэро)	Stopy tytanu - przemysł lotniczy	TL								
Чугун и алюминиевое литье	Żeliwo i aluminium	GG								
Скоростное нарезание резьбы	Gwintowanie na sztywno	RTS								
Специальное исполнение	Specjalne wykonanie		3							
Короткий утонченный хвостовик по DIN	Norma DIN, wersja krótka, chwyt przelotowy					2				
Длинный усиленный хвостовик по DIN	Norma DIN, wersja długa, chwyt wzmocniony					3				
Длинный утонченный хвостовик по DIN	Norma DIN, wersja długa, chwyt przelotowy					4				
Сверхдлинный усиленный хвостовик по DIN	Norma DIN, wersja bardzo długa, chwyt wzmocniony					5				
Сверхдлинный утонченный хвостовик по DIN	Norma DIN, wersja bardzo długa, chwyt przelotowy					6				
Короткий усиленный хвостовик по ISO	Norma ISO, wersja krótka, chwyt wzmocniony					11				
Короткий утонченный хвостовик по ISO	Norma ISO, wersja krótka, chwyt przelotowy					12				
Длинный усиленный хвостовик по ISO	Norma ISO, wersja długa, chwyt wzmocniony					13				
Длинный утонченный хвостовик по ISO	Norma ISO, wersja długa, chwyt przelotowy					14				
Прямые канавки	Proste rowki wiórowe						1			
Прямые канавки с подточкой центра	Proste rowki wiórowe, skośna powierzchnia natarcia						2			
Подточка центра	Skośna powierzchnia natarcia						3			
Левые спиральные канавки <27°	< 27° rowki wiórowe lewoskrętne						4			
Правые спиральные канавки <27°	< 27° rowki wiórowe prawoskrętne						5			
Правые спиральные канавки >27°	> 27° rowki wiórowe prawoskrętne						6			
Правые спиральные канавки >40°	> 40° rowki wiórowe prawoskrętne						7			
10° правые спиральные канавки, подточка центра	10° rowki wiórowe prawoskrętne, skośna powierzchnia natarcia						9			
Стандартный	Standard							0		
Шахматный метчик	Nakrój przerywany							1		
С увеличенным стружечным пространством	Nakrój obniżony							2		
Внутренний подвод охлаждающей жидкости	Chłodzenie wewnętrzne							3		
Шахматный метчик с внутренним подводом СОЖ	Nakrój przerywany, chłodzenie wewnętrzne							4		
С ув. стружечным пространством и подводом сож	Nakrój obniżony, chłodzenie wewnętrzne							5		
Обработка поверхности „V”	Waporyzacja „V”								V	
Износостойкое покрытие	Powłoka zabezpieczająca przed zużyciem								VS	
Покрытие нитридом титана (TiN)	Powłoka „TiN”								TN	
Покрытие карбонитридом титана (TiCN)	Powłoka „TiCN”								TC	
Азотированные	Azotowane								NI	
Предварительный метчик	Gwintownik nr 1 - wstępny									-1
Второй метчик	Gwintownik nr 2 - zgrubny									-2
Чистовой метчик (заходная часть 2-3 нитки)	Gwintownik nr 3 - wykańczający (2-3 zwoi wprowadzających)									-3
Заходная часть 3.5-5 ниток, подточка центра	3.5-5 zwoi wprowadzających, skośna powierzchnia natarcia									-4
Заходная часть 1.5-2 нитки	1.5-2 zwoi wprowadzających									-5
Заходная часть 6-8 ниток	6-8 zwoi wprowadzających									-8
Комплектные метчики	Zestaw gwintowników									-S

КОДИРОВКА – KODYFIKACJA

DC Раскатники

DC Wygniataki

Пример - Przykład



Форма стандартного полигона \varnothing 3мм	Geometria standardowa \varnothing 3 mm	FS							
Форма пассивного полигона >math>\varnothing</math> 3мм	Geometria pasywna >math>\varnothing</math> 3 mm	FP							
Форма активного полигона >math>\varnothing</math> 3мм	Geometria aktywna >math>\varnothing</math> 3 mm	FA							
Специальное исполнение	Wykonanie specjalne			3					
Усиленный хвостовик по DIN	Chwyt wzmocniony wg DIN				3				
Утонченный хвостовик по DIN	Chwyt przelotowy wg DIN				4				
Раскатник	Wygniatak					8			
Без канавок для подвода СОЖ	Bez rowków smarnych						0		
С канавками для подвода СОЖ	Z rowkami smarnymi						1		
Внутренний подвод СОЖ с радиальным выходом	Chłodzenie wewnętrzne z ujściem promieniowym						4		
Износостойкое покрытие	Powłoka zabezpieczająca przed zużyciem							VS	
Покрытие нитридом хрома (CrN)	Powłoka „CrN”							CN	
Заходная часть 2-3 нитки	2 - 3 zwoi wprowadzających								-3
Заходная часть 1,5-2 нитки	1.5 - 2 zwoi wprowadzających								-5

DC Твердосплавные резьбовые фрезы

DC Pełnowęglkowe frezy do gwintów

Пример - Przykład



Стандартное исполнение	Wykonanie standardowe	GF							
Для закаленных сталей (55 - 63 HRC)	Do stali utwardzonych (55 - 63 HRC)	GFH							
С фаской 45° для зенкования	Z fazą 45° do pogłębiania	GFS							
Для резьбовых фрез для разных диаметров резьбы	Frezy uniwersalne dla różnych średnic gwintów	GFM							
Фрезы-сверла	Wiertło-frezy	BGF							
Спиральные канавки 27° (GF), 10° (GHF)	Rowki wiórowe skrętne 27° (GF), 10° (GHF)				61				
Спиральные канавки 27° (GFS)	Rowki wiórowe skrętne 27° (GFS)				66				
Спиральные канавки 15° (GFM)	Rowki wiórowe skrętne 15° (GFM)				62				
Фрезы-сверла 2 кромки	Wiertło-frezy, 2 ostrza				67				
Фрезы-сверла 3 кромки	Wiertło-frezy, 3 ostrza				68				
Внешний подвод СОЖ	Chłodzenie zewnętrzne						1		
Внутренний подвод СОЖ	Chłodzenie wewnętrzne						6		
Длина резьбы 1.5 x D	Długość gwintu 1.5 x D							0	
Длина резьбы 2 x D	Długość gwintu 2 x D							5	
Длина резьбы 2.5 x D	Długość gwintu 2.5 x D							6	
Износостойкое покрытие	Powłoka zabezpieczająca przed zużyciem								VS
Специальное исполнение	Specjalne wykonanie								SP

ПИКТОГРАММЫ – PIKTOGRAMY



Усиленный хвостовик по DIN 371
Chwył wzmożniony wg DIN 371



Утонченный хвостовик по DIN 376
Chwył przelotowy wg DIN 376



Быстрорежущая сталь с кобальтом HSSE
Stal kobaltowa HSSE



Порошковая быстрорежущая сталь HSSE-PM
Stal proszkowa ASP



Количество режущих кромок (Z)
Ilość ostrzy (Z)



Диаметр отверстия под резьбу
Średnica otworu



Прямые канавки
Proste rowki wiórowe



Прямые канавки с подточкой центра
Proste rowki wiórowe, skośna powierzchnia natarcia



Подточка центра
Skośna powierzchnia natarcia



Правые спиральные канавки 40°
40° rowki wiórowe prawoskrętne



Раскатчик
Wygniatak



Раскатчик с канавками подвода СОЖ
Wygniatak z rowkami smarowymi



Корончатый метчик
Gwintownik koronowy



Комбинированный сверло/метчик
Wiertło - gwintownik



Шахматный метчик
Nakrój przerywany



С увеличенным стружечным пространством
Nakrój obniżony



Внутренний подвод СОЖ с фронтальным выходом
Chłodzenie wewnętrzne z ujściem poosiowym



Внутренний подвод СОЖ с радиальным выходом
Chłodzenie wewnętrzne z ujściem promieniowym



Коническая резьба 1:16 (NPT - NPTF - Rc)
Gwint stożkowy 1:16 (NPT - NPTF - Rc)



Резьба EG
Gwint EG



Левая резьба
Gwint lewy



Для групп материалов согласно таблице DC

Dla grup materiałowych wg „Tabeli Zastosowań” DC Swiss



Сквозные отверстия, длинностружечные материалы
Otwór przelotowy, materiały z długim wiórem



Сквозные отверстия <1,5xD, короткостружечные материалы
Otwór przelotowy < 1.5 x D, materiały z krótkim wiórem



Глухие отверстия <1,5xD, длинностружечные материалы
Otwór ślepy < 1.5 x D, materiały z długim wiórem



Глухие отверстия <2,5xD, длинностружечные материалы
Otwór ślepy < 2.5 x D, materiały z krótkim wiórem



Сквозные/глухие отверстия >2,5xD
Otwór przelotowy/ślepy > 2.5 x D



Заходная часть 2-3 нитки, форма С
2-3 zwoi wprowadzających, форма C



Предварительный метчик
Gwintownik nr 1 - wstępny



Второй метчик
Gwintownik nr 2 - zgrubny



Чистовой метчик
Gwintownik nr 3 - wykańczający



Ручные метчики, комплект из 3-х шт.
Gwintowniki ręczne, zestaw 3 szt.



Класс точности ISO 2 6H
Tolerancja ISO 2 6H



Обработка поверхности DC „V”
DC Warpozycja „V”



Износостойкое покрытие DC
DC Powłoka zabezpieczająca przed zużyciem



Покрывание нитридом титана
Powłoka „TiN”



Покрывание карбонитридом титана
Powłoka „TiCN”



Азотированные (поверхностная твердость 1100HV)
Azotowanie (twardość powierzchni ok. 1100 HV)



Покрывание нитридом хрома
Powłoka „CrN”



Для классического нарезания резьбы
Do gwintowania standardowego



Для скоростного нарезания
Do gwintowania na sztywno

ГРУППЫ ПРИМЕНЯЕМОСТИ

GRUPY ZASTOSOWAŃ

Примеры для групп применяемости

Przykłady dla grup zastosowań

11 Автоматные стали 1.0711 9 S 20 1.0715 9 SMn 28 1.0718 9 SMnPb 28 1.0726 35 S 20 1.0737 9 SMnPb 36	12 Структурные/цементуемые стали 1.0037 St 37-2 (S235JR) 1.0050 St 50-2 (E295) 1.0060 St 60-2 (E335) 1.5919 15 CrNi6 1.7131 16 MnCr5	13 Углеродистые стали 1.0503 C 45 1.0535 C 55 1.0601 C 60 1.1545 C 105 W1 1.2067 100 Cr 6	14 Легированные стали <850 N/mm ² 1.2363 X100CrMoV5-1 1.3551 80MoCrV42-16 1.4922 X20CrMoV12-1 1.7218 25CrMo4 1.7220 34CrMo4	11 Stale szybko tnące 1.0711 1212 1.0715 1213 1.0718 12 L 13 1.0726 1140 1.0737 12 L 14	12 Stale konstrukcyjne/nawęglane 1.0037 1015 1.0050 1.0060 1.5919 4320 1.7131 5115	13 Stale węglowe 1.0503 1043 1.0535 1055 1.0601 1060 1.1545 W 110 1.2067 L 3	14 Stale stopowe <850 N/mm ² 1.2363 A 2 1.3551 M 50 1.4922 1.7218 4130 1.7220 4135
15 Легированные стали <850 N/mm ² 1.3553 X82WMoCrV6-5-4 1.6580 30CrNiMo8 1.7220 34CrMo4 1.7225 42CrMo4 1.8507 34CrAlMo5	16 Высокопрочные легированные стали EN-GJS-1200-2 1.6582 34CrNiMo6v 1.7225 42CrMo4v 1.7228 50CrMo4v 1.8515 31CrMo12v	21 Легкообрабатываемые нержавеющие стали 1.4005 X12CrS13 1.4006 X12Cr13 1.4016 X6Cr17 1.4104 X12CrMoS17 1.4305 X10CrNiS18 9	22 Аустенитные нержавеющие стали 1.4301 X5CrNi18 10 1.4406 X2CrNiMoN17 12 2 1.4435 X2CrNiMo18 14 3 1.4541 X6CrNiTi18 10 1.4571 X6CrNiMoTi17 12 2	15 Stale stopowe >850 - <1150 N/mm ² 1.3553 1.6580 1.7220 4135 1.7225 4140 1.8507 K 23510 (UNS)	16 Stale stopowe o dużej wytrzymałości EN-GJS-1200-2 1.6582 4340 1.7225 4140 1.7228 4147 1.8515	21 Stale automatowe nierdzewne 1.4005 416 1.4006 410 1.4016 430 1.4104 430 F 1.4305 303	22 Austeniczne stale nierdzewne 1.4301 304 1.4406 316 LN 1.4435 316 L 1.4541 321 1.4571 316 Ti
23 Ферритные и мартенситные <850 N/mm ² 1.4112 X90CrMoV18 1.4582 X4CrNiMoNb25 7 1.4762 X10CrAl24 1.4821 X20 CrNiSi25 4	24 Ферритные и мартенситные >850 - <1150 N/mm ² 1.4057 X20CrNi17 2 1.4125 X105CrMo17 1.4704 45 SiCr16 11 1.4748 X85CrMoV18 2	31 Чугун 0.6015 GG 15 0.6020 GG 20 0.6025 GG 25 0.6030 GG 30	32 Ковкий и высокопрочный чугун 0.7040 GGG 40 0.7043 GGG 40.3 0.7050 GGG 50 0.7060 GGG 60 0.7080 GGG 80	23 Stale ferrytyczne i martenzytyczne <850 N/mm ² 1.4112 440 B 1.4582 1.4762 446 1.4821	24 Stale ferrytyczne i martenzytyczne >850 - <1150 N/mm ² 1.4057 431 1.4125 440 C 1.4704 HNV 2 (SAE) 1.4748	31 Żeliwo szare 0.6015 A 48-25 B 0.6020 A 48-30 B 0.6025 A 48-40 B 0.6030 A 48-45 B	32 Żeliwo sferoidalne 0.7040 60-40-18 0.7043 0.7050 65-45-12 0.7060 80-55-06 0.7080 120-90-02
41 Чистый титан 3.7024 Grad 1 3.7034 Grad 2 3.7055 Grad 3 3.7065 Grad 4	42 Титановые сплавы 3.7124 Ti Cu 2.5 3.7164 Ti Al 6 V 4 (Grad 5) 3.7174 Ti Al 6 V 6 Sn2	51 Никелевые сплавы 1 <850 N/mm ² 1.3912 Ni36 (Invar) 2.4360 NiCu 30 Fe (Monel 400) 2.4816 NiCr 15 Fe (Inconel 600) 2.4876 X10NiCrAlTi32 20 Hastelloy	52 Никелевые сплавы 2 >850 - <1150 N/mm ² 2.4631 NiCr 20 TiAl (Nimonic 80) 2.4668 NiCr 19 NbMo (Inconel 718)	41 Czysty tytan 3.7024 Gr. 1 3.7034 Gr. 2 3.7055 Gr. 3 3.7065 Gr. 4	42 Stopy tytanu 3.7124 3.7164 Gr. 5 3.7174	51 Stopy niklu 1 <850 N/mm ² 1.3912 Invar 2.4360 Monel alloy 400 2.4816 Inconel alloy 600 2.4876 Incoloy alloy 800 Hastelloy	52 Stopy niklu 2 >850 - <1150 N/mm ² 2.4631 Nimonic alloy 80A 2.4668 Inconel alloy 718
53 Никелевые сплавы 3 >1150 - <1600 N/mm ² 2.4631 NiCr 20 TiAl (Nimonic 80) 2.4668 NiCr 19 NbMo (Inconel 718)	61 Чистая медь (электротехническая) 2.0060 E-Cu57 (E-Cu)	62 Короткостружечная латунь 2.0401 CuZn39Pb 3 (Ms58) 2.0402 CuZn40Pb 2 (Ms58) 2.1030 CuSn 8 (Bz) 2.1096 G-CuSn 5 ZnPb	63 Длинностружечная латунь 2.0240 CuZn15 (Ms85) 2.0265 CuZn30 (Ms70) 2.0321 CuZn37 (Ms63)	53 Stopy niklu 3 >1150 - <1600 N/mm ² 2.4631 Nimonic alloy 80A 2.4668 Inconel alloy 718	61 Czysta miedź (miedź elektrolityczna) 2.0060	62 Mosiądz z krótkim włókiem, brąz fosforowy, brąz armatni 2.0401 C 38500 2.0402 C 37800 2.1030 C 52100 2.1096	63 Mosiądz z długim włókiem 2.0240 C 2300 2.0265 C 26000 2.0321 C 27200
71 Нелегированный алюминий 3.0205 Al 99 3.0255 Al 99.5	72 Алюминий, Si < 1.5% 3.1255 AlCuSiMn 3.1355 AlCuMg 2 3.2315 AlMgSi 1 3.3206 AlMgSi 0.5 3.4345 AlZnMgCu 0.5	73 Алюминий, Si > 1.5% - 10% 3.2161 G-AlSi8Cu3 3.2162 GD-AlSi8Cu3 3.2341 G-AlSi5Mg 3.2371 G-AlSi7 Mg	74 Алюминий, Si >10%, сплавы магния 3.2381 G-AlSi10Mg 3.2382 GD-AlSi10Mg 3.2581 G-AlSi 12 3.2583 G-ALSi 12 (Cu)	71 Aluminium niestopowe 3.0205 1200 3.0255 1050 A	72 Stopy aluminium, Si < 1.5% 3.1255 2014 3.1355 2024 3.2315 6082 3.3206 6060 3.4345 7020	73 Stopy aluminium, Si > 1.5% - 10% 3.2161 A 380.1 3.2162 3.2341 3.2371 A 356.2	74 Stopy aluminium, Si >10%. Stopy magnezu 3.2381 A 360 3.2382 3.2581 A 413 3.2583 A 413.1
81 Термопластики Delrin (POM) Teflon Nylon	82 Дуропластики Bakelit Novopan	83 Стеклопластики Стеклопластики Термо- и Дуропластики	Стандарт: DIN	81 Tworzywa sztuczne - termoplasty Delrin (POM) Teflon Nylon	82 Tworzywa sztuczne - duroplasty Bakelit Novopan	83 Tworzywa sztuczne wzmacniane włóknem szklanym Duro i Termoplasty wzmacniane włóknem szklanym	Однесение: AISI/ASTM

ТАБЛИЦА ПРИМЕНЕНИЯ – TABELA ZASTOSOWAŃ

НАРЕЗАНИЕ РЕЗЬБЫ – GWINTOWANIE

Нарезание резьбы Nacinanie gwintu

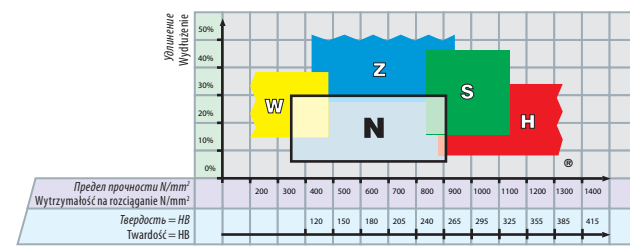

Нарезание резьбы Nacinanie gwintu

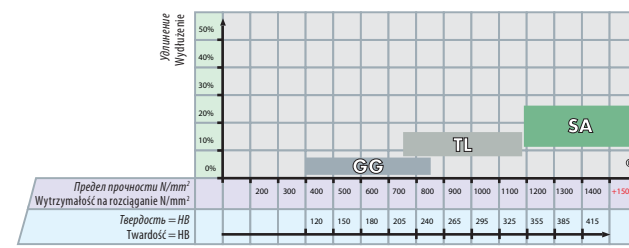

Скоростное нарезание резьбы Gwintowanie na sztywno

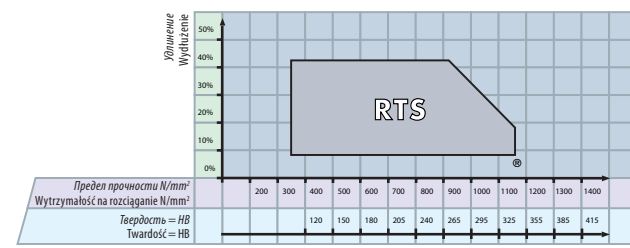

Формирование раскатниками Wygniatanie gwintu

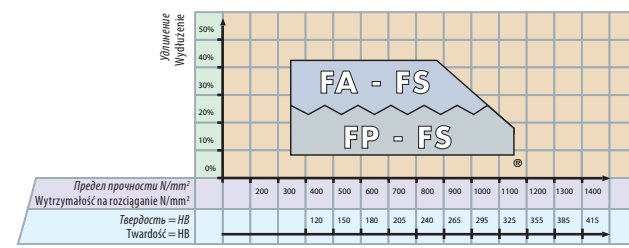

Классификация материалов Klasyfikacja materiału

Группы материалов Grupy materiałowe	Описание материалов	Оznaczenie materiału	Твердость Twardość (HB)	Предел прочности Wytrzymałość на разгибание Rm (N/mm ²)	Удлинение Wydłużenie A (%)
10 Стали Stale	11 Автоматные стали	Stale sztywnotnące	< 200	< 700	< 10
	12 Структурные/цементуемые стали	Stale konstrukcyjne/nawęglane	< 200	< 700	< 30
	13 Углеродистые стали	Stale węglowe	< 300	< 1000	< 20
	14 Легированные <850 N/mm ²	Stale stopowe <850 N/mm ²	< 250	< 850	< 30
	15 Легированные стали >850 - <1150 N/mm ²	Stale stopowe >850 - <1150 N/mm ²	> 250	> 850	< 30
	16 Высокопрочные легированные стали	Stale stopowe o dużej wytrzymałości	> 250	> 850	< 12
20 Нержавеющие стали Stale nierdzewne	21 Легкообрабатываемые нержавеющие стали	Stale automatowe nierdzewne	< 250	< 850	< 25
	22 Аустенитные нержавеющие стали	Austeniczne stale nierdzewne	< 250	< 850	> 20
	23 Ферритные и мартенситные <850 N/mm ²	Stale ferrytyczne i martenzytyczne <850 N/mm ²	< 250	< 850	> 20
	24 Ферритные и мартенситные >850 - <1150 N/mm ²	Stale ferrytyczne i martenzytyczne >850 - <1150 N/mm ²	> 250	> 850	> 15
30 Чугун Żeliwo szare	31 Чугун	Żeliwo szare	< 250	< 850	< 10
	32 Ковкий и высокопрочный чугун	Żeliwo sferoidalne	< 250	< 850	> 10
40 Титан Tytan	41 Чистый титан	Czysty tytan	< 250	< 850	> 20
	42 Титановые сплавы	Stopy tytanu	> 250	> 850	< 20
50 Никель Nikiel	51 Никелевые сплавы 1 <850 N/mm ²	Stopy niklu 1 <850 N/mm ²	< 250	< 850	> 25
	52 Никелевые сплавы 2 >850 - <1150 N/mm ²	Stopy niklu 2 >850 - <1150 N/mm ²	> 250	> 850	< 25
	53 Никелевые сплавы 3 >1150 - ≤1600 N/mm ²	Stopy niklu 3 >1150 - ≤1600 N/mm ²	> 340	> 1150	< 20
60 Медь Miedź	61 Чистая медь (электротехническая)	Czysta miedź (miedź elektrolityczna)	< 120	< 400	> 12
	62 Короткопружечная латунь	Mosiądz z krótkim wiórem, brąz fosforowy, brąz armatni	< 200	< 700	< 12
	63 Длиннопружечная латунь	Mosiądz z długim wiórem	< 200	< 700	> 12
70 Алюминий, Магний Aluminium, Magnez	71 Нелегированный алюминий	Aluminium niestopowe	< 100	< 350	> 15
	72 Алюминий Si < 1.5 %	Stopy aluminium, Si < 1.5 %	< 150	< 500	> 15
	73 Алюминий Si > 1.5 % - < 10 %	Stopy aluminium, Si > 1.5 % - < 10 %	< 120	< 400	< 15
	74 Алюминий Si > 10 %, сплавы магния	Stopy aluminium, Si > 10 %, Stopy magnezu	< 120	< 400	< 10
80 Сложные пластики, композиты Tworzywa sztuczne	81 Термопластики	Tworzywa sztuczne - termoplasty	-	-	-
	82 Дуропластики	Tworzywa sztuczne - duroplasty	-	-	-
	83 Стеклопластики	Tworzywa sztuczne wzmacniane włóknem szklanym	-	-	-

Со страницы :
Od strony :

M
MF
UNC (UNJC)
UNF (UNJF)
UNEF/UN/UNS
G/Rp/Rc
NPT/NPTF
W
PG/TR
EG M/EG UN

N Нормальные материалы Materiały normalne												W Мягкие материалы Materiały miękkie		
22	22	24	24	24	30	30	32	32	34	34	34	34	46	47
81	80	81	81				87		88	88	88			
108	108	108							110	110				
128	128	128							130	130				
144	144								145	145				
150	151	151	151						152	152	152			153
164														
160	160													
166	166													
	170	170							171	171				

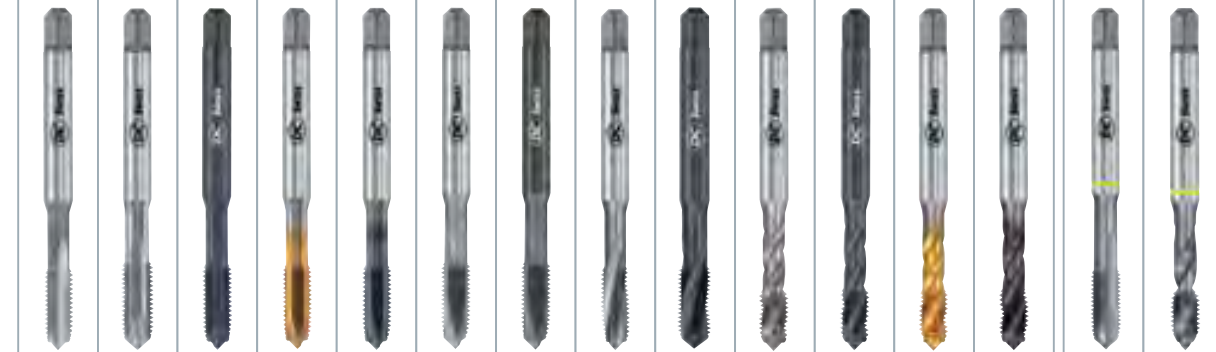

Vc (m/min)	
< Ø 20 mm Стандартный Standard +V / +NI	Спокрываем Powlekanie TN / TC / VS
10 - 15	20 - 30
10 - 15	20 - 30
8 - 12	16 - 24
8 - 12	16 - 24
3 - 5	6 - 12
3 - 5	3 - 5
10 - 15	20 - 30
4 - 8	8 - 16
4 - 8	8 - 16
3 - 5	6 - 12
10 - 15	20 - 30
10 - 15	20 - 30
4 - 8	3 - 5
3 - 5	3 - 5
3 - 5	6 - 12
3 - 5	4 - 8
2 - 3	
8 - 12	8 - 16
20 - 30	
16 - 24	
10 - 15	
20 - 30	
10 - 15	20 - 30
10 - 15	20 - 30
20 - 30	
8 - 16	16 - 24
4 - 8	8 - 16

N 10	N 20	N 20V	N 20TN	N 20TC	N 30	N 30V	N 50	N 50V	N 60	N 60V	N 60TN	N 60TC	W 20	W 60
SE	SE	SE	SE	SE	SE	SE	SE	SE	SE	SE	SE	SE		
SE	SE	SE	SE	SE	SE	SE	SE	SE	SE	SE	SE	SE		
SE	SE	SE	SE	SE	SE	SE	SE	SE	SE	SE	SE	SE		
SE	SE	SE	SE	SE	SE	SE	SE	SE	SE	SE	SE	SE		
E		E	E							E	E			
SE	SE	SE	SE				SE		SE	SE	SE			
S							S		S				S	S
SE							SE		SE	SE			SE	SE
SE				S			SE		SE					
	S			S					S				S	S
SE	SE			SE					SE				SE	SE
				E	E				E		E	E		
E				E	E				E		E			
	E								E				E	E
				E								E		
				E								E		

СКОРОСТНОЕ НАРЕЗАНИЕ РЕЗЬБЫ С ЧПУ – GWINTOWANIE NA SZTYWNO



264/265

Со страницы Od strony :
M
MF
UNC
UNF
UNEF/UN/UNS
G/Rp/Rc
NPT/NPTF
W
PG/TR
EG M/EG UN

RTS				Z
Скоростное нарезание резьбы с ЧПУ Gwintowanie na sztywno				
62	62	63	63	50
98		98		
120		120		
140		140		
		155		

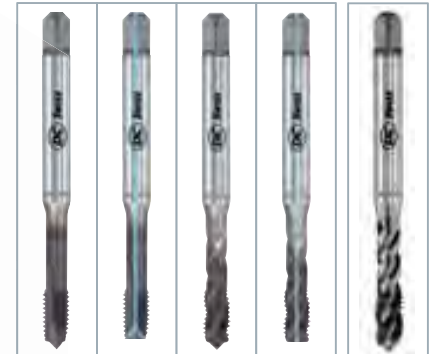

Vc (m/min) < Ø 20 mm (Guide line) Спокрываем VS Powlekania VS	RTS-20VS	RTS-23VS	RTS-62VS	RTS-65VS	Z-70VS	
40 – 60	E	E	E	E		11
40 – 60	E	E	E	E		12
30 – 50	E	E	E	E		13
16 – 24	E	E	E	E	E	14
6 – 12	E	E	E	E	E	15
						16
20 – 40	E	E	E	E		21
8 – 16	E	E	E	E	E	22
8 – 16					E	23
6 – 12					E	24
20 – 40	E	E	E	E		31
20 – 40	E	E	E	E		32
						41
						42
6 – 12					S	51
4 – 8					S	52
						53
8 – 16	E	E	E	E	E	61
						62
20 – 40	E	E	E	E		63
						71
40 – 150	E	E	E	E		72
30 – 100	E	E	E	E		73
30 – 100	E	E	E	E		74
						81
						82
						83

S Оптимально с маслом
S Допустимо с маслом

S Optymalne z chłodzeniem olejowym
S Możliwe z chłodzeniem olejowym

E Оптимально с эмульсией
E Допустимо с эмульсией

E Optymalne z chłodzeniem emulsją
E Możliwe z chłodzeniem emulsją

- ▶ **Нарезание резьбы** 1
- ▶ **Gwintowanie**
M, MF, UNC, UNC(J), UNF, UNF(J),
UNEF, UN, UNS, G, Rp, Rc, NPT, NPTF, W,
PG, TR, EG M, EG UN

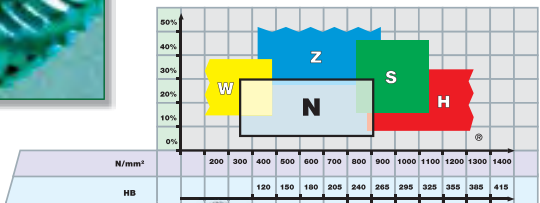

- ▶ **Скоростное нарезание резьбы** 1
- ▶ **Gwintowanie na sztywno**
M, MF, UNC, UNF, G

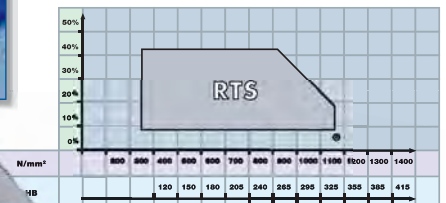
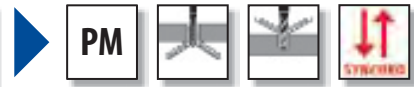

RTS
Rigid Tapping Synchro



- ▶ **Плшки** 2
- ▶ **Narzynki**
M, MF, UNC, UNF, UNEF, UN, UNS, G, R,
NPT, NPTF, W, PG, TR



NI

Образование резьбы раскатниками 1

Wygniatanie Gwintów

M, MF, UNC, UNF, G

PM

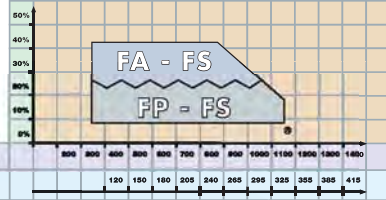

FORMING



Фрезерование резьбы 2

Frezowanie Gwintów

M, MF, UNC, UNF, UN, G, PG, NPT, NPTF

VHM
CAR

1.5 x Ø

2 x Ø

2.5 x Ø

GF - GFH HRC ≤ 63 -

GFS - GFM - BGF



Образование резьбы раскатниками 2

Sprawdziany do Gwintów

M, MF, UNC, UNF, UNEF, UN, UNS, G, R, Rp, Rc, PG, NPT, NPTF, EG M, EG UNC, EG UNF

TiCN



Резьбонарезные патроны SRT 2

- Твердосплавные спиральные сверла
- Плашкодержатели
- Таблицы: скорости резания, перевод дюйм/мм, диаметр отверстий под резьбу, диаметры под плашки
- Технические анкеты
- Общие условия

- Оправки до gwintowania SRT
- Wiertła pełnowęglkowe
- Оправки do narzynek
- Prędkości skrawania, przeliczniki, średnice otworów, tabele średnic wałków
- Kwestionariusze techniczne
- Ogólne warunki





































M
MF
UNC, UNC(J)
UNF, UNF(J),
UNEF, UN, UNS
G, Rp, Rc, W
NPT, NPTF,
PG, TR

























EG M, EG UN



























Корончатые метчики
Gwintowniki koronowe























Комбинированные
сверла/метчики
Wiertło-gwintowniki

		N						
Характеристики Cechy charakterystyczne				 V	 TiN	 TiCN		
Типы отверстий Typ otworu								
		N310-3	N320-3 N320-4	N320V-3 N320V-4	N320TN-3 N320TN-4	N320TC-4	N321-3 N321-4	N330-3 N330-4
Длинный по DIN DIN długi	DIN 371	22	22/24	24	24	24	30	30
Особо длинный Extra-długi	DIN 371							
Короткий по ISO ISO krótki	ISO 529							
Длинный по DIN DIN długi	~DIN 2174							
Класс точности Tolerancja	ISO 2 6H/HX	22	22/24	24	24	24	30	30
Класс точности Nadwymiar	ISO 3 6G		28	28				
Класс точности Nadwymiar	7G		28					
Класс точности Nadwymiar	+ 0.10 mm		28					
Класс точности Nadwymiar	+ 0.20 mm		30					
Повышенный класс точности Tolerancja dokładna	ISO 1 4H		26					
Левая резьба LH Gwint lewy	ISO 2 6H	22	26	26				
		N410-3	N420-4	N420V-4	N420TN-4	N420TC-4	N421-4	N430-4
Длинный по DIN DIN długi	DIN 376	23	25	25	25	25	31	31
Особо длинный Extra-długi	DIN 376							
Короткий по ISO ISO krótki	ISO 529							
Длинный по ISO ISO długi	ISO 2283							
Класс точности Tolerancja	ISO 2 6H/HX	23	25	25	25	25	31	31
Класс точности Nadwymiar	ISO 3 6G		29	29				
Класс точности Nadwymiar	7G		29					
Класс точности Nadwymiar	+ 0.10 mm		29					
Класс точности Nadwymiar	+ 0.20 mm		31					
Повышенный класс точности Tolerancja dokładna	ISO 1 4H		27					
Левая резьба LH Gwint lewy	ISO 2 6H	23	27	27				

N								
								
								
								
								
N330V-3 N330V-4	N350-3	N350V-3	N360-3	N360V-3	N360TN-3	N360TC-3	N360-5	N360V-5
30	32	32	34	34	34	34	40	40
30	32	32	34	34	34	34	40	40
			36	36				
			38	38				
			38					
			38					
			36	36				
N430V-4	N450-3	N450V-3	N460-3	N460V-3	N460TN-3	N460TC-3	N460-5	N460V-5
31	33	33	35	35	35	35	41	41
31	33	33	35	35	35	35	41	41
			37	37				
			39	39				
			39					
			37	37				











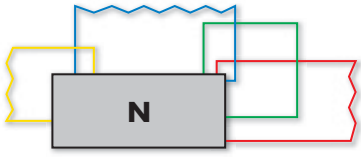







		N							
Характеристики Cechy charakterystyczne		 R40	 R40		 V	 TiN	 R40	 R40	 V
						 NEW			
Типы отверстий Typ otworu									
		N361-3	N362V-3	N520-4	N520V-4	N520TN-4	N560-3	N560V-3	
Длинный по DIN DIN długi	DIN 371	40	40						
Особо длинный Extra-długi	DIN 371			42	42	42	44	44	
Короткий по ISO ISO krótki	ISO 529								
Длинный по DIN DIN długi	~DIN 2174								
Класс точности Tolerancja	ISO 2 6H/HX	40	40	42	42	42	44	44	
Класс точности Nadwymiar	ISO 3 6G								
Класс точности Nadwymiar	7G								
Класс точности Nadwymiar	+ 0.10 mm								
Класс точности Nadwymiar	+ 0.20 mm								
Повышенный класс точности Tolerancja dokładna	ISO 1 4H								
Левая резьба LH Gwint lewy	ISO 2 6H								
		N461-3	N462V-3	N620-4	N620V-4	N620TN-4	N660-3	N660V-3	
Длинный по DIN DIN długi	DIN 376	41	41						
Особо длинный Extra-długi	DIN 376			43	43	43	45	45	
Короткий по ISO ISO krótki	ISO 529								
Длинный по ISO ISO długi	ISO 2283								
Класс точности Tolerancja	ISO 2 6H/HX	41	41	43	43	43	45	45	
Класс точности Nadwymiar	ISO 3 6G								
Класс точности Nadwymiar	7G								
Класс точности Nadwymiar	+ 0.10 mm								
Класс точности Nadwymiar	+ 0.20 mm								
Повышенный класс точности Tolerancja dokładna	ISO 1 4H								
Левая резьба LH Gwint lewy	ISO 2 6H								

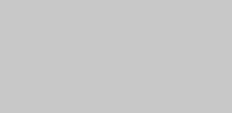









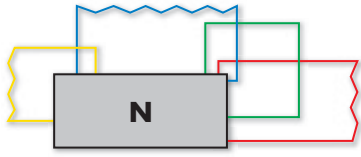

N			W		Z			
 TiN								
								
								
N560TN-3	N1120-4 N1121-4	N1110 -1-2-3-S	W320-3 W320-4	W360-3	Z320V-3 Z320V-4	Z320VS-4	Z360V-3 Z362V-3	Z360VS-3 Z362VS-3
44	72	74	46	47	48	48	50	50
44	72	74	46	47	48	48	50	50
							50	
N660TN-3	N1220-4 N1221-4	N1210 -1-2-3-S	W420-4	W460-3	Z420V-4	Z420VS-4	Z462V-3	Z462VS-3
45	72	75	46	47	49	49	51	51
45	72	75	46	47	49	49	51	51
							51	

		Z	H				S	
Характеристики Cechy charakterystyczne		 VS		 TiCN		 TiCN	 VS	 VS
		 NEW						
Типы отверстий Typ otworu								
		Z370VS-3	H320-4	H320TC-4	H350-3	H350TC-3	S320VS-4	S360VS-3
Длинный по DIN DIN długi	DIN 371	50	52	52	54	54	56	56
Особо длинный Extra-długi	DIN 371							
Короткий по ISO ISO krótki	ISO 529							
Длинный по DIN DIN długi	~DIN 2174							
Класс точности Tolerancja	ISO 2 6H		52	52	54	54		
Класс точности Tolerancja	6HX	50					56	56
Повышенный класс точности Tolerancja dokładna	4HX							
Класс точности Nadwymiar	ISO 3 6G				54			
Класс точности Nadwymiar	6GX							
Повышенный класс точности Tolerancja dokładna	ISO 1 4H							
Левая резьба LH Gwint lewy	ISO 2 6H							
		Z470VS-3	H420-4	H420TC-4	H450-3	H450TC-3	S420VS-4	S460VS-3
Длинный по DIN DIN długi	DIN 376	51	53	53	55	55	56	56
Особо длинный Extra-długi	DIN 376							
Короткий по ISO ISO krótki	ISO 529							
Длинный по DIN DIN długi	~DIN 2174							
Класс точности Tolerancja	ISO 2 6H		53	53	55	55		
Класс точности Tolerancja	6HX	51					56	56
Повышенный класс точности Tolerancja dokładna	4HX							
Класс точности Nadwymiar	ISO 3 6G				55			
Класс точности Nadwymiar	6GX							
Повышенный класс точности Tolerancja dokładna	ISO 1 4H							
Левая резьба LH Gwint lewy	ISO 2 6H							

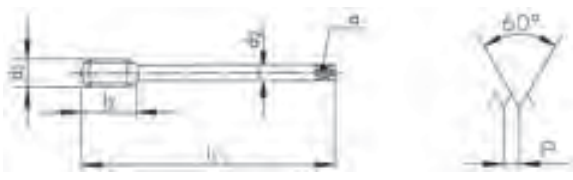







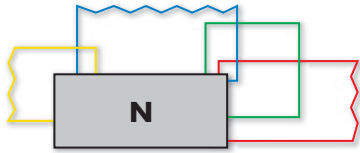



		RTS						
Характеристики Cechy charakterystyczne								
		VS	VS	VS	VS	VS	VS	VS
							NEW	
Типы отверстий Typ otworu								
		RTS320VS-4	RTS323VS-4	RTS362VS-3	RTS365VS-3	RTS362VS-5	RTS365VS-5	RTS523VS-4
Длинный по DIN DIN długi	DIN 371	62	62	63	63	64	64	
Особо длинный Extra-długi	DIN 371							65
Короткий по ISO ISO krótki	ISO 529							
Длинный по DIN DIN długi	~DIN 2174							
Класс точности Tolerancja	ISO 2 6H							
Класс точности Tolerancja	6HX	62	62	63	63	64	64	65
Повышенный класс точности Tolerancja dokładna	4HX							
Класс точности Nadwymiar	ISO 3 6G							
Класс точности Nadwymiar	6GX			64				
Повышенный класс точности Tolerancja dokładna	ISO 1 4H							
Левая резьба LH Gwint lewy	ISO 2 6H							
		RTS420VS-4	RTS423VS-4	RTS462VS-3	RTS465VS-3			RTS623VS-4
Длинный по DIN DIN długi	DIN 376	62	62	63	63			
Особо длинный Extra-długi	DIN 376							65
Короткий по ISO ISO krótki	ISO 529							
Длинный по DIN DIN długi	~DIN 2174							
Класс точности Tolerancja	ISO 2 6H							
Класс точности Nadwymiar	6HX	62	62	63	63			65
Повышенный класс точности Tolerancja dokładna	4HX							
Класс точности Nadwymiar	ISO 3 6G							
Класс точности Nadwymiar	6GX							
Повышенный класс точности Tolerancja dokładna	ISO 1 4H							
Левая резьба LH Gwint lewy	ISO 2 6H							

RTS		FS		FP				FA	
	VS								
RTS565VS-3	FS380VS-5 FS380VS-3	FP380CN-3	FP381CN-3	FP380VS-3	FP381VS-3	FP384VS-3	FA381VS-3	FA384VS-3	
65									
	66	67	67	67	68	69	70	71	
65	66	67	67	67	68	69	70	71	
	66			67	68		70		
RTS665VS-3					FP481VS-3	FP484VS-3	FA481VS-3	FA484VS-3	
65									
					68	69	70	71	
65					68	69	70	71	
					68		70		

									N310-3	N310-3 LH	N320-3	
												
N310-3												
N310-3 LH	 LH											
N320-3												
												
												
Ø d ₁ M	P mm	l ₁ mm	l ₂ mm	l ₃ mm	d ₂ mm	a mm			ID	ID	ID	
1	0.25	40	5.5		2.5	2.1	2	0.75			111467	
1.1	0.25	40	5.5		2.5	2.1	2	0.85			111468	
1.2	0.25	40	5.5		2.5	2.1	2	0.95			111469	
1.4	0.30	40	7.0		2.5	2.1	2	1.10			111470	
1.5	0.30	40	7.0		2.5	2.1	2	1.20			111471	
1.6	0.35	40	8.0		2.5	2.1	2	1.25			101454	
1.7	0.35	40	8.0		2.5	2.1	2	1.35			101455	
1.8	0.35	40	8.0		2.5	2.1	2	1.45			101456	
2	0.40	45	8.0		2.8	2.1	*3	1.60	101439	111460	101458	
2.2	0.45	45	9.0		2.8	2.1	2	1.75			101459	
2.3	0.40	45	9.0		2.8	2.1	2	1.90			101460	
2.5	0.45	50	10.0		2.8	2.1	*3	2.05	101440	111461	101461	
2.6	0.45	50	10.0		2.8	2.1	3	2.15	101441			
3	0.50	56	12.0	18	3.5	2.7	*3	2.50	101442	111462	101462	
3.5	0.60	56	13.0	20	4.0	3.0	*3	2.90	101443		101463	
4	0.70	63	14.0	21	4.5	3.4	*3	3.30	101444	111464	101464	
5	0.80	70	15.0	25	6.0	4.9	*3	4.20	101445	111465	101465	
6	1.00	80	17.0	30	6.0	4.9	*3	5.00	101446	111466	101466	
8	1.25	90	20.0	35	8.0	6.2	3	6.80	101447			
10	1.50	100	22.0	39	10.0	8.0	3	8.50	101438			
<p>* N320-3 =  2</p>									<p>≤ M1.5 </p>			



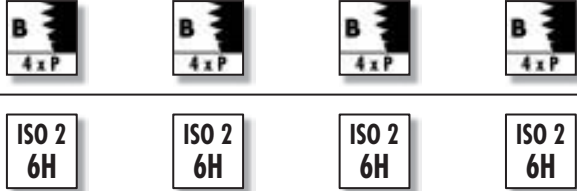







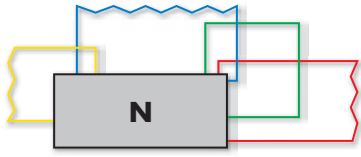

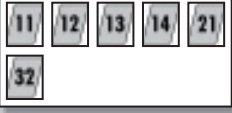

								N410-3	N410-3 LH						
								 							
N410-3															
N410-3 LH	 LH														
								 							
								 							
∅ d ₁ M	P mm	l ₁ mm	l ₂ mm	d ₂ mm	α mm			ID	ID						
3	0.50	56	12.0	2.2	1.8	3	2.50	101897							
4	0.70	63	14.0	2.8	2.1	3	3.30	101924							
5	0.80	70	15.0	3.5	2.7	3	4.20	101942							
6	1.00	80	17.0	4.5	3.4	3	5.00	101953							
7	1.00	80	17.0	5.5	4.3	3	6.00	142645	111491						
8	1.25	90	20.0	6.0	4.9	3	6.80	101958	111492						
10	1.50	100	22.0	7.0	5.5	3	8.50	101866	111478						
12	1.75	110	24.0	9.0	7.0	3	10.20	101870	111479						
14	2.00	110	28.0	11.0	9.0	3	12.00	101874	111480						
16	2.00	110	30.0	12.0	9.0	3	14.00	101880	111481						
18	2.50	125	33.0	14.0	11.0	3	15.50	101883	111482						
20	2.50	140	36.0	16.0	12.0	3	17.50	101885	125530						
22	2.50	140	36.0	18.0	14.5	3	19.50	101888							
24	3.00	160	39.0	18.0	14.5	4	21.00	101891	111485						
27	3.00	160	42.0	20.0	16.0	4	24.00	101895	111486						
30	3.50	180	45.0	22.0	18.0	4	26.50	101901	111487						
33	3.50	180	48.0	25.0	20.0	4	29.50	101907							
36	4.00	200	51.0	28.0	22.0	4	32.00	101915	111488						
39	4.00	200	55.0	32.0	24.0	4	35.00	101922							
42	4.50	200	55.0	32.0	24.0	4	37.50	101932							
45	4.50	220	59.0	36.0	29.0	4	40.50	* 111446							
48	5.00	250	63.0	36.0	29.0	4	43.00	111489							
56	5.50	280	71.0	45.0	35.0	5	50.50	111447							





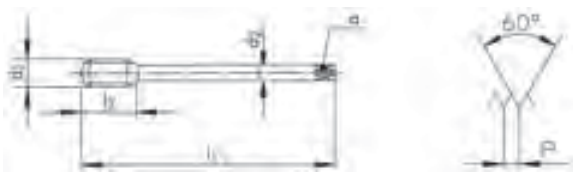



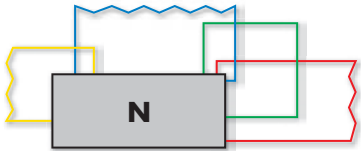

									N320-4	N320V-4	N320TN-4	N320TC-4
<p>N320-4  </p> <p>N320V-4  V </p> <p>N320TN-4  TiN </p> <p>N320TC-4  TiCN </p>												
												
												
Ø d ₁ M	P mm	l ₁ mm	l ₂ mm	l ₃ mm	d ₂ mm	α mm			ID	ID	ID	ID
* 2	0.40	45	8.0		2.8	2.1	2	1.60		101536	101528	
2.5	0.45	50	10.0		2.8	2.1	3	2.05	101483	101545	101530	101522
2.6	0.45	50	10.0		2.8	2.1	3	2.15	101484			
3	0.50	56	12.0	18	3.5	2.7	3	2.50	101485	101546	101531	101523
3.5	0.60	56	13.0	20	4.0	3.0	3	2.90	101491	101547		
4	0.70	63	14.0	21	4.5	3.4	3	3.30	101495	101548	101532	101524
5	0.80	70	15.0	25	6.0	4.9	3	4.20	101499	101549	101533	101525
6	1.00	80	17.0	30	6.0	4.9	3	5.00	101503	101550	101534	101526
8	1.25	90	20.0	35	8.0	6.2	3	6.80	101506	101551	101535	101527
10	1.50	100	22.0	39	10.0	8.0	3	8.50	101481	101544	101529	101521

* N320V-3 / N320TN-3



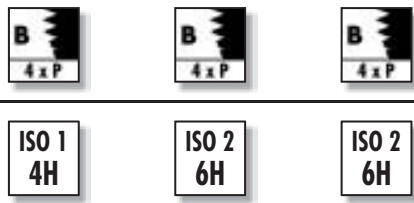







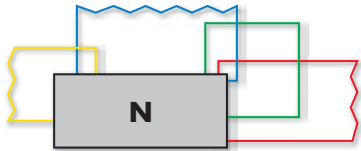















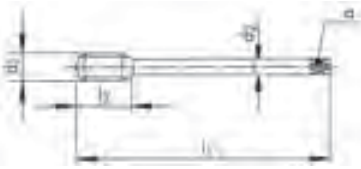













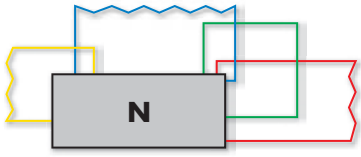

								N420-4	N420V-4	N420TN-4	N420TC-4
											
N420-4											
N420V-4	 V										
N420TN-4	 TiN										
N420TC-4	 TiCN										
											
											
Ø d ₁ M	P mm	l ₁ mm	l ₂ mm	d ₂ mm	α mm			ID	ID	ID	ID
3	0.50	56	12.0	2.2	1.8	3	2.50	102119			
4	0.70	63	14.0	2.8	2.1	3	3.30	102146	102279		
5	0.80	70	15.0	3.5	2.7	3	4.20	102171	102280		
6	1.00	80	17.0	4.5	3.4	3	5.00	102182	102282		
7	1.00	80	17.0	5.5	4.3	3	6.00	102189			
8	1.25	90	20.0	6.0	4.9	3	6.80	102195	102285	102251	102233
9	1.25	90	20.0	7.0	5.5	3	7.80	102202			
10	1.50	100	22.0	7.0	5.5	3	8.50	102061	102263	102240	102228
11	1.50	100	19.0	8.0	6.2	3	9.50	162770			
12	1.75	110	24.0	9.0	7.0	3	10.20	102072	102265	102243	102229
14	2.00	110	28.0	11.0	9.0	3	12.00	102081	102267	102245	
16	2.00	110	30.0	12.0	9.0	3	14.00	102090	102269	102247	102231
18	2.50	125	33.0	14.0	11.0	3	15.50	102097	102271		
20	2.50	140	36.0	16.0	12.0	3	17.50	102101	102273	102248	
22	2.50	140	36.0	18.0	14.5	3	19.50	102106	102275		
24	3.00	160	39.0	18.0	14.5	4	21.00	102110	102278		
27	3.00	160	42.0	20.0	16.0	4	24.00	102117	143856		
30	3.50	180	45.0	22.0	18.0	4	26.50	102124	105124		
33	3.50	180	48.0	25.0	20.0	4	29.50	102130	146968		
36	4.00	200	51.0	28.0	22.0	4	32.00	102137	143430		
39	4.00	200	55.0	32.0	24.0	4	35.00	102144	158724		
42	4.50	200	55.0	32.0	24.0	4	37.50	102158	143107		
45	4.50	220	59.0	36.0	29.0	4	40.50	* 110225			
48	5.00	250	63.0	36.0	29.0	4	43.00	110226	157517		
52	5.00	250	67.0	40.0	32.0	4	47.00	* 110227			
56	5.50	280	71.0	45.0	35.0	5	50.50	110229	158178		

										N320-4	N320-4 LH	N320V-4 LH	
													
N320-4													
N320-4 LH		LH											
N320V-4 LH		V	LH										NEW
													
										ISO 1 4H	ISO 2 6H	ISO 2 6H	
Ø d ₁	P	l ₁	l ₂	l ₃	d ₂	a				ID	ID	ID	
M	mm	mm	mm	mm	mm	mm		→ ←					
* 2	0.40	45	8.0		2.8	2.1	2	1.60		162503	111472	162771	
2.5	0.45	50	10.0		2.8	2.1	3	2.05		159345			
3	0.50	56	12.0	18	3.5	2.7	3	2.50		101487	111473	162772	
4	0.70	63	14.0	21	4.5	3.4	3	3.30		101493	111474	162773	
5	0.80	70	15.0	25	6.0	4.9	3	4.20		101497	111475	162774	
6	1.00	80	17.0	30	6.0	4.9	3	5.00		101501	111476	162775	
8	1.25	90	20.0	35	8.0	6.2	3	6.80	Δ	146482			
10	1.50	100	22.0	39	10.0	8.0	3	8.50		146484			

* 











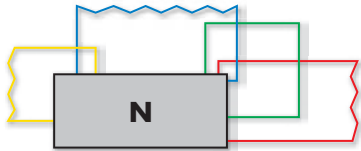







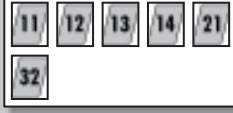

Δ ISO 1 4H =  6.70

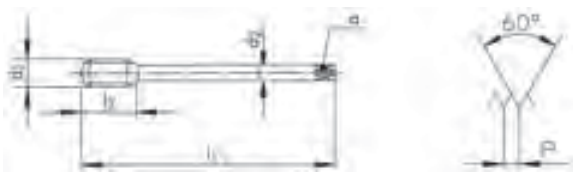









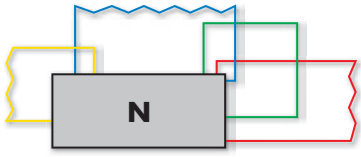



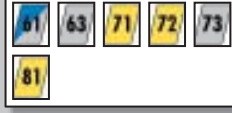

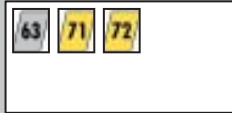

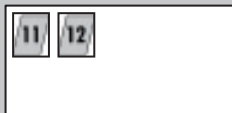
									N420-4	N420-4 LH	N420V-4 LH																																																																																											
									N420-4  																																																																																													
N420-4 LH  LH 																																																																																																						
N420V-4 LH  V LH 																																																																																																						
 																																																																																																						
	ISO 1 4H	ISO 2 6H	ISO 2 6H																																																																																																			
<table border="1"> <thead> <tr> <th>∅ d₁ M</th> <th>P mm</th> <th>l₁ mm</th> <th>l₂ mm</th> <th>d₂ mm</th> <th>a mm</th> <th></th> <th></th> <th>ID</th> <th>ID</th> <th>ID</th> </tr> </thead> <tbody> <tr><td>8</td><td>1.25</td><td>90</td><td>20.0</td><td>6.0</td><td>4.9</td><td>3</td><td>Δ 6.80</td><td>102193</td><td>102198</td><td>142621</td></tr> <tr><td>10</td><td>1.50</td><td>100</td><td>22.0</td><td>7.0</td><td>5.5</td><td>3</td><td>8.50</td><td>102059</td><td>102064</td><td>143287</td></tr> <tr><td>12</td><td>1.75</td><td>110</td><td>24.0</td><td>9.0</td><td>7.0</td><td>3</td><td>10.20</td><td>102070</td><td>102040</td><td>146583</td></tr> <tr><td>14</td><td>2.00</td><td>110</td><td>28.0</td><td>11.0</td><td>9.0</td><td>3</td><td>12.00</td><td></td><td>102084</td><td>146563</td></tr> <tr><td>16</td><td>2.00</td><td>110</td><td>30.0</td><td>12.0</td><td>9.0</td><td>3</td><td>14.00</td><td></td><td>102093</td><td>143108</td></tr> <tr><td>20</td><td>2.50</td><td>140</td><td>36.0</td><td>16.0</td><td>12.0</td><td>3</td><td>17.50</td><td></td><td>102103</td><td>145579</td></tr> <tr><td>24</td><td>3.00</td><td>160</td><td>39.0</td><td>18.0</td><td>14.5</td><td>4</td><td>21.00</td><td></td><td>111493</td><td></td></tr> <tr><td>30</td><td>3.50</td><td>180</td><td>45.0</td><td>22.0</td><td>18.0</td><td>4</td><td>26.50</td><td></td><td>111494</td><td></td></tr> </tbody> </table>	∅ d ₁ M	P mm	l ₁ mm	l ₂ mm	d ₂ mm	a mm			ID	ID	ID	8	1.25	90	20.0	6.0	4.9	3	Δ 6.80	102193	102198	142621	10	1.50	100	22.0	7.0	5.5	3	8.50	102059	102064	143287	12	1.75	110	24.0	9.0	7.0	3	10.20	102070	102040	146583	14	2.00	110	28.0	11.0	9.0	3	12.00		102084	146563	16	2.00	110	30.0	12.0	9.0	3	14.00		102093	143108	20	2.50	140	36.0	16.0	12.0	3	17.50		102103	145579	24	3.00	160	39.0	18.0	14.5	4	21.00		111493		30	3.50	180	45.0	22.0	18.0	4	26.50		111494				
∅ d ₁ M	P mm	l ₁ mm	l ₂ mm	d ₂ mm	a mm			ID	ID	ID																																																																																												
8	1.25	90	20.0	6.0	4.9	3	Δ 6.80	102193	102198	142621																																																																																												
10	1.50	100	22.0	7.0	5.5	3	8.50	102059	102064	143287																																																																																												
12	1.75	110	24.0	9.0	7.0	3	10.20	102070	102040	146583																																																																																												
14	2.00	110	28.0	11.0	9.0	3	12.00		102084	146563																																																																																												
16	2.00	110	30.0	12.0	9.0	3	14.00		102093	143108																																																																																												
20	2.50	140	36.0	16.0	12.0	3	17.50		102103	145579																																																																																												
24	3.00	160	39.0	18.0	14.5	4	21.00		111493																																																																																													
30	3.50	180	45.0	22.0	18.0	4	26.50		111494																																																																																													
 = 6.70																																																																																																						











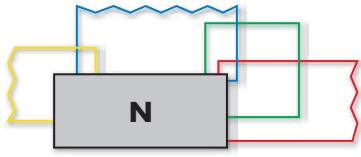

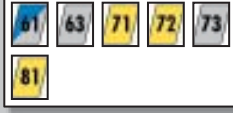

										N320-4	N320V-4	N320-4	N320-4
													
N320-4   													
N320V-4  V  													
													
													
Ø d ₁ M	P mm	l ₁ mm	l ₂ mm	l ₃ mm	d ₂ mm	α mm		6H → ←	ID	ID	ID	ID	
* 2	0.40	45	8.0		2.8	2.1	2	1.60	101457	6H + mm			
2.5	0.45	50	10.0		2.8	2.1	3	2.05	101482	6H + mm			
3	0.50	56	12.0	18	3.5	2.7	3	2.50	101486	6H + mm	143116	0.020	101489 0.036 101488
3.5	0.60	56	13.0	20	4.0	3.0	3	2.95	101490	6H + mm			
4	0.70	63	14.0	21	4.5	3.4	3	3.35	101494	6H + mm	143087	0.022	101496 0.041 111522
5	0.80	70	15.0	25	6.0	4.9	3	4.25	101498	6H + mm	143088	0.024	101500 0.044 111523
6	1.00	80	17.0	30	6.0	4.9	3	5.00	101502	6H + mm	143089	0.026	101504 0.050 111524
8	1.25	90	20.0	35	8.0	6.2	3	6.80	101505	6H + mm	143604	0.028	

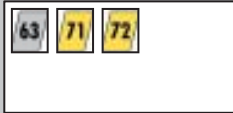

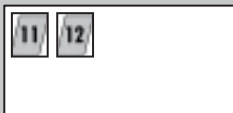

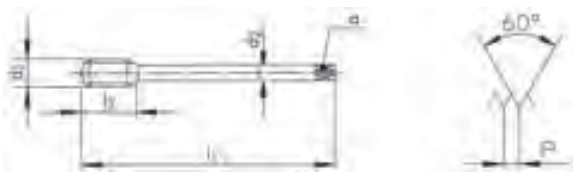





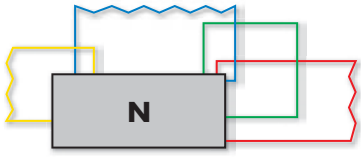







* N320-3











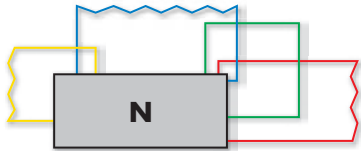



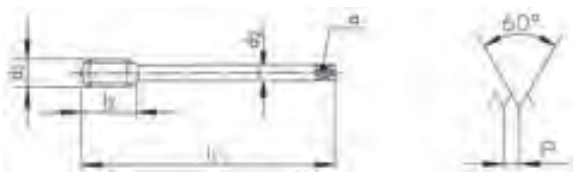

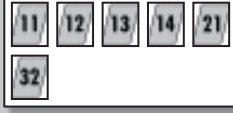









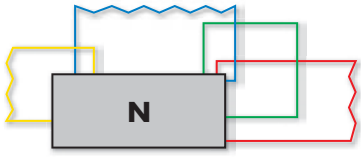





									N420-4	N420V-4	N420-4	N420-4																																																																								
									N420-4  																																																																											
N420V-4  V 																																																																																				
																																																																																				
	ISO 3 6G	ISO 3 6G	7G	6H +0.1mm																																																																																
<table border="1"> <thead> <tr> <th>$\varnothing d_1$</th> <th>P</th> <th>l_1</th> <th>l_2</th> <th>d_2</th> <th>α</th> <th></th> <th>$\pm 6H$</th> </tr> <tr> <th>M</th> <th>mm</th> <th>mm</th> <th>mm</th> <th>mm</th> <th>mm</th> <th></th> <th>$\rightarrow \leftarrow$</th> </tr> </thead> <tbody> <tr> <td>8</td> <td>1.25</td> <td>90</td> <td>20.0</td> <td>6.0</td> <td>4.9</td> <td>3</td> <td>6.80</td> </tr> <tr> <td>10</td> <td>1.50</td> <td>100</td> <td>22.0</td> <td>7.0</td> <td>5.5</td> <td>3</td> <td>8.50</td> </tr> <tr> <td>12</td> <td>1.75</td> <td>110</td> <td>24.0</td> <td>9.0</td> <td>7.0</td> <td>3</td> <td>10.30</td> </tr> <tr> <td>16</td> <td>2.00</td> <td>110</td> <td>30.0</td> <td>12.0</td> <td>9.0</td> <td>3</td> <td>14.00</td> </tr> </tbody> </table>	$\varnothing d_1$	P	l_1	l_2	d_2	α		$\pm 6H$	M	mm	mm	mm	mm	mm		$\rightarrow \leftarrow$	8	1.25	90	20.0	6.0	4.9	3	6.80	10	1.50	100	22.0	7.0	5.5	3	8.50	12	1.75	110	24.0	9.0	7.0	3	10.30	16	2.00	110	30.0	12.0	9.0	3	14.00	<table border="1"> <thead> <tr> <th>ID</th> <th>6H + mm</th> <th>ID</th> <th>6H + mm</th> <th>ID</th> <th>6H + mm</th> <th>ID</th> </tr> </thead> <tbody> <tr> <td>102194</td> <td>0.028</td> <td></td> <td></td> <td>102199</td> <td>0.052</td> <td>102196</td> </tr> <tr> <td>102060</td> <td>0.032</td> <td>143726</td> <td>0.032</td> <td>102065</td> <td>0.060</td> <td>102062</td> </tr> <tr> <td>102071</td> <td>0.034</td> <td>145655</td> <td>0.034</td> <td>102076</td> <td>0.066</td> <td>102073</td> </tr> <tr> <td>135531</td> <td>0.038</td> <td>162795</td> <td>0.038</td> <td>102094</td> <td>0.072</td> <td>102091</td> </tr> </tbody> </table>	ID	6H + mm	ID	6H + mm	ID	6H + mm	ID	102194	0.028			102199	0.052	102196	102060	0.032	143726	0.032	102065	0.060	102062	102071	0.034	145655	0.034	102076	0.066	102073	135531	0.038	162795	0.038	102094	0.072	102091
$\varnothing d_1$	P	l_1	l_2	d_2	α		$\pm 6H$																																																																													
M	mm	mm	mm	mm	mm		$\rightarrow \leftarrow$																																																																													
8	1.25	90	20.0	6.0	4.9	3	6.80																																																																													
10	1.50	100	22.0	7.0	5.5	3	8.50																																																																													
12	1.75	110	24.0	9.0	7.0	3	10.30																																																																													
16	2.00	110	30.0	12.0	9.0	3	14.00																																																																													
ID	6H + mm	ID	6H + mm	ID	6H + mm	ID																																																																														
102194	0.028			102199	0.052	102196																																																																														
102060	0.032	143726	0.032	102065	0.060	102062																																																																														
102071	0.034	145655	0.034	102076	0.066	102073																																																																														
135531	0.038	162795	0.038	102094	0.072	102091																																																																														

									N320-4	N321-4	N330-4	N330V-4	
													
N320-4													
N321-4													
N330-4													
N330V-4		V											
													
													
Ø d ₁ M	P mm	l ₁ mm	l ₂ mm	l ₃ mm	d ₂ mm	a mm		6H → ←	ID	ID	ID	ID	
* 1	0.25	40	5.5		2.5	2.1	2	0.75			101558		
* 1.1	0.25	40	5.5		2.5	2.1	2	0.85			* 101559		
* 1.2	0.25	40	5.5		2.5	2.1	2	0.95			101560		
* 1.4	0.30	40	7.0		2.5	2.1	2	1.10			101561		
* 1.6	0.35	40	8.0		2.5	2.1	2	1.25			101562	151246	
* 1.7	0.35	40	8.0		2.5	2.1	2	1.35			101563		
* 1.8	0.35	40	8.0		2.5	2.1	2	1.45			* 101564		
* 2	0.40	45	8.0		2.8	2.1	2	1.60		101552	105125	101572	
* 2.2	0.45	45	9.0		2.8	2.1	2	1.75			105126		
2.3	0.40	45	9.0		2.8	2.1	2	1.90			105127		
2.5	0.45	50	10.0		2.8	2.1	*3	2.05		101553	101565	101573	
2.6	0.45	50	10.0		2.8	2.1	*3	2.15		* 101554	101566		
3	0.50	56	12.0	18	3.5	2.7	*3	2.50		101555	101567	101574	
3.5	0.60	56	13.0	20	4.0	3.0	*3	2.90			101568	* 110953	
4	0.70	63	14.0	21	4.5	3.4	3	3.30		101557	101569	101576	
5	0.80	70	15.0	25	6.0	4.9	3	4.20	* 111525		101570	101577	
6	1.00	80	17.0	30	6.0	4.9	3	5.00	* 111526		101571	101578	
<p>* N321-3 / N330-3 / N330V-3  * N330-3 =  2 * N330V-3 =  2</p>									<p>≤ M1.5 </p>				







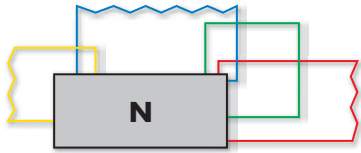

								N420-4	N421-4	N430-4	N430V-4
											
N420-4											
N421-4											
N430-4											
N430V-4											
											
											
$\varnothing d_1$ M	P mm	l_1 mm	l_2 mm	d_2 mm	α mm		$6H$ $\rightarrow \leftarrow$	ID	ID	ID	ID
4	0.70	63	14.0	2.8	2.1	3	3.30		102293		
5	0.80	70	15.0	3.5	2.7	3	4.20		102294		
6	1.00	80	17.0	4.5	3.4	3	5.00		102295		
8	1.25	90	20.0	6.0	4.9	3	6.80	102197	102296	102301	102306
10	1.50	100	22.0	7.0	5.5	3	8.50	102063	102286	102297	102302
12	1.75	110	24.0	9.0	7.0	3	10.20	102074	102287	102298	102303
14	2.00	110	28.0	11.0	9.0	3	12.00		102288		
16	2.00	110	30.0	12.0	9.0	3	14.00	102092	102289		
18	2.50	125	33.0	14.0	11.0	3	15.50		* 102290		
20	2.50	140	36.0	16.0	12.0	3	17.50	102102	102291		
24	3.00	160	39.0	18.0	14.5	4	21.00		102292		

									N350-3	N350V-3						
									 							
N350-3																
N350V-3																
									 							
									 							
									 							
									 							
Ø d ₁ M	P mm	l ₁ mm	l ₂ mm	l ₃ mm	d ₂ mm	a mm			ID	ID						
2	0.40	45	8.0		2.8	2.1	2	1.60	101580	101593						
2.3	0.40	45	9.0		2.8	2.1	2	1.90	101581							
2.5	0.45	50	10.0		2.8	2.1	2	2.05	101582	101594						
2.6	0.45	50	10.0		2.8	2.1	2	2.15	101583							
3	0.50	56	12.0	18	3.5	2.7	2	2.50	101584	101595						
3.5	0.60	56	13.0	20	4.0	3.0	2	2.90	101585							
4	0.70	63	14.0	21	4.5	3.4	2	3.30	101587	101596						
5	0.80	70	15.0	25	6.0	4.9	3	4.20	101589	101597						
6	1.00	80	17.0	30	6.0	4.9	3	5.00	101591	101598						
8	1.25	90	20.0	35	8.0	6.2	3	6.80	101592	146810						
10	1.50	100	22.0	39	10.0	8.0	3	8.50	101579	147217						

									N450-3	N450V-3		
									N450-3  			
N450V-3   												
												
												
$\varnothing d_1$ M	P mm	l ₁ mm	l ₂ mm	d ₂ mm	a mm			ID	ID			
8	1.25	90	20.0	6.0	4.9	3	6.80	102327	102334			
10	1.50	100	22.0	7.0	5.5	3	8.50	102314	102329			
12	1.75	110	24.0	9.0	7.0	3	10.20	102317	102330			
14	2.00	110	28.0	11.0	9.0	3	12.00	102319	145487			
16	2.00	110	30.0	12.0	9.0	3	14.00	102321	102331			
20	2.50	140	36.0	16.0	12.0	4	17.50	102324	102332			
24	3.00	160	39.0	18.0	14.5	4	21.00	102325	102333			

									N360-3	N360V-3	N360TN-3	N360TC-3
												
N360-3												
N360V-3	 V											
N360TN-3	 TiN											
N360TC-3	 TiCN											
												
									ISO 2 6H	ISO 2 6H	ISO 2 6H	ISO 2 6H
Ø d ₁ M	P mm	l ₁ mm	l ₂ mm	l ₃ mm	d ₂ mm	a mm			ID	ID	ID	ID
2	0.40	45	7.0		2.8	2.1	2	1.60	101618	101708	101697	
2.2	0.45	45	8.0		2.8	2.1	2	1.75	101619			
2.3	0.40	45	8.0		2.8	2.1	2	1.90	101620			
2.5	0.45	50	9.0		2.8	2.1	2	2.05	101622	101709	101698	101689
2.6	0.45	50	9.0		2.8	2.1	2	2.15	101623	101710		
3	0.50	56	5.5	18	3.5	2.7	3	2.50	101626	101711	101699	101690
3.5	0.60	56	6.5	20	4.0	3.0	3	2.90	101630	142625		
4	0.70	63	7.5	21	4.5	3.4	3	3.30	101635	101713	101700	101691
4.5	0.75	70	9.0	25	6.0	4.9	3	3.75	101639			
5	0.80	70	9.0	25	6.0	4.9	3	4.20	101644	101715	101701	101692
6	1.00	80	11.0	30	6.0	4.9	3	5.00	101652	101717	101703	101693
7	1.00	80	11.0	30	7.0	5.5	3	6.00	101656	101718		
8	1.25	90	12.5	35	8.0	6.2	3	6.80	101663	101721	101705	101694
9	1.25	90	12.5	35	9.0	7.0	3	7.80	101668			
10	1.50	100	14.0	39	10.0	8.0	3	8.50	101612	101707	101696	101688







N460-3		
N460V-3	 V	
N460TN-3	 TiN	
N460TC-3	 TiCN	

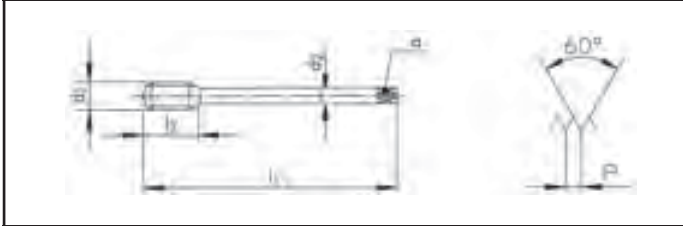

N460-3	N460V-3	N460TN-3	N460TC-3
--------	---------	----------	----------



			
---	---	---	---











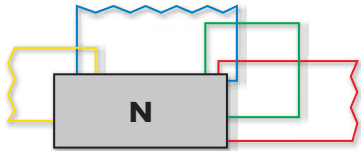

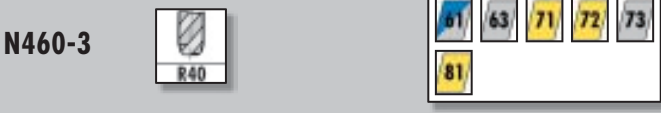



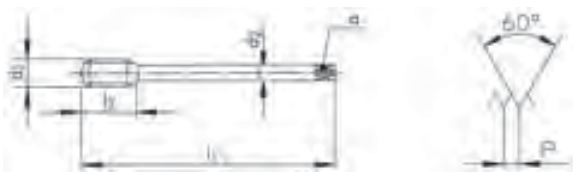
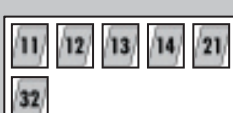

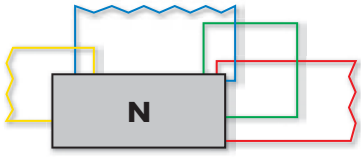

			
ISO 2 6H	ISO 2 6H	ISO 2 6H	ISO 2 6H

Ø d ₁ M	P mm	l ₁ mm	l ₂ mm	d ₂ mm	α mm			ID	ID	ID	ID
5	0.80	70	9.0	3.5	2.7	3	4.20	102410	102489	160682	
6	1.00	80	11.0	4.5	3.4	3	5.00	102411	102491	152850	
8	1.25	90	12.5	6.0	4.9	3	6.80	102412	102492	152849	
10	1.50	100	14.0	7.0	5.5	3	8.50	102351	102461	150242	
12	1.75	110	14.0	9.0	7.0	3	10.20	102359	102465	102449	102438
14	2.00	110	14.0	11.0	9.0	3	12.00	102369	102468	102451	111615
16	2.00	110	18.0	12.0	9.0	3	14.00	102376	102471	102453	102440
18	2.50	125	21.0	14.0	11.0	3	15.50	102383	102473		
20	2.50	140	24.0	16.0	12.0	3	17.50	102389	102475	102454	143280
22	2.50	140	24.0	18.0	14.5	3	19.50	102394	102477		
24	3.00	160	27.0	18.0	14.5	4	21.00	102398	102480	143119	
27	3.00	160	27.0	20.0	16.0	4	24.00		102481		
30	3.50	180	30.0	22.0	18.0	4	26.50		102482		
33	3.50	180	33.0	25.0	20.0	4	29.50		102483		
36	4.00	200	36.0	28.0	22.0	4	32.00		102484		
39	4.00	200	40.0	32.0	24.0	4	35.00		102485		
42	4.50	200	40.0	32.0	24.0	4	37.50		102486		
45	4.50	220	44.0	36.0	29.0	4	40.50		102487		
48	5.00	250	48.0	36.0	29.0	4	43.00		102488		
52	5.00	250	52.0	40.0	32.0	4	47.00		110228		
56	5.50	280	56.0	45.0	35.0	5	50.50		102490		











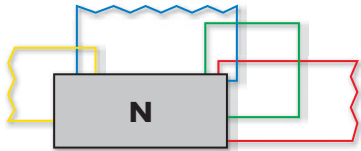











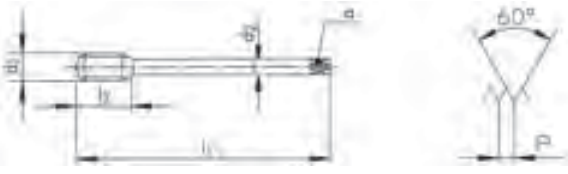

									N360-3 LH	N360V-3 LH	N360-3	N360V-3
<p>N360-3 LH LH </p> <p>N360V-3 LH V LH </p> <p>N360-3 </p> <p>N360V-3 V </p>									<p>NEW</p>			
Ø d ₁ M	P mm	l ₁ mm	l ₂ mm	l ₃ mm	d ₂ mm	a mm			ID	ID	ID ^{6H} + mm	ID ^{6H} + mm
2	0.40	45	7.0		2.8	2.1	2	1.60			101617 0.019	
2.5	0.45	50	9.0		2.8	2.1	2	2.05			101621 0.020	143294 0.020
3	0.50	56	5.5	18	3.5	2.7	3	2.50	101627	146811	101625 0.020	104816 0.020
3.5	0.60	56	6.5	20	4.0	3.0	3	2.95			101629 0.021	125829 0.021
4	0.70	63	7.5	21	4.5	3.4	3	3.30	101637	162540	101634 0.022	104817 0.022
5	0.80	70	9.0	25	6.0	4.9	3	4.20	101646	144003	101643 0.024	104818 0.024
6	1.00	80	11.0	30	6.0	4.9	3	5.00	101654	144004	101669 0.026	104819 0.026
8	1.25	90	12.5	35	8.0	6.2	3	6.80	101666	143925	101662 0.028	104820 0.028
10	1.50	100	14.0	39	10.0	8.0	3	8.50	101615	143587	101611 0.032	104821 0.032









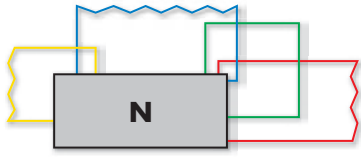

									N460-3 LH	N460V-3 LH	N460-3	N460V-3	
													
									NEW				
													
													
													
$\varnothing d_1$ M	P mm	l_1 mm	l_2 mm	d_2 mm	α mm		$\rightarrow \leftarrow$ 6H	ID	ID	ID	6H + mm	ID	6H + mm
12	1.75	110	14.0	9.0	7.0	3	10.20	102362	146354	102358	0.034	143602	0.034
14	2.00	110	14.0	11.0	9.0	3	12.00			102368	0.038	144712	0.038
16	2.00	110	18.0	12.0	9.0	3	14.00	102378	143439	102375	0.038	150197	0.038
20	2.50	140	24.0	16.0	12.0	3	17.50	102390	146564	102388	0.042	145420	0.042

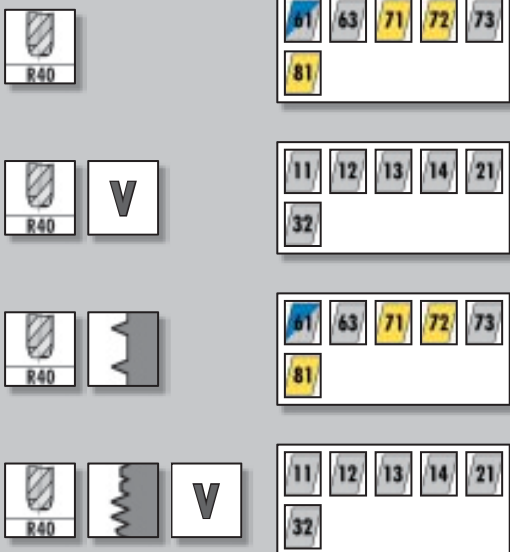
									N360-3	N360-3	N360V-3	N360-3		
									<p>N360-3</p>  					
<p>N360V-3</p>   														
														
									ISO 1 4H	7G	7G	6H +0.1mm		
Ø d ₁ M	P mm	l ₁ mm	l ₂ mm	l ₃ mm	d ₂ mm	a mm			ID	ID	6H + mm	ID	6H + mm	ID
3	0.50	56	5.5	18	3.5	2.7	3	2.50	101624	101628	0.036	144311	0.036	
4	0.70	63	7.5	21	4.5	3.4	3	3.30	101633	101638	0.041	144192	0.041	101636
5	0.80	70	9.0	25	6.0	4.9	3	4.20	101642	101647	0.044	143208	0.044	101645
6	1.00	80	11.0	30	6.0	4.9	3	5.00	101651	101655	0.050	146709	0.050	101653
8	1.25	90	12.5	35	8.0	6.2	3	△ 6.80	101661	101667	0.052	146267	0.052	101664
10	1.50	100	14.0	39	10.0	8.0	3	8.50	101610	101616	0.060	142547	0.060	101613

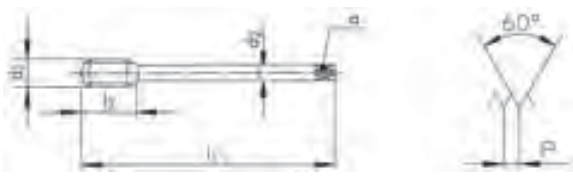
△ ISO 1
4H =  = 6.70







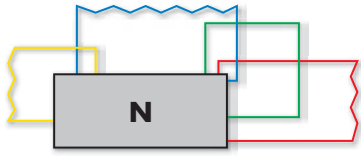

									N460-3	N460V-3	N460-3																																													
									N460-3  																																															
N460V-3   																																																								
																																																								
																																																								
<table border="1"> <thead> <tr> <th>$\varnothing d_1$</th> <th>P</th> <th>l_1</th> <th>l_2</th> <th>d_2</th> <th>α</th> <th></th> <th>$\pm 6H$</th> <th>ID</th> <th>$6H$</th> <th>ID</th> <th>$6H$</th> <th>ID</th> </tr> <tr> <th>M</th> <th>mm</th> <th>mm</th> <th>mm</th> <th>mm</th> <th>mm</th> <th></th> <th>$\rightarrow \leftarrow$</th> <th></th> <th>+ mm</th> <th></th> <th>+ mm</th> <th></th> </tr> </thead> <tbody> <tr> <td>12</td> <td>1.75</td> <td>110</td> <td>14.0</td> <td>9.0</td> <td>7.0</td> <td>3</td> <td>10.20</td> <td>102363</td> <td>0.066</td> <td>142532</td> <td>0.066</td> <td>102360</td> </tr> <tr> <td>16</td> <td>2.00</td> <td>110</td> <td>18.0</td> <td>12.0</td> <td>9.0</td> <td>3</td> <td>14.00</td> <td>102379</td> <td>0.072</td> <td>144956</td> <td>0.072</td> <td>102377</td> </tr> </tbody> </table>	$\varnothing d_1$	P	l_1	l_2	d_2	α		$\pm 6H$	ID	$6H$	ID	$6H$	ID	M	mm	mm	mm	mm	mm		$\rightarrow \leftarrow$		+ mm		+ mm		12	1.75	110	14.0	9.0	7.0	3	10.20	102363	0.066	142532	0.066	102360	16	2.00	110	18.0	12.0	9.0	3	14.00	102379	0.072	144956	0.072	102377				
$\varnothing d_1$	P	l_1	l_2	d_2	α		$\pm 6H$	ID	$6H$	ID	$6H$	ID																																												
M	mm	mm	mm	mm	mm		$\rightarrow \leftarrow$		+ mm		+ mm																																													
12	1.75	110	14.0	9.0	7.0	3	10.20	102363	0.066	142532	0.066	102360																																												
16	2.00	110	18.0	12.0	9.0	3	14.00	102379	0.072	144956	0.072	102377																																												

										N360-5	N360V-5	N361-3	N362V-3
N360-5													
N360V-5													
N361-3													
N362V-3													
Ø d ₁ M	P mm	l ₁ mm	l ₂ mm	l ₃ mm	d ₂ mm	a mm				ID	ID	ID	ID
2	0.40	45	7.0		2.8	2.1	2	1.60		158079	150058		
3	0.50	56	5.5	18	3.5	2.7	3	2.50		104809	142646	101735	
4	0.70	63	7.5	21	4.5	3.4	3	3.30		104810	142647	101736	101741
5	0.80	70	9.0	25	6.0	4.9	3	4.20		104811	142648	101737	101742
6	1.00	80	11.0	30	6.0	4.9	3	5.00		104812	142649	101738	101743
8	1.25	90	12.5	35	8.0	6.2	3	6.80		104813	142650	101739	101744
10	1.50	100	14.0	39	10.0	8.0	3	8.50		104814	124899	101734	101740

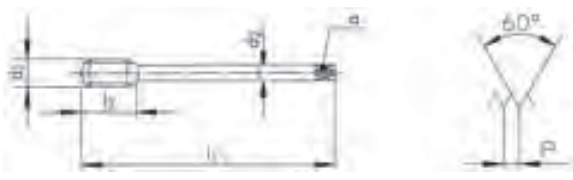
								N460-5	N460V-5	N461-3	N462V-3
											
											
											
											
$\varnothing d_1$ M	P mm	l_1 mm	l_2 mm	d_2 mm	a mm			ID	ID	ID	ID
12	1.75	110	14.0	9.0	7.0	3	10.20	104815	142651	102506	102512
14	2.00	110	14.0	11.0	9.0	3	12.00			102507	102513
16	2.00	110	18.0	12.0	9.0	3	14.00			102508	102514
18	2.50	125	21.0	14.0	11.0	3	15.50			* 111614	102515
20	2.50	140	24.0	16.0	12.0	3	17.50			* 102510	102516
22	2.50	140	24.0	18.0	14.5	3	19.50				158295
24	3.00	160	27.0	18.0	14.5	4	21.00			* 102511	102517
27	3.00	160	27.0	20.0	16.0	4	24.00				159244
30	3.50	180	30.0	22.0	18.0	4	26.50				143090











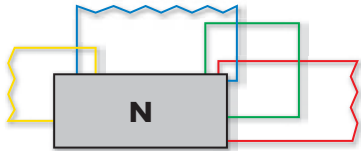



										N520-4	N520V-4	N520TN-4		
N520-4			61	63	71	72	73							
			81											
N520V-4		V	11	12	13	14	21							
			32											
N520TN-4		TiN	11	12	13	14	21							
			31	32	73	74								
										ISO 2 6H	ISO 2 6H	ISO 2 6H		
Ø d ₁	P	l ₁	l ₂	l ₃	d ₂	a				ID	ID	ID		
M	mm	mm	mm	mm	mm	mm			↔					
2.5	0.45	100	10.0		2.8	2.1	3		2.05	102594				
3	0.50	112	12.0	18	3.5	2.7	3		2.50	102595	143399	162790		
4	0.70	112	14.0	21	4.5	3.4	3		3.30	102596	143400	146837		
5	0.80	125	15.0	25	6.0	4.9	3		4.20	102597	142654	150113		
6	1.00	125	17.0	30	6.0	4.9	3		5.00	102598	143137	148821		

									N620-4	N620V-4	N620TN-4
									N620-4		
											
									ISO 2 6H	ISO 2 6H	ISO 2 6H
$\varnothing d_1$ M	P mm	l_1 mm	l_2 mm	d_2 mm	α mm			ID	ID	ID	
4	0.70	112	14.0	2.8	2.1	3	3.30	102619	142582		
5	0.80	125	15.0	3.5	2.7	3	4.20	102620	142657		
6	1.00	125	17.0	4.5	3.4	3	5.00	102621	142658		
8	1.25	140	20.0	6.0	4.9	3	6.80	102622	143401	146262	
10	1.50	160	22.0	7.0	5.5	3	8.50	102614	142660	146849	
12	1.75	180	24.0	9.0	7.0	3	10.20	102615	143127	146295	
14	2.00	180	28.0	11.0	9.0	3	12.00	102616	151905		
16	2.00	200	30.0	12.0	9.0	3	14.00	102617	143106	143574	
20	2.50	224	36.0	16.0	12.0	3	17.50	102618	143596		

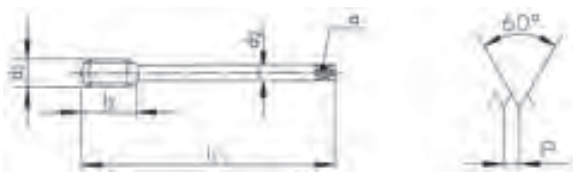

										N560-3	N560V-3	N560TN-3	
N560-3			61	63	71	72	73						
N560V-3		V	11	12	13	14	21	32					
N560TN-3		TiN	11	12	13	14	21	31	32	73	74		
										ISO 2 6H	ISO 2 6H	ISO 2 6H	
Ø d ₁ M	P mm	l ₁ mm	l ₂ mm	l ₃ mm	d ₂ mm	a mm				ID	ID	ID	
2.5	0.45	100	9.0		2.8	2.1	2	2.05		102600	102607		
3	0.50	112	5.5	18	3.5	2.7	3	2.50		102601	102608	142663	
4	0.70	112	7.5	21	4.5	3.4	3	3.30		102602	102609	142664	
5	0.80	125	9.0	25	6.0	4.9	3	4.20		102603	102610	142665	
6	1.00	125	11.0	30	6.0	4.9	3	5.00		102604	102611	142666	
8	1.25	140	12.5	35	8.0	6.2	3	6.80		102605	102612	142667	
10	1.50	160	14.0	39	10.0	8.0	3	8.50		102599	102606	142668	

									N660-3	N660V-3	N660TN-3	
									<div style="display: flex; justify-content: space-between;"> <div style="width: 30%;"> <p>N660-3</p>   </div> <div style="width: 30%;"> <p>N660V-3</p>    </div> <div style="width: 30%;"> <p>N660TN-3</p>    </div> </div>			
												
												
$\varnothing d_1$ M	P mm	l_1 mm	l_2 mm	d_2 mm	a mm			ID	ID	ID		
6	1.00	125	11.0	4.5	3.4	3	5.00	162792	115657			
8	1.25	140	12.5	6.0	4.9	3	6.80	162793	115544			
10	1.50	160	14.0	7.0	5.5	3	8.50	162794	135539			
12	1.75	180	14.0	9.0	7.0	3	10.20	102623	102626	142669		
14	2.00	180	14.0	11.0	9.0	3	12.00	162253	147500			
16	2.00	200	18.0	12.0	9.0	3	14.00	102624	102627	142670		
20	2.50	224	24.0	16.0	12.0	3	17.50	102625	102628			

									W320-4	W420-4		
$\varnothing d_1$ M	P mm	l_1 mm	l_2 mm	l_3 mm	d_2 mm	α mm			ID	ID		
* 2	0.40	45	8.0		2.8	2.1	2	1.60	104612			
2.5	0.45	50	10.0		2.8	2.1	2	2.05	104613			
2.6	0.45	50	10.0		2.8	2.1	2	2.15	104614			
3	0.50	56	12.0	18	3.5	2.7	2	2.50	104615			
3.5	0.60	56	13.0	20	4.0	3.0	2	2.90	104616			
4	0.70	63	14.0	21	4.5	3.4	2	3.30	104617			
5	0.80	70	15.0	25	6.0	4.9	2	4.20	104618			
6	1.00	80	17.0	30	6.0	4.9	2	5.00	104619			
8	1.25	90	20.0		6.0	4.9	2	6.80		104636		
10	1.50	100	22.0		7.0	5.5	2	8.50		104632		
12	1.75	110	24.0		9.0	7.0	3	10.20		104633		
16	2.00	110	30.0		12.0	9.0	3	14.00		104634		

* W320-3





										W360-3	W460-3		
										W360-3 			
W460-3 													
Ø d ₁ M	P mm	l ₁ mm	l ₂ mm	l ₃ mm	d ₂ mm	α mm				ID	ID		
2	0.40	45	7.0		2.8	2.1	2	1.60		104625			
2.5	0.45	50	9.0		2.8	2.1	2	2.05		104626			
3	0.50	56	5.5	18	3.5	2.7	2	2.50		104627			
4	0.70	63	7.5	21	4.5	3.4	2	3.30		104628			
5	0.80	70	9.0	25	6.0	4.9	2	4.20		104629			
6	1.00	80	11.0	30	6.0	4.9	2	5.00		104630			
8	1.25	90	12.5	35	8.0	6.2	2	6.80		104631			
10	1.50	100	14.0	39	10.0	8.0	2	8.50		104624			
12	1.75	110	14.0		9.0	7.0	3	10.20			104640		
16	2.00	110	18.0		12.0	9.0	3	14.00			104641		

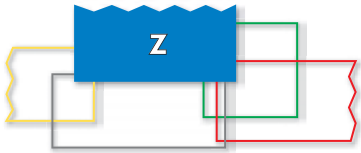

Z320V-4

Z320VS-4

Z320V-4



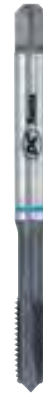

Z320VS-4



ISO 2
6H

ISO 2
6H

$\varnothing d_1$ M	P mm	l_1 mm	l_2 mm	l_3 mm	d_2 mm	α mm			ID	ID
* 1.6	0.35	40	8.0		2.5	2.1	2	1.25	142671	
* 2	0.40	45	8.0		2.8	2.1	2	1.60	111613	
2.5	0.45	50	10.0		2.8	2.1	3	2.05	111455	
2.6	0.45	50	10.0		2.8	2.1	3	2.15	142672	
3	0.50	56	12.0	18	3.5	2.7	3	2.50	104669	104830
4	0.70	63	14.0	21	4.5	3.4	3	3.30	104670	104831
5	0.80	70	15.0	25	6.0	4.9	3	4.20	104671	104832
6	1.00	80	17.0	30	6.0	4.9	3	5.00	104672	104833
8	1.25	90	20.0	35	8.0	6.2	3	6.80	104673	104834
10	1.50	100	22.0	39	10.0	8.0	3	8.50	104668	104835

* Z320V-3



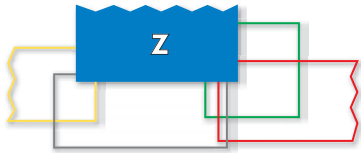

Z420V-4

Z420VS-4

Z420V-4



V

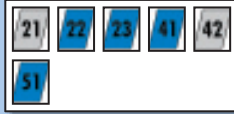



Z420VS-4

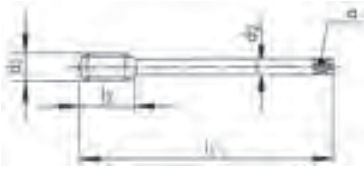

VS



$\varnothing d_1$ M	P mm	l_1 mm	l_2 mm	d_2 mm	α mm		
12	1.75	110	24.0	9.0	7.0	3	10.20
14	2.00	110	28.0	11.0	9.0	3	12.00
16	2.00	110	30.0	12.0	9.0	3	14.00
18	2.50	125	33.0	14.0	11.0	4	15.50
20	2.50	140	36.0	16.0	12.0	4	17.50
24	3.00	160	39.0	18.0	14.5	4	21.00
30	3.50	180	45.0	22.0	18.0	4	26.50

ID

ID

104723

104836

142673

143684

105068

111569











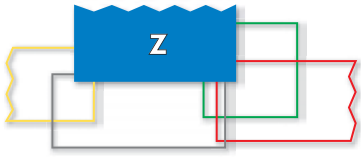

142674

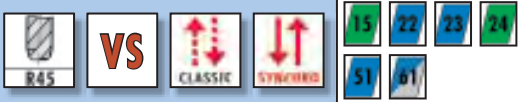
105069

111570

142675

142676

										Z362V-3	Z362V-3	Z362VS-3	Z370VS-3
Z362V-3 													
Z362VS-3 													
Z370VS-3 													
													
										ISO 2 6H		ISO 1 4H	
Ø d ₁ M	P mm	l ₁ mm	l ₂ mm	l ₃ mm	d ₂ mm	α mm			ID	ID	ID	ID	
* 2	0.40	45	7.0		2.8	2.1	2	1.60	104684				
* 2.5	0.45	50	9.0		2.8	2.1	2	2.05	104685				
* 2.6	0.45	50	9.0		2.8	2.1	2	2.15	104686				
* 3	0.50	56	5.5	18	3.5	2.7	3	2.50	104687	* 146309	111504		
3.5	0.60	56	6.5	20	4.0	3.0	3	2.90	104688				
4	0.70	63	7.5	21	4.5	3.4	3	3.30	104689	* 146311	111505		
5	0.80	70	9.0	25	6.0	4.9	3	4.20	104690	* 146313	111506		
6	1.00	80	11.0	30	6.0	4.9	3	5.00	104691	* 146315	111507		
8	1.25	90	12.5	35	8.0	6.2	3	6.80	104692	* 146317	111508		
10	1.50	100	14.0	39	10.0	8.0	3	8.50	104683	* 146301	111509		
* Z360V-3 / Z360VS-3													
Ø d ₁ M	P mm	l ₁ mm	l ₂ mm	l ₃ mm	d ₂ h ₆ mm	α mm			ID				
3	0.50	56	5.5	18	3.5(h9)	2.7	3	2.50	162776				
4	0.70	63	7.5	21	4.5(h9)	3.4	3	3.30	162777				
5	0.80	70	9.0	25	6.0	4.9	3	4.20	162778				
6	1.00	80	11.0	30	6.0	4.9	3	5.00	162779				
8	1.25	90	12.5	35	8.0	6.2	3	6.80	162780				
10	1.50	100	14.0	39	10.0	8.0	3	8.50	162781				

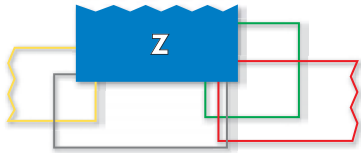

Z462V-3 Z462V-3 Z462VS-3 Z470VS-3



NEW

Z462V-3



Z462VS-3



Z470VS-3



PM



ISO 2 6H ISO 1 4H 6HX 6HX

∅ d ₁ M	P mm	l ₁ mm	l ₂ mm	d ₂ mm	a mm		
12	1.75	110	14.0	9.0	7.0	*3	10.20
14	2.00	110	14.0	11.0	9.0	*3	12.00
16	2.00	110	18.0	12.0	9.0	*3	14.00
18	2.50	125	21.0	14.0	11.0	3	15.50
20	2.50	140	24.0	16.0	12.0	*3	17.50
22	2.50	140	24.0	18.0	14.5	3	19.50
24	3.00	160	27.0	18.0	14.5	4	21.00
27	3.00	160	27.0	20.0	16.0	4	24.00
30	3.50	180	30.0	22.0	18.0	4	26.50
36	4.00	200	36.0	28.0	22.0	4	32.00
42	4.50	200	40.0	32.0	24.0	4	37.50

ID	ID	ID
104742	* 146305	111510
104743		148169
104744		111511
104745		
104746		111512
104752		
104747		111620
104748		
104749		
104750		
104751		

* Z462VS-3 = 4

∅ d ₁ M	P mm	l ₁ mm	l ₂ mm	d ₂ h ₆ mm	a mm		
12	1.75	110	14.0	*10.0	*8.0	4	10.20
14	2.00	110	14.0	*12.0	*9.0	4	12.00
16	2.00	110	18.0	12.0	9.0	4	14.00
20	2.50	140	24.0	16.0	12.0	4	17.50
24	3.00	160	27.0	16.0	12.0	4	21.00

ID
162782
162783
162784
162785
162786

* Norme DC / * DC Norm / * Norma DC

									H320-4	H320TC-4		
H320-4												
H320TC-4	TiCN											
$\varnothing d_1$ M	P mm	l_1 mm	l_2 mm	l_3 mm	d_2 mm	α mm			ID	ID		
2	0.40	45	8.0		2.8	2.1	2	1.60	101206			
2.2	0.45	45	9.0		2.8	2.1	2	1.75	111801			
2.5	0.45	50	10.0		2.8	2.1	3	2.05	101207			
3	0.50	56	12.0	18	3.5	2.7	3	2.50	101209	111836		
3.5	0.60	56	13.0	20	4.0	3.0	3	2.90	101210			
4	0.70	63	14.0	21	4.5	3.4	3	3.30	101211	111502		
4.5	0.75	70	15.0	25	6.0	4.9	3	3.75	101212			
5	0.80	70	15.0	25	6.0	4.9	3	4.20	101213	111458		
6	1.00	80	17.0	30	6.0	4.9	3	5.00	101215	111456		
8	1.25	90	20.0	35	8.0	6.2	3	6.80	101218	111453		
10	1.50	100	22.0	39	10.0	8.0	3	8.50	101205	110911		

									H420-4	H420TC-4		
H420-4												
H420TC-4		TiCN										
Ø d ₁ M	P mm	l ₁ mm	l ₂ mm	d ₂ mm	α mm				ID	ID		
12	1.75	110	24.0	9.0	7.0	4	→	10.20	101275	110912		
14	2.00	110	28.0	11.0	9.0	4	→	12.00	101277			
16	2.00	110	30.0	12.0	9.0	4	→	14.00	101279	111612		
18	2.50	125	33.0	14.0	11.0	4	→	15.50	101281			
20	2.50	140	36.0	16.0	12.0	4	→	17.50	101284			
24	3.00	160	39.0	18.0	14.5	4	→	21.00	101286			
27	3.00	160	42.0	20.0	16.0	4	→	24.00	101287			
30	3.50	180	45.0	22.0	18.0	4	→	26.50	101288			
36	4.00	200	51.0	28.0	22.0	4	→	32.00	101289			

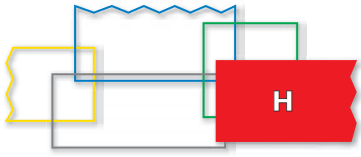

H350-3	H350-3	H350TC-3	
--------	--------	----------	--



H350-3







H350TC-3

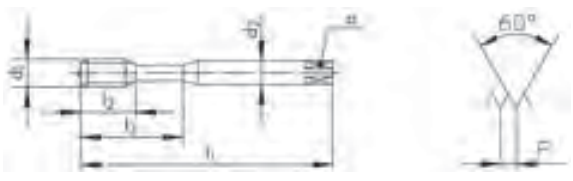

TiCN



		
ISO 2 6H	ISO 3 6G	ISO 2 6H

$\varnothing d_1$ M	P mm	l_1 mm	l_2 mm	l_3 mm	d_2 mm	α mm		$6H$ $\rightarrow \leftarrow$	ID	ID $6H$ + mm	ID
2	0.40	45	7.0		2.8	2.1	2	1.60	101238		
2.5	0.45	50	9.0		2.8	2.1	3	2.05	101239		144957
3	0.50	56	5.5	18	3.5	2.7	3	2.50	101242	101241 0.020	111835
3.5	0.60	56	6.5	20	4.0	3.0	3	2.90	101243		
4	0.70	63	7.5	21	4.5	3.4	3	3.30	101245	101244 0.022	111607
4.5	0.75	70	9.0	25	6.0	4.9	3	3.75	101246		
5	0.80	70	9.0	25	6.0	4.9	3	4.20	101248	101247 0.024	111610
6	1.00	80	11.0	30	6.0	4.9	3	5.00	101251	101250 0.026	111500
8	1.25	90	12.5	35	8.0	6.2	3	6.80	101255	101254 0.028	110963
10	1.50	100	14.0	39	10.0	8.0	3	8.50	101237	101236 0.032	111454

									H450-3	H450-3	H450TC-3	
H450-3 												
H450TC-3 												
Ø d ₁ M	P mm	l ₁ mm	l ₂ mm	d ₂ mm	α mm			6H → ←	ID	ID ^{6H} + mm	ID	
12	1.75	110	14.0	9.0	7.0	4		10.20	101305	101304 0.034	111501	
14	2.00	110	14.0	11.0	9.0	4		12.00	101307			
16	2.00	110	18.0	12.0	9.0	4		14.00	101309		111605	
18	2.50	125	21.0	14.0	11.0	4		15.50	101311			
20	2.50	140	24.0	16.0	12.0	4		17.50	101313			
22	2.50	140	24.0	18.0	14.5	4		19.50	101315			
24	3.00	160	27.0	18.0	14.5	4		21.00	101318			
27	3.00	160	27.0	20.0	16.0	4		24.00	101320			
30	3.50	180	30.0	22.0	18.0	4		26.50	101323			
36	4.00	200	36.0	28.0	22.0	4		32.00	101324			
42	4.50	200	40.0	32.0	24.0	4		37.50	101325			

										S320VS-4	S420VS-4	S360VS-3	S460VS-3	
S320VS-4		VS	13	15	24	52								
S420VS-4		VS	13	15	24	52								
S360VS-3		VS	13	15	24	52								
S460VS-3		VS	13	15	24	52								
										6HX	6HX	6HX	6HX	
$\varnothing d_1$ M	P mm	l_1 mm	l_2 mm	l_3 mm	d_2 mm	α mm				ID	ID			
3	0.50	56	12.0	18	3.5	2.7	3	2.50		111596				
4	0.70	63	14.0	21	4.5	3.4	3	3.30		111597				
5	0.80	70	15.0	25	6.0	4.9	3	4.20		111598				
6	1.00	80	17.0	30	6.0	4.9	3	5.00		111599				
8	1.25	90	20.0	35	8.0	6.2	3	6.80		111600				
10	1.50	100	22.0	39	10.0	8.0	3	8.50		111601				
12	1.75	110	24.0		9.0	7.0	4	10.20			111602			
14	2.00	110	30.0		11.0	9.0	4	12.50			162537			
16	2.00	110	30.0		12.0	9.0	4	14.00			111603			
20	2.50	140	36.0		16.0	12.0	4	17.50			111604			
$\varnothing d_1$ M	P mm	l_1 mm	l_2 mm	l_3 mm	d_2 mm	α mm				ID	ID			
3	0.50	56	5.5	18	3.5	2.7	3	2.50			111513			
4	0.70	63	7.5	21	4.5	3.4	3	3.30			111514			
5	0.80	70	9.0	25	6.0	4.9	3	4.20			111515			
6	1.00	80	11.0	30	6.0	4.9	3	5.00			111516			
8	1.25	90	12.5	35	8.0	6.2	3	6.80			111517			
10	1.50	100	14.0	39	10.0	8.0	3	8.50			111518			
12	1.75	110	14.0		9.0	7.0	4	10.20				111519		
14	2.00	110	14.0		11.0	9.0	4	12.00				148171		
16	2.00	110	18.0		12.0	9.0	4	14.00				111520		
20	2.50	140	24.0		16.0	12.0	4	17.50				111521		
24	3.00	160	27.0		18.0	14.5	4	21.00				111606		

AERO

SA390-3

SA390-3

SA390-3



$\varnothing d_1$ M	P mm	l_1 mm	l_2 mm	d_2 mm	a mm		
4	0.70	63	14.0	4.5	3.4	3	3.30
5	0.80	70	15.0	6.0	4.9	3	4.20
6	1.00	80	20.0	6.0	4.9	3	5.00
8	1.25	90	25.0	8.0	6.2	3	Δ 6.80
10	1.50	100	30.0	10.0	8.0	3	8.50
12	1.75	110	35.0	12.0	9.0	4	10.20
14	2.00	110	40.0	16.0	12.0	4	12.00
16	2.00	110	40.0	16.0	12.0	4	14.00

ID

ID

149673	149674
149693	149694
149707	149708
149736	149737
149754	149755
	149775
	149792
	149816

Δ **4HX** = = 6.70

AERO

										SA320-4	SA350-3	TL320VS-4	TL351VS-3																																																																																																																		
<div style="display: flex; justify-content: space-between;"> <div style="width: 45%;"> <p>SA320-4 52 53</p> <p>SA350-3 52 53</p> <p>TL320VS-4 VS 41 42</p> <p>TL351VS-3 VS 41 42</p> </div> <div style="width: 50%; text-align: center;"> </div> </div>																																																																																																																															
										<div style="display: flex; justify-content: space-around;"> <div style="border: 1px solid black; padding: 5px;">4HX</div> <div style="border: 1px solid black; padding: 5px;">4HX</div> <div style="border: 1px solid black; padding: 5px;">4HX</div> <div style="border: 1px solid black; padding: 5px;">4HX</div> </div>																																																																																																																					
<table border="1" style="width: 100%; border-collapse: collapse;"> <thead> <tr> <th>$\varnothing d_1$</th> <th>P</th> <th>l_1</th> <th>l_2</th> <th>l_3</th> <th>d_2</th> <th>α</th> <th></th> <th></th> <th></th> </tr> <tr> <th>M</th> <th>mm</th> <th>mm</th> <th>mm</th> <th>mm</th> <th>mm</th> <th>mm</th> <th></th> <th></th> <th></th> </tr> </thead> <tbody> <tr><td>3</td><td>0.50</td><td>56</td><td>12.0</td><td></td><td>3.5</td><td>2.7</td><td>3</td><td>2.50</td><td>ID</td></tr> <tr><td>4</td><td>0.70</td><td>63</td><td>14.0</td><td></td><td>4.5</td><td>3.4</td><td>3</td><td>3.30</td><td>ID</td></tr> <tr><td>5</td><td>0.80</td><td>70</td><td>15.0</td><td></td><td>6.0</td><td>4.9</td><td>3</td><td>4.20</td><td>ID</td></tr> <tr><td>6</td><td>1.00</td><td>80</td><td>15.0</td><td>23</td><td>6.0</td><td>4.9</td><td>3</td><td>5.00</td><td>ID</td></tr> <tr><td>8</td><td>1.25</td><td>90</td><td>18.0</td><td>29</td><td>8.0</td><td>6.2</td><td>3</td><td>6.70</td><td>ID</td></tr> <tr><td>10</td><td>1.50</td><td>100</td><td>20.0</td><td>33</td><td>10.0</td><td>8.0</td><td>3</td><td>8.50</td><td>ID</td></tr> </tbody> </table>										$\varnothing d_1$	P	l_1	l_2	l_3	d_2	α				M	mm	mm	mm	mm	mm	mm				3	0.50	56	12.0		3.5	2.7	3	2.50	ID	4	0.70	63	14.0		4.5	3.4	3	3.30	ID	5	0.80	70	15.0		6.0	4.9	3	4.20	ID	6	1.00	80	15.0	23	6.0	4.9	3	5.00	ID	8	1.25	90	18.0	29	8.0	6.2	3	6.70	ID	10	1.50	100	20.0	33	10.0	8.0	3	8.50	ID	<table border="1" style="width: 100%; border-collapse: collapse;"> <thead> <tr> <th>ID</th> <th>ID</th> <th>ID</th> <th>ID</th> </tr> </thead> <tbody> <tr><td>147975</td><td>147987</td><td>152006</td><td>152012</td></tr> <tr><td>147976</td><td>147988</td><td>152007</td><td>152013</td></tr> <tr><td>147977</td><td>147989</td><td>152008</td><td>152014</td></tr> <tr><td>147978</td><td>147990</td><td>152009</td><td>152015</td></tr> <tr><td>147979</td><td>147991</td><td>152010</td><td>152016</td></tr> <tr><td>147980</td><td>147992</td><td>152011</td><td>152017</td></tr> </tbody> </table>										ID	ID	ID	ID	147975	147987	152006	152012	147976	147988	152007	152013	147977	147989	152008	152014	147978	147990	152009	152015	147979	147991	152010	152016	147980	147992	152011	152017
$\varnothing d_1$	P	l_1	l_2	l_3	d_2	α																																																																																																																									
M	mm	mm	mm	mm	mm	mm																																																																																																																									
3	0.50	56	12.0		3.5	2.7	3	2.50	ID																																																																																																																						
4	0.70	63	14.0		4.5	3.4	3	3.30	ID																																																																																																																						
5	0.80	70	15.0		6.0	4.9	3	4.20	ID																																																																																																																						
6	1.00	80	15.0	23	6.0	4.9	3	5.00	ID																																																																																																																						
8	1.25	90	18.0	29	8.0	6.2	3	6.70	ID																																																																																																																						
10	1.50	100	20.0	33	10.0	8.0	3	8.50	ID																																																																																																																						
ID	ID	ID	ID																																																																																																																												
147975	147987	152006	152012																																																																																																																												
147976	147988	152007	152013																																																																																																																												
147977	147989	152008	152014																																																																																																																												
147978	147990	152009	152015																																																																																																																												
147979	147991	152010	152016																																																																																																																												
147980	147992	152011	152017																																																																																																																												
										<div style="display: flex; justify-content: space-around;"> <div style="border: 1px solid black; padding: 5px;">6HX</div> <div style="border: 1px solid black; padding: 5px;">6HX</div> <div style="border: 1px solid black; padding: 5px;">6HX</div> <div style="border: 1px solid black; padding: 5px;">6HX</div> </div>																																																																																																																					
<table border="1" style="width: 100%; border-collapse: collapse;"> <thead> <tr> <th>$\varnothing d_1$</th> <th>P</th> <th>l_1</th> <th>l_2</th> <th>l_3</th> <th>d_2</th> <th>α</th> <th></th> <th></th> <th></th> </tr> <tr> <th>M</th> <th>mm</th> <th>mm</th> <th>mm</th> <th>mm</th> <th>mm</th> <th>mm</th> <th></th> <th></th> <th></th> </tr> </thead> <tbody> <tr><td>3</td><td>0.50</td><td>56</td><td>12.0</td><td></td><td>3.5</td><td>2.7</td><td>3</td><td>2.50</td><td>ID</td></tr> <tr><td>4</td><td>0.70</td><td>63</td><td>14.0</td><td></td><td>4.5</td><td>3.4</td><td>3</td><td>3.30</td><td>ID</td></tr> <tr><td>5</td><td>0.80</td><td>70</td><td>15.0</td><td></td><td>6.0</td><td>4.9</td><td>3</td><td>4.20</td><td>ID</td></tr> <tr><td>6</td><td>1.00</td><td>80</td><td>15.0</td><td>23</td><td>6.0</td><td>4.9</td><td>3</td><td>5.00</td><td>ID</td></tr> <tr><td>8</td><td>1.25</td><td>90</td><td>18.0</td><td>29</td><td>8.0</td><td>6.2</td><td>3</td><td>6.80</td><td>ID</td></tr> <tr><td>10</td><td>1.50</td><td>100</td><td>20.0</td><td>33</td><td>10.0</td><td>8.0</td><td>3</td><td>8.50</td><td>ID</td></tr> </tbody> </table>										$\varnothing d_1$	P	l_1	l_2	l_3	d_2	α				M	mm	mm	mm	mm	mm	mm				3	0.50	56	12.0		3.5	2.7	3	2.50	ID	4	0.70	63	14.0		4.5	3.4	3	3.30	ID	5	0.80	70	15.0		6.0	4.9	3	4.20	ID	6	1.00	80	15.0	23	6.0	4.9	3	5.00	ID	8	1.25	90	18.0	29	8.0	6.2	3	6.80	ID	10	1.50	100	20.0	33	10.0	8.0	3	8.50	ID	<table border="1" style="width: 100%; border-collapse: collapse;"> <thead> <tr> <th>ID</th> <th>ID</th> <th>ID</th> <th>ID</th> </tr> </thead> <tbody> <tr><td>147981</td><td>147993</td><td>148001</td><td>148000</td></tr> <tr><td>147982</td><td>147994</td><td>148003</td><td>148002</td></tr> <tr><td>147983</td><td>147995</td><td>148007</td><td>148006</td></tr> <tr><td>147984</td><td>147996</td><td>148011</td><td>148010</td></tr> <tr><td>147985</td><td>147997</td><td>148020</td><td>148018</td></tr> <tr><td>147986</td><td>147998</td><td>148027</td><td>148025</td></tr> </tbody> </table>										ID	ID	ID	ID	147981	147993	148001	148000	147982	147994	148003	148002	147983	147995	148007	148006	147984	147996	148011	148010	147985	147997	148020	148018	147986	147998	148027	148025
$\varnothing d_1$	P	l_1	l_2	l_3	d_2	α																																																																																																																									
M	mm	mm	mm	mm	mm	mm																																																																																																																									
3	0.50	56	12.0		3.5	2.7	3	2.50	ID																																																																																																																						
4	0.70	63	14.0		4.5	3.4	3	3.30	ID																																																																																																																						
5	0.80	70	15.0		6.0	4.9	3	4.20	ID																																																																																																																						
6	1.00	80	15.0	23	6.0	4.9	3	5.00	ID																																																																																																																						
8	1.25	90	18.0	29	8.0	6.2	3	6.80	ID																																																																																																																						
10	1.50	100	20.0	33	10.0	8.0	3	8.50	ID																																																																																																																						
ID	ID	ID	ID																																																																																																																												
147981	147993	148001	148000																																																																																																																												
147982	147994	148003	148002																																																																																																																												
147983	147995	148007	148006																																																																																																																												
147984	147996	148011	148010																																																																																																																												
147985	147997	148020	148018																																																																																																																												
147986	147998	148027	148025																																																																																																																												



AERO

SA420-4

SA450-3

TL420VS-4

TL451VS-3



SA420-4



SA450-3



TL420VS-4



VS

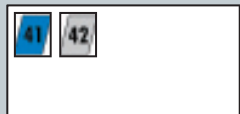

TL451VS-3



VS

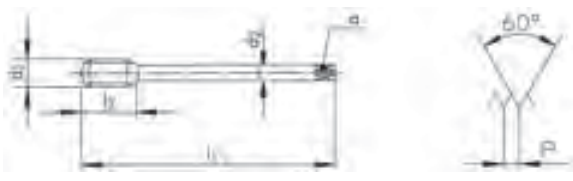
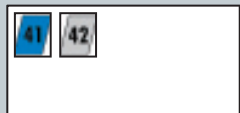

$\varnothing d_1$ M	P mm	l_1 mm	l_2 mm	d_2 mm	a mm		
12	1.75	110	24.0	9.0	7.0	4	10.20
14	2.00	110	28.0	11.0	9.0	4	12.00
16	2.00	110	30.0	12.0	9.0	4	14.00

ID	ID	ID	ID
148096	152189	152192	152195
152187	152190	152193	152196
152188	152191	152194	152197



$\varnothing d_1$ M	P mm	l_1 mm	l_2 mm	d_2 mm	a mm		
12	1.75	110	24.0	9.0	7.0	4	10.20
14	2.00	110	28.0	11.0	9.0	4	12.00
16	2.00	110	30.0	12.0	9.0	4	14.00

ID	ID	ID	ID
152198	152201	152204	148028
152199	152202	152205	152207
152200	152203	152206	148029

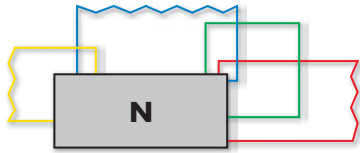

GG350NI-3 GG350TC-3 GG353TC-3 GG550NI-3



NEW

GG350NI-3



GG350TC-3



GG353TC-3



GG550NI-3

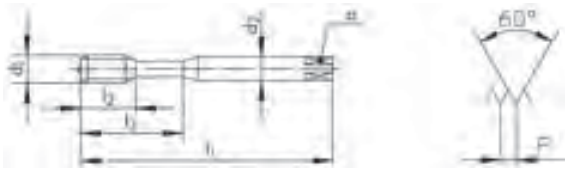
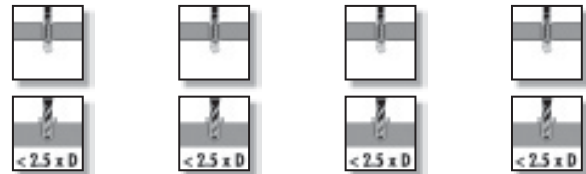
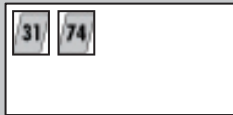

6HX 6HX 6HX 6HX

$\varnothing d_1$ M	P mm	l_1 mm	l_2 mm	l_3 mm	d_2 mm	a mm			ID	ID	ID
3	0.50	56	12.0	18	3.5	2.7	3	2.50	101172	101178	
4	0.70	63	14.0	21	4.5	3.4	3	3.30	101173	101179	
5	0.80	70	15.0	25	6.0	4.9	3	4.20	101174	101180	144947
6	1.00	80	17.0	30	6.0	4.9	3	5.00	101175	101181	147710
8	1.25	90	20.0	35	8.0	6.2	4	6.80	101076	101182	147711
10	1.50	100	22.0	39	10.0	8.0	4	8.50	101171	101177	146708

$\varnothing d_1$ M	P mm	l_1 mm	l_2 mm	l_3 mm	d_2 mm	a mm			ID
4	0.70	112	14.0	21	4.5	3.4	3	3.30	101196
5	0.80	125	15.0	25	6.0	4.9	3	4.20	101197
6	1.00	125	17.0	30	6.0	4.9	3	5.00	101198

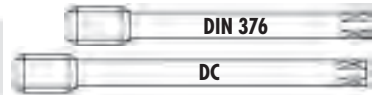

									GG450NI-3	GG450TC-3	GG453TC-3	GG650NI-3				
GG450NI-3																
GG450TC-3																
GG453TC-3																
GG650NI-3																
$\varnothing d_1$ M	P mm	l_1 mm	l_2 mm	d_2 mm	α mm				ID	ID	ID	ID				
8	1.25	90	20.0	6.0	4.9	4	6.80		101189	101194						
10	1.50	100	22.0	7.0	5.5	4	8.50		101183	101195						
12	1.75	110	24.0	9.0	7.0	4	10.20		101184	101190	146707					
14	2.00	110	28.0	11.0	9.0	4	12.00		101185	101191						
16	2.00	110	30.0	12.0	9.0	4	14.00		101186	101192	162796					
20	2.50	140	36.0	16.0	12.0	4	17.50		101187	101193						
24	3.00	160	39.0	18.0	14.5	4	21.00		101188							
$\varnothing d_1$ M	P mm	l_1 mm	l_2 mm	d_2 mm	α mm				ID							
8	1.25	140	20.0	6.0	4.9	4	6.80			101203						
10	1.50	160	22.0	7.0	5.5	4	8.50			101199						
12	1.75	180	24.0	9.0	7.0	4	10.20			101200						
16	2.00	200	30.0	12.0	9.0	4	14.00			101201						
20	2.50	224	36.0	16.0	12.0	4	17.50			101202						



Uniquement pour taraudage synchrone
Nur für Synchrobearbeitung
Only for rigid tapping
Solo per maschiatura sincrona
Solo para roscado sincronizado



RTS Rigid Tapping Synchro

RTS320VS-4



11	12	13	14
15	21	22	31
32	61	63	72
73	74		

RTS420VS-4



RTS323VS-4



11	12	13	14
15	21	22	31
32	61	63	72
73	74		

RTS423VS-4



RTS320VS-4

RTS420VS-4

RTS323VS-4

RTS423VS-4



6HX

6HX

6HX

6HX



$\varnothing d_1$ M	P mm	l_1 mm	l_2 mm	l_3 mm	d_2, h_6 mm	α mm		
* 2	0.40	45	8.0		2.8(h9)	2.1	2	1.60
* 2.5	0.45	50	10.0		2.8(h9)	2.1	3	2.05
3	0.50	56	5.5	18	3.5(h9)	2.7	3	2.50
4	0.70	63	7.5	21	4.5(h9)	3.4	3	3.30
5	0.80	70	9.0	25	6.0	4.9	3	4.20
6	1.00	80	11.0	30	6.0	4.9	3	5.00
8	1.25	90	12.5	35	8.0	6.2	3	6.80
10	1.50	100	14.0	39	10.0	8.0	3	8.50
12	1.75	110	14.0		*10.0	*8.0	3	10.20
14	2.00	110	14.0		*12.0	*9.0	3	12.50
16	2.00	110	18.0		12.0	9.0	3	14.00
20	2.50	140	24.0		16.0	12.0	4	17.50
24	3.00	160	27.0		16.0	12.0	4	21.00

ID

ID

ID

ID

143532

143534

150601

150603

150605

150606

150610

150611

150620

150621

150635

150636

151863

151864

162535

150670

150671

150679

162787

* Norme DC / * DC Norm / * Norma DC

* RTS320VS-3



sur demande
auf Anfrage
on request
su richiesta
sobre pedido



264/265



Uniquement pour taraudage synchrone
Nur für Synchrobearbeitung
Only for rigid tapping
Solo per maschiatura sincrona
Solo para roscado sincronizado



RTS

Rigid Tapping Synchro

RTS362VS-3 RTS462VS-3 RTS365VS-3 RTS465VS-3

RTS362VS-3



RTS462VS-3



RTS365VS-3



RTS465VS-3



∅ d ₁ M	P mm	l ₁ mm	l ₂ mm	l ₃ mm	d ₂ h6 mm	α mm		
* 2	0.40	45	7.0		2.8 (h9)	2.1	3	1.60
* 2.5	0.45	50	9.0		2.8 (h9)	2.1	3	2.05
3	0.50	56	5.5	18	3.5 (h9)	2.7	3	2.50
4	0.70	63	7.5	21	4.5 (h9)	3.4	3	3.30
5	0.80	70	9.0	25	6.0	4.9	3	4.20
6	1.00	80	11.0	30	6.0	4.9	3	5.00
8	1.25	90	12.5	35	8.0	6.2	3	6.80
10	1.50	100	14.0	39	10.0	8.0	3	8.50
12	1.75	110	14.0		*10.0	*8.0	3	10.20
14	2.00	110	14.0		*12.0	*9.0	3	12.00
16	2.00	110	18.0		12.0	9.0	3	14.00
20	2.50	140	24.0		16.0	12.0	4	17.50
24	3.00	160	27.0		16.0	12.0	4	21.00

ID	ID	ID	ID
143536			
143538			
150602		160477	
150604		160478	
150607		150608	
150612		150613	
150622		150623	
150637		150638	
	151865		151866
	151870		150663
	150672		150673
	150681		150682
	151873		150690

* Norme DC / * DC Norm / * Norma DC

* RTS360VS-3



sur demande
auf Anfrage
on request
su richiesta
sobre pedido



264/265



Uniquement pour taraudage synchrone
Nur für Synchroanbearbeitung
Only for rigid tapping
Solo per maschiatura sincrona
Solo para roscado sincronizado



RTS Rigid Tapping Synchro

RTS362VS-5 **VS**

RTS365VS-5 **VS**

RTS362VS-3 **VS**

RTS362VS-5 RTS365VS-5 RTS362VS-3



NEW

NEW

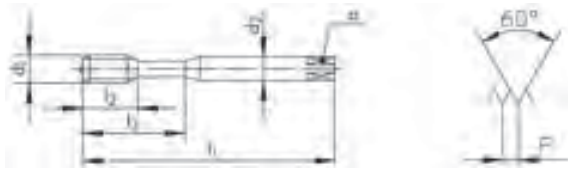

$\varnothing d_1$ M	P mm	l_1 mm	l_2 mm	l_3 mm	$d_2 h6$ mm	α mm			ID	ID
3	0.50	56	5.5	18	3.5(h9)	2.7	3	2.50	157648	
4	0.70	63	7.5	21	4.5(h9)	3.4	3	3.30	157650	
5	0.80	70	9.0	25	6.0	4.9	3	4.20	157652	162791
6	1.00	80	11.0	30	6.0	4.9	3	5.00	158074	151803
8	1.25	90	12.5	35	8.0	6.2	3	6.80	158076	157821
10	1.50	100	14.0	39	10.0	8.0	3	8.50	153286	157823

$\varnothing d_1$ M	P mm	l_1 mm	l_2 mm	l_3 mm	$d_2 h6$ mm	α mm			ID	6H + mm
3	0.50	56	5.5	18	3.5(h9)	2.7	3	2.50	162797	0.020
4	0.70	63	7.5	21	4.5(h9)	3.4	3	3.35	162798	0.022
5	0.80	70	9.0	25	6.0	4.9	3	4.25	162799	0.024
6	1.00	80	11.0	30	6.0	4.9	3	5.00	162800	0.026
8	1.25	90	12.5	35	8.0	6.2	3	6.80	162801	0.028
10	1.50	100	14.0	39	10.0	8.0	3	8.50	162802	0.032



sur demande
auf Anfrage
on request
su richiesta
sobre pedido



264/265



Uniquement pour taraudage synchrone
Nur für Synchronbearbeitung
Only for rigid tapping
Solo per maschiatura sincrona
Solo para roscado sincronizado

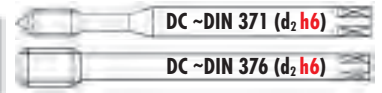

RTS

Rigid Tapping Synchro

RTS523VS-4 RTS623VS-4 RTS565VS-3 RTS665VS-3

RTS523VS-4 **VS**

11	12	13	14
15	21	22	31
32	41	63	72
73	74		

RTS623VS-4 **VS**

11	12	13	14
15	21	22	31
32	41	63	72
73	74		

RTS565VS-3 **VS**

11	12	13	14
15	21	22	31
32	41	63	72
73	74		

RTS665VS-3 **VS**

11	12	13	14
15	21	22	31
32	41	63	72
73	74		



$\varnothing d_1$ M	P mm	l_1 mm	l_2 mm	l_3 mm	$d_2 h6$ mm	α mm		
5	0.80	125	9.0	25	6.0	4.9	3	4.20
6	1.00	125	11.0	30	6.0	4.9	3	5.00
8	1.25	140	12.5	35	8.0	6.2	3	6.80
10	1.50	160	14.0	39	10.0	8.0	3	8.50
12	1.75	180	14.0		*10.0	*8.0	3	10.20
16	2.00	200	18.0		12.0	9.0	3	14.00

ID	ID
161038	
161041	
161044	
161047	
	161050
	161053

* Norme DC / * DC Norm / * Norma DC

$\varnothing d_1$ M	P mm	l_1 mm	l_2 mm	l_3 mm	$d_2 h6$ mm	α mm		
6	1.00	125	11.0	30	6.0	4.9	3	5.00
8	1.25	140	12.5	35	8.0	6.2	3	6.80
10	1.50	160	14.0	39	10.0	8.0	3	8.50
12	1.75	180	14.0		*10.0	*8.0	3	10.20
16	2.00	200	18.0		12.0	9.0	3	14.00

ID	ID
150614	
150624	
150639	
	151867
	150674

* Norme DC / * DC Norm / * Norma DC

sur demande
auf Anfrage
on request
su richiesta
sobre pedido
 $\geq \varnothing 6 \text{ mm}$

264/265

FS FORMING

FS380VS-5



VS

FS380VS-3



VS

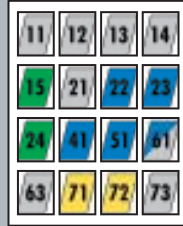

FS380VS-5

FS380VS-5

FS380VS-3

FS380VS-3



$\varnothing d_1$ M	P mm	l_1 mm	l_2 mm	d_2 mm	α mm	6HX Tol. → ←	ID	ID	ID	ID	6H + mm
1	0.25	40	3.0	2.5		0.88 +/- 0.01	157171				
1.2	0.25	40	3.6	2.5		1.08 +/- 0.01	157172				
1.4	0.30	40	4.2	2.5		1.25 +/- 0.01	157173				
1.6	0.35	40	4.8	2.5		1.45 +/- 0.02		157174			
1.8	0.35	40	5.4	2.5		1.65 +/- 0.02		157175			
2	0.40	45	8.0	2.8	2.1	1.80 +/- 0.02			157176		157180 0.019
2.5	0.45	50	10.0	2.8	2.1	2.30 +/- 0.03			157178		157181 0.020
2.6	0.45	50	10.0	2.8	2.1	2.40 +/- 0.03			157179		

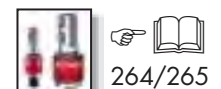

FP FORMING

FP380CN-3 FP381CN-3 FP380VS-3 FP380VS-3



FP380CN-3

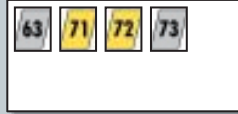

FP381CN-3



FP380VS-3

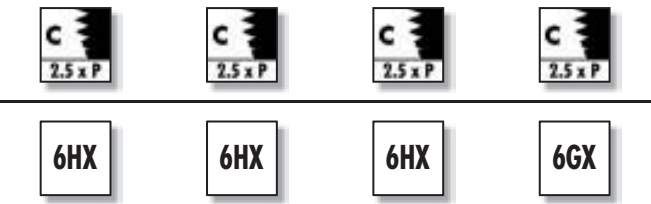
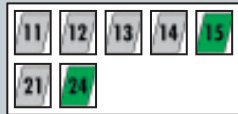

Ø d ₁ M	P mm	l ₁ mm	l ₂ mm	l ₃ mm	d ₂ mm	a mm	6HX Tol. → ←
3	0.50	56	12.0	18	3.5	2.7	2.80 +/- 0.03
3.5	0.60	56	13.0	20	4.0	3.0	3.25 +/- 0.03
4	0.70	63	14.0	21	4.5	3.4	3.70 +/- 0.03
5	0.80	70	15.0	25	6.0	4.9	4.65 +/- 0.03
6	1.00	80	17.0	30	6.0	4.9	5.55 +/- 0.05
8	1.25	90	20.0	35	8.0	6.2	7.40 +/- 0.05
10	1.50	100	22.0	39	10.0	8.0	9.30 +/- 0.05

ID	ID	ID	ID	6H + mm
151082	151092	157152	157813	0.020
151083	151093	157153	151693	0.021
151084	151094	157154	157814	0.022
151085	151095	157155	160532	0.024
151086	151096	157156	151487	0.026
151087	151097	157157	160791	0.028
151088	151098	157158	160747	0.032





FP FORMING

FP381VS-3



VS



FP481VS-3



VS

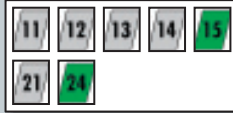

FP381VS-3

FP481VS-3

FP381VS-3

FP481VS-3



6HX

6HX

6GX

6GX

$\varnothing d_1$ M	P mm	l_1 mm	l_2 mm	l_3 mm	d_2 mm	a mm	6HX Tol. → ←	ID	ID	ID 6H + mm	ID 6H + mm
3	0.50	56	12.0	18	3.5	2.7	2.80 +/- 0.03	151055		151065 0.020	
3.5	0.60	56	13.0	20	4.0	3.0	3.25 +/- 0.03	151056		151066 0.021	
4	0.70	63	14.0	21	4.5	3.4	3.70 +/- 0.03	151057		151067 0.022	
5	0.80	70	15.0	25	6.0	4.9	4.65 +/- 0.03	151058		151068 0.024	
6	1.00	80	17.0	30	6.0	4.9	5.55 +/- 0.05	151059		151069 0.026	
8	1.25	90	20.0	35	8.0	6.2	7.40 +/- 0.05	151060		151070 0.028	
10	1.50	100	22.0	39	10.0	8.0	9.30 +/- 0.05	151061		151071 0.032	
12	1.75	110	24.0		9.0	7.0	11.20 +/- 0.05		151062		* 151072 0.034
14	2.00	110	28.0		11.0	9.0	13.10 +/- 0.05		151063		* 151073 0.038
16	2.00	110	30.0		12.0	9.0	15.10 +/- 0.05		151064		* 151074 0.038





FP FORMING

FP384VS-3

FP484VS-3

FP384VS-3



VS



FP484VS-3



VS

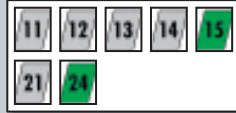

6HX

6HX

$\varnothing d_1$ M	P mm	l_1 mm	l_2 mm	l_3 mm	d_2 mm	a mm	$\rightarrow \leftarrow$	Tol.
3	0.50	56	12.0	18	3.5	2.7	2.80	+/- 0.03
4	0.70	63	14.0	21	4.5	3.4	3.70	+/- 0.03
5	0.80	70	15.0	25	6.0	4.9	4.65	+/- 0.03
6	1.00	80	17.0	30	6.0	4.9	5.55	+/- 0.05
8	1.25	90	20.0	35	8.0	6.2	7.40	+/- 0.05
10	1.50	100	22.0	39	10.0	8.0	9.30	+/- 0.05
12	1.75	110	24.0		9.0	7.0	11.20	+/- 0.05
14	2.00	110	28.0		11.0	9.0	13.10	+/- 0.05
16	2.00	110	30.0		12.0	9.0	15.10	+/- 0.05

ID

ID

161058

161059

151075

151076

151077

151078

151079

151080

151081



266/267

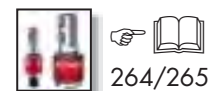

264/265



FA FORMING

FA381VS-3



VS

FA481VS-3



VS



FA381VS-3

FA481VS-3

FA381VS-3

FA481VS-3

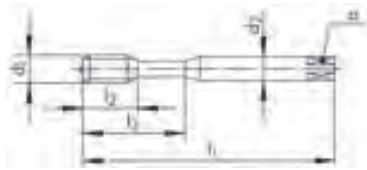

6HX

6HX

6GX

6GX

$\varnothing d_1$ M	P mm	l_1 mm	l_2 mm	l_3 mm	d_2 mm	a mm	6HX Tol. → ←	ID	ID	ID 6H + mm	ID 6H + mm
3	0.50	56	12.0	18	3.5	2.7	2.80 +/- 0.03	151045		157195 0.020	
3.5	0.60	56	13.0	20	4.0	3.0	3.25 +/- 0.03	151046		157196 0.021	
4	0.70	63	14.0	21	4.5	3.4	3.70 +/- 0.03	151047		157197 0.022	
5	0.80	70	15.0	25	6.0	4.9	4.65 +/- 0.03	151048		157198 0.024	
6	1.00	80	17.0	30	6.0	4.9	5.55 +/- 0.05	151049		157199 0.026	
8	1.25	90	20.0	35	8.0	6.2	7.40 +/- 0.05	151050		157200 0.028	
10	1.50	100	22.0	39	10.0	8.0	9.30 +/- 0.05	151051		157201 0.032	
12	1.75	110	24.0		9.0	7.0	11.20 +/- 0.05		151052		157202 0.034
14	2.00	110	28.0		11.0	9.0	13.10 +/- 0.05		151053		157203 0.038
16	2.00	110	30.0		12.0	9.0	15.10 +/- 0.05		151054		157204 0.038

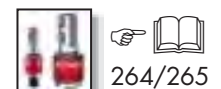



FA FORMING

FA384VS-3



FA484VS-3



FA384VS-3

FA484VS-3

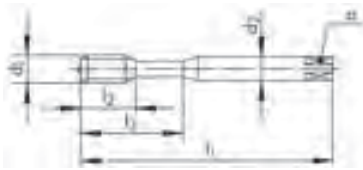

6HX

6HX

$\varnothing d_1$ M	P mm	l_1 mm	l_2 mm	l_3 mm	d_2 mm	a mm	$\rightarrow \leftarrow$	Tol.
3	0.50	56	12.0	18	3.5	2.7	2.80	+/- 0.03
4	0.70	63	14.0	21	4.5	3.4	3.70	+/- 0.03
5	0.80	70	15.0	25	6.0	4.9	4.65	+/- 0.03
6	1.00	80	17.0	30	6.0	4.9	5.55	+/- 0.05
8	1.25	90	20.0	35	8.0	6.2	7.40	+/- 0.05
10	1.50	100	22.0	39	10.0	8.0	9.30	+/- 0.05
12	1.75	110	24.0		9.0	7.0	11.20	+/- 0.05
14	2.00	110	28.0		11.0	9.0	13.10	+/- 0.05
16	2.00	110	30.0		12.0	9.0	15.10	+/- 0.05

ID

ID

161060

161062

155159

155160

155161

155162

155163

155164

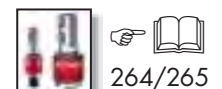

155165





										N1120-4	N1121-4	N1220-4	N1221-4	
N1120-4														
N1121-4														
N1220-4														
N1221-4														
Ø d ₁ M	P mm	l ₁ mm	l ₂ mm	l ₃ mm	d ₂ mm	α mm				ID	ID	ID	ID	
2.5	0.45	45	9.5		2.8	2.1	3							
3	0.50	48	11.0	18	3.2	2.5	3			103068	* 103135			
3.5	0.60	50	13.0	20	3.5	2.8	3			* 103071	* 103137			
4	0.70	53	13.0	21	4.0	3.2	3			103075				
4.5	0.75	53	13.0	21	4.5	3.5	3			103078				
5	0.80	58	16.0	25	5.0	4.0	3			103082				
5.5	0.90	62	17.0	26	5.6	4.5	3			* 103085				
6	1.00	66	19.0	30	6.3	5.0	3			103090				
7	1.00	66	19.0	30	7.1	5.6	3			* 103094				
8	1.25	72	22.0	35	8.0	6.3	3			103102				
10	1.50	80	24.0	39	10.0	8.0	3			103060				
11	1.50	85	22.0		8.0	6.3	3					* 103661		
12	1.75	89	24.0		9.0	7.1	3					103670	* 103773	
14	2.00	95	24.0		11.2	9.0	3					103680		
16	2.00	102	32.0		12.5	10.0	3					103690		
18	2.50	112	30.0		14.0	11.2	3					* 103700		
20	2.50	112	37.0		14.0	11.2	3					* 103707		
24	3.00	130	45.0		18.0	14.0	4					* 103719		
27	3.00	135	45.0		20.0	16.0	4					* 103728		
30	3.50	138	48.0		20.0	16.0	4					* 103737		
33	3.50	151	51.0		22.4	18.0	4					* 103739		
36	4.00	162	57.0		25.0	20.0	4					* 103740		
39	4.00	170	60.0		28.0	22.4	4					* 103741		
45	4.50	187	67.0		31.5	25.0	4					* 111335		

Наборы метчиков
Zestawy gwintowników

		D5855		
D5855	<p><i>Набор метчиков M3 – M12, в прочном металлическом ящике. Содержит: комплекты шлифованных метчиков, общие размеры по ИСО 529, по одному каждого размера.</i></p> <p>Gwintowniki od M3 – M12, w metalowym pudełku. Zawartość: zestawy gwintowników, ogólne wymiary zgodne z ISO 529.</p>			
No D5855		ID		
M3 - M12		118728		
			D5860	
D5860	<p><i>Набор метчиков M3 – M12, в прочном металлическом ящике. Содержит: комплекты шлифованных метчиков, общие размеры по ИСО 529, по одному каждого размера и гнезда для соответствующих сверл под резьбу.</i></p> <p>Gwintowniki od M3 – M12, w metalowym pudełku. Zawartość: zestawy gwintowników, ogólne wymiary zgodne z ISO 529. Obok gwintowników znajdują się wolne miejsca na odpowiednie wiertła.</p>			
No D5860		ID		
M3 - M12		118733		















































									N1110-1	N1110-2	N1110-3	N1110-S		
N1110-1														
N1110-2														
N1110-3														
N1110-S														
											ISO 2 6H		ISO 2 6H	
Ø d ₁ M	P mm	l ₁ mm	l ₂ mm	l ₃ mm	d ₂ mm	a mm			ID	ID	ID	ID		
1	0.25	40	5.5		2.5	2.1	3	0.75	102744	102844	102917	111015		
1.2	0.25	40	5.5		2.5	2.1	3	0.95	102746	102846	102919	111017		
1.4	0.30	40	7.0		2.5	2.1	3	1.10	102747	102847	102920	111018		
1.6	0.35	40	8.0		2.5	2.1	3	1.25	102749	102849	102922	111020		
1.7	0.35	40	8.0		2.5	2.1	3	1.35	102750	102850	102923	111021		
1.8	0.35	40	8.0		2.5	2.1	3	1.45	102751	102851	102924	111022		
2	0.40	45	8.0		2.8	2.1	3	1.60	102759	102854	102934	111028		
2.2	0.45	45	9.5		2.8	2.1	3	1.75	102761	102856	102937	111030		
2.5	0.45	45	9.5		2.8	2.1	3	2.05	102763	102858	102941	111032		
2.6	0.45	45	9.5		2.8	2.1	3	2.15	102765	102860	102944	111034		
3	0.50	48	11.0	18	3.2	2.5	3	2.50	102766	102861	102947	111036		
3.5	0.60	50	13.0	20	3.5	2.8	3	2.90	102769	102864	102950	111038		
4	0.70	53	13.0	21	4.0	3.2	3	3.30	102771	102866	102956	111042		
4.5	0.75	53	13.0	21	4.5	3.5	3	3.75	102775	102869	102959	111044		
5	0.80	58	16.0	25	5.0	4.0	3	4.20	102776	102870	102965	111047		
5.5	0.90	62	17.0	26	5.6	4.5	3	4.60			* 102968			
6	1.00	66	19.0	30	6.3	5.0	3	5.00	102781	102874	102973	111053		
7	1.00	66	19.0	30	7.1	5.6	3	6.00	102786	102876	102978	111055		
8	1.25	72	22.0	35	8.0	6.3	3	6.80	102788	102878	102986	111059		
9	1.25	72	22.0	36	9.0	7.1	3	7.80	102792	102880	102991	111061		
10	1.50	80	24.0	39	10.0	8.0	3	8.50	102752	102852	102931	111026		

									N1210-1	N1210-2	N1210-3	N1210-S
									ISO 2 6H		ISO 2 6H	
$\varnothing d_1$ M	P mm	l_1 mm	l_2 mm	d_2 mm	a mm				ID	ID	ID	ID
11	1.50	85	22.0	8.0	6.3	3	9.50		103302	103427	103489	111168
12	1.75	89	24.0	9.0	7.1	3	10.20		103303	103428	103499	111173
14	2.00	95	24.0	11.2	9.0	3	12.00		103310	103430	103510	111179
16	2.00	102	32.0	12.5	10.0	3	14.00		103319	103432	103522	111185
18	2.50	112	30.0	14.0	11.2	3	15.50		103324	103434	103534	111191
20	2.50	112	37.0	14.0	11.2	3	17.50		103330	103436	103543	111196
22	2.50	115	32.0	16.0	12.5	3	19.50		103337	103438	103550	125567
24	3.00	130	45.0	18.0	14.0	4	21.00		103341	103440	103557	111204
27	3.00	135	45.0	20.0	16.0	4	24.00		103347	103442	103568	111211
30	3.50	138	48.0	20.0	16.0	4	26.50		103353	103444	103579	111216
33	3.50	151	51.0	22.4	18.0	4	29.50		103357	103446	103581	111218
36	4.00	162	57.0	25.0	20.0	4	32.00		103359	103448	103583	111220
39	4.00	170	60.0	28.0	22.4	4	35.00		* 103361	* 103450	* 103585	* 111222
42	4.50	170	60.0	28.0	22.4	4	37.50		* 103362	* 103451	* 103586	* 111223

		N							
Характеристики Cechy charakterystyczne									
					V	TiN	R15	R40	
Типы отверстий Typ otworu									
			N320-3	N320-4			N350-3	N360-3	
Длинный по DIN DIN długi	DIN 371		80	80			87	88	
Короткий по ISO ISO krótki	ISO 529								
Класс точности Tolerancja	ISO 2 6H			80			87	88	
Класс точности Tolerancja	6HX								
Класс точности Tolerancja	ISO 1 4H		80						
Класс точности Nadwymiar	ISO 3 6G							88	
			N410-3	N420-3	N420-4	N420V-4	N420TN-4	N450-3	N460-3
Длинный по DIN DIN długi	DIN 374	81/85	84/85	81/85	81/83	81/82	87	89	
Короткий по ISO ISO krótki	ISO 529								
Класс точности Tolerancja	ISO 2 6H	81/85	84/85	81/85	81/83	81/82	87	89	
Класс точности Tolerancja	6HX								
Класс точности Tolerancja	ISO 1 4H								
Класс точности Nadwymiar	ISO 3 6G							89	
Класс точности Tolerancja	7H (EN 60423)		84/85						
Левая резьба LH Gwint lewy	ISO 2 6H	86		86					

N						Z		
								
								
								
								
N360V-3	N360TN-3	N1120-3 N1120-4	N1110-1	N1110-3	N1110-S	Z320V-4	Z360V-3	Z360VS-3
88	88					90	90	90
		101	101	101	101			
88	88	101		101	101	90	90	90
						90		
N460V-3	N460TN-3	N1220-4	N1210-1	N1210-3	N1210-S	Z420V-4	Z460V-3	Z460VS-3
89	89					91	91	91
		102/103	102/103	102/103	102/103			
89	89	102/103		102/103	102/103	91	91	91
								91

	H		S		SA		
Характеристики Cechy charakterystyczne							
			VS	VS			
							
Типы отверстий Typ otworu							
	H320-4	H350-3	S320VS-4	S360VS-3	SA320-4	SA350-3	SA390-3
Длинный по DIN DIN długi	DIN 371						
	92	93	94	94	96	96	95
Короткий по ISO ISO krótki							
Класс точности Tolerancja	ISO 2 6H						
	92	93					
Класс точности Tolerancja	6HX						
			94	94	96	96	95
Повышенный класс точности Tolerancja dokładna	4HX						
					96	96	
Класс точности Nadwymiar	ISO 3 6G						
	H420-4	H450-3	S420VS-4	S460VS-3	SA420-4	SA450-3	
Длинный по DIN DIN długi	DIN 374						
	92	93	94	94	97	97	
Короткий по ISO ISO krótki							
Класс точности Tolerancja	ISO 2 6H						
	92	93					
Класс точности Tolerancja	6HX						
			94	94	97	97	
Повышенный класс точности Tolerancja dokładna	4HX						
					97	97	

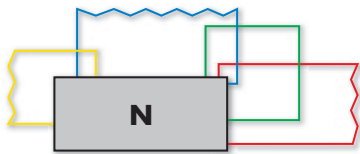

TL		RTS		FP		FA		
								
VS		VS	VS		VS	VS		
								
								
TL320VS-4	TL351VS-3	RTS320VS-4	RTS362VS-3	FP381CN-3	FP381VS-3	FA381VS-3		
96	96	98	98	99	99	100		
96	96	98	98	99	99	100		
96	96							
TL420VS-4	TL451VS-3	RTS420VS-4	RTS462VS-3	FP481CN-3	FP481VS-3	FA481VS-3		
97	97	98	98	99	99	100		
97	97	98	98	99	99	100		
97	97							



N320-4

N320-4



Ø d ₁ MF	P mm	l ₁ mm	l ₂ mm	l ₃ mm	d ₂ mm	α mm			ID
* 2	0.25	45	8.0		2.8	2.1	2	1.75	142689
* 2.3	0.25	45	9.0		2.8	2.1	2	2.05	* 142690
2.5	0.35	50	10.0		2.8	2.1	3	2.15	142691
2.6	0.35	50	10.0		2.8	2.1	3	2.25	142692
3	0.35	56	12.0	18	3.5	2.7	3	2.65	142693
3.5	0.35	56	13.0	20	4.0	3.0	3	3.15	142694

* N320-3



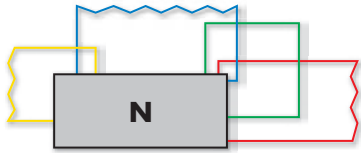

N410-3 **N420-4** **N420V-4** **N420TN-4**



N410-3



N420-4



N420V-4



V

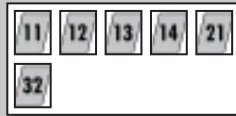



N420TN-4



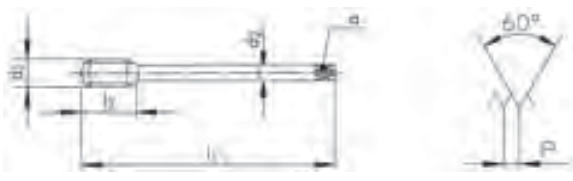





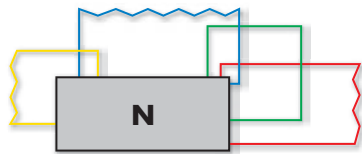

TiN











ISO 2 6H **ISO 2 6H** **ISO 2 6H** **ISO 2 6H**





∅ d ₁ MF	P mm	l ₁ mm	l ₂ mm	d ₂ mm	a mm			ID	ID	ID	ID
4	0.35	63	14.0	2.8	2.1	3	3.65		142695		
4	0.50	63	14.0	2.8	2.1	3	3.50	101923	102145	142715	
4.5	0.50	70	15.0	3.5	2.7	3	4.00		102150		
5	0.50	70	15.0	3.5	2.7	3	4.50	101941	102167	142716	
5	0.75	70	15.0	3.5	2.7	3	4.25		102168		
5.5	0.50	80	17.0	4.0	3.0	3	5.00		142696		
6	0.50	80	17.0	4.5	3.4	3	5.50	101951	102178	142717	
6	0.75	80	17.0	4.5	3.4	3	5.25	101952	102179	102281	102249
7	0.50	80	17.0	5.5	4.3	3	6.50		102187		
7	0.75	80	17.0	5.5	4.3	3	6.25	101954	102188		
8	0.50	90	20.0	6.0	4.9	3	7.50	101955	102190	142718	
8	0.75	90	20.0	6.0	4.9	3	7.25	101956	102191	102283	
8	1.00	90	20.0	6.0	4.9	3	7.00	101957	102192	102284	102250
9	0.50	90	20.0	7.0	5.5	3	8.50		142697		
9	0.75	90	20.0	7.0	5.5	3	8.25		102200		
9	1.00	90	20.0	7.0	5.5	3	8.00		102201	143935	
10	0.50	100	22.0	7.0	5.5	3	9.50		142698		
10	0.75	100	22.0	7.0	5.5	3	9.25	101863	102056		
10	1.00	100	22.0	7.0	5.5	3	9.00	101864	102057	102262	102239
10	1.25	100	22.0	7.0	5.5	3	8.80	101865	102058	142719	



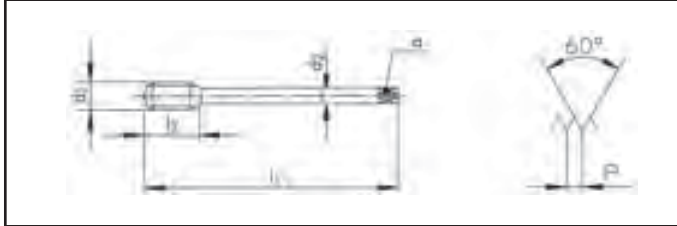

N410-3		
N420-4		
N420V-4	 V	
N420TN-4	 TiN	

N410-3	N420-4	N420V-4	N420TN-4
			
			



			
ISO 2 6H	ISO 2 6H	ISO 2 6H	ISO 2 6H

∅ d ₁ MF	P mm	l ₁ mm	l ₂ mm	d ₂ mm	a mm			ID	ID	ID	ID
11	0.50	100	19.0	8.0	6.2	3	10.50				
11	0.75	100	19.0	8.0	6.2	3	10.25				
11	1.00	100	19.0	8.0	6.2	3	10.00				
11	1.25	100	19.0	8.0	6.2	3	9.80				
12	0.50	100	14.0	9.0	7.0	3	11.50				
12	0.75	100	24.0	9.0	7.0	3	11.25				
12	1.00	100	24.0	9.0	7.0	3	11.00	101867	102067	142345	102241
12	1.25	100	24.0	9.0	7.0	3	10.80	101868	102068	142721	
12	1.50	100	24.0	9.0	7.0	3	10.50	101869	102069	102264	102242
13	1.00	100	21.0	11.0	9.0	3	12.00	158401	142704		
14	0.50	100	14.0	11.0	9.0	3	13.50		142705		
14	0.75	100	24.0	11.0	9.0	3	13.25		142706		
14	1.00	100	24.0	11.0	9.0	3	13.00	101871	102077		
14	1.25	100	24.0	11.0	9.0	3	12.80	101872	102078		
14	1.50	100	24.0	11.0	9.0	3	12.50	101873	102079	102266	102244
15	0.75	100	26.0	12.0	9.0	3	14.25		* 142707		
15	1.00	100	26.0	12.0	9.0	3	14.00	101875	102085		
15	1.50	100	26.0	12.0	9.0	3	13.50	101876	102086		
16	0.75	100	26.0	12.0	9.0	3	15.25		142708		
16	1.00	100	26.0	12.0	9.0	*3	15.00	101877	102087		
16	1.25	100	26.0	12.0	9.0	*3	14.80	101878	102088		
16	1.50	100	26.0	12.0	9.0	*3	14.50	101879	102089	102268	102246
17	1.00	100	26.0	12.0	9.0	3	16.00		142709		
17	1.50	100	26.0	12.0	9.0	3	15.50		142710		
18	0.75	110	26.0	14.0	11.0	4	17.25		142711		
18	1.00	110	26.0	14.0	11.0	4	17.00	101881	102095		
18	1.50	110	26.0	14.0	11.0	4	16.50	101882	102096	102270	
18	2.00	125	33.0	14.0	11.0	3	16.00		142712		

* N410-3 =  4

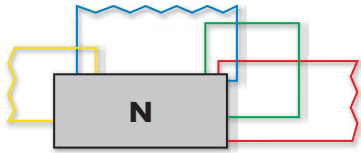

N410-3

N420-4

N420V-4

N410-3





N420-4

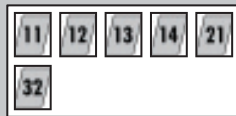

N420V-4













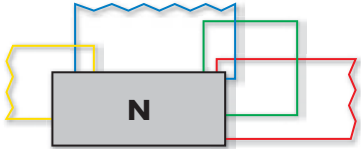

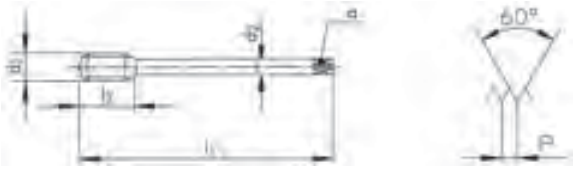

$\varnothing d_1$ MF	P mm	l_1 mm	l_2 mm	d_2 mm	a mm		
19	1.00	110	26.0	14.0	11.0	4	18.00
20	1.00	125	28.0	16.0	12.0	4	19.00
20	1.50	125	28.0	16.0	12.0	4	18.50
20	2.00	140	36.0	16.0	12.0	3	18.00
22	1.00	125	28.0	18.0	14.5	4	21.00
22	1.50	125	28.0	18.0	14.5	4	20.50
22	2.00	140	36.0	18.0	14.5	3	20.00
24	1.00	140	30.0	18.0	14.5	4	23.00
24	1.50	140	30.0	18.0	14.5	4	22.50
24	2.00	140	34.0	18.0	14.5	4	22.00
25	1.00	140	30.0	18.0	14.5	4	24.00
25	1.50	140	30.0	18.0	14.5	4	23.50
25	2.00	140	34.0	18.0	14.5	4	23.00
26	1.00	140	30.0	18.0	14.5	4	25.00
26	1.50	140	30.0	18.0	14.5	4	24.50
26	2.00	140	34.0	18.0	14.5	4	24.00
27	1.50	140	34.0	20.0	16.0	4	25.50
27	2.00	140	34.0	20.0	16.0	4	25.00
28	1.00	140	30.0	20.0	16.0	4	27.00
28	1.50	140	30.0	20.0	16.0	4	26.50
28	2.00	140	30.0	20.0	16.0	4	26.00
30	1.00	150	32.0	22.0	18.0	4	29.00
30	1.50	150	32.0	22.0	18.0	4	28.50
30	2.00	150	32.0	22.0	18.0	4	28.00

ID

ID

ID

	142713	
	102098	
101884	102099	102272
105130	102100	
	102104	
101886	102105	102274
101887	142714	
	102107	
101889	102108	102276
101890	102109	102277
	142722	
101892	102112	
	142723	
	102113	
101893	102114	
	* 142724	
	102115	
101894	102116	
	142725	
101896	102118	
122023		
101898	102121	
101899	102122	
101900	102123	

									N410-3	N420-4	N420-3
									N410-3		
N420-4											
N420-3											
											
											
$\varnothing d_1$ MF	P mm	l_1 mm	l_2 mm	d_2 mm	a mm			ID	ID	ID	
32	1.00	150	32.0	22.0	18.0	4	31.00	101902			
32	1.50	150	32.0	22.0	18.0	4	30.50	101903	102126	143812	
32	2.00	150	32.0	22.0	18.0	4	30.00	101904	102127		
33	1.50	160	32.0	25.0	20.0	4	31.50	101905	102128		
33	2.00	160	32.0	25.0	20.0	4	31.00	101906	102129		
34	1.00	170	32.0	28.0	22.0	4	33.00	101908			
34	1.50	170	32.0	28.0	22.0	4	32.50	101909	102131		
35	1.50	170	32.0	28.0	22.0	4	33.50	101910	102132		
35	2.00	170	32.0	28.0	22.0	4	33.00	101911			
36	1.00	170	34.0	28.0	22.0	4	35.00		102133		
36	1.50	170	34.0	28.0	22.0	4	34.50	101912	102134		
36	2.00	170	34.0	28.0	22.0	4	34.00	101913	102135		
36	3.00	200	45.0	28.0	22.0	4	33.00	101914	102136		
38	1.00	170	34.0	28.0	22.0	4	37.00	101916	* 102138		
38	1.50	170	34.0	28.0	22.0	4	36.50	101917	102139		
38	2.00	170	34.0	28.0	22.0	4	36.00	101918			
39	1.50	170	34.0	32.0	24.0	4	37.50	101919			
39	2.00	170	34.0	32.0	24.0	4	37.00	101920			
39	3.00	200	45.0	32.0	24.0	4	36.00	101921			

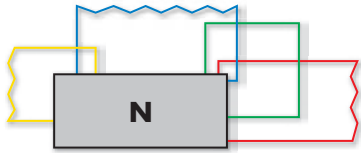

N410-3

N420-4

N420-3

N410-3





N420-4

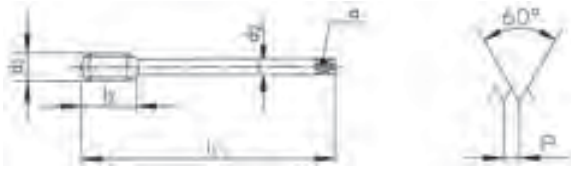

N420-3



$\varnothing d_1$ MF	P mm	l_1 mm	l_2 mm	d_2 mm	α mm		
40	1.00	170	34.0	32.0	24.0	5	39.00
40	1.50	170	34.0	32.0	24.0	5	38.50
40	2.00	170	34.0	32.0	24.0	5	38.00
40	3.00	200	45.0	32.0	24.0	4	37.00
42	1.50	170	34.0	32.0	24.0	5	40.50
42	2.00	170	34.0	32.0	24.0	5	40.00
42	3.00	200	45.0	32.0	24.0	4	39.00
45	1.50	180	34.0	36.0	29.0	5	43.50
45	2.00	180	34.0	36.0	29.0	5	43.00
45	3.00	200	45.0	36.0	29.0	4	42.00
48	1.50	190	36.0	36.0	29.0	5	46.50
48	2.00	190	36.0	36.0	29.0	5	46.00
48	3.00	220	48.0	36.0	29.0	5	45.00
50	1.50	190	36.0	36.0	29.0	5	48.50
50	2.00	190	36.0	36.0	29.0	5	48.00
50	3.00	220	48.0	36.0	29.0	5	47.00
52	1.50	190	36.0	40.0	32.0	5	50.50
52	2.00	190	36.0	40.0	32.0	5	50.00
52	3.00	220	48.0	40.0	32.0	5	49.00
55	2.00	190	40.0	40.0	32.0	5	53.00
60	2.00	220	42.0	45.0	35.0	5	58.00
63	1.50	220	38.0	45.0	35.0	5	61.50

ID

ID

ID

101925

101926

102152

143813

101927

102153

101928

102154

101929

102155

101930

102156

101931

102157

101933

102159

101934

* 102160

101935

102161

101937

102163

101938

102164

101939

102165

101943

102176

143814

101944

* 102177

* 101945

101946

101947

101948

105131

105132

143815

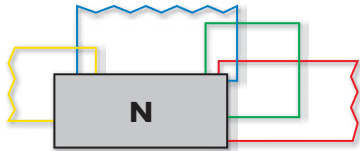

N410-3 LH

N420-4 LH

N410-3 LH



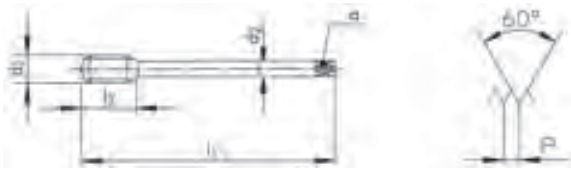

N420-4 LH













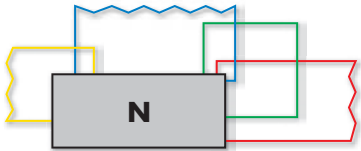

ISO 2
6H

ISO 2
6H



∅ d ₁ MF	P mm	l ₁ mm	l ₂ mm	d ₂ mm	a mm			ID	ID
4	0.50	63	14.0	2.8	2.1	3	3.50	104844	
5	0.50	70	15.0	3.5	2.7	3	4.50	104845	
6	0.50	80	17.0	4.5	3.4	3	5.50	104846	104870
6	0.75	80	17.0	4.5	3.4	3	5.25	104847	105133
7	0.75	80	17.0	5.5	4.3	3	6.25	104848	
8	0.50	90	20.0	6.0	4.9	3	7.50	104849	
8	0.75	90	20.0	6.0	4.9	3	7.25	104850	104871
8	1.00	90	20.0	6.0	4.9	3	7.00	104851	104872
10	0.75	100	22.0	7.0	5.5	3	9.25	104852	
10	1.00	100	22.0	7.0	5.5	3	9.00	104853	104873
10	1.25	100	22.0	7.0	5.5	3	8.80		104874
12	1.00	100	24.0	9.0	7.0	3	11.00	104854	104875
12	1.25	100	24.0	9.0	7.0	3	10.80	104855	104876
12	1.50	100	24.0	9.0	7.0	3	10.50	104856	104877
14	1.00	100	24.0	11.0	9.0	3	13.00	104857	104878
14	1.25	100	24.0	11.0	9.0	3	12.80	104858	
14	1.50	100	24.0	11.0	9.0	3	12.50	104859	104879
16	1.00	100	26.0	12.0	9.0	*3	15.00	104860	104880
16	1.50	100	26.0	12.0	9.0	*3	14.50	104861	104881
18	1.00	110	26.0	14.0	11.0	4	17.00	104862	
18	1.50	110	26.0	14.0	11.0	4	16.50	104863	104882
20	1.00	125	28.0	16.0	12.0	4	19.00	104864	
20	1.50	125	28.0	16.0	12.0	4	18.50	104865	104883
22	1.50	125	28.0	18.0	14.5	4	20.50	104866	104884
24	1.50	140	30.0	18.0	14.5	4	22.50	104867	104885
24	2.00	140	34.0	18.0	14.5	4	22.00	104868	104886
28	1.50	140	30.0	20.0	16.0	4	26.50	105166	* 105080
30	1.50	150	32.0	22.0	18.0	4	28.50	105167	105165
30	2.00	150	32.0	22.0	18.0	4	28.00	105168	



* N410-3 LH =  4

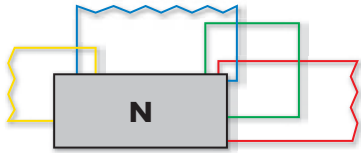

										N350-3	N450-3		
										ISO 2 6H	ISO 2 6H		
$\varnothing d_1$ MF	P mm	l_1 mm	l_2 mm	l_3 mm	d_2 mm	α mm				ID	ID		
4	0.50	63	14.0	21	4.5	3.4	2	3.50		101586			
5	0.50	70	15.0	25	6.0	4.9	3	4.50		101588			
6	0.75	80	17.0	30	6.0	4.9	3	5.25		101590			
8	1.00	90	20.0		6.0	4.9	3	7.00			102326		
9	0.75	90	20.0		7.0	5.5	3	8.25			102328		
10	1.00	100	22.0		7.0	5.5	3	9.00			102313		
12	1.00	100	24.0		9.0	7.0	3	11.00			102315		
12	1.50	100	24.0		9.0	7.0	3	10.50			102316		
14	1.50	100	24.0		11.0	9.0	3	12.50			102318		
16	1.50	100	26.0		12.0	9.0	3	14.50			102320		
18	1.50	110	26.0		14.0	11.0	4	16.50			102322		
20	1.50	125	28.0		16.0	12.0	4	18.50			102323		

									N360-3	N360V-3	N360TN-3	N360-3
												
N360-3												
N360V-3	 V											
N360TN-3	 TiN											
												
												
												
$\varnothing d_1$ MF	P mm	l_1 mm	l_2 mm	l_3 mm	d_2 mm	a mm		$6H$ $\rightarrow \leftarrow$	ID	ID	ID	ID $6H$ + mm
4	0.50	63	7.5	21	4.5	3.4	3	3.50	101632	101712	111618	101631 0.020
5	0.50	70	9.0	25	6.0	4.9	3	4.50	101641	101714	111617	101640 0.020
6	0.50	80	11.0	30	6.0	4.9	3	5.50	101648	143990		
6	0.75	80	11.0	30	6.0	4.9	3	5.25	101650	101716	101702	101649 0.022
8	0.75	90	12.5	35	8.0	6.2	3	7.25	101658	101719		101657 0.022
8	1.00	90	12.5	35	8.0	6.2	3	7.00	101660	101720	101704	101659 0.026
10	0.75	100	14.0	39	10.0	8.0	3	9.25	101606			
10	1.00	100	14.0	39	10.0	8.0	3	9.00	101608	101706	101695	101607 0.026
10	1.25	100	14.0	39	10.0	8.0	3	8.80	101609	105134	110965	



N460-3  

N460V-3   





N460TN-3   

N460-3	N460V-3	N460TN-3	N460-3
--------	---------	----------	--------

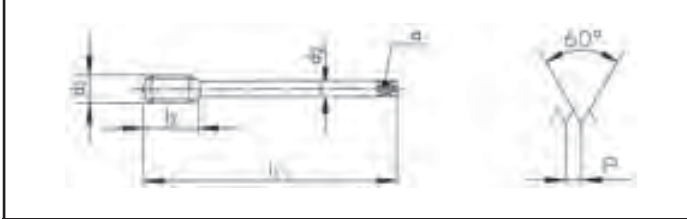

			
---	---	---	---



			
ISO 2 6H	ISO 2 6H	ISO 2 6H	ISO 3 6G

MF	∅ d ₁ mm	P mm	l ₁ mm	l ₂ mm	d ₂ mm	α mm		6H mm	ID	ID	ID	ID 6H + mm
12	1.00	100	14.0	9.0	7.0	3	11.00	102353	102462	102447	102352	0.026
12	1.25	100	14.0	9.0	7.0	3	10.80	102354	102463			
12	1.50	100	14.0	9.0	7.0	3	10.50	102356	102464	102448	102355	0.032
13	1.00	100	14.0	11.0	9.0	3	12.00	102364				
14	1.00	100	14.0	11.0	9.0	3	13.00	102365	102466			
14	1.50	100	14.0	11.0	9.0	3	12.50	102367	102467	102450	102366	0.032
15	1.00	100	14.0	12.0	9.0	3	14.00	102370				
15	1.50	100	18.0	12.0	9.0	3	13.50	102371				
16	1.00	100	14.0	12.0	9.0	4	15.00	102372	102469			
16	1.50	100	14.0	12.0	9.0	4	14.50	102374	102470	102452	102373	0.032
18	1.00	110	18.0	14.0	11.0	4	17.00	102380				
18	1.50	110	18.0	14.0	11.0	4	16.50	102382	102472		102381	0.032
20	1.00	125	20.0	16.0	12.0	4	19.00	102384				
20	1.50	125	20.0	16.0	12.0	4	18.50	102386	102474		* 102385	0.032
20	2.00	140	24.0	16.0	12.0	3	18.00	102387				
22	1.00	125	20.0	18.0	14.5	4	21.00	102392				
22	1.50	125	20.0	18.0	14.5	4	20.50	102393	102476			
24	1.50	140	22.0	18.0	14.5	4	22.50	102396	102478		* 110230	0.032
24	2.00	140	22.0	18.0	14.5	4	22.00	102397	102479			
25	1.50	140	22.0	18.0	14.5	4	23.50	102399				
26	1.50	140	22.0	18.0	14.5	4	24.50	102400	143952			
27	1.50	140	22.0	20.0	16.0	4	25.50	102401				
27	2.00	140	22.0	20.0	16.0	4	25.00	102402	144201			
28	1.50	140	22.0	20.0	16.0	4	26.50	102403				
30	1.50	150	24.0	22.0	18.0	4	28.50	102404	142524			
30	2.00	150	24.0	22.0	18.0	4	28.00	102405				
32	1.50	150	24.0	22.0	18.0	4	30.50	102406				
33	2.00	160	26.0	25.0	20.0	4	31.00	102407				
35	1.50	170	24.0	28.0	22.0	4	33.50	102408				
36	1.50	170	24.0	28.0	22.0	4	34.50	102409				

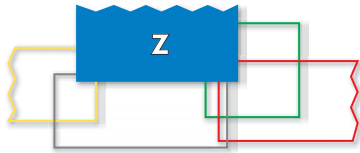

Z320V-4

Z320V-4

Z360V-3

Z360VS-3

Z320V-4



Z360V-3



Z360VS-3

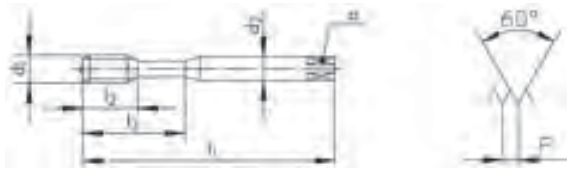
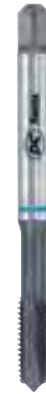

$\varnothing d_1$ MF	P mm	l_1 mm	l_2 mm	l_3 mm	d_2 mm	α mm			ID	ID
2	0.20	45	8.0		2.8	2.1	2	1.80		146487
2	0.25	45	8.0		2.8	2.1	2	1.75		114715
2.2	0.25	45	9.0		2.8	2.1	2	1.95		115462
2.5	0.20	50	10.0		2.8	2.1	3	2.30		115578
2.5	0.25	50	10.0		2.8	2.1	3	2.25		115887
3	0.35	56	12.0	18	3.5	2.7	3	2.65	115468	
6	0.75	80	17.0	30	6.0	4.9	3	5.25	142726	
8	1.00	90	20.0	35	8.0	6.2	3	7.00	142727	
10	1.00	100	22.0	39	10.0	8.0	3	9.00	142728	

$\varnothing d_1$ MF	P mm	l_1 mm	l_2 mm	l_3 mm	d_2 mm	α mm			ID	ID
4	0.50	63	7.5	21	4.5	3.4	3	3.50	104675	
5	0.50	70	9.0	25	6.0	4.9	3	4.50	104676	
6	0.75	80	11.0	30	6.0	4.9	3	5.25	104677	111552
8	1.00	90	12.5	35	8.0	6.2	3	7.00	104678	111553
10	1.00	100	14.0	39	10.0	8.0	3	9.00	104674	111554

MF ISO DIN 13

Z420

Z460

PM

HSSE



DIN 374

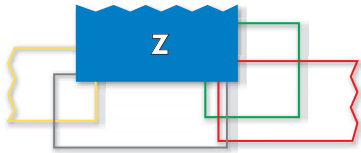

Z420V-4

Z460V-3

Z460VS-3

Z420V-4



Z460V-3



Z460VS-3

ISO 2
6HISO 2
6H

6HX

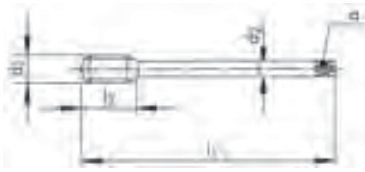

$\varnothing d_1$ MF	P mm	l_1 mm	l_2 mm	d_2 mm	a mm		
12	1.00	100	24.0	9.0	7.0	3	11.00
12	1.50	100	24.0	9.0	7.0	3	10.50
14	1.50	100	24.0	11.0	9.0	3	12.50
16	1.50	100	26.0	12.0	9.0	3	14.50

ID

142729

142730

142731

142732

$\varnothing d_1$ MF	P mm	l_1 mm	l_2 mm	d_2 mm	a mm		
12	1.00	100	14.0	9.0	7.0	3	11.00
12	1.50	100	14.0	9.0	7.0	*3	10.50
14	1.50	100	14.0	11.0	9.0	*3	12.50
16	1.50	100	14.0	12.0	9.0	4	14.50
18	1.50	110	18.0	14.0	11.0	4	16.50
20	1.50	125	20.0	16.0	12.0	4	18.50
22	1.50	125	20.0	18.0	14.5	4	20.50
24	1.50	140	22.0	18.0	14.5	4	22.50
24	2.00	140	22.0	18.0	14.5	4	22.00

ID

ID

104729

104730

104731

104732

104733

104734

104735

104736

104737

111555



111556

111557

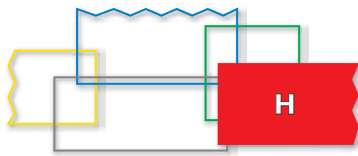
* Z460VS-3 = 4





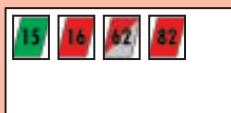

H320-4	H420-4		
--------	--------	--	--

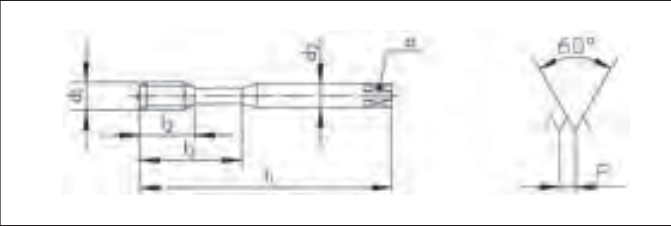
H320-4  

H420-4  



	
ISO 2 6H	ISO 2 6H

$\varnothing d_1$ MF	P mm	l_1 mm	l_2 mm	l_3 mm	d_2 mm	α mm			ID	ID
6	0.75	80	17.0	30	6.0	4.9	3	5.25	101214	
8	0.75	90	20.0	35	8.0	6.2	3	7.25	101216	
8	1.00	90	20.0	35	8.0	6.2	3	7.00	101217	
10	1.00	100	22.0	39	10.0	8.0	3	9.00	101204	
12	1.25	100	24.0		9.0	7.0	4	10.80		101273
12	1.50	100	24.0		9.0	7.0	4	10.50		101274
14	1.50	100	24.0		11.0	9.0	4	12.50		101276
16	1.50	100	26.0		12.0	9.0	4	14.50		101278
20	1.50	125	28.0		16.0	12.0	4	18.50		101282
20	2.00	140	36.0		16.0	12.0	4	18.00		* 101283
24	2.00	140	34.0		18.0	14.5	4	22.00		101285

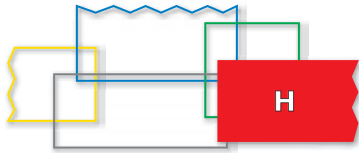

H350-3

H450-3

H350-3



H450-3



**ISO 2
6H**

**ISO 2
6H**

Ø d ₁ MF	P mm	l ₁ mm	l ₂ mm	l ₃ mm	d ₂ mm	α mm			ID	ID
6	0.75	80	11.0	30	6.0	4.9	3	5.25	101249	
8	0.75	90	12.5	35	8.0	6.2	3	7.25	101252	
8	1.00	90	12.5	35	8.0	6.2	3	7.00	101253	
10	1.00	100	14.0	39	10.0	8.0	3	9.00	101235	
12	1.00	100	14.0		9.0	7.0	4	11.00		101302
12	1.50	100	14.0		9.0	7.0	4	10.50		101303
14	1.50	100	14.0		11.0	9.0	4	12.50		101306
16	1.50	100	14.0		12.0	9.0	4	14.50		101308
18	1.50	110	18.0		14.0	11.0	4	16.50		101310
20	1.50	125	20.0		16.0	12.0	4	18.50		101312
22	1.50	125	20.0		18.0	14.5	4	20.50		101314
24	1.50	140	22.0		18.0	14.5	4	22.50		101316
24	2.00	140	22.0		18.0	14.5	4	22.00		101317
27	2.00	140	22.0		20.0	16.0	4	25.00		101319
30	1.50	150	24.0		22.0	18.0	4	28.50		101321
30	2.00	150	24.0		22.0	18.0	4	28.00		101322

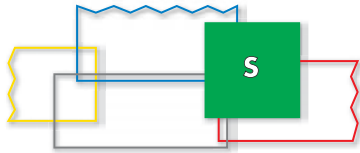

S320VS-4	S420VS-4	S360VS-3	S460VS-3
----------	----------	----------	----------



6HX	6HX	6HX	6HX

S320VS-4		VS	13 15 24 52
S420VS-4		VS	13 15 24 52
S360VS-3		VS	13 15 24 52
S460VS-3		VS	13 15 24 52

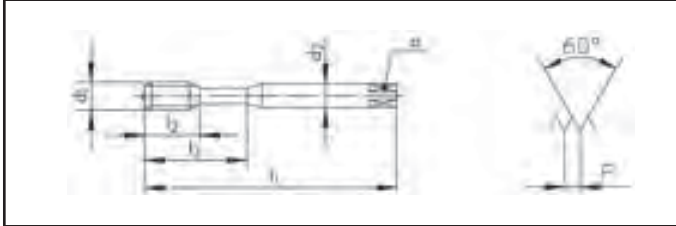

$\varnothing d_1$ MF	P mm	l_1 mm	l_2 mm	l_3 mm	d_2 mm	α mm			ID	ID
6	0.75	80	17.0	30	6.0	4.9	3	5.25	* 123690	
8	1.00	90	20.0	35	8.0	6.2	3	7.00	124288	
10	1.00	100	22.0	39	10.0	8.0	3	9.00	120059	
12	1.50	100	24.0		9.0	7.0	4	10.50		120420
14	1.50	100	24.0		11.0	9.0	4	12.50		120687
16	1.50	100	26.0		12.0	9.0	4	14.50		120877

$\varnothing d_1$ MF	P mm	l_1 mm	l_2 mm	l_3 mm	d_2 mm	α mm			ID	ID
6	0.75	80	11.0	30	6.0	4.9	3	5.25	* 111527	
8	1.00	90	12.5	35	8.0	6.2	3	7.00	111528	
10	1.00	100	14.0	39	10.0	8.0	3	9.00	111529	
12	1.50	100	14.0		9.0	7.0	4	10.50		111540
14	1.50	100	14.0		11.0	9.0	4	12.50		111541
16	1.50	100	14.0		12.0	9.0	4	14.50		111542

AERO

SA390-3

SA390-3



$\varnothing d_1$ MF	P mm	l_1 mm	l_2 mm	d_2 mm	a mm			ID
8	1.00	90	25.0	8.0	6.2	3	7.00	149735
10	1.00	100	30.0	10.0	8.0	3	9.00	149751
10	1.25	100	30.0	10.0	8.0	3	8.80	149753
12	1.00	110	35.0	12.0	9.0	4	11.00	149769
12	1.50	110	35.0	12.0	9.0	4	10.50	149773
14	1.50	110	40.0	16.0	12.0	4	12.50	149790

MF

AERO

										SA320-4	SA350-3	TL320VS-4	TL351VS-3																																																																																																	
<div style="display: flex; justify-content: space-between;"> <div style="width: 45%;"> <p>SA320-4 52 53</p> <p>SA350-3 52 53</p> <p>TL320VS-4 VS 41 42</p> <p>TL351VS-3 VS 41 42</p> </div> <div style="width: 50%; text-align: center;"> </div> </div>																																																																																																														
										<div style="display: flex; justify-content: space-around;"> <div style="border: 1px solid black; padding: 5px;">B 4 x P</div> <div style="border: 1px solid black; padding: 5px;">C 2.5 x P</div> <div style="border: 1px solid black; padding: 5px;">B 4 x P</div> <div style="border: 1px solid black; padding: 5px;">C 2.5 x P</div> </div>																																																																																																				
										<div style="display: flex; justify-content: space-around;"> <div style="border: 1px solid black; padding: 5px;">4HX</div> <div style="border: 1px solid black; padding: 5px;">4HX</div> <div style="border: 1px solid black; padding: 5px;">4HX</div> <div style="border: 1px solid black; padding: 5px;">4HX</div> </div>																																																																																																				
<table border="1" style="width: 100%; border-collapse: collapse; text-align: center;"> <thead> <tr> <th>∅ d₁ MF</th> <th>P mm</th> <th>l₁ mm</th> <th>l₂ mm</th> <th>l₃ mm</th> <th>d₂ mm</th> <th>α mm</th> <th></th> <th></th> </tr> </thead> <tbody> <tr><td>4</td><td>0.50</td><td>63</td><td>14.0</td><td></td><td>4.5</td><td>3.4</td><td>3</td><td>3.50</td></tr> <tr><td>5</td><td>0.50</td><td>70</td><td>15.0</td><td></td><td>6.0</td><td>4.9</td><td>3</td><td>4.50</td></tr> <tr><td>6</td><td>0.50</td><td>80</td><td>15.0</td><td>23</td><td>6.0</td><td>4.9</td><td>3</td><td>5.50</td></tr> <tr><td>8</td><td>0.75</td><td>90</td><td>18.0</td><td>29</td><td>8.0</td><td>6.2</td><td>3</td><td>7.25</td></tr> <tr><td>8</td><td>1.00</td><td>90</td><td>18.0</td><td>29</td><td>8.0</td><td>6.2</td><td>3</td><td>7.00</td></tr> <tr><td>10</td><td>1.00</td><td>100</td><td>20.0</td><td>33</td><td>10.0</td><td>8.0</td><td>3</td><td>9.00</td></tr> </tbody> </table>										∅ d ₁ MF	P mm	l ₁ mm	l ₂ mm	l ₃ mm	d ₂ mm	α mm			4	0.50	63	14.0		4.5	3.4	3	3.50	5	0.50	70	15.0		6.0	4.9	3	4.50	6	0.50	80	15.0	23	6.0	4.9	3	5.50	8	0.75	90	18.0	29	8.0	6.2	3	7.25	8	1.00	90	18.0	29	8.0	6.2	3	7.00	10	1.00	100	20.0	33	10.0	8.0	3	9.00	<table border="1" style="width: 100%; border-collapse: collapse; text-align: center;"> <thead> <tr> <th>ID</th> <th>ID</th> <th>ID</th> <th>ID</th> </tr> </thead> <tbody> <tr><td>149077</td><td>149079</td><td>152032</td><td>152033</td></tr> <tr><td>149142</td><td>149144</td><td>152048</td><td>152049</td></tr> <tr><td>149193</td><td>149195</td><td>152058</td><td>152059</td></tr> <tr><td>149296</td><td>149298</td><td>152075</td><td>152076</td></tr> <tr><td>149304</td><td>149306</td><td>152079</td><td>152080</td></tr> <tr><td>149362</td><td>149364</td><td>152092</td><td>152093</td></tr> </tbody> </table>										ID	ID	ID	ID	149077	149079	152032	152033	149142	149144	152048	152049	149193	149195	152058	152059	149296	149298	152075	152076	149304	149306	152079	152080	149362	149364	152092	152093
∅ d ₁ MF	P mm	l ₁ mm	l ₂ mm	l ₃ mm	d ₂ mm	α mm																																																																																																								
4	0.50	63	14.0		4.5	3.4	3	3.50																																																																																																						
5	0.50	70	15.0		6.0	4.9	3	4.50																																																																																																						
6	0.50	80	15.0	23	6.0	4.9	3	5.50																																																																																																						
8	0.75	90	18.0	29	8.0	6.2	3	7.25																																																																																																						
8	1.00	90	18.0	29	8.0	6.2	3	7.00																																																																																																						
10	1.00	100	20.0	33	10.0	8.0	3	9.00																																																																																																						
ID	ID	ID	ID																																																																																																											
149077	149079	152032	152033																																																																																																											
149142	149144	152048	152049																																																																																																											
149193	149195	152058	152059																																																																																																											
149296	149298	152075	152076																																																																																																											
149304	149306	152079	152080																																																																																																											
149362	149364	152092	152093																																																																																																											
										<div style="display: flex; justify-content: space-around;"> <div style="border: 1px solid black; padding: 5px;">6HX</div> <div style="border: 1px solid black; padding: 5px;">6HX</div> <div style="border: 1px solid black; padding: 5px;">6HX</div> <div style="border: 1px solid black; padding: 5px;">6HX</div> </div>																																																																																																				
<table border="1" style="width: 100%; border-collapse: collapse; text-align: center;"> <thead> <tr> <th>∅ d₁ MF</th> <th>P mm</th> <th>l₁ mm</th> <th>l₂ mm</th> <th>l₃ mm</th> <th>d₂ mm</th> <th>α mm</th> <th></th> <th></th> </tr> </thead> <tbody> <tr><td>4</td><td>0.50</td><td>63</td><td>14.0</td><td></td><td>4.5</td><td>3.4</td><td>3</td><td>3.50</td></tr> <tr><td>5</td><td>0.50</td><td>70</td><td>15.0</td><td></td><td>6.0</td><td>4.9</td><td>3</td><td>4.50</td></tr> <tr><td>6</td><td>0.50</td><td>80</td><td>15.0</td><td>23</td><td>6.0</td><td>4.9</td><td>3</td><td>5.50</td></tr> <tr><td>8</td><td>0.75</td><td>90</td><td>18.0</td><td>29</td><td>8.0</td><td>6.2</td><td>3</td><td>7.25</td></tr> <tr><td>8</td><td>1.00</td><td>90</td><td>18.0</td><td>29</td><td>8.0</td><td>6.2</td><td>3</td><td>7.00</td></tr> <tr><td>10</td><td>1.00</td><td>100</td><td>20.0</td><td>33</td><td>10.0</td><td>8.0</td><td>3</td><td>9.00</td></tr> </tbody> </table>										∅ d ₁ MF	P mm	l ₁ mm	l ₂ mm	l ₃ mm	d ₂ mm	α mm			4	0.50	63	14.0		4.5	3.4	3	3.50	5	0.50	70	15.0		6.0	4.9	3	4.50	6	0.50	80	15.0	23	6.0	4.9	3	5.50	8	0.75	90	18.0	29	8.0	6.2	3	7.25	8	1.00	90	18.0	29	8.0	6.2	3	7.00	10	1.00	100	20.0	33	10.0	8.0	3	9.00	<table border="1" style="width: 100%; border-collapse: collapse; text-align: center;"> <thead> <tr> <th>ID</th> <th>ID</th> <th>ID</th> <th>ID</th> </tr> </thead> <tbody> <tr><td>149081</td><td>149083</td><td>152034</td><td>152035</td></tr> <tr><td>149146</td><td>149148</td><td>152050</td><td>152051</td></tr> <tr><td>149197</td><td>149199</td><td>152060</td><td>152061</td></tr> <tr><td>149300</td><td>149302</td><td>152077</td><td>152078</td></tr> <tr><td>149308</td><td>149310</td><td>152081</td><td>148019</td></tr> <tr><td>149366</td><td>149368</td><td>152094</td><td>148026</td></tr> </tbody> </table>										ID	ID	ID	ID	149081	149083	152034	152035	149146	149148	152050	152051	149197	149199	152060	152061	149300	149302	152077	152078	149308	149310	152081	148019	149366	149368	152094	148026
∅ d ₁ MF	P mm	l ₁ mm	l ₂ mm	l ₃ mm	d ₂ mm	α mm																																																																																																								
4	0.50	63	14.0		4.5	3.4	3	3.50																																																																																																						
5	0.50	70	15.0		6.0	4.9	3	4.50																																																																																																						
6	0.50	80	15.0	23	6.0	4.9	3	5.50																																																																																																						
8	0.75	90	18.0	29	8.0	6.2	3	7.25																																																																																																						
8	1.00	90	18.0	29	8.0	6.2	3	7.00																																																																																																						
10	1.00	100	20.0	33	10.0	8.0	3	9.00																																																																																																						
ID	ID	ID	ID																																																																																																											
149081	149083	152034	152035																																																																																																											
149146	149148	152050	152051																																																																																																											
149197	149199	152060	152061																																																																																																											
149300	149302	152077	152078																																																																																																											
149308	149310	152081	148019																																																																																																											
149366	149368	152094	148026																																																																																																											



AERO

SA420-4

SA450-3

TL420VS-4

TL451VS-3



SA420-4



52 53

SA450-3



52 53

TL420VS-4



VS

41 42

TL451VS-3



VS

41 42



4HX

4HX

4HX

4HX

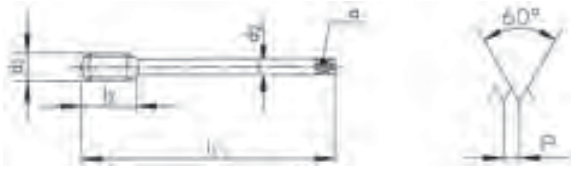

$\varnothing d_1$ MF	P mm	l_1 mm	l_2 mm	d_2 mm	a mm		
12	1.00	100	19.0	9.0	7.0	4	11.00
12	1.50	100	24.0	9.0	7.0	4	10.50
14	1.50	100	24.0	11.0	9.0	4	12.50
16	1.00	100	23.0	12.0	9.0	4	15.00
16	1.50	100	26.0	12.0	9.0	4	14.50

ID

ID

ID

ID

152209	148964	152218	152223
152208	152213	152217	152222
152210	152214	152219	152224
152211	152215	152220	152225
152212	152216	152221	152226

6HX

6HX

6HX

6HX

$\varnothing d_1$ MF	P mm	l_1 mm	l_2 mm	d_2 mm	a mm		
12	1.00	100	19.0	9.0	7.0	4	11.00
12	1.50	100	24.0	9.0	7.0	4	10.50
14	1.50	100	24.0	11.0	9.0	4	12.50
16	1.00	100	23.0	12.0	9.0	4	15.00
16	1.50	100	26.0	12.0	9.0	4	14.50

ID

ID

ID

ID

152228	148967	152237	152242
152227	152232	152236	152241
152229	152233	152238	152243
152230	152234	152239	152244
152231	152235	152240	152245



Uniquement pour taraudage synchrone
Nur für Synchronbearbeitung
Only for rigid tapping
Solo per maschiatura sincrona
Solo para roscado sincronizado



RTS Rigid Tapping Synchro

RTS320VS-4



11	12	13	14
15	21	22	31
32	61	63	72
73	74		

RTS420VS-4



11	12	13	14
15	21	22	31
32	61	63	72
73	74		

RTS362VS-3



11	12	13	14
15	21	22	31
32	61	63	72
73	74		

RTS462VS-3



RTS320VS-4

RTS420VS-4

RTS362VS-3

RTS462VS-3



∅ d ₁ MF	P mm	l ₁ mm	l ₂ mm	l ₃ mm	d ₂ h6 mm	α mm		
8	1.00	90	12.5	35	8.0	6.2	3	7.00
10	1.00	100	14.0	39	10.0	8.0	3	9.00
12	1.50	110	14.0		*10.0	*8.0	3	10.50
14	1.50	110	14.0		*12.0	*9.0	3	12.50
16	1.50	110	18.0		12.0	9.0	3	14.50

* Norme DC / * DC Norm / * Norma DC

∅ d ₁ MF	P mm	l ₁ mm	l ₂ mm	l ₃ mm	d ₂ h6 mm	α mm		
8	1.00	90	12.5	35	8.0	6.2	3	7.00
10	1.00	100	14.0	39	10.0	8.0	3	9.00
12	1.50	110	14.0		*10.0	*8.0	3	10.50
14	1.50	110	14.0		*12.0	*9.0	3	12.50
16	1.50	110	18.0		12.0	9.0	3	14.50

* Norme DC / * DC Norm / * Norma DC



sur demande
auf Anfrage
on request
su richiesta
sobre pedido



264/265



FP FORMING

FP381CN-3 FP481CN-3 FP381VS-3 FP481VS-3



FP381CN-3

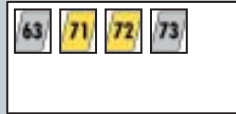

FP481CN-3

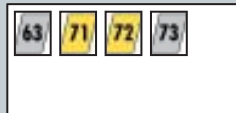

FP381VS-3

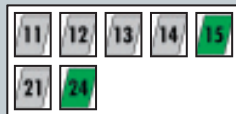

FP481VS-3

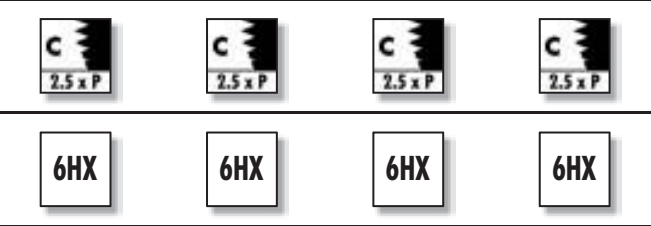
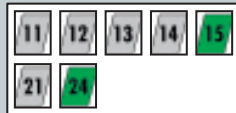

∅ d ₁ MF	P mm	l ₁ mm	l ₂ mm	l ₃ mm	d ₂ mm	α mm	Tol.
4	0.50	63	14.0	21	4.5	3.4	3.80 +/- 0.03
5	0.50	70	15.0	25	6.0	4.9	4.80 +/- 0.03
6	0.50	80	17.0	30	6.0	4.9	5.80 +/- 0.03
6	0.75	80	17.0	30	6.0	4.9	5.65 +/- 0.03
8	0.75	90	20.0	35	8.0	6.2	7.65 +/- 0.05
8	1.00	90	20.0	35	8.0	6.2	7.55 +/- 0.05
10	1.00	100	22.0	39	10.0	8.0	9.55 +/- 0.05
12	1.00	100	19.0	39	9.0	7.0	11.55 +/- 0.05
14	1.50	100	24.0	42	11.0	9.0	13.30 +/- 0.05
16	1.50	100	26.0	42	12.0	9.0	15.30 +/- 0.05

ID	ID	ID	ID
* 151126		151118	
* 151127		151119	
* 157163		157161	
151128		151120	
157164		157162	
151129		151121	
151130		151122	
	* 151131		151123
	* 151132		151124
	* 151133		151125





FA FORMING

FA381VS-3



VS

FA481VS-3



VS

12	13	14	15
21	22	23	24
41	51	61	63

FA381VS-3

FA481VS-3



6HX

6HX

∅ d ₁ MF	P mm	l ₁ mm	l ₂ mm	l ₃ mm	d ₂ mm	a mm	Tol.	
4	0.50	63	14.0	21	4.5	3.4	3.80	+/- 0.03
5	0.50	70	15.0	25	6.0	4.9	4.80	+/- 0.03
6	0.50	80	17.0	30	6.0	4.9	5.80	+/- 0.03
6	0.75	80	17.0	30	6.0	4.9	5.65	+/- 0.03
8	0.75	90	20.0	35	8.0	6.2	7.65	+/- 0.05
8	1.00	90	20.0	35	8.0	6.2	7.55	+/- 0.05
10	1.00	100	22.0	39	10.0	8.0	9.55	+/- 0.05
12	1.00	100	19.0		9.0	7.0	11.55	+/- 0.05
14	1.50	100	24.0		11.0	9.0	13.30	+/- 0.05
16	1.50	100	26.0		12.0	9.0	15.30	+/- 0.05

ID

ID

151110

151111

157159

151112

157160

151113

151114

151115

151116

151117



266/267



264/265

MF ISO DIN 13

≤ Ø 2.8 > Ø 2.8

PM HSSE



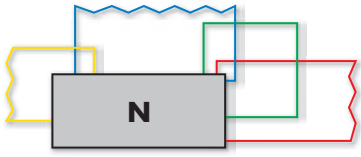

										N1110-1	N1110-3	N1110-S	N1120-4		
N1110-1															
N1110-3															
N1110-S															
N1120-4															
Ø d ₁ MF	P mm	l ₁ mm	l ₂ mm	l ₃ mm	d ₂ mm	a mm				ID	ID	ID	ID		
2	0.25	45	8.0		2.8	2.1	3	1.75			102933				
2.2	0.25	45	9.5		2.8	2.1	3	1.95			102936				
* 2.3	0.25	45	9.5		2.8	2.1	*3	2.05			* 102938		* 103046		
2.5	0.35	45	9.5		2.8	2.1	3	2.15			102940				
2.6	0.35	45	9.5		2.8	2.1	3	2.25					* 103064		
3	0.35	48	11.0	18	3.2	2.5	3	2.65			102945		* 103066		
3.5	0.35	50	13.0	20	3.5	2.8	3	3.15			102949				
4	0.35	53	13.0	21	4.0	3.2	3	3.65			102952				
4	0.50	53	13.0	21	4.0	3.2	3	3.50	102773	102953	111040				
4.5	0.50	53	13.0	21	4.5	3.5	3	4.00			102958				
5	0.35	58	16.0	25	5.0	4.0	3	4.65			102960				
5	0.50	58	16.0	25	5.0	4.0	3	4.50	102778	102961	111045				
5	0.75	58	16.0	25	5.0	4.0	3	4.25			102963				
5.5	0.50	62	17.0	26	5.6	4.5	3	5.00			102967		* 103084		
6	0.50	66	19.0	30	6.3	5.0	3	5.50	102783	102969	111050				
6	0.75	66	19.0	30	6.3	5.0	3	5.25	102784	102971	111051				
7	0.50	66	19.0	30	7.1	5.6	3	6.50			102975		* 103092		
8	0.50	72	22.0	35	8.0	6.3	3	7.50			* 102980				
8	0.75	72	22.0	35	8.0	6.3	3	7.25	102790	102982	111057				
8	1.00	72	22.0	35	8.0	6.3	3	7.00	102791	102984	111058				
9	0.50	72	22.0	36	9.0	7.1	3	8.50			102988				
9	0.75	72	22.0	36	9.0	7.1	3	8.25			102989				
9	1.00	72	22.0	36	9.0	7.1	3	8.00			102990		* 103105		
10	0.50	80	24.0	39	10.0	8.0	3	9.50			102925				
10	0.75	80	24.0	39	10.0	8.0	3	9.25			* 102926				
10	1.00	80	24.0	39	10.0	8.0	3	9.00	102756	102928	111024				
10	1.25	80	24.0	39	10.0	8.0	3	8.80	102758	102930	111025				
<p>* N1120-3 = 2 </p>															





N1210-1	N1210-3	N1210-S	N1220-4
---------	---------	---------	---------



N1210-1 



N1210-3  31 62 74

N1210-S 

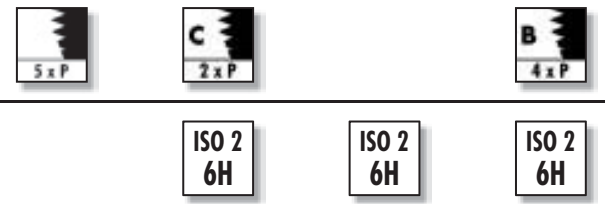
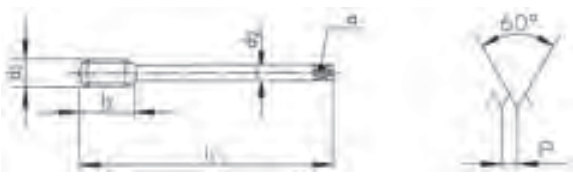
N1220-4  61 63 71 72 73 81



ISO 2 6H	ISO 2 6H	ISO 2 6H
-------------	-------------	-------------

∅ d ₁ MF	P mm	l ₁ mm	l ₂ mm	d ₂ mm	a mm		
11	0.50	85	22.0	8.0	6.3	3	10.50
11	0.75	85	22.0	8.0	6.3	3	10.25
11	1.00	85	22.0	8.0	6.3	3	10.00
11	1.25	85	22.0	8.0	6.3	3	9.80
12	0.50	89	24.0	9.0	7.1	3	11.50
12	0.75	89	24.0	9.0	7.1	3	11.25
12	1.00	89	24.0	9.0	7.1	3	11.00
12	1.25	89	24.0	9.0	7.1	3	10.80
12	1.50	89	24.0	9.0	7.1	3	10.50
14	0.50	95	24.0	11.2	9.0	3	13.50
14	0.75	95	24.0	11.2	9.0	3	13.25
14	1.00	95	24.0	11.2	9.0	3	13.00
14	1.25	95	24.0	11.2	9.0	3	12.80
14	1.50	95	24.0	11.2	9.0	3	12.50
15	0.75	90	23.0	11.2	9.0	3	14.25
15	1.00	90	23.0	11.2	9.0	3	14.00
16	0.50	102	32.0	12.5	10.0	4	15.50
16	0.75	102	32.0	12.5	10.0	4	15.25
16	1.00	102	32.0	12.5	10.0	4	15.00
16	1.50	102	32.0	12.5	10.0	4	14.50
17	0.75	95	23.0	12.5	10.0	4	16.25
17	1.00	95	23.0	12.5	10.0	4	16.00
17	1.50	102	26.0	12.5	10.0	*4	15.50

ID	ID	ID	ID
	103485		* 103657
	103486		
	103487		
	103488		
	103490		
	103491		
103305	103493	111169	
103307	103495	111171	
103308	103497	111172	
	103502		
	103503		
103312	103504	111175	
103314	103506	111177	
103315	103508	111178	
	103512		
* 103317	103513	* 111181	
	103515		
	103516		
103321	103517	111183	
103322	103520	111184	
	* 103524		
	103525		
			* 103693

* N1220-4 =  3

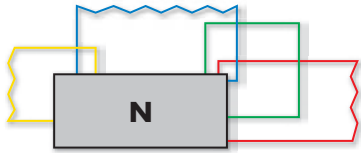

N1210-1 **N1210-3** **N1210-S** **N1220-4**



N1210-1



N1210-3





N1210-S

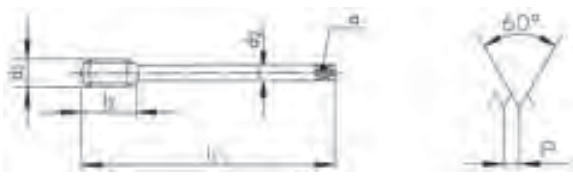

N1220-4



ISO 2 6H **ISO 2 6H** **ISO 2 6H**

∅ d ₁ MF	P mm	l ₁ mm	l ₂ mm	d ₂ mm	a mm		
18	0.75	112	30.0	14.0	11.2	4	17.25
18	1.00	112	30.0	14.0	11.2	4	17.00
18	1.50	112	30.0	14.0	11.2	4	16.50
18	2.00	112	30.0	14.0	11.2	3	16.00
19	1.00	112	33.0	14.0	11.2	4	18.00
20	1.00	112	37.0	14.0	11.2	4	19.00
20	1.25	112	37.0	14.0	11.2	4	18.80
20	1.50	112	37.0	14.0	11.2	4	18.50
22	1.00	115	32.0	16.0	12.5	4	21.00
22	1.50	115	32.0	16.0	12.5	4	20.50
22	2.00	115	32.0	16.0	12.5	3	20.00
24	1.00	120	30.0	18.0	14.0	4	23.00
24	1.50	120	30.0	18.0	14.0	4	22.50
24	2.00	130	45.0	18.0	14.0	4	22.00
25	1.00	120	30.0	18.0	14.0	4	24.00
25	1.50	120	30.0	18.0	14.0	4	23.50
25	2.00	120	30.0	18.0	14.0	4	23.00
26	1.00	120	30.0	18.0	14.0	4	25.00
26	1.50	120	30.0	18.0	14.0	4	24.50
26	2.00	120	30.0	18.0	14.0	4	24.00
27	1.00	127	30.0	20.0	16.0	4	26.00
27	1.50	127	30.0	20.0	16.0	4	25.50
27	2.00	135	45.0	20.0	16.0	4	25.00
28	1.00	127	30.0	20.0	16.0	4	27.00
28	1.50	127	30.0	20.0	16.0	4	26.50
30	1.50	127	32.0	20.0	16.0	4	28.50
30	2.00	127	32.0	20.0	16.0	4	28.00

ID	ID	ID	ID
	103527		* 103694
103326	103528	111187	
103327	103531	111188	
	103533		
	103536		* 103702
103332	103537	111198	
	103539		
103334	103540	111195	
* 103339	103545	* 121620	
103340	103546	121669	
	103548		* 103712
	103552		
103343	103553	111202	
103344	103555	111203	* 103717
	103559		
	103560		
	103561		
	103562		
103346	103563	111207	
	103564		* 103725
	103565		
	103566		* 103726
103351	103567	111210	
	103570		
	103571		
103355	103575	111214	
103356	103577	111215	



www.dcswiss.com

- **eCatalogue**
- **eAssistant**
- **dxfl Download**





























DC SWISS SA























CH-2735 Malleray



























Tel. +41 32 491 63 63

Fax +41 32 491 64 64

E-mail: info@dcswiss.ch

		N					Z	
Характеристики Cechy charakterystyczne				 V	 R40 V	  	 V	 VS
					 	  		
Типы отверстий Typ otworu								
		N310-3	N320-3 N320-4	N320V-4	N360-3 N360V-3	N1110 -1-2-3-S	Z320V-3 Z320V-4	Z320VS-4
Длинный по DIN DIN długi	DIN 371	108	108	108	110		112	112
Короткий по ISO ISO krótki	ISO 529					122		
Класс точности Tolerancja	UNC 2B	108	108	108	110	122	112	112
Класс точности Tolerancja	UNC 2BX							
Класс точности Tolerancja	UNC 3B							
Класс точности Tolerancja	UNC(J) 3B		108		110			
		N410-3	N420-4	N420V-4	N460-3 N460V-3	N1210 -1-2-3-S	Z420V-4	Z420VS-4
Длинный по DIN DIN długi	DIN 376	109	109	109	111		112	112
Короткий по ISO ISO krótki	ISO 529					123		
Класс точности Tolerancja	UNC 2B	109	109	109	111	123	112	112
Класс точности Tolerancja	UNC 2BX							
Класс точности Tolerancja	UNC 3B							
Класс точности Tolerancja	UNC(J) 3B							

		Z		H		S		SA
Характеристики Cechy charakterystyczne		 V	 VS		 R25	 VS	 VS	
								
Типы отверстий Typ otworu								
		Z360V-3 Z362V-3	Z362VS-3	H320-4	H350-3	S320VS-4	S360VS-3	SA320-4
Длинный по DIN DIN długi	DIN 371	113	113	114	115	116	116	118
Длинный по DIN DIN długi	DIN 2184-1							
Класс точности Tolerancja	UNC 2B	113		114	115	116	116	118
Класс точности Tolerancja	UNC 2BX		113					
Класс точности Tolerancja	UNC 3B							
Класс точности Tolerancja	UNC(J) 3B							118
		Z462V-3	Z462VS-3	H420-4	H450-3	S420VS-4	S460VS-3	SA420-4
Длинный по DIN DIN długi	DIN 376	113	113	114	115	116	116	119
Длинный по DIN DIN długi	DIN 2184-1							
Класс точности Tolerancja	UNC 2B	113		114	115	116	116	119
Класс точности Tolerancja	UNC 2BX		113					
Класс точности Tolerancja	UNC 3B							
Класс точности Tolerancja	UNC(J) 3B							119

SA		TL		RTS		FS	FP	FA
								
		VS	VS	VS	VS	VS	VS	VS
								
								
SA350-3	SA390-3	TL320VS-4	TL351VS-3	RTS320VS-4	RTS362VS-3	FS380VS-3	FP381VS-3	FA381VS-3
118	117	118	118	120	120			
						121	121	121
118		118	118					
				120	120	121	121	121
118	117	118	118					
SA450-3		TL420VS-4	TL451VS-3	RTS420VS-4	RTS462VS-3			
119		119	119	120	120			
119		119	119					
				120	120			
119		119	119					











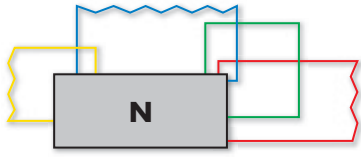

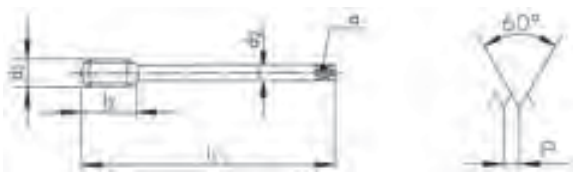

UNC ANSI B1.1

≤ Ø 2.8 > Ø 2.8

PM **HSSE**



										N310-3	N320-3	N320-4	N320V-4
N310-3													
N320-3													
N320-4													
N320V-4	V												
Ø" d ₁ UNC	P TPI	d ₁ mm	l ₁ mm	l ₂ mm	l ₃ mm	d ₂ mm	α mm			ID	ID	ID	ID
1	64	1.85	40	8.0		2.5	2.1	2	1.45		* 101467		
2	56	2.18	45	9.0		2.8	2.1	2	1.75		101469		
3	48	2.51	50	10.0		2.8	2.1	2	2.00		101470		
4	40	2.84	56	12.0	18	3.5	2.7	3	2.25	101450		101511	142738
5	40	3.17	56	12.0	18	3.5	2.7	3	2.55		* 101472	101512	
6	32	3.50	56	13.0	20	4.0	3.0	3	2.75	101451		101514	
8	32	4.16	63	14.0	21	4.5	3.4	3	3.40	101452		101515	142739
10	24	4.82	70	15.0	25	6.0	4.9	3	3.80	101449	* 101468	101508	142740
12	24	5.48	80	17.0	30	6.0	4.9	3	4.40			101509	
1/4	20	6.35	80	17.0	30	7.0	5.5	3	5.10	101448		101507	142741
Ø" d ₁ UNC	P TPI	d ₁ mm	l ₁ mm	l ₂ mm	l ₃ mm	d ₂ mm	α mm			ID	ID	ID	ID
4		40	2.84	56		12.0	18		3.5	2.7	3	2.30	145656
6		32	3.50	56		13.0	20		4.0	3.0	3	2.80	* 155317
8		32	4.16	63		14.0	21		4.5	3.4	3	3.45	* 155319

										N410-3	N420-4	N420V-4	
										N410-3			
													
													
													
\varnothing " d_1 UNC	P TPI	d_1 mm	l_1 mm	l_2 mm	d_2 mm	a mm				ID	ID	ID	
5/16	18	7.93	90	20.0	6.0	4.9	3	6.50	101997	102213	142742		
3/8	16	9.52	100	22.0	7.0	5.5	3	8.00	101996	102212	142743		
7/16	14	11.11	100	19.0	8.0	6.2	3	9.30		102215	142744		
1/2	13	12.70	110	24.0	9.0	7.0	3	10.80	101993	102208	142745		
9/16	12	14.28	110	28.0	11.0	9.0	3	12.20		102217			
5/8	11	15.87	110	30.0	12.0	9.0	3	13.60	101998	102214	142746		
3/4	10	19.05	125	33.0	14.0	11.0	3	16.60	101995	102211	142747		
7/8	9	22.22	140	36.0	18.0	14.5	3	19.50	* 101999	102216	142748		
1	8	25.40	160	39.0	18.0	14.5	4	22.30	101994	102209	142749		
1 1/8	7	28.57	180	45.0	22.0	18.0	4	25.00		102205			
1 1/4	7	31.75	180	45.0	22.0	18.0	4	28.20	101991	102204			
1 3/8	6	34.92	200	51.0	28.0	22.0	4	30.80		* 102207			
1 1/2	6	38.10	200	55.0	32.0	24.0	4	34.00	101990	102203			
1 3/4	5	44.45	220	59.0	36.0	29.0	4	39.50	101992	102206			
2	4.5	50.80	250	67.0	40.0	32.0	4	45.30		102210			

UNC ANSI B1.1











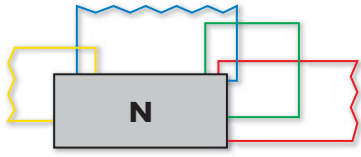









≤ Ø 2.8 > Ø 2.8

PM

HSSE

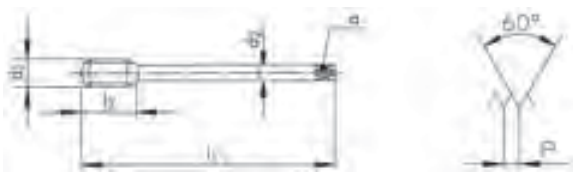

										N360-3	N360V-3	N360-3	
N360-3													
N360V-3	V												
N360-3													
										2B	2B	3B UNC(J)	
Ø" d ₁ UNC	P TPI	d ₁ mm	l ₁ mm	l ₂ mm	l ₃ mm	d ₂ mm	a mm			ID	ID	ID	
2	56	2.18	45	8.0		2.8	2.1	2	1.75	101673			
3	48	2.51	50	9.0		2.8	2.1	2	2.00	101674			
4	40	2.84	56	5.5	18	3.5	2.7	3	2.25	101676	101725	155316	
5	40	3.17	56	5.5	18	3.5	2.7	3	2.55	101677			
6	32	3.50	56	6.5	20	4.0	3.0	3	1.275	101679	101727	155318	
8	32	4.16	63	7.5	21	4.5	3.4	3	3.40	101680	101728	155320	
10	24	4.82	70	9.0	25	6.0	4.9	3	3.80	101671	101723		
12	24	5.48	80	11.0	30	6.0	4.9	3	4.40	101672			
1/4	20	6.35	80	11.0	30	7.0	5.5	3	5.10	101670	101722		
5/16	18	7.93	90	12.5	35	8.0	6.2	3	6.50	101678	101726		
3/8	16	9.52	100	14.0	39	10.0	8.0	3	8.00	101675	101724		
UNJC 1.280													

										N460-3	N460V-3						
																	
N460-3																	
N460V-3																	
																	
																	
																	
Ø" d ₁ UNC	P TPI	d ₁ mm	l ₁ mm	l ₂ mm	d ₂ mm	a mm				ID	ID						
7/16	14	11.11	100	14.0	8.0	6.2	3	9.30		102424	105135						
1/2	13	12.70	110	14.0	9.0	7.0	3	10.80		102420	102497						
9/16	12	14.28	110	14.0	11.0	9.0	3	12.20		102426	102502						
5/8	11	15.87	110	18.0	12.0	9.0	3	13.60		102423	102500						
3/4	10	19.05	125	21.0	14.0	11.0	3	16.60		102422	102499						
7/8	9	22.22	140	24.0	18.0	14.5	4	19.50		102425	102501						
1	8	25.40	160	27.0	18.0	14.5	4	22.30		102421	102498						
1 1/8	7	28.57	180	30.0	22.0	18.0	4	25.00		102418	102495						
1 1/4	7	31.75	180	30.0	22.0	18.0	4	28.20		102417	102494						
1 3/8	6	34.92	200	36.0	28.0	22.0	4	30.80		* 102419	* 102496						
1 1/2	6	38.10	200	40.0	32.0	24.0	4	34.00		102416	102493						
1 3/4	5	44.45	220	44.0	36.0	29.0	4	39.50			128062						
2	4.5	50.80	250	52.0	40.0	32.0	4	45.30			128084						

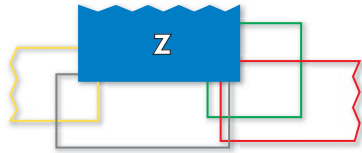

Z320V-4		V	21 22 23 41 42 51
Z320VS-4		VS	22 23 24 51 61
Z420V-4		V	21 22 23 41 42 51
Z420VS-4		VS	22 23 24 51 61

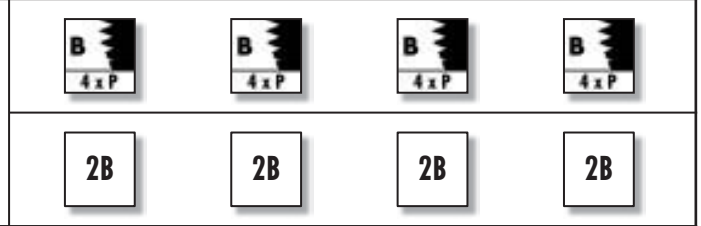
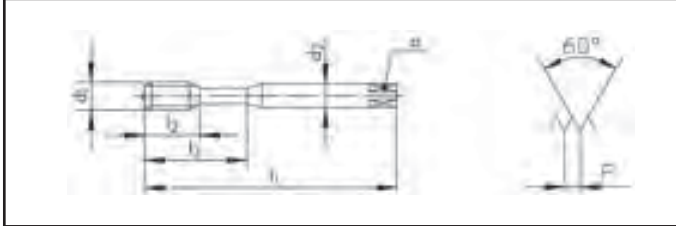
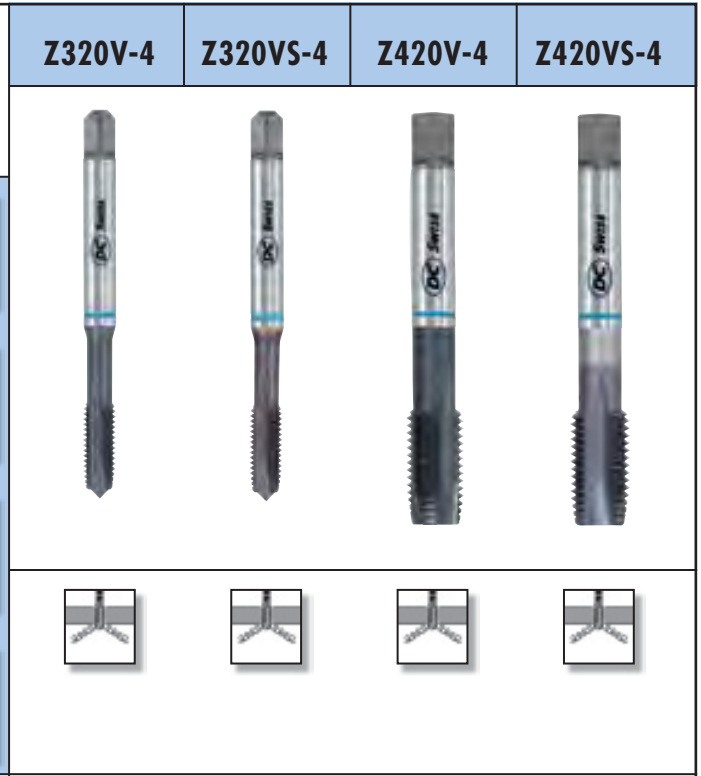

Ø" d ₁ UNC	P TPI	d ₁ mm	l ₁ mm	l ₂ mm	l ₃ mm	d ₂ mm	α mm			ID	ID	ID	ID
*2	56	2.18	45	9.0		2.8	2.1	2	1.75	142750			
4	40	2.84	56	12.0	18	3.5	2.7	3	2.25	142751			
6	32	3.50	56	13.0	20	4.0	3.0	3	2.75	142752	111560		
8	32	4.16	63	14.0	21	4.5	3.4	3	3.40	142753	111561		
10	24	4.82	70	15.0	25	6.0	4.9	3	3.80	142754	111562		
1/4	20	6.35	80	17.0	30	7.0	5.5	3	5.10	142755	111563		
5/16	18	7.93	90	20.0	35	8.0	6.2	3	6.50	142756	111564		
3/8	16	9.52	100	22.0	39	10.0	8.0	3	8.00	142757	111565		
1/2	13	12.70	110	24.0		9.0	7.0	3	10.80			142758	111566
5/8	11	15.87	110	30.0		12.0	9.0	3	13.60			142759	111567
3/4	10	19.05	125	33.0		14.0	11.0	4	16.60			142760	111568
7/8	9	22.22	140	36.0		18.0	14.5	4	19.50			142761	
1	8	25.40	160	39.0		18.0	14.5	4	22.30			142762	

* Z320V-3

UNC ANSI B1.1

≤ Ø 2.8 > Ø 2.8

PM HSSE

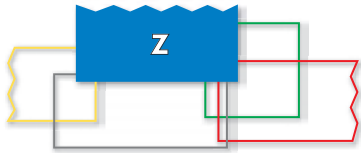

Z362V-3

Z362VS-3

Z462V-3

Z462VS-3



Z362V-3



22 23 41 51

Z362VS-3



22 23 24 51 61

Z462V-3



22 23 41 51

Z462VS-3



22 23 24 51 61



Ø" d ₁ UNC	P TPI	d ₁ mm	l ₁ mm	l ₂ mm	l ₃ mm	d ₂ mm	a mm		
*2	56	2.18	45	8.0		2.8	2.1	2	1.75
*4	40	2.84	56	5.5	18	3.5	2.7	3	2.25
6	32	3.50	56	6.5	20	4.0	3.0	3	2.75
8	32	4.16	63	7.5	21	4.5	3.4	3	3.40
10	24	4.82	70	9.0	25	6.0	4.9	3	3.80
1/4	20	6.35	80	11.0	30	7.0	5.5	3	5.10
5/16	18	7.93	90	12.5	35	8.0	6.2	3	6.50
3/8	16	9.52	100	14.0	39	10.0	8.0	3	8.00
7/16	14	11.11	100	14.0		8.0	6.2	3	9.30
1/2	13	12.70	110	14.0		9.0	7.0	*3	10.80
5/8	11	15.87	110	18.0		12.0	9.0	*3	13.60
3/4	10	19.05	125	21.0		14.0	11.0	*3	16.60
7/8	9	22.22	140	24.0		18.0	14.5	3	19.50
1	8	25.40	160	27.0		18.0	14.5	4	22.30

ID

ID

ID

ID

104695

104697

104699

111543

104700

111544

104694

111545

104693

111546

104698

111547

104696

111548

104757

111549

104753

111550

104756

111551

104755

111559

104758

104754

* Z360V-3

* Z462VS-3 = 4

										H320-4	H420-4		
H320-4													
H420-4													
Ø" d ₁ UNC	P TPI	d ₁ mm	l ₁ mm	l ₂ mm	l ₃ mm	d ₂ mm	α mm			ID	ID		
2	56	2.18	45	8.0		2.8	2.1	2	1.75	101221			
4	40	2.84	56	10.0	18	3.5	2.7	3	2.25	101223			
6	32	3.50	56	13.0	20	4.0	3.0	3	2.75	101225			
8	32	4.16	63	14.0	21	4.5	3.4	3	3.40	101226			
10	24	4.82	70	15.0	25	6.0	4.9	3	3.80	101220			
1/4	20	6.35	80	17.0	30	7.0	5.5	3	5.10	101219			
5/16	18	7.93	90	20.0	35	8.0	6.2	3	6.50	101224			
3/8	16	9.52	100	22.0	39	10.0	8.0	3	8.00	101222			
1/2	13	12.70	110	24.0		9.0	7.0	4	10.80		101290		

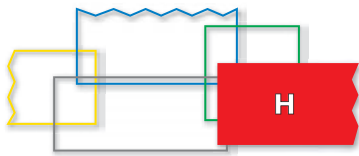

H350-3

H450-3

H350-3



H450-3

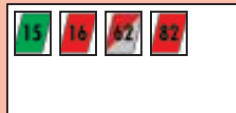

Ø" d ₁ UNC	P TPI	d ₁ mm	l ₁ mm	l ₂ mm	l ₃ mm	d ₂ mm	a mm		
2	56	2.18	45	8.0		2.8	2.1	2	1.75
4	40	2.84	56	5.5	18	3.5	2.7	3	2.25
6	32	3.50	56	6.5	20	4.0	3.0	3	2.75
8	32	4.16	63	7.5	21	4.5	3.4	3	3.40
10	24	4.82	70	9.0	25	6.0	4.9	3	3.80
1/4	20	6.35	80	11.0	30	7.0	5.5	3	5.10
5/16	18	7.93	90	12.5	35	8.0	6.2	3	6.50
3/8	16	9.52	100	14.0	39	10.0	8.0	3	8.00
7/16	14	11.11	100	14.0		8.0	6.2	3	9.30
1/2	13	12.70	110	14.0		9.0	7.0	4	10.80
5/8	11	15.87	110	18.0		12.0	9.0	4	13.60
3/4	10	19.05	125	21.0		14.0	11.0	4	16.60
1	8	25.40	160	27.0		18.0	14.5	4	22.30

ID

ID

101258

101260

101262

101263

101257

101256

101261

101259

101330

101326

101329

101328

101327

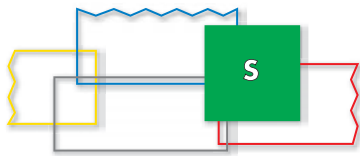

S320VS-4	S420VS-4	S360VS-3	S460VS-3
----------	----------	----------	----------

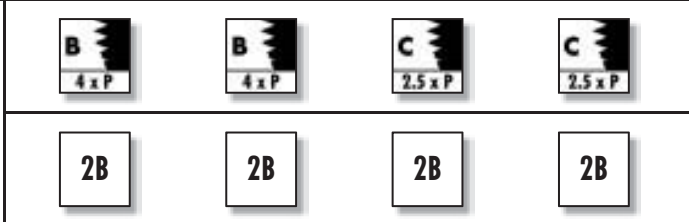

		ID	
2B	2B	2B	2B
111587	111588	111590	111591
111589	111592	111593	111594
		111595	

S320VS-4	VS	13 15 24 52
S420VS-4	VS	13 15 24 52
S360VS-3	VS	13 15 24 52
S460VS-3	VS	13 15 24 52

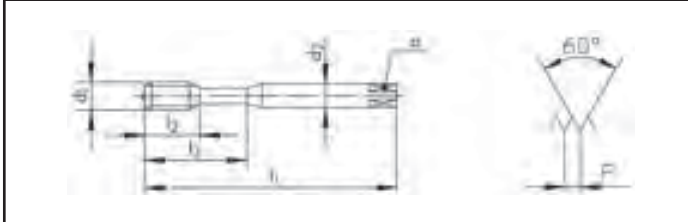

Ø" d ₁ UNC	P TPI	d ₁ mm	l ₁ mm	l ₂ mm	l ₃ mm	d ₂ mm	α mm		
6	32	3.50	56	13.0	20	4.0	3.0	3	2.75
8	32	4.16	63	14.0	21	4.5	3.4	3	3.40
10	24	4.82	70	15.0	25	6.0	4.9	3	3.80
1/4	20	6.35	80	17.0	30	7.0	5.5	3	5.10
5/16	18	7.93	90	20.0	35	8.0	6.2	3	6.50
3/8	16	9.52	100	22.0	39	10.0	8.0	3	8.00
1/2	13	12.70	110	24.0		9.0	7.0	4	10.80
5/8	11	15.87	110	30.0		12.0	9.0	4	13.60
3/4	10	19.05	125	33.0		14.0	11.0	4	16.60

Ø" d ₁ UNC	P TPI	d ₁ mm	l ₁ mm	l ₂ mm	l ₃ mm	d ₂ mm	α mm		
6	32	3.50	56	6.5	20	4.0	3.0	3	2.75
8	32	4.16	63	7.5	21	4.5	3.4	3	3.40
10	24	4.82	70	9.0	25	6.0	4.9	3	3.80
1/4	20	6.35	80	11.0	30	7.0	5.5	3	5.10
5/16	18	7.93	90	12.5	35	8.0	6.2	3	6.50
3/8	16	9.52	100	14.0	39	10.0	8.0	3	8.00
7/16	14	11.11	100	14.0		8.0	6.2	3	9.30
1/2	13	12.70	110	14.0		9.0	7.0	4	10.80
5/8	11	15.87	110	18.0		12.0	9.0	4	13.60
3/4	10	19.05	125	21.0		14.0	11.0	4	16.60

		ID	ID
		111530	
		111531	
		111532	
		111533	
		111534	
		111535	
			111536
			111537
			111538
			111539

AERO

SA390-3

SA390-3

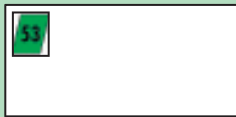

$\varnothing'' d_1$ UNC	P TPI	d_1 mm	l_1 mm	l_2 mm	d_2 mm	a mm		$\rightarrow \leftarrow$	ID
4	40	2.84	56	12.0	3.5	2.7	3	2.30	149652
6	32	3.50	56	13.0	4.0	3.0	3	2.80	149666
8	32	4.16	63	14.0	4.5	3.4	3	3.45	149677
10	24	4.82	70	15.0	6.0	4.9	3	3.90	149685
1/4	20	6.35	80	20.0	7.0	5.5	3	5.20	149713
5/16	18	7.93	90	25.0	8.0	6.2	3	6.70	149726
3/8	16	9.52	100	30.0	10.0	8.0	3	8.10	149747

AERO

SA320-4

SA350-3

TL320VS-4

TL351VS-3

SA320-4



SA350-3



TL320VS-4



VS



TL351VS-3



VS

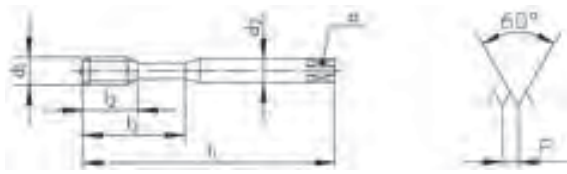
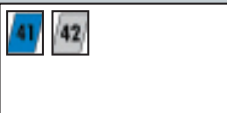

Ø" d ₁ UNC	P TPI	d ₁ mm	l ₁ mm	l ₂ mm	l ₃ mm	d ₂ mm	α mm		
4	40	2.84	56	12.0		3.5	2.7	3	2.25
5	40	3.17	56	12.0		3.5	2.7	3	2.55
6	32	3.50	56	13.0		4.0	3.0	3	2.75
8	32	4.16	63	14.0		4.5	3.4	3	3.40
10	24	4.82	70	15.0		6.0	4.9	3	3.80
12	24	5.48	80	15.0	23	6.0	4.9	3	4.40
1/4	20	6.35	80	15.0	23	7.0	5.5	3	5.10
5/16	18	7.93	90	18.0	29	8.0	6.2	3	6.50
3/8	16	9.52	100	20.0	33	10.0	8.0	3	8.00

ID ID ID ID

147271	149003	152000	152018
149031	149033	152023	152024
149055	149057	152027	152028
149093	149095	152036	152037
149125	149127	152042	152043
149174	149176	152054	152055
149222	149224	152062	127972
149269	149271	152067	152068
149346	149348	152084	152085



Ø" d ₁ UNC	P TPI	d ₁ mm	l ₁ mm	l ₂ mm	l ₃ mm	d ₂ mm	α mm		
4	40	2.84	56	12.0		3.5	2.7	3	2.30
5	40	3.17	56	12.0		3.5	2.7	3	2.60
6	32	3.50	56	13.0		4.0	3.0	3	2.80
8	32	4.16	63	14.0		4.5	3.4	3	3.45
10	24	4.82	70	15.0		6.0	4.9	3	3.90
12	24	5.48	80	15.0	23	6.0	4.9	3	4.55
1/4	20	6.35	80	15.0	23	7.0	5.5	3	5.20
5/16	18	7.93	90	18.0	29	8.0	6.2	3	6.70
3/8	16	9.52	100	20.0	33	10.0	8.0	3	8.10

ID ID ID ID

149005	149007	148804	150194
149035	149037	152025	152026
149059	149061	152029	150210
149097	149099	152038	152039
149129	149131	152044	152045
149178	149180	152056	152057
149226	149228	152063	152064
149273	149275	152069	152070
149350	149352	152086	152087

AERO

SA420-4

SA450-3

TL420VS-4

TL451VS-3

SA420-4



SA450-3



TL420VS-4



VS

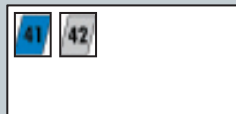

TL451VS-3



VS

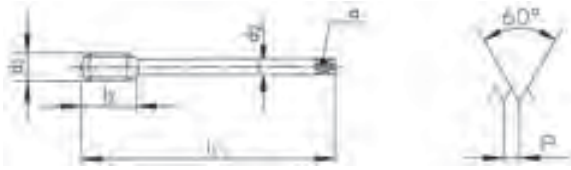
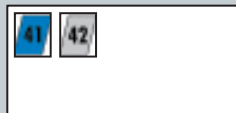

Ø" d ₁ UNC	P TPI	d ₁ mm	l ₁ mm	l ₂ mm	d ₂ mm	a mm		
7/16	14	11.11	100	22.0	8.0	6.2	*4	9.30
1/2	13	12.70	110	24.0	9.0	7.0	4	10.80
9/16	12	14.28	110	28.0	11.0	9.0	4	12.20
5/8	11	15.87	110	30.0	12.0	9.0	4	13.60
3/4	10	19.05	125	33.0	14.0	11.0	4	16.60

ID	ID	ID	ID
152246	152251	152256	152261
152247	152252	152257	152262
152248	152253		
152249	152254		
152250	152255		



Ø" d ₁ UNC	P TPI	d ₁ mm	l ₁ mm	l ₂ mm	d ₂ mm	a mm		
7/16	14	11.11	100	22.0	8.0	6.2	*4	9.40
1/2	13	12.70	110	24.0	9.0	7.0	4	10.90
9/16	12	14.28	110	28.0	11.0	9.0	4	12.40
5/8	11	15.87	110	30.0	12.0	9.0	4	13.80
3/4	10	19.05	125	33.0	14.0	11.0	4	16.70

ID	ID	ID	ID
152266	152271	152276	152281
152267	152272	152277	152282
152268	152273		
152269	152274		
152270	152275		

* SA420-4 = 3
 * TL420VS-4 = 3



Uniquement pour taraudage synchro
Nur für Synchrobearbeitung
Only for rigid tapping
Solo per maschiatura sincrona
Solo para roscado sincronizado



RTS Rigid Tapping Synchro

RTS320VS-4



VS

11	12	13	14
15	21	22	31
32	61	63	72
73	74		

RTS420VS-4



VS

11	12	13	14
15	21	22	31
32	61	63	72
73	74		

RTS362VS-3



VS

11	12	13	14
15	21	22	31
32	61	63	72
73	74		

RTS462VS-3



VS

11	12	13	14
15	21	22	31
32	61	63	72
73	74		

RTS320VS-4

RTS420VS-4

RTS362VS-3

RTS462VS-3



2BX

2BX

2BX

2BX

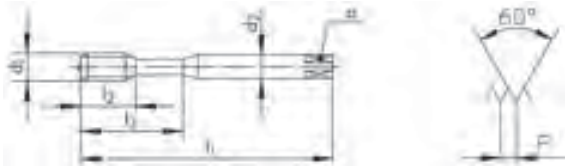

Ø" d ₁ UNC	P TPI	d ₁ mm	l ₁ mm	l ₂ mm	l ₃ mm	d ₂ h ₆ mm	α mm		
6	32	3.50	56	6.5	20	4.0(h9)	3.0	3	2.75
8	32	4.16	63	7.5	21	4.5(h9)	3.4	3	3.40
10	24	4.82	70	9.0	25	6.0	4.9	3	3.80
1/4	20	6.35	80	11.0	30	6.0	4.9	3	5.10
5/16	18	7.93	90	12.5	35	8.0	6.2	3	6.50
3/8	16	9.52	100	14.0	39	10.0	8.0	3	8.00
1/2	13	12.70	110	14.0		10.0	8.0	3	10.80

ID

ID

ID

ID

157395

157402

157396

157403

157397

157404

157398

157405

157399

157406

157400

157407

157401

157408



sur demande
auf Anfrage
on request
su richiesta
sobre pedido



264/265



FS FP FA FORMING

FS380VS-3		FP381VS-3	FA381VS-3
-----------	--	-----------	-----------

FS380VS-3 **VS**

11	12	13	14
15	21	22	23
24	41	51	61
63	71	72	73



FP381VS-3 **VS**

11	12	13	14	15
21	24			

FA381VS-3 **VS**

12	13	14	15	21	22
23	24	41	51	61	63

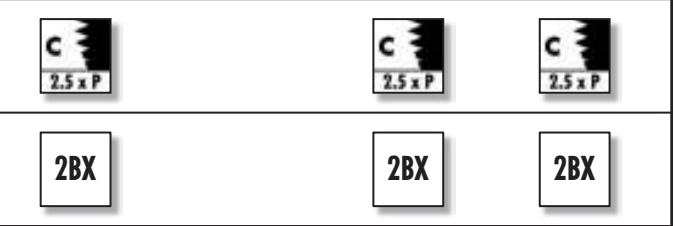
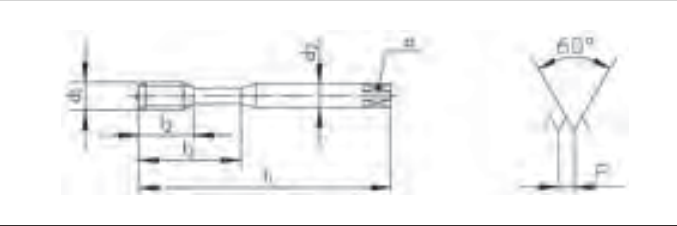
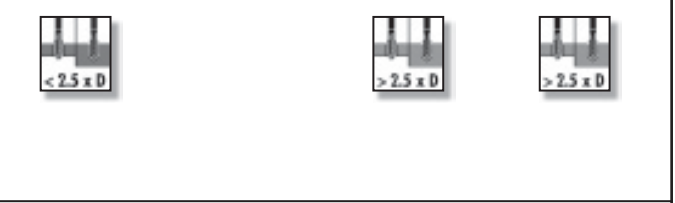







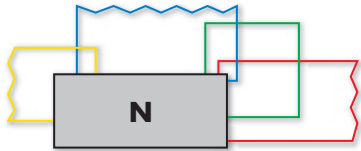

Ø" d ₁ UNC	P TPI	d ₁ mm	l ₁ mm	l ₂ mm	l ₃ mm	d ₂ mm	α mm	→ ← Tol.
2	56	2.18	45	9.0		2.8	2.1	1.95 +/- 0.02
4	40	2.84	56	12.0	18	3.5	2.7	2.55 +/- 0.03
6	32	3.50	56	13.0	20	4.0	3.0	3.15 +/- 0.03
8	32	4.16	63	14.0	21	4.5	3.4	3.80 +/- 0.03
10	24	4.82	70	15.0	25	6.0	4.9	4.35 +/- 0.03
1/4	20	6.35	80	17.0	30	7.0	5.5	5.75 +/- 0.03
5/16	18	7.93	90	20.0	35	8.0	6.2	7.30 +/- 0.03

ID	ID	ID
157285		
157287		
	157289	157310
	157290	157311
	157291	157312
	157292	157313
	157293	157314



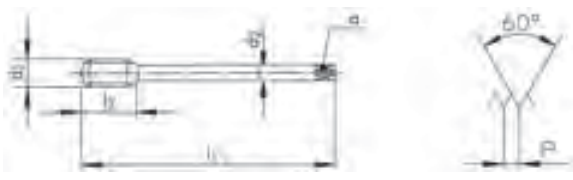

										N1110-1	N1110-2	N1110-3	N1110-S
N1110-1													
N1110-2													
N1110-3													
N1110-S													
												2B	2B
Ø" d ₁ UNC	P TPI	d ₁ mm	l ₁ mm	l ₂ mm	l ₃ mm	d ₂ mm	a mm			ID	ID	ID	ID
2	56	2.18	45	9.5		2.8	2.1	3	1.75	102799	102885	102998	111067
3	48	2.51	45	9.5		2.8	2.1	3	2.00	* 102800	* 102886	* 102999	* 111068
4	40	2.84	48	11.0	18	3.2	2.5	3	2.25	102802	102888	103001	111070
5	40	3.17	48	11.0	18	3.2	2.5	3	2.55	* 102803	* 102889	103002	* 111071
6	32	3.50	50	13.0	20	3.5	2.8	3	2.75	102805	102891	103004	111073
8	32	4.16	53	13.0	21	4.5	3.5	3	3.40	102806	102892	103005	111074
10	24	4.82	58	16.0	25	5.0	4.0	3	3.80	102797	102883	102996	111065
1/4	20	6.35	66	19.0	30	6.3	5.0	3	5.10	102796	102882	102995	111064
5/16	18	7.93	72	22.0	35	8.0	6.3	3	6.50	102804	102890	103003	111072
3/8	16	9.52	80	24.0	39	10.0	8.0	3	8.00	102801	102887	103000	111069

										N1210-1	N1210-2	N1210-3	N1210-S
										<p>N1210-1 </p> <p>N1210-2 </p> <p>N1210-3  31 62 74</p> <p>N1210-S </p>			
													
												2B 2B	
$\varnothing'' d_1$ UNC	P TPI	d_1 mm	l_1 mm	l_2 mm	d_2 mm	a mm			ϵ	ID	ID	ID	ID
7/16	14	11.11	85	22.0	8.0	6.3	3	9.30		103392	103466	103606	111236
1/2	13	12.70	89	24.0	9.0	7.1	3	10.80		103387	103461	103601	111229
5/8	11	15.87	102	32.0	12.5	10.0	3	13.60		103391	103465	103605	111235
3/4	10	19.05	112	33.0	14.0	11.2	3	16.60		103390	103464	103604	111234
1	8	25.40	130	45.0	18.0	14.0	4	22.30		103388	103462	103602	111230
1 3/8	6	34.92	162	57.0	25.0	20.0	4	30.80				* 110017	
1 3/4	5	44.45	187	67.0	31.5	25.0	4	39.50				* 111331	

eAssistant

<http://www.dcswiss.com/eAssistant>

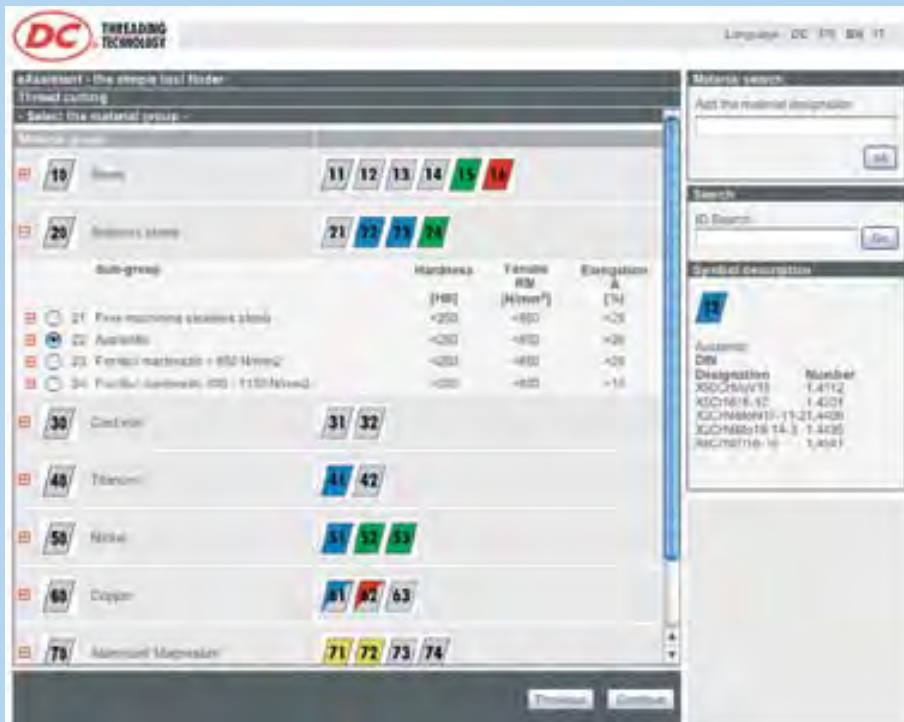



















































































































































































































































UNF, UNEF, UNS, UN

Указатель – Машинные и ручные метчики ANSI B1.1
Skorowidz – Gwintowniki maszynowe ANSI B1.1

		N						
Характеристики Cechy charakterystyczne								
Типы отверстий Typ otworu								
		N310-3	N320-3 N320-4	N320V-4	N360-3	N360V-3	N1110 -1-3-S	N1120-4
Длинный по DIN DIN długi	DIN 371	128	128	128	130	130		
Короткий по ISO ISO krótki	ISO 529						142	144
Класс точности Tolerancja	UNF 2B	128	128	128	130	130	142	
Класс точности Tolerancja	UNF 2BX							
Класс точности Tolerancja	UNF 3B							
Класс точности Tolerancja	UNF(J) 3B		128		130			
Класс точности Tolerancja	UNEF 2B						144	144
Класс точности Tolerancja	UNS 2B							
Класс точности Tolerancja	UN 2B							
		N410-3	N420-4	N420V-4	N460-3	N460V-3	N1210 -1-3-S	N1220-4
Длинный по DIN DIN długi	DIN 374	129	129	129	131	131		
Короткий по ISO ISO krótki	ISO 529						143	144
Класс точности Tolerancja	UNF 2B	129	129	129	131	131	143	
Класс точности Tolerancja	UNF 2BX							
Класс точности Tolerancja	UNF 3B							
Класс точности Tolerancja	UNF(J) 3B		129		131			
Класс точности Tolerancja	UNEF 2B						144	144
Класс точности Tolerancja	UNS 2B	145			145	145		
Класс точности Tolerancja	UN 2B				145	145		

UNF,
UNEF, UNS, UN

		Z			H		S	
Характеристики Cechy charakterystyczne								
								
								
Типы отверстий Typ otworu								
		Z320V-4	Z360V-3	Z360VS-3	H320-4	H350-3	S320VS-4	S360VS-3
Длинный по DIN DIN długi	DIN 371	132	133	133	134	135	136	136
Длинный по DIN DIN długi	DIN 2184-1							
Класс точности Tolerancja	UNF 2B	132	133		134	135		136
Класс точности Tolerancja	UNF 2BX			133				
Класс точности Tolerancja	UNF 3B							
Класс точности Tolerancja	UNF(J) 3B						136	136
Класс точности Tolerancja	UNEF 2B							
Класс точности Tolerancja	UNS 2B							
Класс точности Tolerancja	UN 2B							
		Z420V-4	Z460V-3	Z460VS-3	H420-4	H450-3	S420VS-4	S460VS-3
Длинный по DIN DIN długi	DIN 374	132	133	133	134	135	136	136
Длинный по DIN DIN długi	DIN 2184-1							
Класс точности Tolerancja	UNF 2B	132	133		134	135		136
Класс точности Tolerancja	UNF 2BX			133				
Класс точности Tolerancja	UNF 3B							
Класс точности Tolerancja	UNF(J) 3B						136	136
Класс точности Tolerancja	UNEF 2B							
Класс точности Tolerancja	UNS 2B							
Класс точности Tolerancja	UN 2B							

SA			TL		RTS		FP	FA
								
								
								
								
								
								
								
								
								
								
								
								
								
								
								
								
								
								
								
								
								
								
								
								
		</						

UNF ANSI B1.1

≤ Ø 2.8 > Ø 2.8











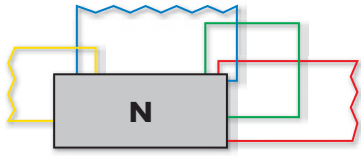

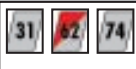

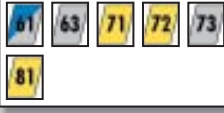





PM HSSE

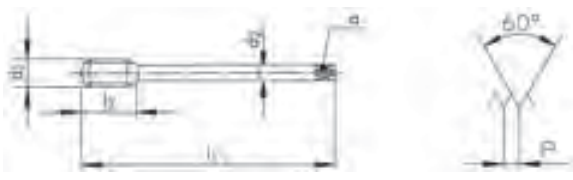

										N310-3	N320-3	N320-4	N320V-4
N310-3													
N320-3													
N320-4													
N320V-4	V												
Ø" d ₁ UNF	P TPI	d ₁ mm	l ₁ mm	l ₂ mm	l ₃ mm	d ₂ mm	a mm			ID	ID	ID	ID
0	80	1.52	40	7.0		2.5	2.1	2	1.20		101475		
1	72	1.85	40	8.0		2.5	2.1	2	1.50		101476		
2	64	2.18	45	9.0		2.8	2.1	2	1.80		101477		
3	56	2.51	50	10.0		2.8	2.1	3	2.10		* 101478		
4	48	2.84	56	12.0	18	3.5	2.7	3	2.35			128847	
5	44	3.17	56	12.0	18	3.5	2.7	3	2.60			142764	
6	40	3.50	56	13.0	20	4.0	3.0	3	2.90			101519	142765
8	36	4.16	63	14.0	21	4.5	3.4	3	3.50			101520	
10	32	4.82	70	15.0	25	6.0	4.9	3	4.05			101517	142766
12	28	5.48	80	17.0	30	6.0	4.9	3	4.60			101518	
1/4	28	6.35	80	17.0	30	7.0	5.5	3	5.50	101453		101516	142767
Ø" d ₁ UNF	P TPI	d ₁ mm	l ₁ mm	l ₂ mm	l ₃ mm	d ₂ mm	a mm			ID			
10	32	4.82	70	15.0	25	6.0	4.9	3	4.10		135506		
1/4	28	6.35	80	17.0	30	7.0	5.5	3	5.55		* 155323		





UNF ANSI B1.1



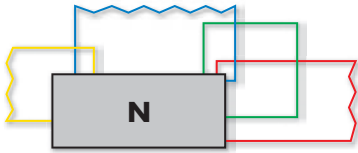

										N410-3	N420-4	N420V-4
										N410-3		
N420-4												
N420V-4	 V											
												
										2B	2B	2B
$\varnothing'' d_1$ UNF	P TPI	d_1 mm	l_1 mm	l_2 mm	d_2 mm	a mm			ϵ	ID	ID	ID
5/16	24	7.93	90	20.0	6.0	4.9	3	6.90		102004	102223	142774
3/8	24	9.52	100	22.0	7.0	5.5	3	8.50		102003	102222	142775
7/16	20	11.11	100	19.0	8.0	6.2	3	9.80		102006	102225	142776
1/2	20	12.70	100	24.0	9.0	7.0	3	11.40		102000	102219	142777
9/16	18	14.28	100	24.0	11.0	9.0	3	12.90			102227	
5/8	18	15.87	100	26.0	12.0	9.0	3	14.50		102005	102224	142778
3/4	16	19.05	125	33.0	14.0	11.0	4	17.50		102002	102221	142779
7/8	14	22.22	140	36.0	18.0	14.5	4	20.40		102007	102226	
1	12	25.40	160	39.0	18.0	14.5	4	23.30		* 102001	102220	142780
1 1/8	12	28.57	180	39.0	22.0	18.0	4	26.50			142773	
1 1/4	12	31.75	180	39.0	22.0	18.0	4	29.70			102218	
1 3/8	12	34.92	200	36.0	28.0	22.0	4	32.80			105137	
1 1/2	12	38.10	200	41.0	32.0	24.0	4	36.00		* 110986	105138	
										3B UNF(J)		
$\varnothing'' d_1$ UNF	P TPI	d_1 mm	l_1 mm	l_2 mm	d_2 mm	a mm			UNF	ID		
5/16	24	7.93	90	20.0	6.0	4.9	3	7.00		155328		
3/8	24	9.52	100	22.0	7.0	5.5	3	8.60		155326		
7/16	20	11.11	100	19.0	8.0	6.2	3	10.00		155330		
1/2	20	12.70	100	24.0	9.0	7.0	3	11.50		155321		

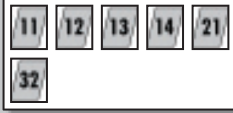
UNF

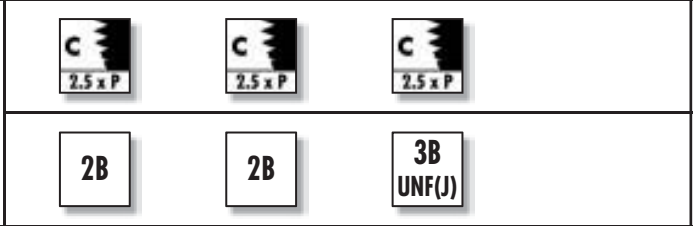
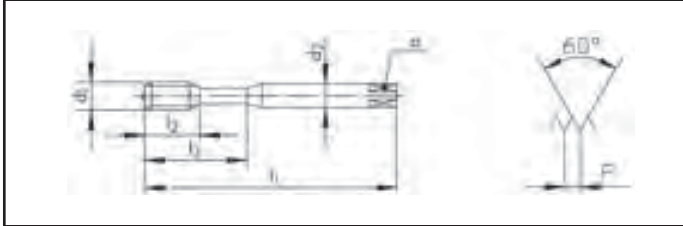

N360-3		
N360V-3	 V	
N360-3		



Ø" d ₁ UNF	P TPI	d ₁ mm	l ₁ mm	l ₂ mm	l ₃ mm	d ₂ mm	α mm			ID	ID	ID
6	40	3.50	56	6.5	20	4.0	3.0	3	2.90	101686		
8	36	4.16	63	7.5	21	4.5	3.4	3	3.50	101687	101733	
10	32	4.82	70	9.0	25	6.0	4.9	3	¹ 4.05	101682	101730	155325
12	28	5.48	80	11.0	30	6.0	4.9	3	4.60	101683		
1/4	28	6.35	80	11.0	30	7.0	5.5	3	² 5.50	101681	101729	155324
5/16	24	7.93	90	12.5	35	8.0	6.2	3	³ 6.90	101685	101732	155329
3/8	24	9.52	100	14.0	39	10.0	8.0	3	⁴ 8.50	101684	101731	155327

UNJF
¹4.10
²5.55
³7.00
⁴8.60

UNF ANSI B1.1

PM

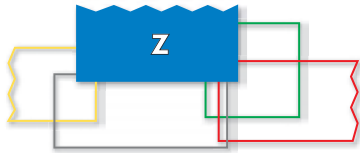

Z320V-4

Z420V-4

Z320V-4





Z420V-4



2B

2B

Ø" d ₁ UNF	P TPI	d ₁ mm	l ₁ mm	l ₂ mm	l ₃ mm	d ₂ mm	α mm		
10	32	4.82	70	15.0	25	6.0	4.9	3	4.05
1/4	28	6.35	80	17.0	30	7.0	5.5	3	5.50
5/16	24	7.93	90	20.0	35	8.0	6.2	3	6.90
3/8	24	9.52	100	22.0	39	10.0	8.0	3	8.50
7/16	20	11.11	100	19.0		8.0	6.2	3	9.80
1/2	20	12.70	100	24.0		9.0	7.0	3	11.40

ID

ID

142783

142784

142785

142786

142787

142788

UNF ANSI B1.1

HSSE

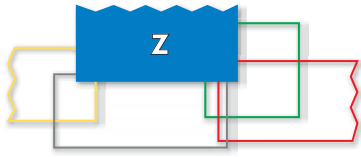

Z360V-3 Z360VS-3 Z460V-3 Z460VS-3

Z360V-3		V	
Z360VS-3		VS	
Z460V-3		V	
Z460VS-3		VS	

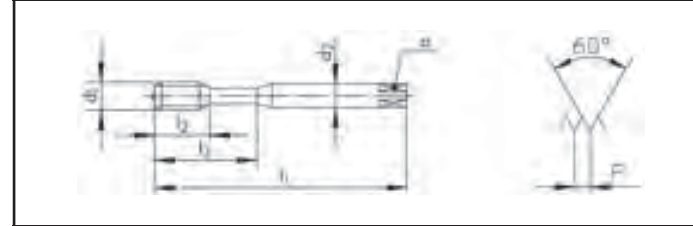

2B	2BX	2B	2BX

Ø" d ₁ UNF	P TPI	d ₁ mm	l ₁ mm	l ₂ mm	l ₃ mm	d ₂ mm	a mm		
10	32	4.82	70	9.0	25	6.0	4.9	3	4.05
1/4	28	6.35	80	11.0	30	7.0	5.5	3	5.50
5/16	24	7.93	90	12.5	35	8.0	6.2	3	6.90
3/8	24	9.52	100	14.0	39	10.0	8.0	3	8.50
7/16	20	11.11	100	14.0		8.0	6.2	3	9.80
1/2	20	12.70	100	14.0		9.0	7.0	*4	11.40
5/8	18	15.87	100	14.0		12.0	9.0	3	14.50
3/4	16	19.05	125	18.0		14.0	11.0	4	17.50

ID	ID	ID	ID
104680	111576		
104679	111575		
104682	111574		
104681	111573		
		104741	111572
		104738	111571
		104740	
		104739	

* Z460V-3 = 3

UNF

UNF ANSI B1.1

PM



										H320-4	H420-4		
H320-4													
H420-4													
\varnothing d ₁ UNF	P TPI	d ₁ mm	l ₁ mm	l ₂ mm	l ₃ mm	d ₂ mm	α mm			ID	ID		
10	32	4.82	70	15.0	25	6.0	4.9	3	4.05	101228			
1/4	28	6.35	80	17.0	30	7.0	5.5	3	5.50	101227			
5/16	24	7.93	90	20.0	35	8.0	6.2	3	6.90	105139			
3/8	24	9.52	100	22.0	39	10.0	8.0	3	8.50	101229			
1/2	20	12.70	100	24.0		9.0	7.0	4	11.40		101291		
3/4	16	19.05	125	33.0		14.0	11.0	4	17.50		* 101292		

UNF ANSI B1.1

PM

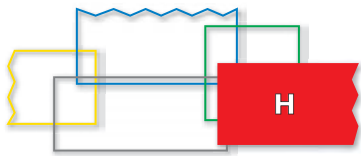

H350-3

H450-3

H350-3

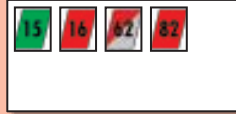

H450-3

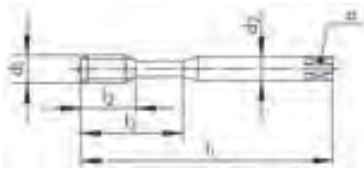

2B

2B

∅" d ₁ UNF	P TPI	d ₁ mm	l ₁ mm	l ₂ mm	l ₃ mm	d ₂ mm	α mm		
10	32	4.82	70	9.0	25	6.0	4.9	3	4.05
1/4	28	6.35	80	11.0	30	7.0	5.5	3	5.50
5/16	24	7.93	90	12.5	35	8.0	6.2	3	6.90
3/8	24	9.52	100	14.0	39	10.0	8.0	3	8.50
7/16	20	11.11	100	14.0		8.0	6.2	3	9.80
1/2	20	12.70	100	14.0		9.0	7.0	4	11.40
5/8	18	15.87	100	14.0		12.0	9.0	4	14.50
3/4	16	19.05	125	18.0		14.0	11.0	4	17.50

ID

ID

101265

101264

101267

101266

101334

101331

101333

101332

UNF

UNF ANSI B1.1

PM

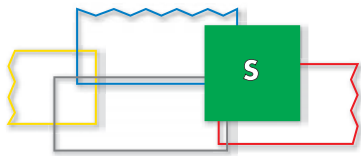

S320VS-4 S420VS-4 S360VS-3 S460VS-3



S320VS-4		VS	13 15 24 52
S420VS-4		VS	13 15 24 52
S360VS-3		VS	13 15 24 52
S460VS-3		VS	13 15 24 52

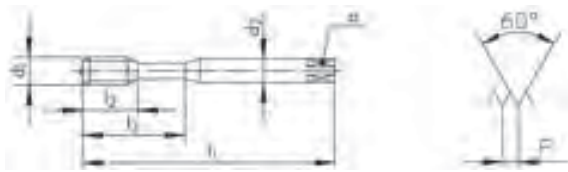
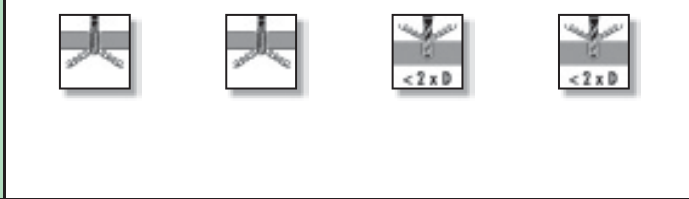

3B UNF(J)	3B UNF(J)	2B	2B

Ø" d ₁ UNF	P TPI	d ₁ mm	l ₁ mm	l ₂ mm	l ₃ mm	d ₂ mm	α mm		
10	32	4.82	70	15.0	25	6.0	4.9	3	4.10
1/4	28	6.35	80	17.0	30	7.0	5.5	3	5.55
5/16	24	7.93	90	20.0	35	8.0	6.2	3	7.00
3/8	24	9.52	100	22.0	39	10.0	8.0	3	8.60
7/16	20	11.11	100	22.0		8.0	6.2	3	10.00

ID	ID
111814	
111813	
111816	
111818	
	111837

Ø" d ₁ UNF	P TPI	d ₁ mm	l ₁ mm	l ₂ mm	l ₃ mm	d ₂ mm	α mm		
10	32	4.82	70	9.0	25	6.0	4.9	3	4.05
1/4	28	6.35	80	11.0	30	7.0	5.5	3	5.50
5/16	24	7.93	90	12.5	35	8.0	6.2	3	6.90
3/8	24	9.52	100	14.0	39	10.0	8.0	3	8.50
7/16	20	11.11	100	14.0		8.0	6.2	3	9.80
1/2	20	12.70	100	14.0		9.0	7.0	4	11.40

ID	ID
	111581
	111582
	111583
	111584
	111585
	111586

Ø" d ₁ UNF	P TPI	d ₁ mm	l ₁ mm	l ₂ mm	l ₃ mm	d ₂ mm	α mm		
10	32	4.82	70	9.0	25	6.0	4.9	3	4.10
1/4	28	6.35	80	11.0	30	7.0	5.5	3	5.55
5/16	24	7.93	90	12.5	35	8.0	6.2	3	7.00
3/8	24	9.52	100	14.0	39	10.0	8.0	3	8.60
7/16	20	11.11	100	14.0		8.0	6.2	3	10.00

ID	ID
	111815
	111820
	111817
	111819
	111833

AERO

SA390-3

SA390-3



Ø" d ₁ UNF	P TPI	d ₁ mm	l ₁ mm	l ₂ mm	d ₂ mm	α mm		UNF ↔	ID
4	48	2.84	56	12.0	3.5	2.7	3	2.35	* 149654
10	32	4.82	70	15.0	6.0	4.9	3	4.10	149687
1/4	28	6.35	80	20.0	7.0	5.5	3	5.55	149715
5/16	24	7.93	90	25.0	8.0	6.2	3	7.00	149728
3/8	24	9.52	100	30.0	10.0	8.0	3	8.60	149745

AERO

										SA320-4	SA350-3	TL320VS-4	TL351VS-3																																																																																														
SA320-4 SA350-3																																																																																																											
TL320VS-4 TL351VS-3																																																																																																											
<table border="1"> <thead> <tr> <th>\varnothing" d₁</th> <th>P</th> <th>d₁</th> <th>l₁</th> <th>l₂</th> <th>l₃</th> <th>d₂</th> <th>α</th> <th></th> <th></th> </tr> <tr> <th>UNF</th> <th>TPI</th> <th>mm</th> <th>mm</th> <th>mm</th> <th>mm</th> <th>mm</th> <th>mm</th> <th></th> <th></th> </tr> </thead> <tbody> <tr><td>4</td><td>48</td><td>2.84</td><td>56</td><td>12.0</td><td></td><td>3.5</td><td>2.7</td><td>3</td><td>2.35</td></tr> <tr><td>10</td><td>32</td><td>4.82</td><td>70</td><td>15.0</td><td></td><td>6.0</td><td>4.9</td><td>3</td><td>4.05</td></tr> <tr><td>1/4</td><td>28</td><td>6.35</td><td>80</td><td>15.0</td><td>23</td><td>7.0</td><td>5.5</td><td>3</td><td>5.50</td></tr> <tr><td>5/16</td><td>24</td><td>7.93</td><td>90</td><td>18.0</td><td>29</td><td>8.0</td><td>6.2</td><td>3</td><td>6.90</td></tr> <tr><td>3/8</td><td>24</td><td>9.52</td><td>100</td><td>20.0</td><td>33</td><td>10.0</td><td>8.0</td><td>3</td><td>8.50</td></tr> </tbody> </table>										\varnothing " d ₁	P	d ₁	l ₁	l ₂	l ₃	d ₂	α			UNF	TPI	mm	mm	mm	mm	mm	mm			4	48	2.84	56	12.0		3.5	2.7	3	2.35	10	32	4.82	70	15.0		6.0	4.9	3	4.05	1/4	28	6.35	80	15.0	23	7.0	5.5	3	5.50	5/16	24	7.93	90	18.0	29	8.0	6.2	3	6.90	3/8	24	9.52	100	20.0	33	10.0	8.0	3	8.50	<table border="1"> <thead> <tr> <th>ID</th> <th>ID</th> <th>ID</th> <th>ID</th> </tr> </thead> <tbody> <tr><td>149009</td><td>149011</td><td>152019</td><td>152020</td></tr> <tr><td>149133</td><td>149135</td><td>152046</td><td>152047</td></tr> <tr><td>149230</td><td>149232</td><td>152065</td><td>152066</td></tr> <tr><td>149277</td><td>149279</td><td>152071</td><td>152072</td></tr> <tr><td>149339</td><td>149341</td><td>152082</td><td>152083</td></tr> </tbody> </table>				ID	ID	ID	ID	149009	149011	152019	152020	149133	149135	152046	152047	149230	149232	152065	152066	149277	149279	152071	152072	149339	149341	152082	152083
\varnothing " d ₁	P	d ₁	l ₁	l ₂	l ₃	d ₂	α																																																																																																				
UNF	TPI	mm	mm	mm	mm	mm	mm																																																																																																				
4	48	2.84	56	12.0		3.5	2.7	3	2.35																																																																																																		
10	32	4.82	70	15.0		6.0	4.9	3	4.05																																																																																																		
1/4	28	6.35	80	15.0	23	7.0	5.5	3	5.50																																																																																																		
5/16	24	7.93	90	18.0	29	8.0	6.2	3	6.90																																																																																																		
3/8	24	9.52	100	20.0	33	10.0	8.0	3	8.50																																																																																																		
ID	ID	ID	ID																																																																																																								
149009	149011	152019	152020																																																																																																								
149133	149135	152046	152047																																																																																																								
149230	149232	152065	152066																																																																																																								
149277	149279	152071	152072																																																																																																								
149339	149341	152082	152083																																																																																																								
										<table border="1"> <thead> <tr> <th>ID</th> <th>ID</th> <th>ID</th> <th>ID</th> </tr> </thead> <tbody> <tr><td>149013</td><td>149015</td><td>152021</td><td>152022</td></tr> <tr><td>146098</td><td>149138</td><td>148005</td><td>148004</td></tr> <tr><td>146404</td><td>149235</td><td>148013</td><td>148012</td></tr> <tr><td>146393</td><td>149282</td><td>148017</td><td>148016</td></tr> <tr><td>147165</td><td>149344</td><td>148024</td><td>148023</td></tr> </tbody> </table>				ID	ID	ID	ID	149013	149015	152021	152022	146098	149138	148005	148004	146404	149235	148013	148012	146393	149282	148017	148016	147165	149344	148024	148023																																																																						
ID	ID	ID	ID																																																																																																								
149013	149015	152021	152022																																																																																																								
146098	149138	148005	148004																																																																																																								
146404	149235	148013	148012																																																																																																								
146393	149282	148017	148016																																																																																																								
147165	149344	148024	148023																																																																																																								



AERO

SA420-4

SA450-3

TL420VS-4

TL451VS-3

SA420-4



SA450-3



TL420VS-4



VS



TL451VS-3



VS

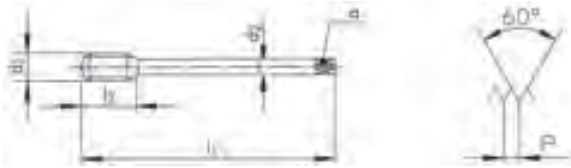
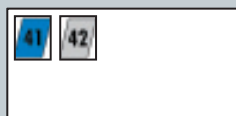

Ø" d ₁ UNF	P TPI	d ₁ mm	l ₁ mm	l ₂ mm	d ₂ mm	a mm		
7/16	20	11.11	100	22.0	8.0	6.2	*4	9.80
1/2	20	12.70	100	24.0	9.0	7.0	4	11.40
9/16	18	14.28	100	24.0	11.0	9.0	4	12.90
5/8	18	15.87	100	26.0	12.0	9.0	4	14.50

ID

ID

ID

ID

152286

152290

152294

152298

152287

152291

152295

152299

152288

152289

3B
UNF(J)

3B
UNF(J)

3B
UNF(J)

3B
UNF(J)

Ø" d ₁ UNF	P TPI	d ₁ mm	l ₁ mm	l ₂ mm	d ₂ mm	a mm			UNF
7/16	20	11.11	100	22.0	8.0	6.2	*4	10.00	
1/2	20	12.70	100	24.0	9.0	7.0	4	11.55	
9/16	18	14.28	100	24.0	11.0	9.0	4	13.05	
5/8	18	15.87	100	26.0	12.0	9.0	4	14.60	

ID

ID

ID

ID

147187

152302

152306

148031

147189

152303

152307

152310

146395

147169

* SA420-4 = 3

* TL420VS-4 = 3



RTS

Rigid Tapping Synchro

RTS320VS-4



VS

11	12	13	14
15	21	22	31
32	61	63	72
73	74		

RTS420VS-4



VS

11	12	13	14
15	21	22	31
32	61	63	72
73	74		

RTS362VS-3



VS

11	12	13	14
15	21	22	31
32	61	63	72
73	74		

RTS462VS-3



VS

11	12	13	14
15	21	22	31
32	61	63	72
73	74		

RTS320VS-4

RTS420VS-4

RTS362VS-3

RTS462VS-3



Ø" d ₁ UNF	P TPI	d ₁ mm	l ₁ mm	l ₂ mm	l ₃ mm	d ₂ h6 mm	α mm		
10	32	4.82	70	9.0	25	6.0	4.9	3	4.05
1/4	28	6.35	80	11.0	30	6.0	4.9	3	5.50
5/16	24	7.93	90	12.5	35	8.0	6.2	3	6.90
3/8	24	9.52	100	14.0	39	10.0	8.0	3	8.50
1/2	20	12.70	110	14.0		10.0	8.0	3	11.40

ID

ID

ID

ID

157409

157413

157410

157414

157411

157415

157412

157416

157417

157418



sur demande
auf Anfrage
on request
su richiesta
sobre pedido



264/265

<h2>FP FA FORMING</h2>										FP381VS-3	FA381VS-3
										<p>FP381VS-3 VS </p>	
<p>FA381VS-3 VS </p>											
										2BX	2BX
$\varnothing'' d_1$ UNF	P TPI	d_1 mm	l_1 mm	l_2 mm	l_3 mm	d_2 mm	α mm	$\rightarrow \leftarrow$	Tol.	ID	ID
6	40	3.50	56	13.0	20	4.0	3.0	3.20	+/- 0.03	* 157295	* 157316
10	32	4.82	70	15.0	25	6.0	4.9	4.45	+/- 0.03	157297	157318
1/4	28	6.35	80	17.0	30	7.0	5.5	5.95	+/- 0.03	157298	157319
5/16	24	7.93	90	20.0	35	8.0	6.2	7.45	+/- 0.03	157299	157320
266/267										264/265	

UNF ANSI B1.1

≤ Ø 2.8 > Ø 2.8

PM **HSSE**



										N1110-1	N1110-3	N1110-S		
N1110-1														
N1110-3														
N1110-S														
Ø" d ₁ UNF	P TPI	d ₁ mm	l ₁ mm	l ₂ mm	l ₃ mm	d ₂ mm	a mm			ID	ID	ID		
0	80	1.52	40	7.0		2.5	2.1	3	1.20	102811	103010	111079		
1	72	1.85	40	8.0		2.5	2.1	3	1.50	102812	103011	111080		
4	48	2.84	48	11.0	18	3.2	2.5	3	2.35	* 102819	103018	* 111087		
6	40	3.50	50	13.0	20	3.5	2.8	3	2.90	102822	103021	111090		
8	36	4.16	53	13.0	21	4.5	3.5	3	3.50	102823	103022	111091		
10	32	4.82	58	16.0	25	5.0	4.0	3	4.05	102814	103013	111082		
12	28	5.48	62	17.0	26	5.6	4.5	3	4.60	102815	103014	111083		
1/4	28	6.35	66	19.0	30	6.3	5.0	3	5.50	102813	103012	111081		
5/16	24	7.93	72	22.0	35	8.0	6.3	3	6.90	102821	103020	111089		
3/8	24	9.52	80	24.0	39	10.0	8.0	3	8.50	102818	103017	111086		

UNF ANSI B1.1

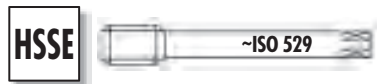

										N1210-1	N1210-3	N1210-S	
										N1210-1			
N1210-3													
N1210-S													
$\varnothing'' d_1$ UNF	P TPI	d_1 mm	l_1 mm	l_2 mm	d_2 mm	a mm				ID	ID	ID	
7/16	20	11.11	85	22.0	8.0	6.3	3	9.80		103411	103626	111255	
1/2	20	12.70	89	24.0	9.0	7.1	3	11.40		103407	103622	111251	
5/8	18	15.87	102	32.0	12.5	10.0	3	14.50		103410	103625	111254	
3/4	16	19.05	112	33.0	14.0	11.2	4	17.50		103409	103624	111253	
7/8	14	22.22	115	32.0	16.0	12.5	4	20.40		103412	103627	111256	
1	12	25.40	130	45.0	18.0	14.0	4	23.30		103408	103623	111252	

UNF



										N1110-3	N1120-4	N1210-3	N1220-4
N1110-3													
N1120-4													
N1210-3													
N1220-4													
Ø" d ₁	P	d ₁	l ₁	l ₂	l ₃	d ₂	α			ID	ID	ID	ID
UNEF	TPI	mm	mm	mm	mm	mm	mm						
12	32	5.48	62	17.0	26	5.6	4.5	3	4.70	103007	103118		
1/4	32	6.35	66	19.0	30	6.3	5.0	3	5.60	103006	103117		
5/16	32	7.93	72	22.0	35	8.0	6.3	3	7.20	103009	103120		
3/8	32	9.52	80	24.0	39	10.0	8.0	3	8.75	103008	103119		
7/16	28	11.11	85	22.0		8.0	6.3	3	10.25			103615	103754
1/2	28	12.70	89	24.0		9.0	7.1	3	11.85			103609	103749
9/16	24	14.28	95	24.0		11.2	9.0	3	13.20			103617	103756
5/8	24	15.87	102	32.0		12.5	10.0	3	14.80			103614	103753
11/16	24	17.46	104	26.0		14.0	11.2	*3	16.40			103611	103751
3/4	20	19.05	112	33.0		14.0	11.2	4	17.80			103613	103752
13/16	20	20.63	104	28.0		14.0	11.2	4	19.40			* 103612	
7/8	20	22.22	115	32.0		16.0	12.5	4	21.00			103616	* 103755
1	20	25.40	120	30.0		18.0	14.0	4	24.10			103610	* 103750

* N1210-3 = 4

UNS, UN ANSI B1.1

HSSE

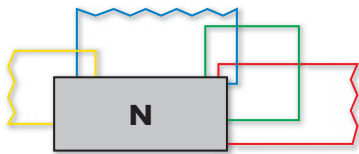

N410-3

N460-3

N460V-3

N410-3	N460-3	N460V-3	
--------	--------	---------	--



< 1.5 x D	< 2.5 x D	< 2.5 x D
-----------	-----------	-----------

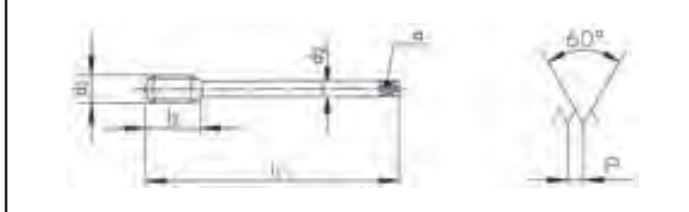

2.5 x P	2.5 x P	2.5 x P
2B	2B	2B

Ø" d ₁ UNS	P TPI	d ₁ mm	l ₁ mm	l ₂ mm	d ₂ mm	a mm		
1/4	36	6.35	80	17.0	4.5	3.4	3	5.65
1/2	24	12.70	100	24.0	9.0	7.0	3	11.60
1	14	25.40	140	34.0	18.0	14.5	4	23.60
1	14	25.40	140	22.0	18.0	14.5	4	23.60

















ID	ID	ID
104899		
104900		
104898		
	102437	142789

Ø" d ₁ UN	P TPI	d ₁ mm	l ₁ mm	l ₂ mm	d ₂ mm	a mm		
1 1/8	8	28.57	180	30.0	22.0	18.0	4	25.50
1 1/4	8	31.75	180	30.0	22.0	18.0	4	28.70
1 3/8	8	34.92	200	36.0	28.0	22.0	4	31.80
1 1/2	8	38.10	200	40.0	32.0	24.0	4	35.00
2	8	50.80	250	38.0	40.0	32.0	5	47.70

ID	ID
	102415
	142790
	102414
	142520
	104896
	142792
	102413
	142793
	111622











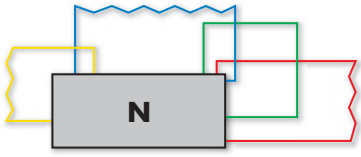



UNEF, UNS, UN

	N						
Характеристики Cechy charakterystyczne			 V	 TiN		 R40 V	 R40 V
Типы отверстий Typ otworu							
	N410-3	N420-4	N420V-4	N420TN-4	N460-3	N460V-3	N462V-3
Длинный по DIN DIN długi	DIN 5156	150	151	151	151	152	152
Короткий по ISO DIN krótki	DIN 5157						
Левая резьба LH Gwint lewy	DIN 5156	150					

	H	GG	RTS	FP	FA		
Характеристики Cechy charakterystyczne		 NI	 VS	 VS	 VS		
							
Типы отверстий Typ otworu							
							
	H450-3	GG450NI-3	RTS462VS-3	FP481VS-3	FA481VS-3		
Длинный по DIN DIN 5156	153	153					
Длинный по DIN DIN długi			155				
Длинный по DIN DIN długi				156	156		

	N						
Характеристики Cechy charakterystyczne		 	 1:16	 	 	 	
Типы отверстий Typ otworu							
				N1110-1	N1110-2	N1110-3	N1120-4
Короткий по ISO ISO krótki	ISO 529			160	160	160	160
W	ISO 529			160	160	160	160
	N420-3	N410-3	D5800	N1210-1	N1210-2	N1210-3	N1220-4
Длинный по DIN DIN długi	DIN 5156	158					
Длинный по DIN DIN długi	DC	158					
Короткий по ISO ISO krótki	ISO 529			161	161	161	161
Rp	DIN 5156	158					
Rc	DC	158	159				
W	ISO 529			161	161	161	161

G (BSP),
Rp, Rc, W

										N410-3		N410-3 LH					
										N410-3		N410-3 LH					
 																	
 																	
 																	
\varnothing d ₁ G	P TPI	d ₁ mm	l ₁ mm	l ₂ mm	d ₂ mm	a mm			ID	ID							
1/8	28	9.72	90	22.0	7.0	5.5	3	8.75	101855	* 101856							
1/4	19	13.15	100	20.0	11.0	9.0	3	11.60	101853	101854							
3/8	19	16.66	100	20.0	12.0	9.0	4	15.20	101861	101862							
1/2	14	20.95	125	22.0	16.0	12.0	4	18.90	101851	101852							
3/4	14	26.44	140	28.0	20.0	16.0	4	24.40	101859	101860							
1	11	33.24	160	32.0	25.0	20.0	4	30.70	101857	101858							
1 1/4	11	41.91	170	32.0	32.0	24.0	5	39.30	101850								
1 1/2	11	47.80	190	32.0	36.0	29.0	5	45.20	101849								

G DIN ISO 228 (BSP)



										N420-4	N420V-4	N420TN-4	
N420-4													
N420V-4	V												
N420TN-4	TiN												
\varnothing " d ₁ G	P TPI	d ₁ mm	l ₁ mm	l ₂ mm	d ₂ mm	a mm			\rightarrow \leftarrow	ID	ID	ID	
1/16	28	7.72	90	18.0	6.0	4.9	3	6.75		102045			
1/8	28	9.72	90	22.0	7.0	5.5	3	8.75		102048	102258	102236	
1/4	19	13.15	100	20.0	11.0	9.0	3	11.60		102047	102257	102235	
3/8	19	16.66	100	20.0	12.0	9.0	3	15.20		102053	102261	102238	
1/2	14	20.95	125	22.0	16.0	12.0	4	18.90		102046	102256	102234	
5/8	14	22.91	125	25.0	18.0	14.5	4	20.90		102054			
3/4	14	26.44	140	28.0	20.0	16.0	4	24.40		102052	102260	102237	
7/8	14	30.20	150	28.0	22.0	18.0	4	28.20		* 102055			
1	11	33.24	160	32.0	25.0	20.0	4	30.70		102049	102259		
1 1/4	11	41.91	170	32.0	32.0	24.0	5	39.30		102043			
1 1/2	11	47.80	190	32.0	36.0	29.0	5	45.20		102042			
2	11	59.61	220	36.0	45.0	35.0	5	57.00		102051			
2 1/2	11	75.18	280	36.0	50.0	39.0	6	72.60		102050			

G DIN ISO 228 (BSP)

HSSE



										N460-3	N460V-3	N460TN-3	N462V-3
N460-3													
N460V-3	V												
N460TN-3	TiN												
N462V-3	V												
$\varnothing'' d_1$ G	P TPI	d_1 mm	l_1 mm	l_2 mm	d_2 mm	α mm				ID	ID	ID	ID
1/16	28	7.72	90	12.5	6.0	4.9	3	6.75		102341			
1/8	28	9.72	90	14.0	7.0	5.5	3	8.75		102344	102457	102444	
1/4	19	13.15	100	14.0	11.0	9.0	3	11.60		102343	102456	102443	
3/8	19	16.66	100	14.0	12.0	9.0	4	15.20		102348	102460	102446	
1/2	14	20.95	125	20.0	16.0	12.0	4	18.90		102342	102455	102442	
5/8	14	22.91	125	20.0	18.0	14.5	4	20.90		102349			
3/4	14	26.44	140	22.0	20.0	16.0	4	24.40		102347	102459	102445	
7/8	14	30.20	150	24.0	22.0	18.0	4	28.20		* 102350			
1	11	33.24	160	26.0	25.0	20.0	4	30.70		102345	102458		
1 1/4	11	41.91	170	30.0	32.0	24.0	5	39.30		102340	111608		
1 1/2	11	47.80	190	35.0	36.0	29.0	5	45.20		102339	111609		
2	11	59.61	220	41.0	45.0	35.0	5	57.00		102346	111503		
$\varnothing'' d_1$ G	P TPI	d_1 mm	l_1 mm	l_2 mm	d_2 mm	α mm				ID			
1/8	28	9.72	90	14.0	7.0	5.5	3	8.75		143687			
1/4	19	13.15	100	14.0	11.0	9.0	3	11.60		143600			
3/8	19	16.66	100	14.0	12.0	9.0	4	15.20		143431			
1/2	14	20.95	125	20.0	16.0	12.0	4	18.90		143921			
3/4	14	26.44	140	22.0	20.0	16.0	4	24.40		143688			

G DIN ISO 228 (BSP)

PM HSSE
 ≤ Ø 25.4 > Ø 25.4

PM HSSE



										W460-5		H450-3	GG450NI-3
W460-5 													
H450-3 													
GG450NI-3 NI 													
Ø" d ₁	P	d ₁	l ₁	l ₂	d ₂	α				ID	ID		
G	TPI	mm	mm	mm	mm	mm							
1/8	28	9.72	90	14.0	7.0	5.5	3	8.75		119350	101298		
1/4	19	13.15	100	14.0	11.0	9.0	* 4	11.60		119300	101297		
3/8	19	16.66	100	14.0	12.0	9.0	4	15.20		119682	101301		
1/2	14	20.95	125	20.0	16.0	12.0	4	18.90		119199	101296		
3/4	14	26.44	140	22.0	20.0	16.0	4	24.40			101300		
1	11	33.24	160	26.0	25.0	20.0	4	30.70			101299		
* W460-5 = 3													
Ø" d ₁	P	d ₁	l ₁	l ₂	d ₂	α				ID			
G	TPI	mm	mm	mm	mm	mm							
1/8	28	9.72	90	22.0	7.0	5.5	4	8.75		102309			
1/4	19	13.15	100	20.0	11.0	9.0	4	11.60		102308			
3/8	19	16.66	100	20.0	12.0	9.0	4	15.20		102312			
1/2	14	20.95	125	22.0	16.0	12.0	4	18.90		102307			
3/4	14	26.44	140	28.0	20.0	16.0	4	24.40		102311			
1	11	33.24	160	32.0	25.0	20.0	4	30.70		102310			

G DIN ISO 228 (BSP)

< Ø 25.4 > Ø 25.4

PM **HSSE**
Z420 Z420

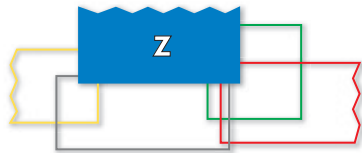

										Z420V-4	Z420VS-4	Z460V-3	Z460VS-3
<p>Z420V-4 V </p> <p>Z420VS-4 VS </p> <p>Z460V-3 V </p> <p>Z460VS-3 VS </p>													
Ø" d ₁ G	P TPI	d ₁ mm	l ₁ mm	l ₂ mm	d ₂ mm	α mm				ID	ID		
1/8	28	9.72	90	22.0	7.0	5.5	3	8.75		142794	142800		
1/4	19	13.15	100	20.0	11.0	9.0	3	11.60		142795	119303		
3/8	19	16.66	100	20.0	12.0	9.0	3	15.20		142796	142802		
1/2	14	20.95	125	22.0	16.0	12.0	4	18.90		142797	142803		
3/4	14	26.44	140	28.0	20.0	16.0	4	24.40		142798			
1	11	33.24	160	32.0	25.0	20.0	4	30.70		142799			
Ø" d ₁ G	P TPI	d ₁ mm	l ₁ mm	l ₂ mm	d ₂ mm	α mm					ID	ID	
1/8	28	9.72	90	14.0	7.0	5.5	3	8.75			104726	111577	
1/4	19	13.15	100	14.0	11.0	9.0	3	11.60			104725	111578	
3/8	19	16.66	100	14.0	12.0	9.0	4	15.20			104728	111579	
1/2	14	20.95	125	20.0	16.0	12.0	4	18.90			104724	111580	
3/4	14	26.44	140	22.0	20.0	16.0	4	24.40			104727		
1	11	33.24	160	26.0	25.0	20.0	4	30.70			105142		



Uniquement pour taraudage synchrone
 Nur für Synchronbearbeitung
 Only for rigid tapping
 Solo per maschiatura sincrona
 Solo para roscado sincronizado



RTS

Rigid Tapping Synchro

RTS462VS-3

RTS462VS-3



11	12	13	14
15	21	22	31
32	61	63	72
73	74		

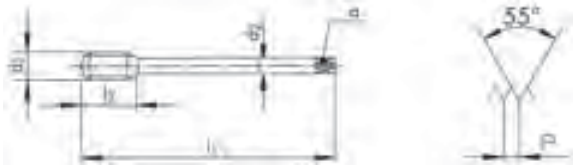

$\varnothing'' d_1$ G	P TPI	d_1 mm	l_1 mm	l_2 mm	$d_2 h6$ mm	a mm			ID
1/8	28	9.72	100	14.0	8.0	6.2	3	8.75	151861
1/4	19	13.15	110	14.0	12.0	9.0	3	11.60	151868
3/8	19	16.66	110	18.0	12.0	9.0	4	15.20	151872
1/2	14	20.95	125	20.0	16.0	12.0	4	18.90	150685



sur demande
 auf Anfrage
 on request
 su richiesta
 sobre pedido



264/265



FORMING

FP481VS-3 **VS**

11	12	13	14	15
21	24			

FA481VS-3 **VS**

12	13	14	15	21	22
23	24	41	51	61	63

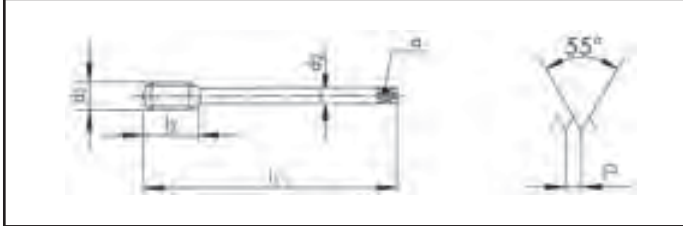



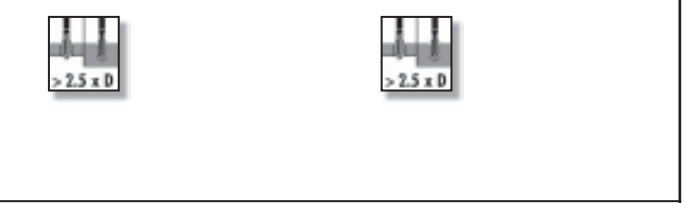







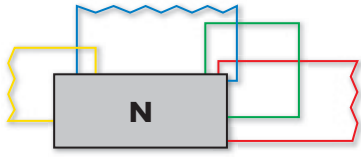

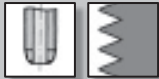
FP481VS-3		FA481VS-3	
-----------	--	-----------	--

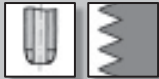

$\varnothing'' d_1$ G	P TPI	d_1 mm	l_1 mm	l_2 mm	d_2 mm	α mm	$\rightarrow \leftarrow$	Tol.
1/8	28	9.72	90	22.0	7.0	5.5	9.25	0.05
1/4	19	13.15	100	20.0	11.0	9.0	12.50	0.05
3/8	19	16.66	100	20.0	12.0	9.0	16.00	0.05
1/2	14	20.95	125	22.0	16.0	12.0	20.00	0.05

ID	ID
157302	157323
157303	157324
157304	157325
157305	157326





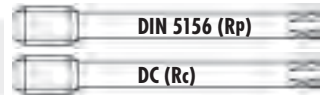

										N210-1	N210-3	N210-S
										  		
  												
												
\varnothing " d ₁	P	d ₁	l ₁	l ₂	d ₂	a				ID	ID	ID
G	TPI	mm	mm	mm	mm	mm						
1/16	28	7.72	63	18.0	6.0	4.9	3	6.75		101401	101418	119173
1/8	28	9.72	63	22.0	7.0	5.5	3	8.75		101404	101421	119386
1/4	19	13.15	70	20.0	11.0	9.0	3	11.60		101403	101420	119336
3/8	19	16.66	70	20.0	12.0	9.0	4	15.20		101409	101427	110938
1/2	14	20.95	80	22.0	16.0	12.0	4	18.90		101402	101419	119264
5/8	14	22.91	80	25.0	18.0	14.5	4	20.90		101411	105140	110940
3/4	14	26.44	90	28.0	20.0	16.0	4	24.40		101408	101426	110937
7/8	14	30.20	90	28.0	22.0	18.0	4	28.20		101412	101429	110941
1	11	33.24	100	32.0	25.0	20.0	4	30.70		101405	101422	110933
1 1/8	11	37.89	125	32.0	28.0	22.0	4	35.30			101415	
1 1/4	11	41.91	125	32.0	32.0	24.0	5	39.30		101400	101414	111425
1 3/8	11	44.32	125	32.0	36.0	29.0	5	41.80			101417	
1 1/2	11	47.80	140	32.0	36.0	29.0	5	45.20		101399	101413	110934
1 3/4	11	53.74	140	36.0	40.0	32.0	5	51.20			101416	
2	11	59.61	160	36.0	45.0	35.0	5	57.00		101407	101425	110935
2 1/4	11	65.71	160	36.0	50.0	39.0	6	63.10			101424	
2 1/2	11	75.18	160	36.0	50.0	39.0	6	72.60			101423	
3	11	87.88	160	40.0	50.0	39.0	6	85.30			101428	

Rp, Rc DIN EN 10226

HSSE

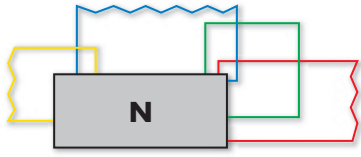

		N420-3		N410-3					
N420-3 									
N410-3 									
$\varnothing'' d_1$ Rp	P TPI	d_1 mm	l_1 mm	l_2 mm	d_2 mm	a mm			ID
1/8	28	9.72	90	22.0	7.0	5.5	3	8.60	104911
1/4	19	13.15	100	20.0	11.0	9.0	3	11.50	104912
3/8	19	16.66	100	20.0	12.0	9.0	3	15.00	104913
1/2	14	20.95	125	22.0	16.0	12.0	4	18.50	104914
3/4	14	26.44	140	28.0	20.0	16.0	4	24.00	104915
1	11	33.24	160	32.0	25.0	20.0	4	30.25	104916
$\varnothing'' d_1$ Rc	P TPI	d_1 mm	l_1 mm	l_2 mm	d_2 mm	a mm			ID
1/16	28	7.72	71	13.0	7.0	5.5	3		* 110984
1/8	28	9.72	71	13.0	8.0	6.2	5		104917
1/4	19	13.15	80	20.0	11.0	9.0	5		104918
3/8	19	16.66	90	20.0	12.0	9.0	5		104919
1/2	14	20.95	100	26.0	16.0	12.0	5		104920
3/4	14	26.44	110	26.0	20.0	16.0	5		104921
1	11	33.24	125	32.0	25.0	20.0	5		104922

					D5800			
D5800 								
								
\varnothing'' Rc	l_1 mm	l_2 mm	d_2 mm	a mm	ID			
1/16	70	17.0	6.0	4.9	118701			
1/8	70	17.0	8.0	6.2	110531			
1/4	80	27.0	10.0	8.0	110530			
3/8	85	27.0	12.0	9.0	110535			
1/2	95	35.0	16.0	12.0	110529			
3/4	105	35.0	20.0	16.0	110534			
1	130	43.0	25.0	20.0	110532			

Диаметр отверстия под коническую трубную резьбу по ISO 7/1 (BSPT)
Średnice otworów pod gwinty stożkowe rurowe wg ISO 7/1 (BSPT)

Отверстие с параллельными стенками
Повышенный износ, не рекомендуется

Отwór walcowy
Zwiększone zużycie gwintownika, nie zalecane

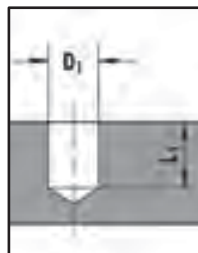

Коническое отверстие 1:16
Предварительное отв. D_2 и развёртывание до D_3

Отwór stożkowy 1:16
Nawierć na $\varnothing D_2$ i rozwić stożkowo na $\varnothing D_3$

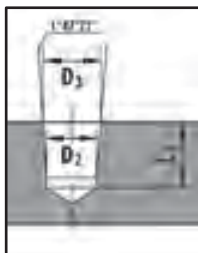

Коническое отверстие
Заход метчика на глубину $L_2 = \varnothing$ номинальный диаметр

Отwór gwintowany
Gwintuj otwór na głębokość $L_2 = \varnothing$ nominalna

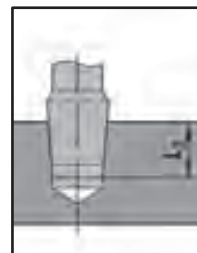











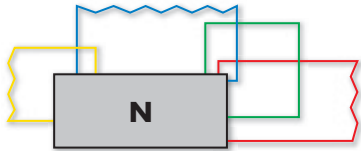



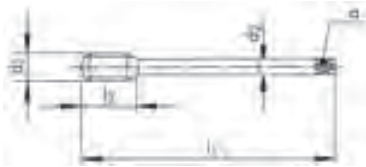

\varnothing'' Rc	L_1 min. mm	D_1 mm	D_2 mm	D_3 mm	L_2 mm
1/16	11.90	6.20	6.10	6.56	10.574
1/8	11.90	8.20	8.10	8.57	10.574
1/4	17.70	11.00	10.75	11.45	15.679
3/8	18.10	14.50	14.25	14.95	16.079
1/2	24.00	18.00	17.75	18.63	21.349
3/4	25.30	23.50	23.00	24.12	21.465
1	30.60	29.50	29.00	30.29	26.227

W BS 84 (BSW)

HSSE

















										N1110-1	N1110-2	N1110-3	N1120-4	
N1110-1														
N1110-2														
N1110-3			<div style="display: flex; justify-content: space-around;"> <div style="border: 1px solid black; padding: 2px;">31</div> <div style="border: 1px solid black; padding: 2px;">82</div> <div style="border: 1px solid black; padding: 2px;">74</div> </div>											
N1120-4			<div style="display: flex; justify-content: space-around;"> <div style="border: 1px solid black; padding: 2px;">61</div> <div style="border: 1px solid black; padding: 2px;">63</div> <div style="border: 1px solid black; padding: 2px;">71</div> <div style="border: 1px solid black; padding: 2px;">72</div> <div style="border: 1px solid black; padding: 2px;">73</div> </div> <div style="display: flex; justify-content: space-around; margin-top: 5px;"> <div style="border: 1px solid black; padding: 2px;">81</div> </div>											
\varnothing W	d_1	P	d_1	l_1	l_2	l_3	d_2	α			ID	ID	ID	ID
		TPI	mm	mm	mm	mm	mm	mm						
1/8	40	3.17	48	11.0	18	3.2	2.5	3	2.50	* 102825	* 102894	103025	103126	
5/32	32	3.96	53	13.0	21	4.0	3.2	3	3.10	* 102830	* 102898	103031	103130	
3/16	24	4.76	58	16.0	25	5.0	4.0	3	3.60	102826	102895	103026	103127	
1/4	20	6.35	66	19.0	30	6.3	5.0	3	4.90	102824	102893	103024	103125	
5/16	18	7.93	72	22.0	35	8.0	6.3	3	6.40	* 102829	* 102897	103030	103129	
3/8	16	9.52	80	24.0	39	10.0	8.0	3	7.70	102827	102896	103028	103128	

										N1210-1	N1210-2	N1210-3	N1220-4
										<p>N1210-1 </p> <p>N1210-2 </p> <p>N1210-3  31 82 74</p> <p>N1220-4  61 63 71 72 73 81</p>			
 													
													
$\frac{\text{Ø}''}{W}$ d_1	P	d_1	l_1	l_2	d_2	a			ϵ	ID	ID	ID	ID
7/16	14	11.11	85	22.0	8.0	6.3	3	9.10		* 103425	* 103476	103642	103771
1/2	12	12.70	89	24.0	9.0	7.1	3	10.30		103417	103471	103634	103767
9/16	12	14.28	95	24.0	11.2	9.0	3	11.90				103644	
5/8	11	15.87	102	32.0	12.5	10.0	3	13.30		103424	103475	103641	103770
3/4	10	19.05	112	33.0	14.0	11.2	3	16.20		103423	103474	103640	103769
1	8	25.40	130	45.0	18.0	14.0	4	21.90		103418	103472	103635	103768

NPT, NPTF

Указатель – Машинные метчики, NPT ANSI B1.20.1 и NPTF B1.20.3
 Skorowidz – Gwintowniki maszynowe, NPT ANSI B1.20.1 i NPTF B1.20.3

		N						
Характеристики Cechy charakterystyczne		 	 					
								
Типы отверстий Typ otworu								
								
	N410-3	N410V-3	N411V-3	D5800				
NPT Длинный по DIN NPT DIN długi DC	164	164	164	165				
NPTF Длинный по DIN NPTF DIN długi DC	164			165				

PG, TR

Указатель – Машинные и ручные метчики, PG DIN 40430, TR ISO 2901-2904, DIN 103
 Skorowidz – Gwintowniki maszynowe i ręczne, PG DIN 40430, TR ISO 2901-2904, DIN 103

	N						
Характеристики Cechy charakterystyczne							
Типы отверстий Typ otworu							
	N420-3	N410-1	N410-2	N410-3	N410-S	N410-8	
PG <i>Длинный по DIN</i> PG <i>DIN długi</i> DIN 40433	166						
TR <i>Длинный по DIN</i> TR <i>DIN długi</i> DC		167	167	167	167	166	
Класс точности Tolerancja TR 7H				167	167	166	

NPT, NPTF
PG, TR

NPT, NPTF

ANSI B1.20.1, ANSI B1.20.3

HSSE



							N410-3	N410V-3	N411V-3	N410-3
N410-3										
N410V-3										
N411V-3										
N410-3										
\varnothing d ₁ NPT, NPTF	P TPI	l ₁ mm	l ₂ mm	d ₂ mm	a mm		ID	ID	ID	ID
1/16	27	71	13.0	7.0	5.5	3	101961	102021	102031	101971
1/8	27	71	13.0	8.0	6.2	5	101964	102024	102034	101974
1/4	18	80	20.0	11.0	9.0	5	101963	102023	102033	101973
3/8	18	90	20.0	12.0	9.0	5	101968	102028	102038	101978
1/2	14	100	26.0	16.0	12.0	5	101962	102022	102032	101972
3/4	14	110	26.0	20.0	16.0	5	101967	102027	102037	101977
1	11.5	125	32.0	25.0	20.0	5	101965	102025	102035	101975
1 1/4	11.5	125	32.0	32.0	24.0	5	101960	102020		
1 1/2	11.5	140	32.0	36.0	29.0	5	101959	102019	* 102029	* 101969
2	11.5	160	32.0	36.0	29.0	7	101966	102026		* 101976

NPT, NPTF

ANSI B1.20.1, ANSI B1.20.3

HSSE

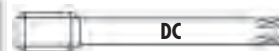

					D5800
D5800					
\varnothing'' NPT, NPTF	l_1 mm	l_2 mm	d_2 mm	α mm	ID
1/16	70	17.0	6.0	4.9	118701
1/8	70	17.0	8.0	6.2	110531
1/4	80	27.0	10.0	8.0	110530
3/8	85	27.0	12.0	9.0	110535
1/2	95	35.0	16.0	12.0	110529
3/4	105	35.0	20.0	16.0	110534
1	130	43.0	25.0	20.0	110532

Диаметр отверстия под резьбы NPT и NPTF Średnice otworów pod gwinty NPT oraz NPTF

Отверстие с параллельными стенками
Повышенный износ, не рекомендуется

Отwór walcowy
Zwiększone zużycie gwintownika, nie zalecane

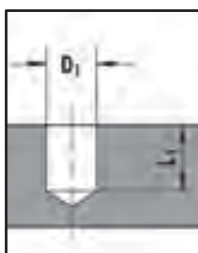

Коническое отверстие 1:16
Предварительное отв. D_1 и развертывание до D_2

Отwór stożkowy 1:16
Nawierc na $\varnothing D_1$ i rozwiерc stożkowo na $\varnothing D_2$

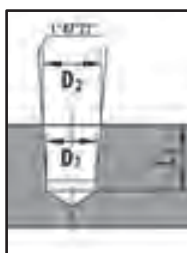

Коническое отверстие
Заход метчика на глубину $L_2 = \varnothing$ номинальный диаметр

Отwór gwintowany
Gwintuj otwór na głębokość $L_2 = \varnothing$ nominalna

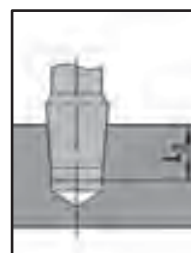

*Рекомендуется конич. развертывание до D_2

*Zalecane jest rozwiercanie stożkowe do górnego limitu D_2

\varnothing'' NPT, NPTF	L_1 min. mm	D_1 mm	* D_2 mini mm	* D_2 maxi mm	L_2 mm
1/16	11.40	6.00	6.413	6.505	10.179
1/8	11.65	8.30	8.760	8.852	10.217
1/4	16.85	10.80	11.397	11.483	14.958
3/8	17.20	14.20	14.836	14.922	15.268
1/2	22.25	17.50	18.333	18.419	19.920
3/4	22.70	22.80	23.678	23.764	20.403
1	27.20	28.65	29.726	29.812	24.518

NPT, NPTF

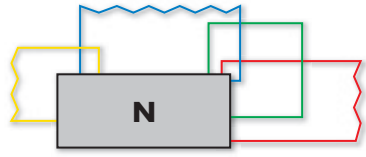
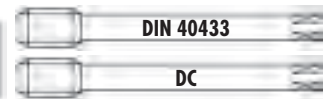

PG DIN 40430 TR ISO 2901-2904, DIN 103

HSSE



N420-3			N410-8
--------	--	--	--------

N420-3



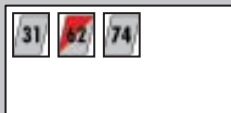
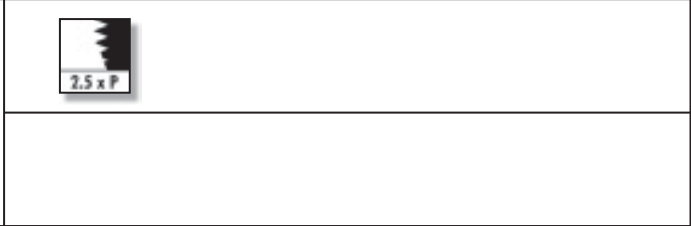
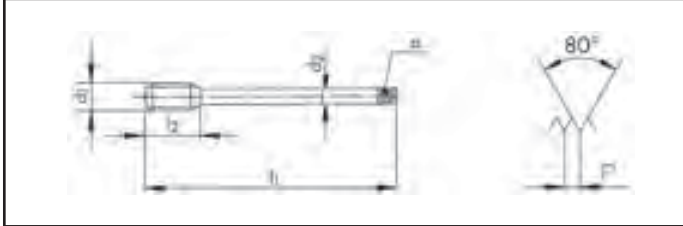

N410-8





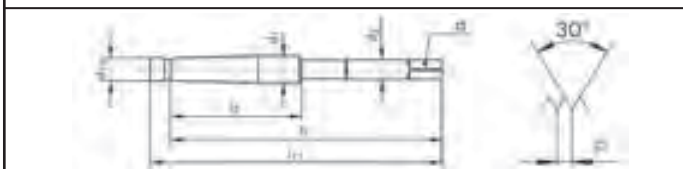





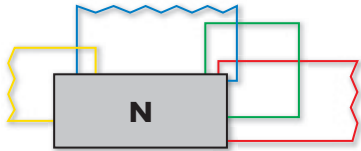

$\varnothing d_1$ PG	P TPI	d_1 mm	l_1 mm	l_2 mm	d_2 mm	α mm			ID
7	20	12.50	100	24.0	9.0	7.0	3	11.30	104901
9	18	15.20	100	26.0	12.0	9.0	3	13.90	104902
11	18	18.60	110	26.0	14.0	11.0	4	17.30	104903
13.50	18	20.40	125	28.0	16.0	12.0	4	19.10	104904
16	18	22.50	125	28.0	18.0	14.5	4	21.20	104905
21	16	28.30	150	36.0	22.0	18.0	4	26.80	104906
29	16	37.00	170	38.0	28.0	22.0	4	35.50	104907
36	16	47.00	190	38.0	36.0	29.0	5	45.50	104908
48	16	59.30	220	42.0	45.0	35.0	5	57.80	* 104910







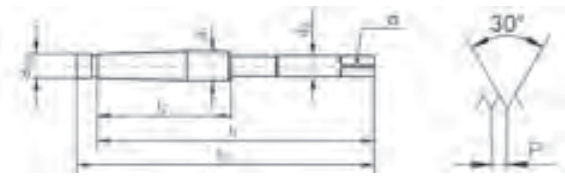













		2.5 x P	
--	--	---------	--



$\varnothing d_1$ TR	P mm	l_{11} mm	l_2 mm	d_{10} mm	d_2 mm	α mm			ID
10	2.00	93	45.0	8.20	7.0	5.5	3	8.20	102008
12	3.00	129	75.0	9.25	8.0	6.2	3	9.25	102009
14	3.00	139	75.0	11.25	10.0	8.0	3	11.25	102010
16	4.00	165	100.0	12.25	11.0	9.0	3	12.25	102011
18	4.00	165	100.0	14.25	12.0	9.0	3	14.25	102012
20	4.00	175	100.0	16.25	14.0	11.0	3	16.25	102013
22	5.00	201	110.0	17.25	16.0	12.0	4	17.25	111616
24	5.00	201	110.0	19.25	18.0	14.5	4	19.25	102015













									7H
--	--	--	--	--	--	--	--	--	----

									N410-1	N410-2	N410-3	N410-S
												
N410-1												
N410-2												
N410-3												
N410-S												
									<div style="display: flex; justify-content: space-around;"> <div style="border: 1px solid black; padding: 5px;">7H</div> <div style="border: 1px solid black; padding: 5px;">7H</div> </div>			
$\varnothing d_1$ TR	P mm	l_{11} mm	l_2 mm	d_{10} mm	d_2 mm	a mm			ID	ID	ID	ID
10	2.00	78	30.0	8.20	7.0	5.5	3	8.20	101827	101838	101979	110972
12	3.00	104	45.0	9.25	8.0	6.2	3	9.25	101828	101839	101980	110973
16	4.00	150	65.0	12.25	11.0	9.0	3	12.25	101830	101841	101982	110975
18	4.00	150	65.0	14.25	12.0	9.0	3	14.25	* 101831	* 101842	* 101983	* 110976
20	4.00	160	65.0	16.25	14.0	11.0	3	16.25	101832	101843	101984	110977
22	5.00	186	75.0	17.25	16.0	12.0	4	17.25	* 101833	* 101844	* 102014	* 110978

	N				S		SA
Характеристики Cechy charakterystyczne 		 	 R40	 R40 	 	 R35 	
Типы отверстий Typ otworu 							
	N320-4	N320V-4	N360-3	N360V-3	S320VS-4	S360VS-3	SA320-4
Длинный по DIN DIN długi ~DIN 40435	170	170	171	171			172
Длинный по DIN DIN długi ~DIN 2184-1	174/176		174/176		177	177	175/178
Резьба Gwint EG M	170	170	171	171			172
Резьба Gwint EG UNC	174		174				175
Резьба Gwint EG UNF	176		176		177	177	178
	N420-4	N420V-4	N460-3	N460V-3			
Длинный по DIN DIN długi ~DIN 40435	170	170	171	171			
Длинный по DIN DIN długi ~DIN 2184-1	174/176		174/176				
Резьба Gwint EG M	170	170	171	171			
Резьба Gwint EG UNC	174		174				
Резьба Gwint EG UNF	176		176				

EG

Указатель – Машинные метчики для резьбовых вставок, EG M, EG UNC, EG UNF
 Skorowidz – Gwintowniki maszynowe pod wkładki HELICOIL, EG M, EG UNC, EG UNF

SA		TL	
			
		VS	VS
			
			
SA350-3	SA390-3	TL320VS-4	TL351VS-3
172	173	172	172
175/178	177	175/178	175/178
172	173	172	172
175		175	175
178	177	178	178

THREADING
TECHNOLOGY



www.dcswiss.com

EG M, EG UN



≤ Ø 2.8 > Ø 2.8

PM

HSSE



										N320-4	N320V-4	N420-4	N420V-4
N320-4													
N320V-4	V												
N420-4													
N420V-4	V												
Ø d ₁ EG M	P mm	d ₂ mm	l ₁ mm	l ₂ mm	l ₃ mm	d ₂ mm	a mm			ID	ID	ID	ID
2	0.40	2.520	50	10.0		2.8	2.1	3	2.10	101537			
2.5	0.45	3.084	56	12.0	18	3.5	2.7	3	2.65	101538			
3	0.50	3.650	56	13.0	20	4.0	3.0	3	3.15	101539	142804		
4	0.70	4.910	70	15.0	25	6.0	4.9	3	4.20	101540	142805		
5	0.80	6.040	80	17.0	30	6.0	4.9	3	5.25	101541	142806		
6	1.00	7.300	80	17.0	30	7.0	5.5	3	6.30	101542	142807		
8	1.25	9.624	100	22.0	39	10.0	8.0	3	8.40	101543	142808		
10	1.50	11.948	100	24.0		9.0	7.0	3	10.40			102252	142809
12	1.75	14.274	110	28.0		11.0	9.0	3	12.50			102253	142810
14	2.00	16.598	110	30.0		12.0	9.0	3	14.60			110987	142811
16	2.00	18.598	125	33.0		14.0	11.0	3	16.60			102255	142812

EG M ISO DIN 8140



≤ Ø 2.8 > Ø 2.8

PM

HSSE



										N360-3	N360V-3	N460-3	N460V-3
N360-3													
N360V-3	V												
N460-3													
N460V-3	V												
Ø d ₁ EG M	P mm	d ₂ mm	l ₁ mm	l ₂ mm	l ₃ mm	d ₂ mm	a mm			ID	ID	ID	ID
2	0.40	2.520	50	9.0		2.8	2.1	2	2.10	101599			
2.5	0.45	3.084	56	5.5	18	3.5	2.7	3	2.65	101600			
3	0.50	3.650	56	6.5	20	4.0	3.0	3	3.15	101601	142813		
4	0.70	4.910	70	9.0	25	6.0	4.9	3	4.20	101602	142814		
5	0.80	6.040	80	11.0	30	6.0	4.9	3	5.25	101603	142815		
6	1.00	7.300	80	11.0	30	7.0	5.5	3	6.30	101604	142816		
8	1.25	9.624	100	14.0	39	10.0	8.0	3	8.40	101605	142817		
10	1.50	11.948	100	14.0		9.0	7.0	3	10.40			102335	142818
12	1.75	14.274	110	14.0		11.0	9.0	3	12.50			102336	142819
14	2.00	16.598	110	18.0		12.0	9.0	3	14.60			102337	142820
16	2.00	18.598	125	21.0		14.0	11.0	3	16.60			102338	142821



AERO

										SA320-4	SA350-3	TL320VS-4	TL351VS-3																																																																																										
<div style="display: flex; justify-content: space-between;"> <div style="width: 45%;"> <p>SA320-4 52 53</p> <p>SA350-3 52 53</p> </div> <div style="width: 50%; text-align: center;"> </div> </div>										<div style="display: flex; justify-content: space-around; margin-top: 10px;"> </div>																																																																																													
<div style="display: flex; justify-content: space-between;"> <div style="width: 45%;"> <p>TL320VS-4 VS 41 42</p> <p>TL351VS-3 VS 41 42</p> </div> <div style="width: 50%; text-align: center;"> </div> </div>										<div style="display: flex; justify-content: space-around; margin-top: 10px;"> </div>																																																																																													
										<div style="display: flex; justify-content: space-around; margin-top: 10px;"> </div>																																																																																													
										<div style="display: flex; justify-content: space-around; margin-top: 10px;"> </div>																																																																																													
<table border="1" style="width: 100%; border-collapse: collapse; font-size: small;"> <thead> <tr> <th>$\varnothing d_1$ EG M</th> <th>P mm</th> <th>d_1 mm</th> <th>l_1 mm</th> <th>l_2 mm</th> <th>l_3 mm</th> <th>d_2 mm</th> <th>α mm</th> <th></th> <th></th> </tr> </thead> <tbody> <tr><td>3</td><td>0.50</td><td>3.650</td><td>56</td><td>13.0</td><td></td><td>4.0</td><td>3.0</td><td>3</td><td>3.15</td></tr> <tr><td>4</td><td>0.70</td><td>4.910</td><td>70</td><td>15.0</td><td></td><td>6.0</td><td>4.9</td><td>3</td><td>4.20</td></tr> <tr><td>5</td><td>0.80</td><td>6.040</td><td>80</td><td>15.0</td><td>23</td><td>6.0</td><td>4.9</td><td>3</td><td>5.25</td></tr> <tr><td>6</td><td>1.00</td><td>7.300</td><td>80</td><td>15.0</td><td>23</td><td>7.0</td><td>5.5</td><td>3</td><td>6.30</td></tr> <tr><td>8</td><td>1.25</td><td>9.624</td><td>100</td><td>20.0</td><td>33</td><td>10.0</td><td>8.0</td><td>3</td><td>8.40</td></tr> </tbody> </table>										$\varnothing d_1$ EG M	P mm	d_1 mm	l_1 mm	l_2 mm	l_3 mm	d_2 mm	α mm			3	0.50	3.650	56	13.0		4.0	3.0	3	3.15	4	0.70	4.910	70	15.0		6.0	4.9	3	4.20	5	0.80	6.040	80	15.0	23	6.0	4.9	3	5.25	6	1.00	7.300	80	15.0	23	7.0	5.5	3	6.30	8	1.25	9.624	100	20.0	33	10.0	8.0	3	8.40	<table border="1" style="width: 100%; border-collapse: collapse; font-size: small;"> <thead> <tr> <th>ID</th> <th>ID</th> <th>ID</th> <th>ID</th> </tr> </thead> <tbody> <tr><td>147676</td><td>147682</td><td>152001</td><td>150478</td></tr> <tr><td>147678</td><td>147684</td><td>152002</td><td>152003</td></tr> <tr><td>147680</td><td>147686</td><td>147808</td><td>150184</td></tr> <tr><td>147688</td><td>147692</td><td>152004</td><td>152005</td></tr> <tr><td>149354</td><td>149356</td><td>152088</td><td>152089</td></tr> </tbody> </table>										ID	ID	ID	ID	147676	147682	152001	150478	147678	147684	152002	152003	147680	147686	147808	150184	147688	147692	152004	152005	149354	149356	152088	152089
$\varnothing d_1$ EG M	P mm	d_1 mm	l_1 mm	l_2 mm	l_3 mm	d_2 mm	α mm																																																																																																
3	0.50	3.650	56	13.0		4.0	3.0	3	3.15																																																																																														
4	0.70	4.910	70	15.0		6.0	4.9	3	4.20																																																																																														
5	0.80	6.040	80	15.0	23	6.0	4.9	3	5.25																																																																																														
6	1.00	7.300	80	15.0	23	7.0	5.5	3	6.30																																																																																														
8	1.25	9.624	100	20.0	33	10.0	8.0	3	8.40																																																																																														
ID	ID	ID	ID																																																																																																				
147676	147682	152001	150478																																																																																																				
147678	147684	152002	152003																																																																																																				
147680	147686	147808	150184																																																																																																				
147688	147692	152004	152005																																																																																																				
149354	149356	152088	152089																																																																																																				



AERO

SA390-3

SA390-3



∅ d ₁ EG M	P mm	d ₁ mm	l ₁ mm	l ₂ mm	d ₂ mm	α mm			ID
3	0.50	3.650	56	13.0	4.0	3.0	3	3.15	149669
4	0.70	4.910	70	15.0	6.0	4.9	3	4.20	149688
5	0.80	6.040	80	20.0	6.0	4.9	3	5.25	149710
6	1.00	7.300	80	20.0	7.0	5.5	3	6.30	149723
8	1.25	9.624	100	30.0	10.0	8.0	3	8.40	149748
10	1.50	11.948	110	35.0	12.0	9.0	3	10.40	149767

EG UNC NASM33537



≤ Ø 2.8 > Ø 2.8

PM

HSSE

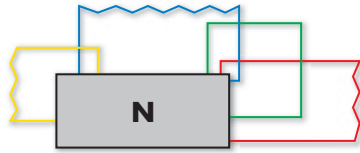

N320-4 N420-4 N360-3 N460-3

N320-4



N420-4



N360-3



N460-3

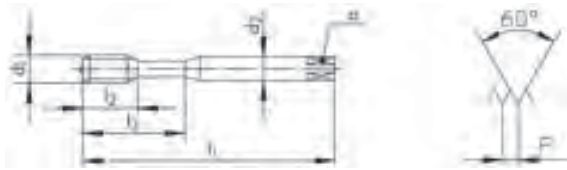

3B

3B

3B

3B

Ø" d ₁ EG UNC	P TPI	d ₁ mm	l ₁ mm	l ₂ mm	l ₃ mm	d ₂ mm	α mm		
4	40	3.67	56	13.0	20	4.0	3.0	3	3.05
6	32	4.53	70	15.0	25	6.0	4.9	3	3.75
8	32	5.19	70	15.0	25	6.0	4.9	3	4.45
10	24	6.20	80	17.0	30	7.0	5.5	3	5.10
1/4	20	8.00	90	20.0	35	8.0	6.2	3	6.70
5/16	18	9.77	100	22.0	39	10.0	8.0	3	8.40
3/8	16	11.59	110	24.0		9.0	7.0	3	10.00
1/2	13	15.23	110	30.0		12.0	9.0	3	13.30

ID	ID
110946	
110948	
110949	
110945	
110944	
110947	
	110033
	104935

Ø" d ₁ EG UNC	P TPI	d ₁ mm	l ₁ mm	l ₂ mm	l ₃ mm	d ₂ mm	α mm		
4	40	3.67	56	6.5	20	4.0	3.0	3	3.05
6	32	4.53	70	9.0	25	6.0	4.9	3	3.75
8	32	5.19	70	9.0	25	6.0	4.9	3	4.45
10	24	6.20	80	11.0	30	7.0	5.5	3	5.10
1/4	20	8.00	90	12.5	35	8.0	6.2	3	6.70
5/16	18	9.77	100	14.0	39	10.0	8.0	3	8.40
3/8	16	11.58	110	14.0		9.0	7.0	3	10.00
1/2	13	15.23	110	18.0		12.0	9.0	3	13.30

ID	ID	
	110018	
	110019	
	110956	
	110954	
	110024	
	111759	
		111715
		111558



AERO

SA320-4

SA350-3

TL320VS-4

TL351VS-3

SA320-4



52 53

SA350-3



52 53

TL320VS-4



VS

41 42

TL351VS-3



VS

41 42



Ø" d ₁ EG UNC	P TPI	d ₁ mm	l ₁ mm	l ₂ mm	l ₃ mm	d ₂ mm	a mm		
4	40	3.67	56	13.0		4.0	3.0	3	3.05
6	32	4.53	70	15.0		6.0	4.9	3	3.75
8	32	5.19	70	15.0		6.0	4.9	3	4.45
1/4	20	8.00	90	18.0	29	8.0	6.2	3	6.70
5/16	18	9.77	100	20.0	33	10.0	8.0	3	8.40

ID

ID

ID

ID

149073

149075

152030

152031

149121

149123

152040

152041

149170

149172

152052

152053

149284

149286

152073

152074

149358

149360

152090

152091

EG UNF NASM33537



≤ Ø 2.8 > Ø 2.8

PM **HSSE**

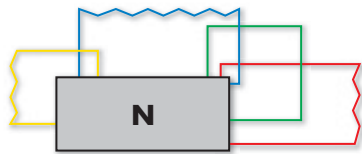

N320-4	N420-4	N360-3	N460-3
--------	--------	--------	--------

N320-4		
N420-4		
N360-3		
N460-3		

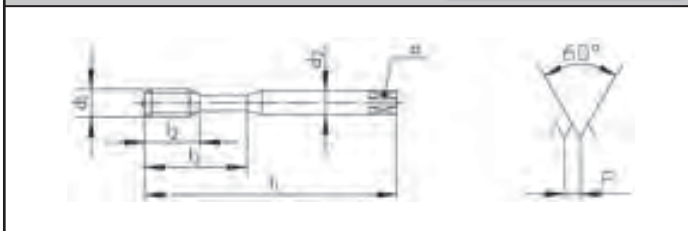

3B	3B	3B	3B

Ø" d ₁ EG UNF	P TPI	d ₁ mm	l ₁ mm	l ₂ mm	l ₃ mm	d ₂ mm	α mm		
6	40	4.33	63	14.0	21	4.5	3.4	3	3.70
8	36	5.08	70	15.0	25	6.0	4.9	3	4.40
10	32	5.85	80	17.0	30	6.0	4.9	3	5.10
1/4	28	7.52	90	20.0	35	8.0	6.2	3	6.65
5/16	24	9.31	90	20.0	35	9.0	7.0	3	8.20
3/8	24	10.89	100	19.0		8.0	6.2	3	9.80
1/2	20	14.35	100	24.0		11.0	9.0	3	13.10

ID	ID
118879	
118882	
104941	
110234	
118876	
	118873
	118865

Ø" d ₁ EG UNF	P TPI	d ₁ mm	l ₁ mm	l ₂ mm	l ₃ mm	d ₂ mm	α mm		
6	40	4.33	63	7.5	21	4.5	3.4	3	3.70
8	36	5.08	70	9.0	25	6.0	4.9	3	4.40
10	32	5.85	80	11.0	30	6.0	4.9	3	5.10
1/4	28	7.52	90	12.5	35	8.0	6.2	3	6.65
5/16	24	9.31	90	12.5	35	9.0	7.0	3	8.20
3/8	24	10.89	100	19.0		8.0	6.2	3	9.80
1/2	20	14.35	100	14.0		11.0	9.0	3	13.10

ID	ID
	110959
	110960
	104946
	110020
	111619
	110027
	104951



PM

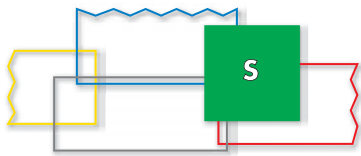

S320VS-4

S360VS-3

SA390-3



S320VS-4



VS

13	15	24	52
----	----	----	----

S360VS-3



VS

13	15	24	52
----	----	----	----

AERO

SA390-3



53



3B

3B

3B

Ø" d ₁ EG UNF	P TPI	d ₁ mm	l ₁ mm	l ₂ mm	l ₃ mm	d ₂ mm	α mm			→ €	ID
10	32	5.85	80	17.0	30	6.0	4.9	3	5.10		111821
1/4	28	7.52	90	20.0	35	8.0	6.2	3	6.65		111822
5/16	24	9.31	90	20.0	35	9.0	7.0	3	8.20		111823

Ø" d ₁ EG UNF	P TPI	d ₁ mm	l ₁ mm	l ₂ mm	l ₃ mm	d ₂ mm	α mm			→ €	ID
10	32	5.85	80	11.0	30	6.0	4.9	3	5.10		111811
1/4	28	7.52	90	12.5	35	8.0	6.2	3	6.65		111812
5/16	24	9.31	90	12.5	35	9.0	7.0	3	8.20		111824

Ø" d ₁ EG UNF	P TPI	d ₁ mm	l ₁ mm	l ₂ mm	d ₂ mm	α mm			→ €	ID
10	32	5.85	80	20.0	6.0	4.9	3	5.10		149702
1/4	28	7.52	90	25.0	8.0	6.2	3	6.65		149724



AERO

SA320-4

SA350-3

TL320VS-4

TL351VS-3



SA320-4



52 53

SA350-3



52 53

TL320VS-4



VS

41 42

TL351VS-3



VS

41 42

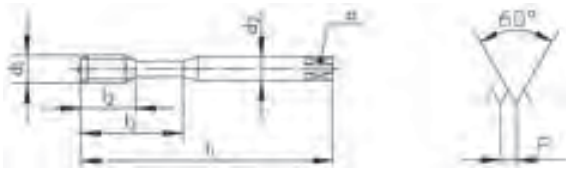

Ø" d ₁ EG UNF	P TPI	d ₁ mm	l ₁ mm	l ₂ mm	l ₃ mm	d ₂ mm	a mm		
10	32	5.85	80	15.0	23	6.0	4.9	3	5.10
1/4	28	7.52	90	18.0	29	8.0	6.2	3	6.65
5/16	24	9.31	90	20.0	31	9.0	7.0	3	8.20

ID

ID

ID

ID

149190

149192

148009

148008

146099

149268

148015

148014

149336

149338

148022

148021

Общая информация

Корончатый метчик DC с рабочей поверхностью, „V”-обработанной для предотвращения холодной сварки, является высокопроизводительным инструментом, обеспечивающим высокое качество поверхности нарезаемой резьбы.

Сфера применения

Благодаря внутренней емкости для стружкоотвода во фронтальной части, корончатые метчики DC могут быть использованы для нарезания резьбы как в сквозных, так и в глухих отверстиях. Корончатый метчик может быть использован для материалов с пределом прочности до 850Н/мм² и коэффициентом удлинения максимум 30%

Использование

Корончатый метчик может быть использован для сквозных отверстий любой глубины. Однако, для оптимального нарезания в глухих отверстиях, отверстие под резьбу должно быть соответствующим и следующие инструкции должны выполняться:

- Нарезайте резьбу до срабатывания предохранительной муфты патрона
- Выверните метчик и очистите от стружки
- Нарезайте резьбу на полную глубину

Общие указания

Эффективная работа корончатых метчиков DC, также как и качество нарезаемой резьбы, зависят от соблюдения следующих правил:

- Не превышайте максимально допустимую погрешность центрирования инструмента в 0.1мм
- Метчик должен двигаться соосно отверстию, используйте резьбонарезной патрон
- Нарезайте резьбу с рекомендованной скоростью
- Выбирайте СОЖ в зависимости от материала, в котором будет нарезаться резьба
- Используйте патрон с осевой компенсацией и предохранительной муфтой
- Отрегулируйте предохранительную муфту таким образом, чтобы она срабатывала при достижении

Когда нарезаете первую резьбу, ослабьте предохранительную муфту до проскальзывания, затем постепенно затяните, пока метчик не начнет вращаться.

Сбор стружки

Объем стружкоотводящей емкости рассчитан на следующую глубину:

Диаметр резьбы	Ø 20 - 29 mm	≥ Ø 30 mm
M	-	1.4 x D
MF	1.2 x D	1.4 x D
UN-8	-	1.4 x D
G	1.2 x D	1.4 x D

Скорости резания и обороты шпинделя (рекомендованные) – Zalecane parametry skrawania

M				P				MF				UN-8			
M	P	V _c (m/min)	n (U/min)	MF	P	V _c (m/min)	n (U/min)	MF	P	V _c (m/min)	n (U/min)	UN-8	P TPI	V _c (m/min)	n (U/min)
30	3.5	7.9	84	22	1.5	8.0	116	45	1.5	6.9	49	1 1/4"	8.0	7.8	77
33	3.5	7.7	74	24	1.5	8.0	106	45	2.0	6.9	49	1 3/8"	8.0	7.6	69
36	4.0	7.5	66	26	1.5	7.9	97	48	1.5	6.6	44	1 1/2"	8.0	7.3	62
39	4.0	7.3	60	28	1.5	7.9	90	48	2.0	6.6	44	1 5/8"	8.0	7.1	55
42	4.5	7.1	54	30	1.5	7.9	84	48	3.0	6.6	44	1 3/4"	8.0	6.9	49
45	4.5	6.9	49	30	2.0	7.9	84	48	4.0	6.6	44	1 7/8"	8.0	6.7	45
48	5.0	6.6	44	32	1.5	7.8	77	50	1.5	6.5	41	2"	8.0	6.4	40
52	5.0	6.4	39	32	2.0	7.8	77	52	1.5	6.4	39				
56	5.5	6.1	35	33	1.5	7.7	74	52	3.0	6.4	39				
60	5.5	5.8	31	33	2.0	7.7	74	55	1.5	6.2	36				
64	6.0	5.5	28	34	1.5	7.6	71	56	4.0	6.1	35				
68	6.0	5.2	25	35	1.5	7.6	69	60	2.0	5.8	31				
				36	1.5	7.5	66	64	4.0	5.5	28				
				36	2.0	7.5	66	68	4.0	5.2	25				
				36	3.0	7.5	66	72	6.0	5.0	22				
				38	1.5	7.3	62	76	6.0	4.7	20				
				40	1.5	7.2	57	80	2.0	4.4	18				
				40	2.0	7.2	57	80	4.0	4.4	18				
				42	1.5	7.1	54	80	6.0	4.4	18				
				42	2.0	7.1	54	90	6.0	3.7	13				
				42	3.0	7.1	54	100	6.0	3.0	10				
				42	4.0	7.1	54	110	6.0	2.5	7				

Informacje ogólne

Waporyzowany („V”) gwintownik koronowy jest narzędziem o dużej wydajności, które oferuje bardzo dobrą jakość powierzchni wykonywanego gwintu. „V”- obróbka powierzchniowa zapobiegająca powstawaniu narostu.

Zastosowanie

Dzięki wybraniu od frontu zapewniającemu miejsce na gromadzenie wióra, gwintownik koronowy DC jest odpowiedni do gwintowania zarówno otworów przelotowych jak i nieprzelotowych. Gwintownik koronowy może być użyty w materiałach o wytrzymałości na rozciąganie do 850 N/mm² i o maksymalnym wydłużeniu 30 %.

Wykorzystanie

Gwintownik koronowy może być użyty do otworów przelotowych każdej głębokości. Jednakże do optymalnego gwintowania otworów nieprzelotowych, głębokość otworu pod gwint musi być odpowiednio dostosowana i powinny zostać spełnione poniższe warunki:

- Gwintuj do momentu zadziałania sprzęgła w oprawce
- Wycofaj gwintownik i usuń wióry
- Gwintuj na pełną głębokość

Ogólne wskazówki

Wydajna praca gwintownikami koronowymi DC, jak również jakość wykonywanych gwintów zależy od poniższych zasad:

- Nie przekraczaj maksymalnego dopuszczalnego błędu centrozwania, 0.1 mm
- Gwintownik musi pracować współosiowo, używaj odpowiedniej oprawki
- Gwintuj z odpowiednią prędkością skrawania
- Wybierz odpowiednie chłodziwo do materiału, który będzie gwintowany
- Użyj oprawki z kompensacją osiową i sprzęgłem przeciążeniowym
- Ustaw sprzęgło przeciążeniowe tak, aby zadziałało tuż powyżej przewidywanej wartości momentu obrotowego.

Kiedy gwintujesz pierwszy otwór, poluzuj sprzęgło aż do uzyskania poślizgu, następnie stopniowo dokręć je do momentu, aż gwintownik zacznie się obracać.

Gromadzenie wióra

Pojemność wybrania na gromadzenie wióra jest następująca:

Srednica gwintu	Ø 20 - 29 mm	≥ Ø 30 mm
M	-	1.4 x D
MF	1.2 x D	1.4 x D
UN-8	-	1.4 x D
G	1.2 x D	1.4 x D

M, MF ISO DIN 13

HSSE



		N470V-4		N470V-3				
N470V-4								
N470V-3								
$\varnothing d_1$ M	P mm	l_1 mm	l_2 mm	d_2 mm	a mm			ID
30	3.50	180	39.0	22.0	18.0	5	26.50	102575
33	3.50	180	39.0	22.0	18.0	5	29.50	102576
36	4.00	200	43.0	25.0	20.0	5	32.00	102577
39	4.00	200	43.0	25.0	20.0	5	35.00	102578
42	4.50	220	47.0	28.0	22.0	5	37.50	102579
45	4.50	220	47.0	28.0	22.0	5	40.50	102580
48	5.00	240	52.0	32.0	24.0	5	43.00	102581
52	5.00	240	52.0	32.0	24.0	5	47.00	102582
56	5.50	260	58.0	36.0	29.0	6	50.50	102583
60	5.50	260	58.0	36.0	29.0	6	54.50	102584
64	6.00	290	64.0	40.0	32.0	6	58.00	102585
68	6.00	290	64.0	40.0	32.0	6	62.00	* 102586
$\varnothing d_1$ MF	P mm	l_1 mm	l_2 mm	d_2 mm	a mm			ID
Δ 22	1.50	125	28.0	18.0	14.5	4	20.50	* 102526
Δ 24	1.50	140	30.0	18.0	14.5	4	22.50	* 102527
Δ 26	1.50	140	30.0	18.0	14.5	4	24.50	* 102529
Δ 28	1.50	140	30.0	20.0	16.0	4	26.50	* 102530
30	1.50	160	32.0	22.0	18.0	5	28.50	102531
30	2.00	160	32.0	22.0	18.0	5	28.00	102532
32	1.50	160	32.0	22.0	18.0	5	30.50	* 102533
33	1.50	160	32.0	22.0	18.0	5	31.50	* 102535
33	2.00	160	32.0	22.0	18.0	5	31.00	* 102536
34	1.50	160	26.0	22.0	18.0	5	32.50	* 102537
35	1.50	175	28.0	25.0	20.0	5	33.50	* 102538
36	1.50	175	28.0	25.0	20.0	5	34.50	* 102539
36	2.00	175	35.0	25.0	20.0	5	34.00	102540
36	3.00	200	43.0	25.0	20.0	5	33.00	102541

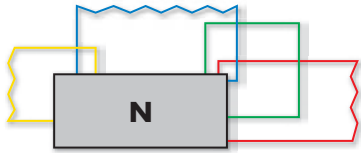

N470V-3

N470V-4

N470V-3



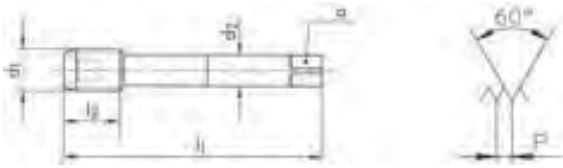

N470V-4





ISO 2
6H

ISO 2
6H

∅ d ₁ MF	P mm	l ₁ mm	l ₂ mm	d ₂ mm	a mm			→ ←
38	1.50	175	28.0	25.0	20.0	5	36.50	
40	1.50	190	31.0	28.0	22.0	5	38.50	
40	2.00	190	38.0	28.0	22.0	5	38.00	
42	1.50	190	31.0	28.0	22.0	5	40.50	
42	2.00	190	38.0	28.0	22.0	5	40.00	
42	3.00	220	47.0	28.0	22.0	5	39.00	
45	1.50	190	31.0	28.0	22.0	5	43.50	
48	1.50	205	34.0	32.0	24.0	5	46.50	
48	3.00	205	41.0	32.0	24.0	5	45.00	
52	1.50	205	34.0	32.0	24.0	5	50.50	
52	3.00	205	41.0	32.0	24.0	5	49.00	
56	4.00	260	58.0	36.0	29.0	6	52.00	
60	2.00	220	37.0	36.0	29.0	6	58.00	
64	4.00	290	64.0	40.0	32.0	6	60.00	
68	4.00	290	64.0	40.0	32.0	6	64.00	
80	4.00	270	56.0	45.0	35.0	7	76.00	

ID

* 102542
* 102543
* 102544
* 102545
102546
102547
* 102549
* 102551
102553
* 102556
102557
102559
* 102560
102561
* 102562
* 102564

∅ d ₁ MF	P mm	l ₁ mm	l ₂ mm	d ₂ mm	a mm			→ ←
76	6.00	290	64.0	40.0	32.0	7	70.00	
80	6.00	320	71.0	45.0	35.0	7	74.00	
110	6.00	350	79.0	50.0	39.0	8	104.00	

ID

* 111000
* 110012
* 110004

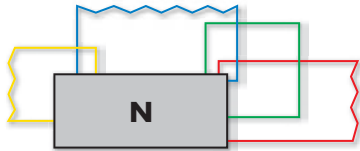



N470V-3

N470V-3

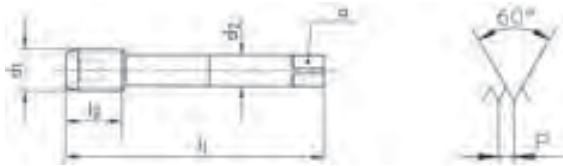

2B



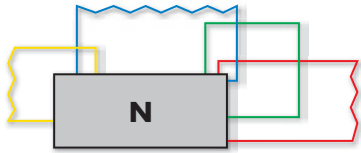

Ø" d ₁ UN	P TPI	d ₁ mm	l ₁ mm	l ₂ mm	d ₂ mm	α mm			ID
1 1/4	8	31.75	180	39.0	22.0	18.0	5	28.70	102566
1 3/8	8	34.92	180	39.0	22.0	18.0	5	31.80	102568
1 1/2	8	38.10	200	43.0	25.0	20.0	5	35.00	102565
1 5/8	8	41.27	220	47.0	28.0	22.0	5	38.20	102569
1 3/4	8	44.45	220	47.0	28.0	22.0	5	41.40	102567
1 7/8	8	47.62	240	52.0	32.0	24.0	5	44.50	102570
2	8	50.80	205	41.0	32.0	24.0	5	47.70	102572
2 1/4	8	57.15	220	45.0	36.0	29.0	6	54.10	102571
2 1/2	8	63.50	220	45.0	36.0	29.0	6	60.40	111879

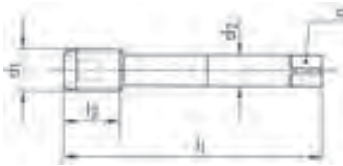

N470V-3

N470V-3



$\varnothing'' d_1$ G	P TPI	d_1 mm	l_1 mm	l_2 mm	d_2 mm	α mm			ID
$\Delta 1/2$	14	20.95	140	32.0	16.0	12.0	4	18.90	102521
$\Delta 3/4$	14	26.44	150	34.0	20.0	16.0	4	24.40	102525
1	11	33.24	160	32.0	22.0	18.0	5	30.70	102522
1 1/4	11	41.91	190	38.0	28.0	22.0	5	39.30	102519
1 1/2	11	47.80	205	41.0	32.0	24.0	5	45.20	102518
1 3/4	11	53.74	205	41.0	32.0	24.0	5	51.20	* 102520
2	11	59.61	220	45.0	36.0	29.0	6	57.00	102524
2 1/2	11	75.18	245	41.0	40.0	32.0	7	72.60	* 119565

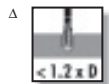

КОМБИНИРОВАННЫЕ СВЕРЛА/МЕТЧИКИ

Общая информация

ДС комбинированные сверла/метчики – два инструмента в одном, который позволяет сверлить и нарезать резьбу не меняя инструмента.

Являются оптимальным решением для станков с ЧПУ, сверлильных головок, револьверных и резьбонарезных станков.

Сфера применения

ДС комбинированные сверла/метчики рекомендуется использовать по материалам с пределом прочности до 750 Н/мм², таким как определенные стали, чугуны, алюминий, латунь.

Общие положения

- Отверстие под резьбу должно быть полностью просверлено до того как метчик начнет нарезание.
- В короткостружечных материалах глубина резьбы не должна превышать 1.8 x D (тип N5952 до 2 x D).
- В короткостружечных материалах глубина резьбы не должна превышать 1.2 x D.
- Смазка как при нарезании резьбы.

Скорости резания

Для сверлильных головок и станков с ЧПУ, идеальные скорости сверления и нарезания резьбы подобраны (см. стр.7 таблицы применяемости).

Если для сверления и нарезания резьбы выбираются одинаковые скорости, мы рекомендуем значения, приведенные ниже.

Инструкции по программированию

Зенкование:

Центровка и зенкование одновременно.

Программирование для 100 % синхронизированных подачи шпинделя и вращения (идеальный случай):

- 1) Комбинированное сверло/метчик в позиции быстрого старта
- 2) Сверление:
 - установить скорость
 - установить подачу
 - избегать длинной стружки
 - очистить стружку
- 3) Резьбонарезная секция в позиции старта
- 4) Нарезание резьбы:
 - установить скорость
 - подача = 100 % шаг резьбы
 - установить глубину резьбы
 - перед началом работы метчик должен быть очищен от стружки
- 5) Комбинированный сверло/метчик возвращается в позицию старта.

Программирование для случаев когда подача шпинделя и вращение не полностью синхронизированы:

Важно: Установите комбинированное сверло-метчик в патрон, защелкнув пружину, но вытянув осевую компенсацию.

- 1) Комбинированное сверло/метчик в позиции быстрого старта
- 2) Сверление:
 - установить скорость
 - установить подачу
 - избегать длинной стружки
 - очистить стружку
- 3) Резьбонарезная секция в позиции старта
- 4) Нарезание резьбы:
 - Установить скорость
 - подача = 90 - 95 % шага резьбы
 - установить глубину резьбы
- 5) Комбинированный сверло/метчик возвращается в позицию старта.

Скорости резания и вращения шпинделя (рекомендованные значения)

Группы материалов	м/мин.	Скорости для различных диаметров										
		M3	M4	M5	M6	M8	M10	M12	M14	M16	M18	M20
Стали до 500 Н/мм ²	20	2120	1600	1270	1060	800	640	530	460	400	360	320
Стали свыше 500 Н/мм ²	15	1600	1200	950	800	600	480	400	340	300	270	240
Чугун, мягкий	20	2120	1600	1270	1060	800	640	530	460	400	360	320
Чугун, твердый	15	1600	1200	950	800	600	480	400	340	300	270	240
Латунь	25	2650	2000	1600	1330	950	800	660	570	500	450	400
Алюминий	25	2650	2000	1600	1330	950	800	660	570	500	450	400

WIERTŁO-GWINTOWNIKI

Informacje ogólne

Wiertło-gwintowniki DC – dwa narzędzia w jednym - pozwalają na wiercenie oraz gwintowanie detalu bez zmiany narzędzia.

Jest to optymalne rozwiązanie dla obrabiarek CNC, głowic wiertarskich, tokarek rewolwerowych oraz gwintciarek.

Zastosowanie

Wiertło-gwintowniki DC są rekomendowane do obróbki materiałów o wytrzymałości na rozciąganie do 750 N/mm², takich jak stal, żeliwo szare, aluminium, mosiądz.

Ogólne wskazówki

- Obrabiany otwór musi być całkowicie przewiercony zanim gwintownik zacznie pracę.
- W materiałach z krótkim wiórem długość gwintu nie powinna przekroczyć 1.8 x D (typ N5952 do 2 x D).
- W materiałach z długim wiórem długość gwintu nie powinna przekroczyć 1.2 x D.
- Chłodziwo jak przy gwintowaniu.

Prędkości skrawania

Dla głowic wiertarskich i obrabiarek CNC dobrane są idealne prędkości przy wierceniu i gwintowaniu (patrz nasza tabela zastosowań na stronie 7).

Jeżeli ta sama prędkość jest dobrana zarówno do wiercenia jak i gwintowania, my zalecamy wartości podane poniżej.

Instrukcje programowania

Pogłębianie :

Nawiercaj i pogłębiaj jednocześnie.

Kroki programowania przy posuwie i obrotach wrzeciona w 100 % zsynchronizowanych (idealny przypadek) :

- 1) Wiertło-gwintownik w pozycji startowej (szybki posuw)
- 2) Wiercenie:
 - ustaw prędkość
 - ustaw posuw
 - zapobiegaj długim wiórom
 - usuwaj wióry
- 3) Gwintowanie - pozycja startowa
- 4) Gwintowanie:
 - ustaw prędkość
 - posuw = 100 % skoku
 - ustaw długość gwintu
 - gwintownik musi być wolny od wiórów, zanim zacznie nacinać gwint
- 5) Wiertło-gwintownik powraca na pozycję startową

Kroki programowania przy braku pełnej synchronizacji posuwu i obrotów wrzeciona :

Ważne: Zamocuj wiertło-gwintownik w oprawce z jednostronną kompensacją osiową (na wyciąganie).

- 1) Wiertło-gwintownik w szybkiej pozycji startowej
- 2) Wiercenie:
 - ustaw prędkość
 - ustaw posuw
 - zapobiegaj długim wiórom
 - usuwaj wióry
- 3) Gwintowanie – pozycja startowa
- 4) Gwintowanie:
 - ustaw prędkość
 - posuw = 90 – 95 % skoku
 - ustaw długość gwintowania
- 5) Wiertło-gwintownik powraca na pozycję startową.









Prędkości skrawania (wartości zalecane)

Grupy materiałowe	m/min	Prędkości dla różnych średnic										
		M3	M4	M5	M6	M8	M10	M12	M14	M16	M18	M20
Stale do 500 N/mm ²	20	2120	1600	1270	1060	800	640	530	460	400	360	320
Stale powyżej 500 N/mm ²	15	1600	1200	950	800	600	480	400	340	300	270	240
Żeliwo szare, miękkie	20	2120	1600	1270	1060	800	640	530	460	400	360	320
Żeliwo szare, twarde	15	1600	1200	950	800	600	480	400	340	300	270	240
Mosiądz	25	2650	2000	1600	1330	950	800	660	570	500	450	400
Aluminium	25	2650	2000	1600	1330	950	800	660	570	500	450	400

M, MF ISO DIN 13

HSSE

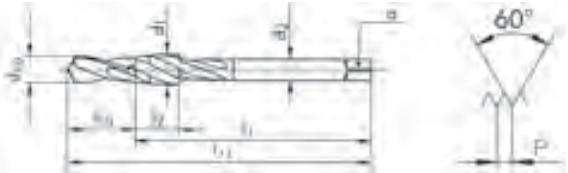



								N5951	N5952	N5951	
N5951											
N5952											
N5951											
											
								ISO 2 6H	ISO 2 6H	7H EN 60423	
$\varnothing d_1$ M	P	l_{11}	l_2	d_2	α	d_{10}	l_{10}	ID			
3	0.50	62.0	12.5	3.5	2.7	2.55	9.0	104578			
3.5	0.60	66.0	16.0	4.0	3.0	2.95	10.0	102613			
4	0.70	66.0	16.0	4.5	3.4	3.36	10.0	104580			
5	0.80	75.5	18.0	6.0	4.9	4.26	12.5	104583			
6	1.00	81.0	20.0	6.0	4.9	5.05	14.0	104585			
8	1.25	93.0	12.0	6.0	4.9	6.80	20.0	104588			
10	1.50	99.0	14.0	7.0	5.5	8.55	22.0	104571			
12	1.75	106.0	16.0	9.0	7.0	10.30	25.0	104573			
16	2.00	123.0	20.0	12.0	9.0	14.10	32.0	104576			
20	2.50	132.0	22.0	16.0	12.0	17.60	36.0	104577			
$\varnothing d_1$ M	P	l_{11}	l_2	d_2	α	d_{10}	l_{10}	ID			
3	0.50	71.0	12.5	3.5	2.7	2.55	18.0	104607			
4	0.70	77.0	16.0	4.5	3.4	3.36	21.0	104608			
5	0.80	87.0	18.0	6.0	4.9	4.26	24.0	104609			
6	1.00	94.0	20.0	6.0	4.9	5.05	27.0	104610			
8	1.25	109.0	12.0	6.0	4.9	6.80	36.0	104611			
10	1.50	118.0	14.0	7.0	5.5	8.55	41.0	104603			
12	1.75	127.0	16.0	9.0	7.0	10.30	46.0	* 104604			
16	2.00	149.0	20.0	12.0	9.0	14.10	58.0	* 104606			
$\varnothing d_1$ MF	P	l_{11}	l_2	d_2	α	d_{10}	l_{10}	ID			
4	0.50	66.0	16.0	4.5	3.4	3.55	10.0	* 104579			
5	0.50	75.5	18.0	6.0	4.9	4.55	12.5	* 104581			
5	0.75	75.5	18.0	6.0	4.9	4.31	12.5	* 123379			
8	1.00	93.0	12.0	6.0	4.9	7.05	20.0	104587			
10	1.00	99.0	14.0	7.0	5.5	9.05	22.0	104570			
$\varnothing d_1$ MF	P	l_{11}	l_2	d_2	α	d_{10}	l_{10}	ID			
12	1.50	106.0	16.0	9.0	7.0	10.55	25.0	142825			
16	1.50	123.0	16.0	12.0	9.0	14.55	32.0	142826			
20	1.50	132.0	18.0	16.0	12.0	18.55	36.0	111844			
25	1.50	155.0	22.0	18.0	14.5	23.55	45.0	111845			
32	1.50	170.0	24.0	22.0	18.0	30.55	50.0	111846			
40	1.50	203.0	28.0	32.0	24.0	38.55	63.0	* 111847			

UNC ANSI B1.1 G DIN ISO 228 PG DIN 40430

HSSE



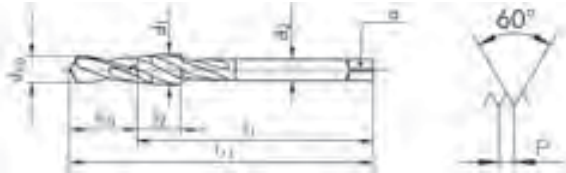
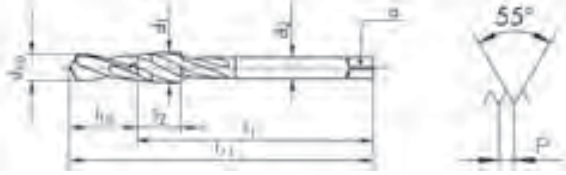
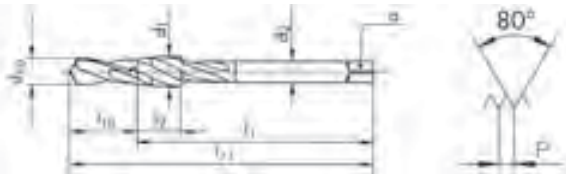























N5951									
									
									
<div style="border: 1px solid black; padding: 5px; display: inline-block;">2B</div>									
									
Ø" d ₁ UNC	P TPI	d ₁ mm	l ₁₁ mm	l ₂ mm	d ₂ mm	a mm	d ₁₀ mm	l ₁₀ mm	ID
6	32	3.50	66.0	16.0	4.0	3.0	2.80	10.0	* 104601
10	24	4.82	75.5	18.0	4.5	3.4	3.86	12.5	* 104598
1/4	20	6.35	81.0	20.0	7.0	5.5	5.15	14.0	* 104597
5/16	18	7.93	93.0	12.0	6.0	4.9	6.60	20.0	* 104600
3/8	16	9.52	93.0	12.0	7.0	5.5	8.05	20.0	* 104599
1/2	13	12.70	106.0	16.0	9.0	7.0	10.85	25.0	* 104596
									
Ø" d ₁ G	P TPI	d ₁ mm	l ₁₁ mm	l ₂ mm	d ₂ mm	a mm	d ₁₀ mm	l ₁₀ mm	ID
1/8	28	9.72	93.0	12.0	7.0	5.5	8.75	20.0	104567
1/4	19	13.15	106.0	14.0	11.0	9.0	11.75	25.0	104566
3/8	19	16.66	123.0	16.0	12.0	9.0	15.25	32.0	104569
1/2	14	20.95	132.0	18.0	16.0	12.0	19.00	36.0	104565
3/4	14	26.44	155.0	22.0	18.0	14.5	24.45	45.0	* 104568
									
Ø" d ₁ PG	P TPI	d ₁ mm	l ₁₁ mm	l ₂ mm	d ₂ mm	a mm	d ₁₀ mm	l ₁₀ mm	ID
7	20	12.50	106.0	14.0	9.0	7.0	11.40	25.0	104594
9	18	15.20	114.0	15.0	12.0	9.0	13.95	28.0	104595
11	18	18.60	132.0	18.0	14.0	11.0	17.35	36.0	104589
13.5	18	20.40	132.0	18.0	16.0	12.0	19.15	36.0	104590
16	18	22.50	142.0	20.0	18.0	14.5	21.25	40.0	* 104591
21	16	28.30	155.0	22.0	20.0	16.0	26.95	45.0	* 104592
29	16	37.00	203.0	28.0	28.0	22.0	35.65	63.0	* 104593



ТВЕРДОСПЛАВНЫЕ РЕЗЬБОВЫЕ ФРЕЗЫ И ФРЕЗЫ-СВЕРЛА PEŁNOWĘGLIKOWE FREZY DO GWINTÓW I WIERTŁO-FREZY

Пиктограммы/Примечания – Piktogramy

	Твердый сплав Monolit węglika		Длина резьбы 1.5 x D ₁ Długość gwintu 1.5 x D ₁
	10° правые спиральные канавки Rowki wiórowe prawoskrętne - 10°		Длина резьбы 2 x D ₁ Długość gwintu 2 x D ₁
	15° правые спиральные канавки Rowki wiórowe prawoskrętne - 15°		Длина резьбы 2.5 x D ₁ Długość gwintu 2.5 x D ₁
	27° правые спиральные канавки Rowki wiórowe prawoskrętne - 27°		Внутренняя резьба Gwint wewnętrzny
	27° правые спиральные канавки Rowki wiórowe prawoskrętne - 27°		Наружная резьба Gwint zewnętrzny
	С фаской 45° для зенкования Z fazą 45° do pogłębienia		Для глухих отверстий (BGF) Do otworów ślepych (BGF)
	Количество режущих кромок Ilość ostrzy		Для сквозных отверстий (BGF) Do otworów przelotowych (BGF)
	Внутренний канал подвода СОЖ Kanał do chłodzenia wewnętrznego		BGF, 2 кромки BGF, 2 ostrza
	Внутренний канал подвода СОЖ (BGF, 2 кромки) Kanał do chłodzenia wewnętrznego (BGF, 2 ostrza)		BGF, 3 кромки BGF, 3 ostrza
	Внутренний канал подвода СОЖ (BGF, 3 кромки) Kanał do chłodzenia wewnętrznego (BGF, 3 ostrza)		Для материалов < 63 HRC (GFH) Do materiałów < 63 HRC (GFH)
	Износостойкое покрытие   Powłoka zabezpieczająca przed zużyciem		Коническая резьба 1:16 (NPT - NPTF - Rc) Gwint stożkowy 1:16 (NPT - NPTF)
	Резьба EG для резьбовых вставок Gwint EG (pod wkładki HELICOIL)		

Примечание к фрезам GFM

 Во избежание дефектов профиля резьбы, важно, чтобы диаметр инструмента не превышал 2/3 диаметра резьбы изделия для резьб с основным шагом (3/4 для резьб с мелким шагом)

Uwaga przy frezach GFM

 Aby zapobiec powstawaniu defektów profilu gwintu należy pamiętać aby średnica narzędzia nie przekraczała 2/3 średnicy obrabianego otworu dla gwintów metrycznych (3/4 dla gwintów drobnoszwojnych)

Примечание к фрезам BGF

Твердосплавные резьбовые фрезы-сверла  производятся по лицензии фирмы Turchan USA и защищены одним из следующих патентов: 302915, 237035, 0265445, 175356 и DE 3627798. Продажи вне Европы должны быть согласованы с DC SWISS SA.

Uwaga przy frezach BGF

Wiertło-frezy  są produkowane na licencji Turchan USA i chronione jednym z kilku patentów : 3029915, 237035, 0265445, 175356 oraz DE 3627798. Dystrybucja poza Europą musi być zatwierdzona przez DC SWISS SA.

ПРЕИМУЩЕСТВА – ZALETY FREZÓW

GF-GFH-GFS-GFM

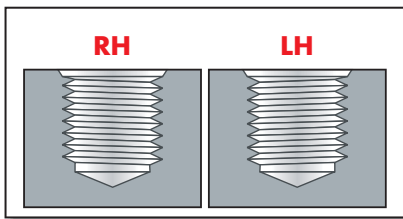

Одна и та же фреза может быть использована для образования правых и левых резьб

To samo narzędzie może wykonać gwinty prawe jak i lewe

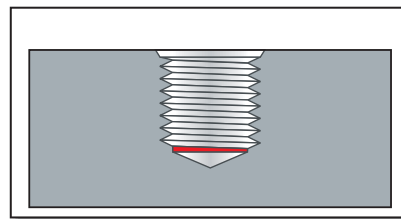

В глухих отверстиях резьбы могут быть нарезаны вплотную к доннышку

Do gwintów które muszą być nacinane blisko dna otworów nieprzelotowych

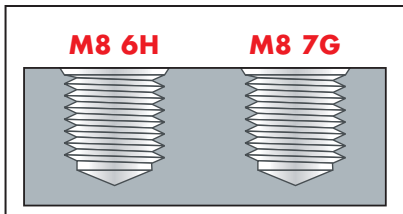

Может быть задан требуемый класс точности

Możliwość ustawienia tolerancji wg wymagań użytkownika

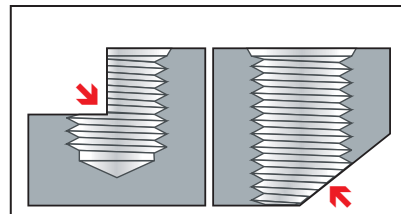

Могут быть использованы для резьб в отверстиях с неполными стенками на входе или выходе

Do gwintów przerywanych lub ze skośnym wejściem lub wyjściem

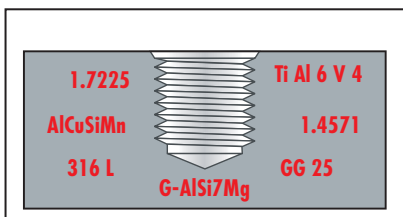

Одна фреза для обработки разных материалов. Хороший стружкоотвод благодаря оптимальному стружкодроблению
Jeden frez do obróbki różnych materiałów. Krótki wiór a dzięki temu dobra jego ewakuacja.

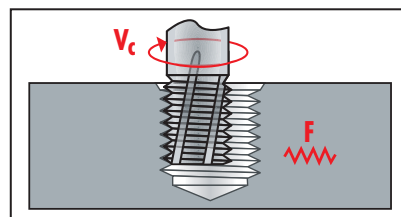

Значения скорости и подачи могут быть выбраны индивидуально для каждой детали

Prędkości skrawania oraz wartości posuwów mogą być dobierane indywidualnie do każdego materiału przedmiotu obrabianego

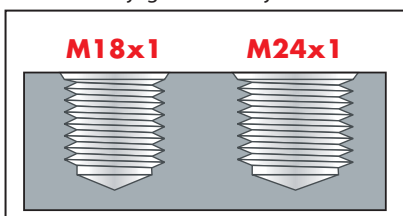

GFM

Один инструмент для большого диапазона резьб разного диаметра с одинаковым шагом (GFM)

Tylko jedno narzędzie do gwintów w szerokim zakresie średnic o tym samym skoku

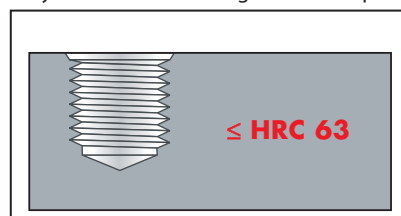

GFH

Для нарезания резьб в закаленных сталях (GFH)

Do wykonania gwintów w materiałach utwardzonych (GFH)

BGF

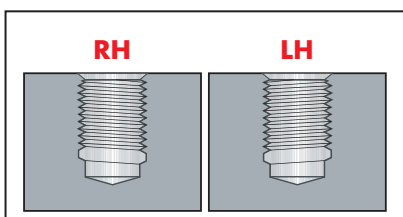

Одна и та же фреза может быть использована для образования правых и левых резьб

To samo narzędzie może wykonać gwinty prawe jak i lewe

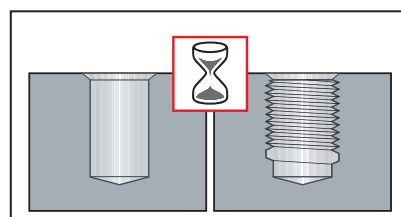

Экономия вспомогательного времени на замене инструмента и пространства в магазине станка

Oszczędność czasu wymiany narzędzia oraz miejsca w magazynie obrabiarki

ЦИКЛЫ – CYKLE

Рабочий цикл фрез типа GF – Cykl operacyjny, typ GF

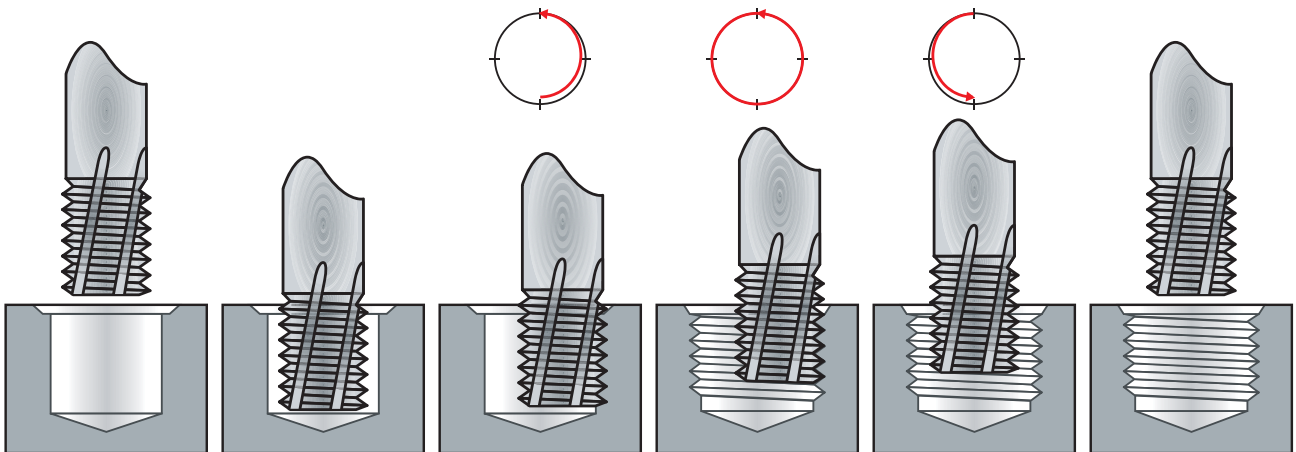

Рабочий цикл фрез типа BGF – Cykl operacyjny, typ BGF

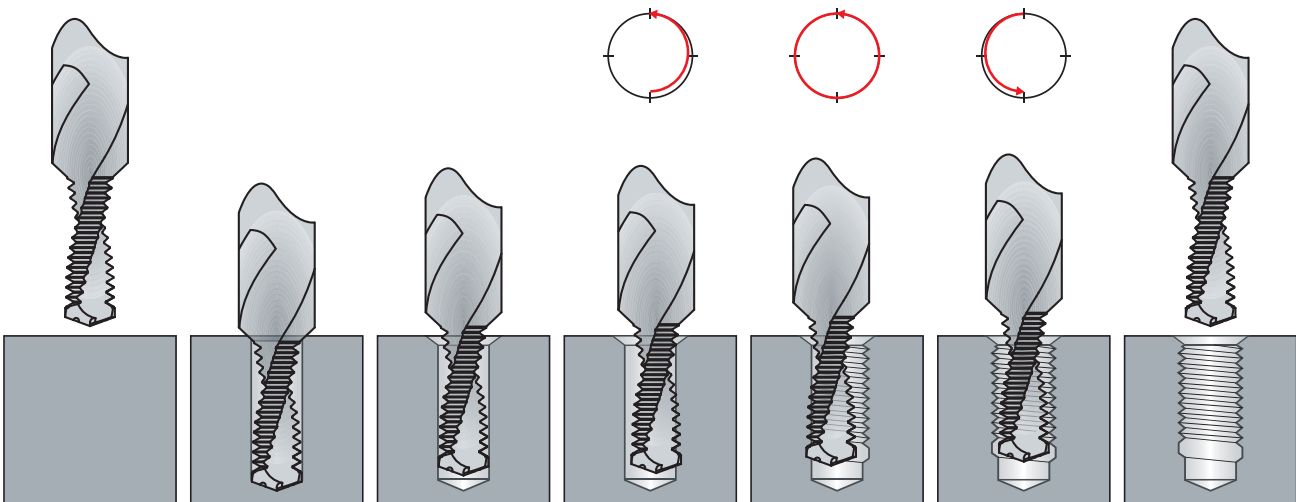

Специальные исполнение – Wykonania specjalne

Заточка для образования
торцевой площадки

Pogłębiacz czołowy

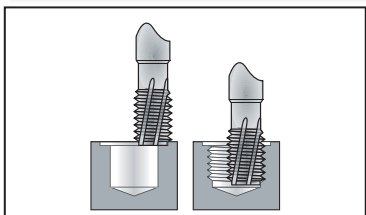

GFMS

Заточка для образования
площадки и 90° фаски

Pogłębiacz czołowy i fazownik 90°

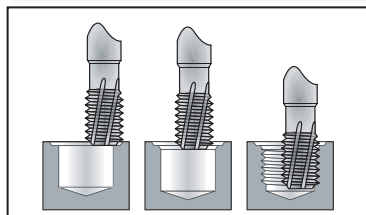

GFMS

С 45° круговой фаской для
зенкования



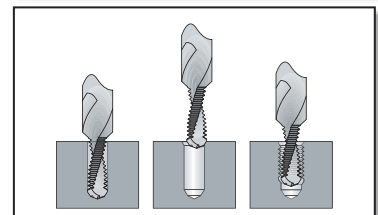





Z nakrojem kołystym 45° do
wykonywania pogłębień



BGFS

Указатель – Твердосплавные резьбовые фрезы тип GF
 Skorowidz – Pełnowęglkowe frezy do gwintów, typ GF

GF-GFH-
GFS-GFM-BGF

		GF											
Тип Typ		GF6110 GF6110VS		GF6160 GF6160VS		GF6115 GF6115VS		GF6165 GF6165VS		GF6116 GF6116VS		GF6166 GF6166VS	
Покрытие Powłoka		VS		VS		VS		VS		VS		VS	
Длина резьбы Długość gwintu													
Характеристики Charakterystyki													
M	ISO DIN 13	194				195		195		196		196	
MF	ISO DIN 13	197						198				198	
UNC	ANSI B1.1	199						200				200	
UNF	ANSI B1.1	201						202				202	
UN	ANSI B1.1												
G	DIN ISO 228							203				203	
PG	DIN 40430												
NPT	ANSI B1.20.1			204									
NPTF	ANSI B1.20.3			204									
EG M	DIN 8140												

Указатель – Твердосплавные резьбовые фрезы тип GFH и GFS
 Skorowidz – Pełnowęglkowe frezy do gwintów, typ GFH i GFS

		GFH		GFS								
Тип		GFH6110VS	GFS6610	GFS6610VS	GFS6660	GFS6660VS	GFS6615	GFS6615VS	GFS6665	GFS6665VS	GFS6616	GFS6616VS
Покрытие Powłoka												
Длина резьбы Długość gwintu												
Характеристики Charakterystyki												
M	ISO DIN 13	194	205		205		206		206		207	
MF	ISO DIN 13		208		208		209		209			
UNC	ANSI B1.1		210		210		211		211			
UNF	ANSI B1.1		212		212		213		213			
UN/EF/S	ANSI B1.1											
G	DIN ISO 228				214				214			
PG	DIN 40430											
NPT	ANSI B1.20.1				215							
NPTF	ANSI B1.20.3				215							
EG M	DIN 8140											

Указатель – Твердосплавные резьбовые фрезы фрезы-сверла тип GFM и BGF
 Skorowidz – Pełnowęglkowe frezy do gwintów i wiertło-frezy, typ GFM i BGF

		GFM		BGF									
GFS6666	GFS6666VS	GFM6260	GFM6260VS	BGF6760	BGF6760VS	BGF6765	BGF6765VS	BGF6766	BGF6766VS	BGF6865	BGF6865VS	BGF6866	BGF6866VS
VS		VS		VS		VS		VS		VS		VS	
207	216	220	221	221	222	222							
	216	223	223										
	217												
	217												
	217												
	218												
	218												
	219												
	219												

GF - GFH

GF6110



GF6110VS



VS

GFH6110VS



VS

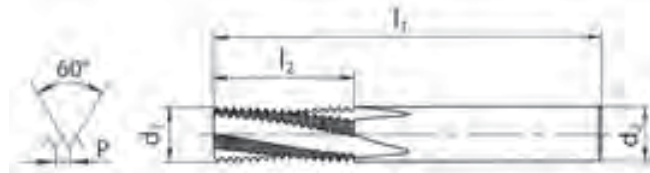

GF6110

GF6110VS

GFH6110VS



HRC
≤ 63



∅ D ₁ M	P mm	d ₁ mm	l ₁ mm	l ₂ mm	d ₂ mm	GF	GFH	
2	0.40	1.50	48	3.4	6	2		1.60
2.5	0.45	1.90	48	4.3	6	3		2.05
3	0.50	2.30	48	5.3	6	3	3	2.50
3.5	0.60	2.70	48	6.3	6	3		2.90
4	0.70	3.00	48	7.4	6	3	3	3.30
5	0.80	3.80	48	9.2	6	3	4	4.20
6	1.00	4.50	54	10.5	6		4	5.00
8	1.25	5.95	54	13.1	6		5	6.80
10	1.50	7.95	64	17.3	8		5	8.50
12	1.75	9.95	74	20.1	10		5	10.20

ID

ID

ID

125233

115993

150565

152124

125660

116395

150072

116350

135217

125944

116396

150073

126158

116397

150074

150075

150076

150077

151326

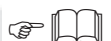

GF

GF6115



GF6115VS



VS

GF6165



GF6165VS



VS

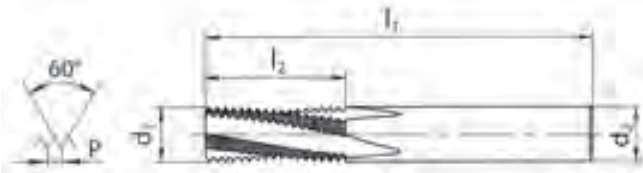

GF6115

GF6115VS

GF6165

GF6165VS



∅ D ₁ M	P mm	d ₁ mm	l ₁ mm	l ₂ mm	d ₂ mm		
4	0.70	3.00	48	8.8	6	3	3.30
5	0.80	3.80	48	10.8	6	3	4.20
6	1.00	4.50	54	13.5	6	3	5.00
8	1.25	5.95	54	18.1	6	3	6.80
10	1.50	7.95	64	21.8	8	4	8.50
12	1.75	9.95	72	25.4	10	4	10.20
14	2.00	9.95	74	31.0	10	4	12.00
16	2.00	11.95	80	35.0	12	4	14.00
18	2.50	13.95	90	41.3	14	4	15.50
20							17.50

ID

ID

ID

ID

146298

146969

146299

146970

146300

146971

126350

116398

146321

146972

126586

116399

146322

146973

124836

116400

116342

116401

125066

116402

125114

115990

125229

116403



262

GF

GF6116



GF6116VS



VS

GF6166



GF6166VS



VS

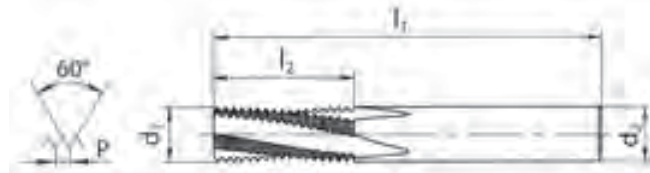

GF6116

GF6116VS

GF6166

GF6166VS



$\varnothing D_1$ M	P mm	d_1 mm	l_1 mm	l_2 mm	d_2 mm		
4	0.70	3.00	48	10.9	6	3	3.30
5	0.80	3.80	48	13.2	6	3	4.20
6	1.00	4.50	54	16.5	6	3	5.00
8	1.25	5.95	54	21.9	6	3	6.80
10	1.50	7.95	64	26.3	8	4	8.50
12	1.75	9.95	74	32.4	10	4	10.20
14	2.00	9.95	74	37.0	10	4	12.00
16	2.00	11.95	90	43.0	12	4	14.00
18	2.50	13.95	105	53.8	14	4	15.50
20							17.50

ID

ID

ID

ID

155365

155370

155366

155371

155367

155372

155375

155382

155368

155373

155376

155383

155369

155374

155377

155384

155378

155385

155379

155386

155380

155387

155381

155388



GF

GF6110



GF6110VS



GF6110

GF6110VS

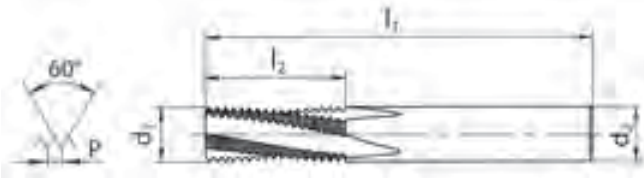

∅ D ₁ MF	P mm	d ₁ mm	l ₁ mm	l ₂ mm	d ₂ mm		
4	0.50	3.00	48	7.3	6	3	3.50
5	0.50	3.80	48	8.8	6	3	4.50

ID

ID

135218

135219

135069

135220



262

GF

GF6165



GF6165VS



GF6166



GF6166VS

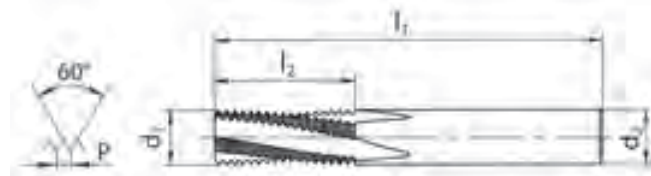

GF6165

GF6165VS

GF6166

GF6166VS



∅ D ₁ MF	P mm	d ₁ mm	l ₁ mm	l ₂ mm	d ₂ mm		
6	0.50	4.50	54	12.8	6	3	5.50
6	0.75	4.50	54	13.1	6	3	5.25
8	0.50	5.95	54	17.8	6	3	7.50
8	0.75	5.95	54	16.9	6	3	7.25
8	1.00	5.95	54	17.5	6	3	7.00
10	1.00	7.95	64	21.5	8	4	9.00
10	1.25	7.95	64	21.9	8	4	8.80
12	1.00	9.95	72	25.5	10	4	11.00
12	1.50	9.95	72	26.3	10	4	10.50

ID

ID

135221	135222
123664	123665
135002	135223
143110	135224
124239	116404
119986	116405
120102	116406
120303	116407
120392	120393

∅ D ₁ MF	P mm	d ₁ mm	l ₁ mm	l ₂ mm	d ₂ mm		
6	0.50	4.50	54	15.8	6	3	5.50
6	0.75	4.50	54	16.1	6	3	5.25
8	0.50	5.95	54	20.8	6	3	7.50
8	0.75	5.95	54	20.6	6	3	7.25
8	1.00	5.95	54	21.5	6	3	7.00
10	1.00	7.95	64	26.5	8	4	9.00
10	1.25	7.95	64	26.9	8	4	8.80
12	1.00	9.95	74	31.5	10	4	11.00
12	1.50	9.95	74	32.3	10	4	10.50

ID

ID

155389	155398
155390	155399
155391	155400
155392	155401
155393	155402
155394	155403
155395	155404
155396	155405
155397	155406



GF

GF6110



GF6110VS



GF6110

GF6110VS

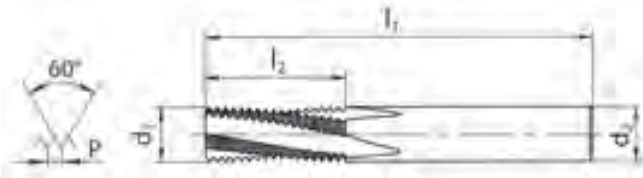

Ø" D ₁ UNC	P TPI	d ₁ mm	l ₁ mm	l ₂ mm	d ₂ mm		
10	24	3.60	48	10.1	6.0	3	3.80
12	24	4.10	48	10.1	6.0	3	4.40
1/4	20	4.80	54	12.1	6.0	3	5.10

ID

ID

135225

135226

135227

135228

135229

135230



262

GF

GF6165



GF6165VS



GF6166



GF6166VS



GF6165

GF6165VS

GF6166

GF6166VS

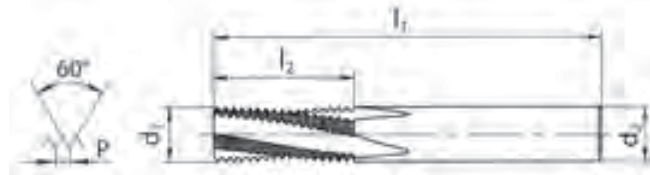

\varnothing " D ₁ UNC	P TPI	d ₁ mm	l ₁ mm	l ₂ mm	d ₂ mm		
---------------------------------------	----------	----------------------	----------------------	----------------------	----------------------	--	--

1/4	20	4.80	54	14.6	6.0	3	5.10
5/16	18	5.95	54	17.6	6.0	3	6.50
3/8	16	7.10	64	21.5	8.0	4	8.00
7/16	14	7.95	64	24.5	8.0	4	9.30
1/2	13	9.95	72	28.4	10.0	4	10.80

ID

ID

155407	155408
116047	135231
135232	135233
116049	135234
135235	135236

\varnothing " D ₁ UNC	P TPI	d ₁ mm	l ₁ mm	l ₂ mm	d ₂ mm		
---------------------------------------	----------	----------------------	----------------------	----------------------	----------------------	--	--

1/4	20	4.80	54	17.1	6.0	3	5.10
5/16	18	5.95	54	21.9	6.0	3	6.50
3/8	16	7.10	64	26.2	8.0	4	8.00
7/16	14	7.95	64	29.9	8.0	4	9.30
1/2	13	9.95	74	34.2	10.0	4	10.80

ID

ID

155409	155414
155410	155415
155411	155416
155412	155417
155413	155418

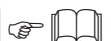

UNF ANSI B1.1

VHM
CAR



HB
HE

sur demande
auf Anfrage
on request
su richiesta
sobre pedido

GF

GF6110



GF6110VS



VS

GF6110

GF6110VS

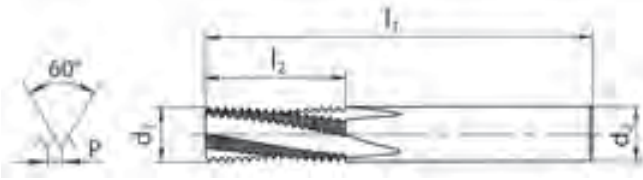

Ø" D ₁ UNF	P TPI	d ₁ mm	l ₁ mm	l ₂ mm	d ₂ mm		
10	32	3.60	48	8.3	6.0	3	4.05
12	28	4.10	48	9.5	6.0	3	4.60
1/4	28	4.80	54	11.3	6.0	3	5.50

ID

ID

128659

135237

135238

135239

135240

135176



262

GF

UNF ANSI B1.1

VHM
CAR



HB
HE

sur demande
auf Anfrage
on request
su richiesta
sobre pedido

GF

GF6165



GF6165VS



GF6166



GF6166VS



GF6165

GF6165VS

GF6166

GF6166VS

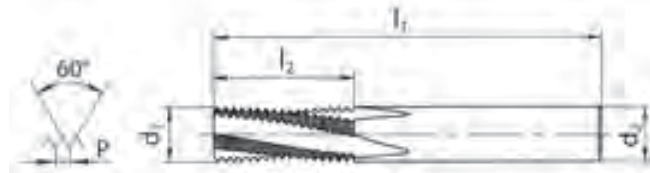

Ø" D ₁	P	d ₁	l ₁	l ₂	d ₂		
UNF	TPI	mm	mm	mm	mm		

1/4	28	4.80	54	14.1	6.0	3	5.50
5/16	24	5.95	54	17.5	6.0	3	6.90
3/8	24	7.95	64	20.6	8.0	4	8.50
7/16	20	7.95	64	24.8	8.0	4	9.80
1/2	20	9.95	72	27.3	10.0	4	11.40

ID

ID

155419	155420
135242	135243
135182	135245
135246	135247
135183	135249

Ø" D ₁	P	d ₁	l ₁	l ₂	d ₂		
UNF	TPI	mm	mm	mm	mm		

1/4	28	4.80	54	16.8	6.0	3	5.50
5/16	24	5.95	54	20.6	6.0	3	6.90
3/8	24	7.95	64	24.9	8.0	4	8.50
7/16	20	7.95	64	28.6	8.0	4	9.80
1/2	20	9.95	74	33.7	10.0	4	11.40

ID

ID

155421	155426
155422	155427
155423	155428
155424	155429
155425	155430



262

GF

GF6165



GF6165VS



GF6166



GF6166VS



GF6165

GF6165VS

GF6166

GF6166VS

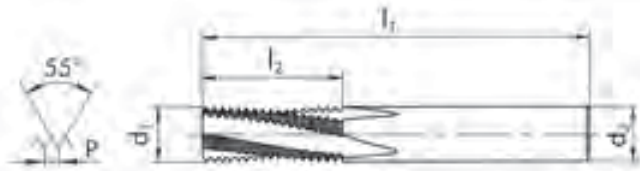
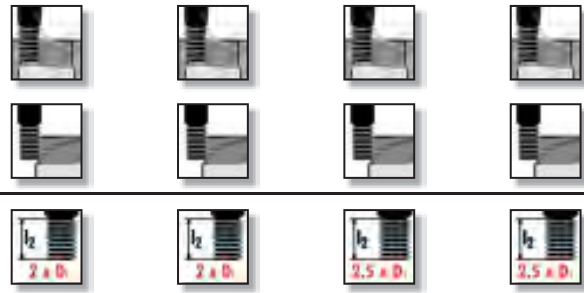

$\varnothing'' D_1$ G	P TPI	d_1 mm	l_1 mm	l_2 mm	d_2 mm		
1/8	28	7.95	64	15.9	8.0	4	8.75
1/4	19	9.95	72	22.1	10.0	4	11.60
3/8	19	13.60	80	27.4	14.0	4	15.20

ID

ID

119347 116409
119292 116410
119678 116411

$\varnothing'' D_1$ G	P TPI	d_1 mm	l_1 mm	l_2 mm	d_2 mm		
1/8	28	7.95	64	24.9	8.0	4	8.75
1/4	19	9.95	74	34.1	10.0	4	11.60
3/8	19	13.60	90	43.4	14.0	4	15.20

ID

ID

155431 155434
155432 155435
155433 155436



262

NPT, NPTF

ANSI B1.20.1
ANSI B1.20.3

VHM
CAR

DIN 6535 HA

HB
HE

sur demande
auf Anfrage
on request
su richiesta
sobre pedido

GF

GF6160



GF6160VS



GF6160

GF6160VS

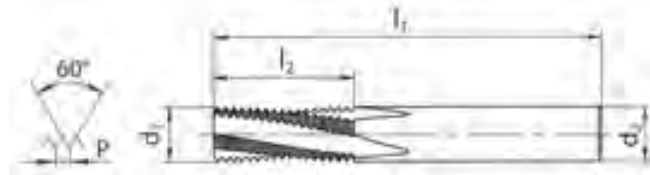

Ø" D ₁ NPT	P TPI	d ₁ mm	l ₁ mm	l ₂ mm	d ₂ mm	4
1/8	27	7.30	64	9.9	8.0	4
1/4	18	9.95	72	14.8	12.0	4
3/8	18	12.50	80	14.8	14.0	4
1/2	14	14.70	90	19.0	16.0	4

ID

ID

116371	116435
135250	135251
135252	135253
155437	155438

Ø" D ₁ NPTF	P TPI	d ₁ mm	l ₁ mm	l ₂ mm	d ₂ mm	4
1/8	27	7.30	64	9.9	8.0	4
1/4	18	9.95	72	14.8	12.0	4
3/8	18	12.50	80	14.8	14.0	4
1/2	14	14.70	90	19.0	16.0	4

ID

ID

* 135254	* 135255
135256	135257
135258	135259
155439	155440

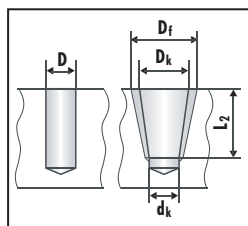

Ø D ₁	Avant-trou Prefori			Fraisage Fresatura	
	D	d _k	D _k	D _f	L ₂
1/8	8.5	8.3	8.85	9.81	6.92
1/4	11.1	10.8	11.48	12.99	10.02
3/8	14.5	14.2	14.92	16.41	10.33
1/2	17.9	17.5	18.42	20.37	13.57

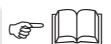

262

GFS

GFS6610



GFS6610VS

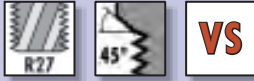

GFS6660



GFS6660VS



GFS6610

GFS6610VS

GFS6660

GFS6660VS

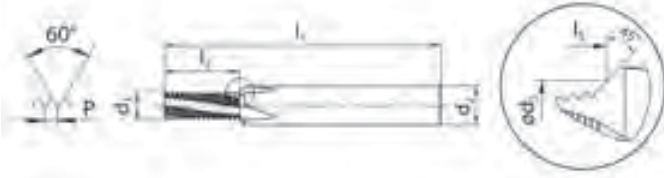

Ø D ₁ M	P mm	d ₁ mm	l ₁ mm	l ₂ mm	l ₃ mm	d _s mm	d ₂ mm			ID	ID	ID	ID
2	0.40	1.50	48	3.4	3.7	2.1	6	2	1.60	135331	135332		
2.5	0.45	1.90	48	4.3	4.7	2.6	6	3	2.05	155441	155443		
3	0.50	2.30	48	5.3	5.6	3.1	6	3	2.50	135333	135334		
3.5	0.60	2.70	48	5.7	6.2	3.6	6	3	2.90	155442	155444		
4	0.70	3.00	48	7.3	7.9	4.1	6	3	3.30	135335	135336		
5	0.80	3.80	54	9.2	9.9	5.1	6	3	4.20	135337	135338		
6	1.00	4.50	62	10.5	11.3	6.2	8	3	5.00	135339	116175		
8	1.25	5.95	74	13.1	14.3	8.2	10	3	6.80			135340	116172
10	1.50	7.95	80	17.3	18.4	10.3	12	4	8.50			135341	116173
12	1.75	9.95	90	20.1	21.3	12.3	14	4	10.20			135342	116174
14	2.00	10.80	102	25.0	26.8	14.4	16	4	12.00			135343	135344
16	2.00	12.80	102	27.0	28.8	16.4	18	4	14.00			135345	135346
18	2.50	13.95	125	33.8	36.0	18.5	25	4	15.50			135347	135348
20					37.0	20.5			17.50				



GFS

GFS6615



GFS6615VS



GFS6665



GFS6665VS

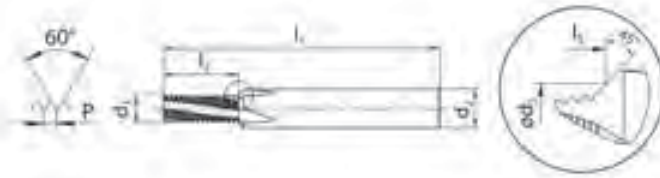

GFS6615

GFS6615VS

GFS6665

GFS6665VS



Ø D ₁ M	P mm	d ₁ mm	l ₁ mm	l ₂ mm	l _s mm	d _s mm	d ₂ mm		
2	0.40	1.50	48	4.6	4.9	2.1	6	2	1.60
2.5	0.45	1.90	48	5.6	6.0	2.6	6	3	2.05
3	0.50	2.30	48	6.8	7.1	3.1	6	3	2.50
3.5	0.60	2.70	48	7.5	8.0	3.6	6	3	2.90
4	0.70	3.00	48	8.8	9.3	4.1	6	3	3.30
5	0.80	3.80	54	10.8	11.5	5.1	6	3	4.20
6	1.00	4.50	62	13.5	14.3	6.2	8	3	5.00
8	1.25	5.95	74	18.1	19.3	8.2	10	3	6.80
10	1.50	7.95	80	21.8	22.9	10.3	12	4	8.50
12	1.75	9.95	90	25.4	26.6	12.3	14	4	10.20
14	2.00	10.80	102	31.0	32.8	14.4	16	4	12.00
16	2.00	12.80	102	35.0	36.8	16.4	18	4	14.00
18	2.50	13.95	125	41.3	43.5	18.5	25	4	15.50
20					44.5	20.5			17.50

ID

ID

ID

ID

135349

135350

155445

155447

125661

135351

155446

147108

125946

135352

126160

116178

126352

135353

155524

155525

126587

116343

124837

135354

124973

135355

125067

135356

125116

135357

125231

135358



GFS

GFS6616 GFS6616VS GFS6666 GFS6666VS

GFS6616



GFS6616VS



GFS6666



GFS6666VS

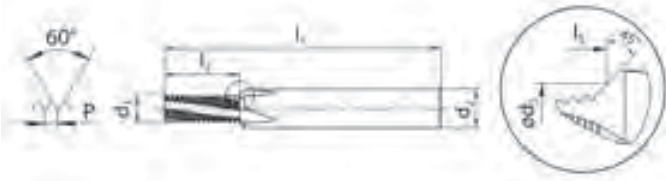

Ø D ₁ M	P mm	d ₁ mm	l ₁ mm	l ₂ mm	l ₃ mm	d _s mm	d ₂ mm			ID	ID	ID	ID
3	0.50	2.30	48	8.3	8.7	3.1	6	3	2.50	155448	155452		
4	0.70	3.00	48	10.9	11.5	4.1	6	3	3.30	155449	155453		
5	0.80	3.80	54	13.2	13.9	5.1	6	3	4.20	155450	155454		
6	1.00	4.50	62	16.5	17.4	6.2	8	3	5.00	155451	155455	155456	155463
8	1.25	5.95	74	21.9	23.0	8.2	10	3	6.80			155457	155464
10	1.50	7.95	80	26.3	27.5	10.3	12	4	8.50			155458	155465
12	1.75	9.95	90	32.4	33.6	12.3	14	4	10.20			155459	155466
14	2.00	10.80	102	37.0	38.8	14.4	16	4	12.00			155460	155467
16	2.00	12.80	102	43.0	44.8	16.4	18	4	14.00			155461	155468
18	2.50	13.95	125	53.8	56.1	18.5	25	4	15.50			155462	155469
20					57.1	20.5			17.50				

GFS

GFS6610



GFS6610VS



GFS6660



GFS6660VS

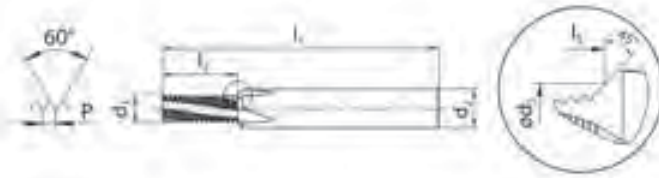

GFS6610

GFS6610VS

GFS6660

GFS6660VS



∅ D ₁ MF	P mm	d ₁ mm	l ₁ mm	l ₂ mm	l _s mm	d _s mm	d ₂ mm		
4	0.50	3.00	48	7.3	7.8	4.1	6	3	3.50
5	0.50	3.80	54	8.8	9.4	5.1	6	3	4.50
6	0.50	4.50	62	9.8	10.6	6.2	8	3	5.50
6	0.75	4.50	62	10.1	11.0	6.2	8	3	5.25
8	0.50	5.95	74	12.8	13.9	8.2	10	3	7.50
8	0.75	5.95	74	13.1	14.3	8.2	10	3	7.25
8	1.00	5.95	74	13.5	14.6	8.2	10	3	7.00
10	1.00	7.95	80	16.5	17.7	10.3	12	4	9.00
10	1.25	7.95	80	16.9	18.0	10.3	12	4	8.80
12	1.00	9.95	90	19.5	20.7	12.3	14	4	11.00
12	1.50	9.95	90	20.3	21.4	12.3	14	4	10.50
14	1.50	10.80	102	23.3	25.0	14.4	16	4	12.50
16	1.50	12.80	102	26.3	28.1	16.4	18	4	14.50

ID

ID

ID

ID

135359

135360

135361

135362

135363

135364

135365

135366

135367

135368

135369

135370

135371

135372

135373

135374

135375

135376

135377

135378

135379

135380

135381

135382

135383

135384

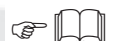

GFS

GFS6615



GFS6615VS



GFS6665



GFS6665VS



GFS6615

GFS6615VS

GFS6665

GFS6665VS

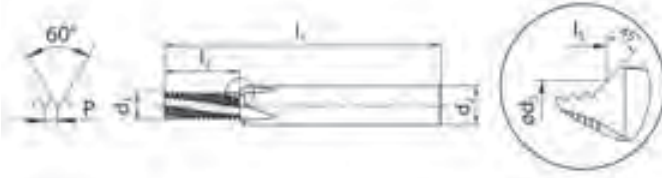

∅ D ₁ MF	P mm	d ₁ mm	l ₁ mm	l ₂ mm	l ₃ mm	d _s mm	d ₂ mm			ID	ID	ID	ID
4	0.50	3.00	48	8.8	9.3	4.1	6	3	3.50	135385	135386		
5	0.50	3.80	54	10.8	11.4	5.1	6	3	4.50	135387	135388		
6	0.50	4.50	62	12.8	13.6	6.2	8	3	5.50	135389	135390		
6	0.75	4.50	62	13.1	14.0	6.2	8	3	5.25	135391	135392		
8	0.50	5.95	74	17.8	18.9	8.2	10	3	7.50			135393	135394
8	0.75	5.95	74	16.9	18.0	8.2	10	3	7.25			135395	135396
8	1.00	5.95	74	17.5	18.6	8.2	10	3	7.00			135397	135398
10	1.00	7.95	80	21.5	22.7	10.3	12	4	9.00			135399	135400
10	1.25	7.95	80	21.9	23.0	10.3	12	4	8.80			135401	135402
12	1.00	9.95	90	25.5	26.7	12.3	14	4	11.00			135403	135404
12	1.50	9.95	90	26.3	27.4	12.3	14	4	10.50			135405	135406
14	1.50	10.80	102	30.8	32.5	14.4	16	4	12.50			135407	135408
16	1.50	12.80	102	33.8	35.6	16.4	18	4	14.50			135409	135410



262

GFS

GFS6610



GFS6610VS

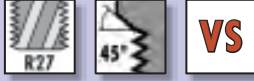

GFS6660



GFS6660VS

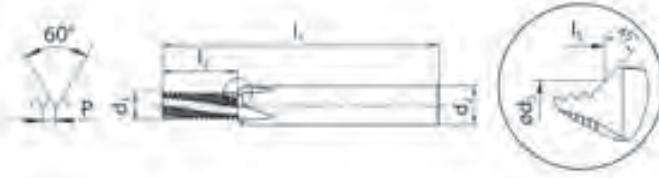

GFS6610

GFS6610VS

GFS6660

GFS6660VS



Ø" D ₁ UNC	P TPI	d ₁ mm	l ₁ mm	l ₂ mm	l _s mm	d _s mm	d ₂ mm		
10	24	3.60	54	10.1	10.7	4.9	6	3	3.80
12	24	4.10	54	10.1	10.8	5.6	6	3	4.40
1/4	20	4.80	62	12.1	12.9	6.5	8	3	5.10
5/16	18	5.95	74	14.8	15.9	8.1	10	3	6.50
3/8	16	7.10	80	16.7	18.0	9.8	12	4	8.00
7/16	14	7.95	80	19.0	20.8	11.4	12	4	9.30
1/2	13	9.95	90	22.5	24.0	13.0	14	4	10.80
9/16	12	10.80	102	24.4	26.3	14.6	16	4	12.20
5/8	11	11.90	102	26.5	28.8	16.3	18	4	13.60

ID

ID

ID

ID

135420

135421

135422

135423

135424

135425

155470

155473

135426

135427

155471

155474

135428

135429

155472

155475

135430

135431

135432

135433

135434

135435

135436

135437

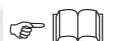

GFS

GFS6615



GFS6615VS

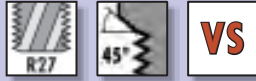

GFS6665



GFS6665VS

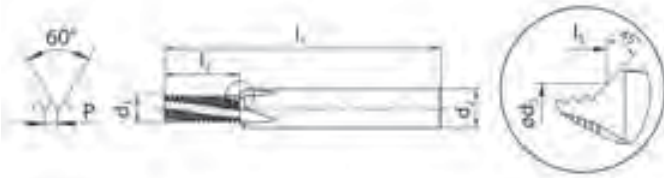

GFS6615



GFS6615VS



GFS6665



GFS6665VS



∅" D ₁ UNC	P TPI	d ₁ mm	l ₁ mm	l ₂ mm	l _s mm	d _s mm	d ₂ mm		
10	24	3.60	54	12.2	12.8	4.9	6	3	3.80
12	24	4.10	54	13.2	14.0	5.6	6	3	4.40
1/4	20	4.80	62	14.6	15.5	6.5	8	3	5.10
5/16	18	5.95	74	17.6	18.7	8.1	10	3	6.50
3/8	16	7.10	80	21.5	22.8	9.8	12	4	8.00
7/16	14	7.95	80	24.5	26.2	11.4	12	4	9.30
1/2	13	9.95	90	28.4	29.9	13.0	14	4	10.80
9/16	12	10.80	102	32.8	34.7	14.6	16	4	12.20
5/8	11	11.90	102	35.8	38.0	16.3	18	4	13.60

ID

ID

ID

ID

135438

135439

135440

135441

135442

135443

155476

155479

135444

135445

155477

155480

135446

135447

155478

155481

135448

135449

135450

135451

135452

135453

135454

135455



262

GFS

GFS6610



GFS6610VS



GFS6660

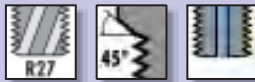

GFS6660VS



GFS6610

GFS6610VS

GFS6660

GFS6660VS



Ø" D ₁ UNF	P TPI	d ₁ mm	l ₁ mm	l ₂ mm	l _s mm	d _s mm	d ₂ mm		
10	32	3.60	54	8.3	9.0	4.9	6	3	4.05
12	28	4.10	54	9.5	10.3	5.6	6	3	4.60
1/4	28	4.80	62	11.3	12.2	6.5	8	3	5.50
5/16	24	5.95	74	13.2	14.3	8.1	10	3	6.90
3/8	24	7.95	80	16.4	17.3	9.8	12	4	8.50
7/16	20	7.95	80	18.4	20.1	11.4	12	4	9.80
1/2	20	9.95	90	21.0	22.5	13.0	14	4	11.40
9/16	18	11.60	102	23.3	24.8	14.6	16	4	12.90
5/8	18	11.90	102	26.1	28.3	16.3	18	4	14.50

ID

ID

ID

ID

135456

135457

135458

135459

135460

135461

155482

155485

135462

135463

155483

155486

135464

135465

155484

155487

135466

135467

135468

135469

135470

135471

135472

135473

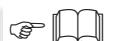

GFS

GFS6615



GFS6615VS



GFS6665

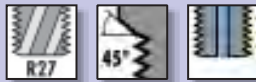

GFS6665VS

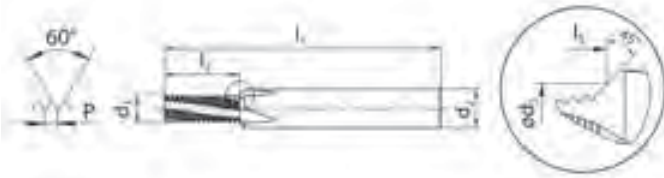

GFS6615



GFS6615VS



GFS6665



GFS6665VS



Ø" D ₁ UNF	P TPI	d ₁ mm	l ₁ mm	l ₂ mm	l _s mm	d _s mm	d ₂ mm		
10	32	3.60	54	11.5	12.2	4.9	6	3	4.05
12	28	4.10	54	12.3	13.0	5.6	6	3	4.60
1/4	28	4.80	62	14.1	14.9	6.5	8	3	5.50
5/16	24	5.95	74	17.5	18.6	8.1	10	3	6.90
3/8	24	7.95	80	20.6	21.5	9.8	12	4	8.50
7/16	20	7.95	80	24.8	26.5	11.4	12	4	9.80
1/2	20	9.95	90	27.3	28.8	13.0	14	4	11.40
9/16	18	11.60	102	30.4	31.9	14.6	16	4	12.90
5/8	18	11.90	102	34.6	36.8	16.3	18	4	14.50

ID

ID

ID

ID

128660

135474

135475

135476

128578

135477

155488

155491

135478

135479

155489

155492

135480

135481

155490

155493

135482

135483

135484

135485

135486

135487

135488

135489



262

GFS

GFS6660



GFS6660VS



GFS6665



GFS6665VS

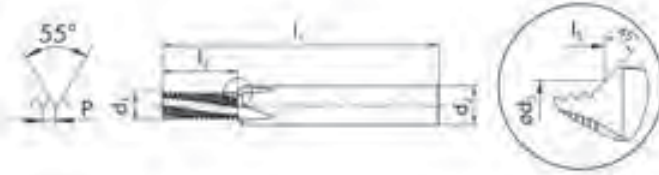

GFS6660

GFS6660VS

GFS6665

GFS6665VS

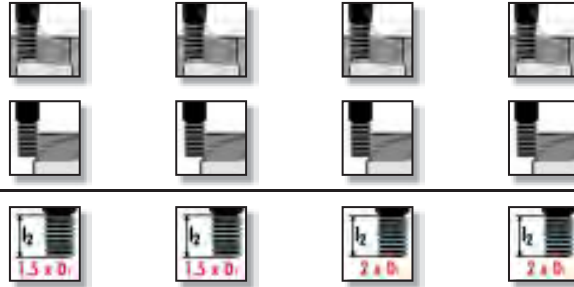

\varnothing'' D ₁ G	P TPI	d ₁ mm	l ₁ mm	l ₂ mm	l _s mm	d _s mm	d ₂ mm		
1/8	28	7.95	80	15.9	16.9	10.0	12	4	8.75
1/4	19	9.95	90	22.1	23.8	13.5	14	4	11.60
3/8	19	12.80	102	27.4	29.5	17.1	18	4	15.20

ID

ID

135411 135412
135413 135414
135415 135416

\varnothing'' D ₁ G	P TPI	d ₁ mm	l ₁ mm	l ₂ mm	l _s mm	d _s mm	d ₂ mm		
1/8	28	7.95	80	21.3	22.3	10.0	12	4	8.75
1/4	19	9.95	90	28.7	30.5	13.5	14	4	11.60
3/8	19	12.80	102	35.4	37.6	17.1	18	4	15.20

ID

ID

119349 135417
119298 135418
119680 135419

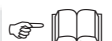

NPT, NPTF

ANSI B1.20.1
ANSI B1.20.3

VHM
CAR



HB
HE

sur demande
auf Anfrage
on request
su richiesta
sobre pedido

GFS

GFS6660



GFS6660VS



GFS6660

GFS6660VS

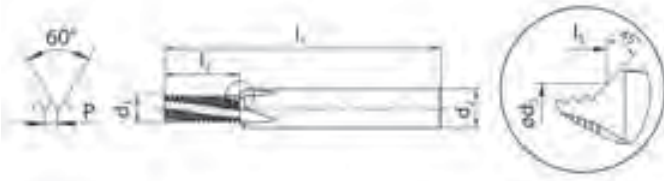

Ø" D ₁ NPT	P TPI	d ₁ mm	l ₁ mm	l ₂ mm	l ₃ mm	d _s mm	d ₂ mm	
1/8	27	7.30	70	9.9	11.2	10.6	12	4
1/4	18	9.95	80	14.8	16.4	14.0	16	4
3/8	18	12.50	80	14.8	16.9	17.6	18	4

ID

ID

126910

135490

126899

135491

126928

135492

Ø" D ₁ NPTF	P TPI	d ₁ mm	l ₁ mm	l ₂ mm	l ₃ mm	d _s mm	d ₂ mm	
1/8	27	7.30	70	9.9	11.2	10.6	12	4
1/4	18	9.95	80	14.8	16.4	14.0	16	4
3/8	18	12.50	80	14.8	16.9	17.6	18	4

ID

ID

135493

135494

135495

135496

135497

135498

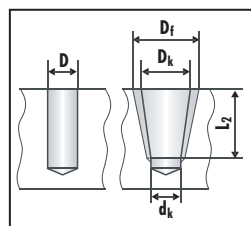

Ø D ₁	Avant-trou Prefori			Fraisage Fresatura	
	D	d _k	D _k	D _f	L ₂
1/8	8.5	8.3	8.85	9.81	6.92
1/4	11.1	10.8	11.48	12.99	10.02
3/8	14.5	14.2	14.92	16.41	10.33



262

GFM

GFM6260

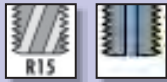

GFM6260VS



GFM6260

GFM6260VS

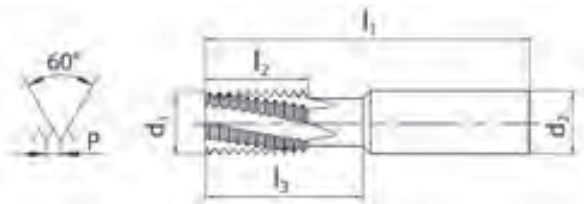

d ₁ mm	P mm	∅ D ₁ ≥ M, MF	l ₁ mm	l ₂ mm	l ₃ mm	d ₂ mm	✎	ID	ID
8	0.50	10	64	16.0	16	8.0	4	116450	135260
8	0.75	10	64	15.8	16	8.0	4	116340	135261
10	0.75	14	70	15.8	26	10.0	4	116128	135262
10	1.00	14	70	16.0	26	10.0	4	118657	135263
10	1.25	14	70	16.3	26	10.0	4	118659	135264
10	1.50	14	70	16.5	26	10.0	4	118661	135265
12	0.50	18	80	20.0	32	12.0	4	116129	135214
12	0.75	18	80	20.3	32	12.0	4	* 155526	* 155527
12	1.00	18	80	20.0	32	12.0	4	118664	135007
12	1.25	18	80	20.0	32	12.0	4	* 118666	* 135267
12	1.50	18	80	21.0	32	12.0	4	118669	135181
12	2.00	18	80	20.0	32	12.0	4	118673	135269
16	1.00	24	90	25.0	42	16.0	4	118680	135270
16	1.50	24	90	25.5	42	16.0	4	118682	116017
16	2.00	24	90	26.0	42	16.0	4	118684	135271
16	2.50	24	90	25.0	42	16.0	4	118689	135272
16	3.00	24	90	27.0	42	16.0	4	158760	150564
20	1.00	30	105	33.0	52	20.0	5	135273	135274
20	1.50	30	105	33.0	52	20.0	5	118694	135275
20	2.00	30	105	34.0	52	20.0	5	116338	135276
20	2.50	30	105	32.5	52	20.0	5	* 135277	* 135278
20	3.00	30	105	33.0	52	20.0	5	118699	135279
20	3.50	30	105	38.5	55	20.0	5	144195	144065

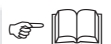

GFM

GFM6260



GFM6260VS



GFM6260

GFM6260VS

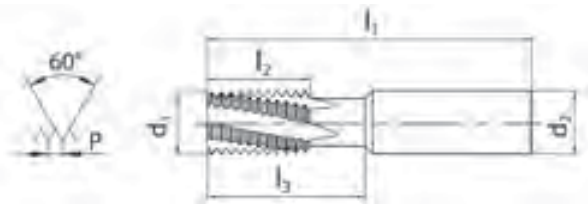

d ₁ mm	P TPI	Ø" D ₁ ≥ UN	l ₁ mm	l ₂ mm	l ₃ mm	d ₂ mm	⊕	ID	ID
10	24	1/2	70	15.9	26	10	4	135288	135289
12	24	3/4	80	20.1	32	12	4	135290	135291
12	20	3/4	80	20.3	32	12	4	135292	135293
12	18	3/4	80	19.8	32	12	4	135394	135295
12	16	3/4	80	20.6	32	12	4	135296	135297
12	10	3/4	80	20.3	32	12	4	150963	155494
16	24	1	90	25.4	42	16	4	135298	135299
16	20	1	90	25.4	42	16	4	135300	135301
16	18	1	90	25.4	42	16	4	135302	135303
16	16	1	90	25.4	42	16	4	135304	135305
16	14	1	90	25.4	42	16	4	135306	135307
16	12	1	90	25.4	42	16	4	135308	135309
16	9	1	90	25.4	42	16	4	150964	155495
16	8	1	90	25.4	42	16	4	150965	155496
20	24	1 1/4	105	32.8	52	20	5	135310	135311
20	20	1 1/4	105	33.0	52	20	5	135312	135313
20	18	1 1/4	105	32.5	52	20	5	135314	135315
20	16	1 1/4	105	33.4	52	20	5	118697	135316
20	14	1 1/4	105	32.7	52	20	5	136317	135318
20	12	1 1/4	105	31.8	52	20	5	135319	135320
20	8	1 1/4	105	31.8	52	20	5	135321	135322
20	7	1 1/4	105	32.7	52	20	5	150962	155497



262

GFM

GFM6260



GFM6260VS



GFM6260



GFM6260

GFM6260VS

GFM6260

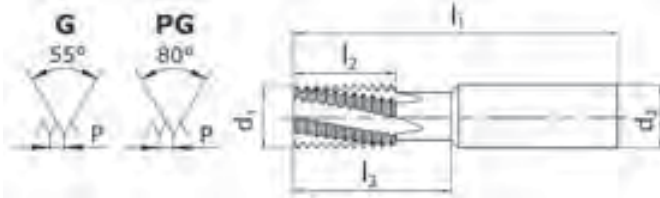

d ₁ mm	P TPI	Ø" D ₁ G	l ₁ mm	l ₂ mm	l ₃ mm	d ₂ mm	
10	19	1/4 - 3/8	70	16.0	26	10	4
16	14	1/2 - 7/8	90	25.4	42	16	4
20	11	≥ 1	105	32.3	52	20	5

ID

ID

118655

135280

118678

135281

118691

135282

d ₁ mm	P TPI	Ø" D ₁ PG	l ₁ mm	l ₂ mm	l ₃ mm	d ₂ mm	
10	20	7	70	16.0	26	10	4
12	18	9 - 16	80	20.0	32	12	4
16	16	21 - 48	90	25.0	42	16	4

ID

116177

135284

135286

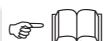

NPT, NPTF

ANSI B1.20.1
ANSI B1.20.3

VHM
CAR



DIN 6535 HA

HB
HE

sur demande
auf Anfrage
on request
su richiesta
sobre pedido

GFM

GFM6260

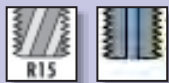

GFM6260VS



GFM6260

GFM6260VS

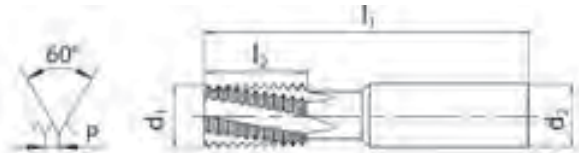

d ₁ mm	P TPI	Ø" D ₁ ≥ NPT	l ₁ mm	l ₂ mm	d ₂ mm	
14.5	14	1/2	90	19.1	16	4
18.5	11.5	1	90	23.2	20	5

ID	ID
135323	135324
135325	135326

d ₁ mm	P TPI	Ø" D ₁ ≥ NPTF	l ₁ mm	l ₂ mm	d ₂ mm	
14.5	14	1/2	90	19.1	16	4
18.5	11.5	1	90	23.2	20	5

ID	ID
135327	135328
135329	135330

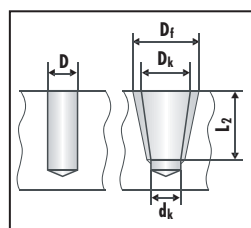

Ø D ₁	Отверстие под резьбу Średnica otworu			Фрезерование Frezowanie	
	D	d _k	D _k	D _f	L ₂
1/2	17.9	17.5	18.42	20.37	13.57
3/4	23.2	22.8	23.76	25.69	14.05
1	29.1	28.7	29.81	32.18	16.79
1 1/4	37.7	37.4	38.57	40.90	17.30
1 1/2	44.0	43.5	44.64	49.67	17.30
2	56.0	55.5	56.67	58.99	17.70



262

BGF

BGF6760



BGF6760VS



BGF6760

BGF6760VS

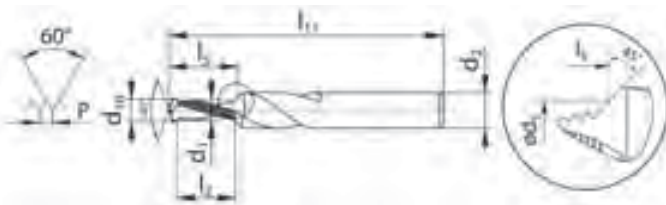

$\varnothing D_1$ M	P mm	d_1 mm	d_{10} mm	l_{11} mm	l_2 mm	l_3 mm	d_s mm	d_2 mm		ID	ID
4	0.70	3.10	3.30	48	5.6	7.4	4.1	6	2	153400	153415
5	0.80	4.00	4.20	54	7.2	9.4	5.1	6	2	153401	153416
6	1.00	4.75	5.00	62	9.0	11.7	6.2	8	2	153402	153417
8	1.25	6.50	6.75	74	11.2	14.6	8.2	10	2	151911	153418
10	1.50	8.25	8.50	80	14.9	19.1	10.3	12	2	153403	151442
12	1.75	9.95	10.25	90	17.4	22.1	12.3	14	2	153404	153419
14	2.00	11.60	12.00	102	19.9	25.1	14.4	16	2	153405	153420
16	2.00	13.60	14.00	102	23.9	29.5	16.4	18	2	153406	153421

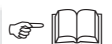

BGF

BGF6765

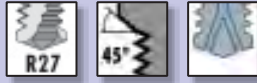

BGF6765VS



BGF6766



BGF6766VS

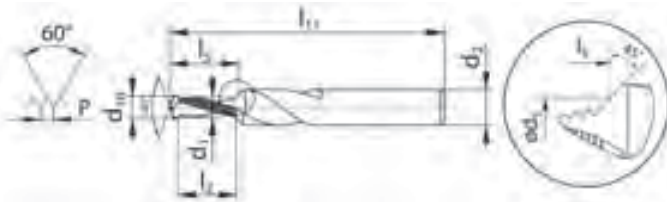

BGF6765

BGF6765VS

BGF6766

BGF6766VS



$\varnothing D_1$ M	P mm	d_1 mm	d_{10} mm	l_{11} mm	l_2 mm	l_s mm	d_s mm	d_2 mm	
4	0.70	3.10	3.30	48	7.7	9.5	4.1	6	2
5	0.80	4.00	4.20	54	9.6	11.8	5.1	6	2
6	1.00	4.75	5.00	62	12.0	14.7	6.2	8	2
8	1.25	6.50	6.75	74	15.0	18.4	8.2	10	2
10	1.50	8.25	8.50	80	19.4	23.6	10.3	12	2
12	1.75	9.95	10.25	90	22.7	27.3	12.3	14	2
14	2.00	11.60	12.00	102	27.9	33.1	14.4	16	2
16	2.00	13.60	14.00	102	31.9	37.5	16.4	18	2

ID

ID

153430	153442
151305	151306
150933	151776
153431	150588
153432	150589
153433	150927
153434	153443
153435	151324

$\varnothing D_1$ M	P mm	d_1 mm	d_{10} mm	l_{11} mm	l_2 mm	l_s mm	d_s mm	d_2 mm	
6	1.00	4.75	5.00	62	15.0	17.7	6.2	8	2
8	1.25	6.50	6.75	74	20.0	23.4	8.2	10	2
10	1.50	8.25	8.50	80	23.9	28.1	10.3	12	2
12	1.75	9.95	10.25	90	29.7	34.3	12.3	14	2
14	2.00	11.60	12.00	102	35.9	41.1	14.4	16	2
16	2.00	13.60	14.00	102	39.9	45.5	16.4	18	2

ID

ID

153451	153467
153452	153468
153453	153469
153454	153470
153455	153471
153456	153472



262

BGF

BGF6865

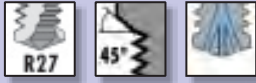

BGF6865VS



BGF6866



BGF6866VS

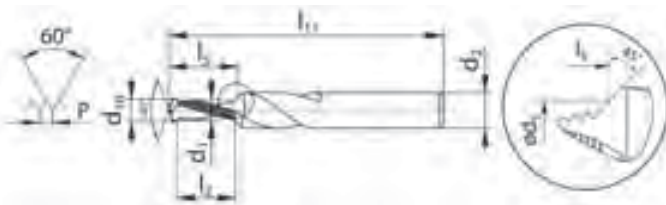

BGF6865

BGF6865VS

BGF6866

BGF6866VS



$\varnothing D_1$ M	P mm	d_1 mm	d_{10} mm	l_{11} mm	l_2 mm	l_3 mm	d_s mm	d_2 mm		ID	ID
6	1.00	4.75	5.00	62	12.0	14.7	6.2	8	3	153577	153589
8	1.25	6.50	6.75	74	14.9	18.4	8.2	10	3	153578	153590
10	1.50	8.25	8.50	80	19.4	23.6	10.3	12	3	153579	153591
12	1.75	9.95	10.25	90	22.7	27.3	12.3	14	3	* 153580	* 153592
14	2.00	11.60	12.00	102	27.9	33.1	14.4	16	3	* 153581	* 153593
16	2.00	13.60	14.00	102	31.9	37.5	16.4	18	3	* 153582	* 153594

$\varnothing D_1$ M	P mm	d_1 mm	d_{10} mm	l_{11} mm	l_2 mm	l_3 mm	d_s mm	d_2 mm		ID	ID
6	1.00	4.75	5.00	62	15.0	17.7	6.2	8	3	153601	153613
8	1.25	6.50	6.75	74	20.0	23.4	8.2	10	3	153602	153614
10	1.50	8.25	8.50	80	23.9	28.1	10.3	12	3	153603	153615
12	1.75	9.95	10.25	90	29.7	34.3	12.3	14	3	* 153604	* 153616
14	2.00	11.60	12.00	102	35.9	41.1	14.4	16	3	* 153605	* 153617
16	2.00	13.60	14.00	102	39.9	45.5	16.4	18	3	* 153606	* 153618

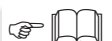

BGF

BGF6760

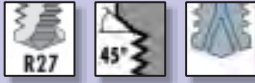

BGF6760VS



BGF6765



BGF6765VS

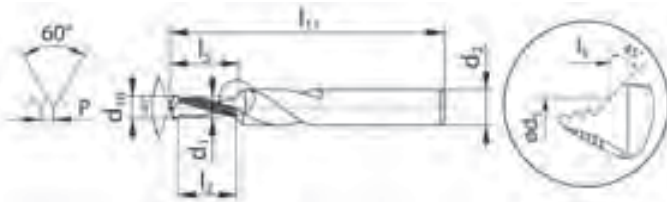

BGF6760



BGF6760VS



BGF6765



BGF6765VS



∅ D ₁ MF	P mm	d ₁ mm	d ₁₀ mm	l ₁₁ mm	l ₂ mm	l ₃ mm	d _s mm	d ₂ mm	
6	0.75	5.00	5.25	62	9.0	11.4	6.2	8	2
8	1.00	6.75	7.00	74	12.0	15.0	8.2	10	2
10	1.00	8.75	9.00	80	15.0	18.5	10.3	12	2
12	1.00	10.70	11.00	90	18.0	21.9	12.3	14	2
12	1.50	10.20	10.50	90	17.9	22.5	12.3	14	2
14	1.50	12.10	12.50	102	20.9	26.0	14.4	16	2
16	1.50	14.10	14.50	102	23.9	29.4	16.4	18	2

ID	ID
153759	153780
153761	153782
153762	153783
153765	153786
153764	153785
153766	153787
153767	153788

∅ D ₁ MF	P mm	d ₁ mm	d ₁₀ mm	l ₁₁ mm	l ₂ mm	l ₃ mm	d _s mm	d ₂ mm	
6	0.75	5.00	5.25	62	9.0	11.4	6.2	8	2
8	1.00	6.75	7.00	74	12.0	15.0	8.2	10	2
10	1.00	8.75	9.00	80	15.0	18.5	10.3	12	2
12	1.00	10.70	11.00	90	18.0	21.9	12.3	14	2
12	1.50	10.20	10.50	90	17.9	22.5	12.3	14	2
14	1.50	12.10	12.50	102	20.9	26.0	14.4	16	2
16	1.50	14.10	14.50	102	23.9	29.4	16.4	18	2

ID	ID
153802	153824
153804	153826
153805	153827
153808	153830
153807	153829
153809	153831
153810	153832



262

СКОРОСТИ РЕЗАНИЯ И ЗНАЧЕНИЯ ПОДАЧИ PRĘDKOŚCI SKRAWANIA I POSUWY

Таблица DC для резьбовых фрез и сверл-фрез
Tabela DC dla frezów do gwintów oraz wiertło-frezów

Группы материалов Grupy materiałowe	Описание материалов Примеры для групп применения, стр. 5.	Оznaczenie materiału Примеры для групп zastosowań, strona 6.	Твердость Twardość (HB)	Предел прочности Wytrzymałość на растяжение Rm (N/mm ²)
10 Стали Stale	11 Автоматные стали	Stale szybkoobrotowe	< 200	< 700
	12 Структурные/цементуемые стали	Stale konstrukcyjne/nawęglane	< 200	< 700
	13 Углеродистые стали	Stale węglowe	< 300	< 1000
	14 Легированные <850 N/mm ²	Stale stopowe <850 N/mm ²	< 250	< 850
	15 Легированные стали >850 - <1150 N/mm ²	Stale stopowe >850 - <1150 N/mm ²	> 250	> 850
	16 Высокопрочные легированные стали	Stale stopowe o dużej wytrzymałości	> 250	> 850
	* Высокопрочные легированные стали 55 - 63 HRC	Stale stopowe o dużej wytrzymałości 55 - 63 HRC	> 560	> 2000
20 Нержавеющие стали Stale nierdzewne	21 Легкообрабатываемые нержавеющие стали	Stale automatowe nierdzewne	< 250	< 850
	22 Аустенитные нержавеющие стали	Austeniczne stale nierdzewne	< 250	< 850
	23 Ферритные и мартенситные <850 N/mm ²	Stale ferrytowe i martenzytowe <850 N/mm ²	< 250	< 850
	24 Ферритные и мартенситные >850 - <1150 N/mm ²	Stale ferrytowe i martenzytowe >850 - <1150 N/mm ²	> 250	> 850
30 Чугун Żeliwo szare	31 Чугун	Żeliwo szare	< 250	< 850
	32 Ковкий и высокопрочный чугун	Żeliwo sferoidalne	< 250	< 850
40 Титан Tytan	41 Чистый титан	Чистый титан	< 250	< 850
	42 Титановые сплавы	Сплав титана	> 250	> 850
50 Никель Nikiel	51 Никелевые сплавы 1 <850 N/mm ²	Сплав никеля 1 <850 N/mm ²	< 250	< 850
	52 Никелевые сплавы 2 >850 - <1150 N/mm ²	Сплав никеля 2 >850 - <1150 N/mm ²	> 250	> 850
	53 Никелевые сплавы 3 >1150 - ≤1600 N/mm ²	Сплав никеля 3 >1150 - ≤1600 N/mm ²	> 340	> 1150
60 Медь Miedź	61 Чистая медь (электротехническая)	Чистая медь (медь электролитическая)	< 120	< 400
	62 Короткостружечная латунь	Мосиадз z krótkim wiórem, brąz fosforowy, brąz armatni	< 200	< 700
	63 Длинностружечная латунь	Мосиадз z długim wiórem	< 200	< 700
70 Алюминий, Магний Aluminium, Magnez	71 Нелегированный алюминий	Алюминий нестоповый	< 100	< 350
	72 Алюминий Si < 1.5 %	Сплав алюминия Si < 1.5 %	< 150	< 500
	73 Алюминий Si > 1.5 % - < 10 %	Сплав алюминия Si > 1.5 % - < 10 %	< 120	< 400
	74 Алюминий Si > 10 %, сплавы магния	Сплав алюминия Si > 10 %, Сплав магния	< 120	< 400
80 Сложные пластики, компаннды Творыва sztuczne	81 Термопластики	Творыва sztuczne - термопласты	-	-
	82 Дуропластики	Творыва sztuczne - duroпласты	-	-
	83 Стеклопластики	Творыва sztuczne wzmacniane włóknem szklanym	-	-

* Резьбовая фреза тип GFH

Фрез до gwintu. Тип GFH

Подачи при фрезеровании резьбы

Подача

$$V_{fk} = f_z \times Z \times n$$

Значение подачи центра инструмента $V_{fm} = \frac{V_{fk} \times (\text{Номинальный диаметр резьбы} - \text{Диаметр резьбовой фрезы})}{\text{Номинальный диаметр резьбы}}$

Номинальный диаметр резьбы

На станках с ЧПУ, которые сами не вычисляют значение подачи для центра инструмента, это значение должно быть задано.

Posuwу przy frezowaniu gwintu

Вартоść posuwу

$$V_{fk} = f_z \times Z \times n$$

Posuw liczony dla środка narzędzia $V_{fm} = \frac{V_{fk} \times (\text{Gwint nominalny } \varnothing - \text{Średnica freza } \varnothing)}{\text{Gwint nominalny } \varnothing}$

Gwint nominalny \varnothing

Na maszynach CNC, które nie obliczają same posuwу, wartość „środek narzędzia V_{fm} ” musi być określona

Резьбовая фреза Frezy do gwintów

Vc (m/min)		Значение подачи fz (мм/Зahn) Wartość posuwu fz (mm/ząb)
Стандартный Standard	С покрытием VS Powlekany „VS“	
50 ÷ 100	80 ÷ 150	0.04 ÷ 0.15
40 ÷ 80	60 ÷ 120	0.04 ÷ 0.15
40 ÷ 80	60 ÷ 120	0.02 ÷ 0.10
40 ÷ 80	60 ÷ 120	0.02 ÷ 0.10
30 ÷ 60	50 ÷ 90	0.02 ÷ 0.08
20 ÷ 40	30 ÷ 60	0.01 ÷ 0.05
10 ÷ 30	20 ÷ 40	0.005 ÷ 0.02
30 ÷ 60	50 ÷ 90	0.02 ÷ 0.10
20 ÷ 40	30 ÷ 60	0.01 ÷ 0.05
30 ÷ 60	50 ÷ 90	0.02 ÷ 0.08
20 ÷ 40	30 ÷ 60	0.01 ÷ 0.05
50 ÷ 100	80 ÷ 150	0.05 ÷ 0.15
50 ÷ 80	80 ÷ 120	0.02 ÷ 0.10
40 ÷ 70	60 ÷ 100	0.02 ÷ 0.08
20 ÷ 40	30 ÷ 60	0.01 ÷ 0.05
20 ÷ 40	30 ÷ 60	0.02 ÷ 0.08
20 ÷ 40	30 ÷ 60	0.02 ÷ 0.08
10 ÷ 20	20 ÷ 30	0.005 ÷ 0.02
150 ÷ 200	200 ÷ 250	0.05 ÷ 0.15
150 ÷ 200	200 ÷ 250	0.05 ÷ 0.15
150 ÷ 200	200 ÷ 250	0.05 ÷ 0.15
100 ÷ 250	150 ÷ 300	0.05 ÷ 0.20
100 ÷ 250	150 ÷ 300	0.05 ÷ 0.20
100 ÷ 250	150 ÷ 300	0.05 ÷ 0.20
100 ÷ 250	150 ÷ 300	0.05 ÷ 0.20
100 ÷ 250	150 ÷ 300	0.05 ÷ 0.15
100 ÷ 200	150 ÷ 300	0.05 ÷ 0.20
50 ÷ 100	80 ÷ 150	0.04 ÷ 0.15
60 ÷ 80	80 ÷ 120	0.04 ÷ 0.15

Фрезы-сверла Wiertło-frezy

Vc (m/min)		Сверление f (мм/об.) Wiercenie f (mm/obr.)	Фрезерование fz (мм/зуб) Frezowanie fz (mm/ząb)
Стандартный Standard	С покрытием VS Powlekany „VS“		
50 ÷ 100	80 ÷ 150	0.1 ÷ 0.3	0.05 ÷ 0.15
50 ÷ 80	80 ÷ 120	0.1 ÷ 0.2	0.02 ÷ 0.10
100 ÷ 250	150 ÷ 300	0.1 ÷ 0.4	0.05 ÷ 0.20
100 ÷ 250	150 ÷ 300	0.1 ÷ 0.4	0.05 ÷ 0.20
100 ÷ 250	150 ÷ 300	0.1 ÷ 0.4	0.05 ÷ 0.20
100 ÷ 250	150 ÷ 300	0.1 ÷ 0.4	0.05 ÷ 0.20
100 ÷ 200	150 ÷ 250	0.1 ÷ 0.3	0.05 ÷ 0.15

Значения носят рекомендательный характер. Zalecane wartości.

Технические примечания

△ При обработке длинностружечных материалов могут потребоваться одно или более промежуточные удаления стружки.

































△ Перед использованием сверл-фрез типа BGF по материалам, для которых не даны режимы резания, запрашивайте **DC SWISS SA**.







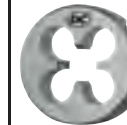

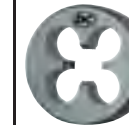
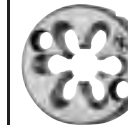
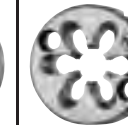



Uwagi techniczne

△ Podczas obróbki materiałów z długim wiórem może być wymagana jedna lub więcej operacji usuwania wiórow.

















△ Prosimy o kontakt z **DC SWISS** przed wykorzystaniem narzędzi typu BGF w materiałach dla których nie podano parametrów skrawania.













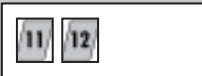

Указатель – Круглые плашки, плашки для Швейцарских автоматов, шестигранные и выгнутые
Skorowidz – Narzynki okrągłe, dla automatyki szwajcarskiej, forma: sześciokątna oraz „dzwonu“

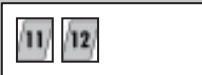
		N		MS	Z		N	MS
Характеристики Cechy charakterystyczne		  	    ≥ 0.3	    ≥ 0.3	    ≥ 0.2 	    ≥ 0.2 	    ≥ 0.3	    ≥ 0.3
								
		N5110	N5120	MS5120	Z5120	Z5120LL	N5220	MS5220
M 6g	DIN 13	228	228		229	229	242	242
M 6e	DIN 13	228	228				242	
M 6g LH	DIN 13	228	228					
MF 6g	DIN 13	230	230-232		230-231		243	
MF 6e	DIN 13		230-231					
MF 6g LH	DIN 13		230-232					
UNC	ANSI B1.1	233	233					
UNF	ANSI B1.1	234	234					
UNEF	ANSI B1.1		235					
UN	ANSI B1.1		235					
UNS	ANSI B1.1		235					
G (BSP)	DIN ISO 228	236	236	237	237			
G (BSP) LH	DIN ISO 228		236					
G (BSP) -0.1 mm	DIN ISO 228			237				
R (BSPT)	DIN EN 10226		238					
NPT	ANSI B1.20.1		239					
NPTF	ANSI B1.20.3		239					
PG	DIN 40430		240					
TR	DIN 103		240					
W (BSW)	BS 84	241	241					
W (BSW) LH	BS 84		241					

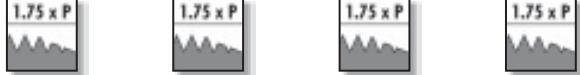
Z	N	
   	 	  
		
Z5220	N5310	N5420
242	244	247
	245	
	246	
	246	

Пиктограммы – Piktogramy

-  Быстрорежущая сталь
HSS
-  Быстрорежущая сталь с кобальтом
HSSE
-  1.25 Заходная часть 1,25 нитки
1.25 zwoi wprowadzających
-  1.75 Заходная часть 1,75 нитки
1.75 zwoi wprowadzających
-  2 Заходная часть 2 нитки
2 zwoje wprowadzające
-  Schälanschnitt ab \varnothing 3 mm
Narzynka jednostronna od \varnothing 3 mm
-  Подчищающая фаска с двух сторон на диаметрах \varnothing > 3 mm
Narzynka dwustronna od \varnothing > 3 mm
-  Количество режущих кромок
Ilość ostrzy
-  Диаметр прутка под плашку
Średnice wałków
-  Азотированные ($d_1 \geq 3$ mm, $P \geq 0.5$ mm)
Azotowany ($d_1 \geq 3$ mm, $P \geq 0.5$ mm)
-  С 2 предохранительными отверстиями
Narzynka z 2 otworami zabezpieczającymi
-  Класс точности 6g
Tolerancja 6g
-  Класс точности 6e
Tolerancja 6e
-  Класс точности Средний
Tolerancja „Średniej Klasy“
-  Класс точности A
Tolerancja A
-  Коническая резьба 1:16 (NPT - NPTF - R)
Gwint stożkowy 1:16 (NPT - NPTF - R)
-  Левая резьба
Gwint lewy

								N5110	N5120	N5120 LH	N5120
<p>N5110 </p> <p>N5120  </p> <p>N5120 LH  LH </p> <p>N5120  </p>											
											
											
∅ d ₁ M	P mm	d ₂ mm	l ₁ mm	 6g	 LH / 6e	 6g	 6e	ID	ID	ID	ID 6g - mm
1	0.25	16.0	5.0	3		0.97		103851			
1.1	0.25	16.0	5.0	3		1.07		124659			
1.2	0.25	16.0	5.0	3		1.17		103852			
1.4	0.30	16.0	5.0	3		1.36		103853			
1.6	0.35	16.0	5.0	3		1.54		103855			
1.7	0.35	16.0	5.0	3		1.64		103856			
1.8	0.35	16.0	5.0	3		1.74		103857			
*2	0.40	16.0	5.0		4	1.93	1.90	103864		* 103865	* 104018 0.030
2.2	0.45	16.0	5.0	3		2.13		103867			
*2.3	0.40	16.0	5.0	3	4	2.23		103869			
*2.5	0.45	16.0	5.0	3	4	2.43	2.40	103872		* 103873	
*2.6	0.45	16.0	5.0	3	4	2.53		103876		* 103877	
3	0.50	20.0	5.0	3	4	2.92	2.90	103879	104067	104068	104066 0.030
3.5	0.60	20.0	5.0	3	4	3.41	3.38	103880	104071	104072	* 104070 0.030
4	0.70	20.0	5.0	3	4	3.91	3.87	103881	104114	104115	104113 0.035
4.5	0.75	20.0	7.0	4		4.41		103882	104117		
5	0.80	20.0	7.0	4	4	4.90	4.87	103883	104146	104147	104145 0.035
5.5	0.90	20.0	7.0	4		5.40		103884			
6	1.00	20.0	7.0	4	4	5.88	5.85	103885	104165	104166	104164 0.035
7	1.00	25.0	9.0	4	4	6.88		103886	104174	104175	
8	1.25	25.0	9.0	4	4	7.87	7.83	103887	104186	104187	104185 0.035
9	1.25	25.0	9.0	4		8.87		103888	104191		
10	1.50	30.0	11.0	4	4	9.85	9.82	103858	103953	103954	103952 0.035
12	1.75	38.0	14.0	4	4	11.83	11.80	103859	103973	103974	103972 0.035
14	2.00	38.0	14.0	4	4	13.82		103860	103989	103990	
16	2.00	45.0	18.0	4	4	15.82	15.79	103861	104003	104004	104002 0.035
18	2.50	45.0	18.0	5	5	17.79		103862	104015		
20	2.50	45.0	18.0	5	5	19.79		103878	104028	104029	
22	2.50	55.0	22.0	5	5	21.79			104035	* 104036	
24	3.00	55.0	22.0	5	5	23.76			104043	104044	
27	3.00	65.0	25.0	5	5	26.76			104058	* 104059	
30	3.50	65.0	25.0	5	5	29.73			104079	104080	
33	3.50	65.0	25.0	6		32.73			104089		
36	4.00	65.0	25.0	7		35.70			104100		
45	4.50	90.0	36.0	7		44.69				* 104132	
52	5.00	90.0	36.0	7		51.66				* 104155	

* N5110 / N5110 LH

≤ M1.4

6h

Z5120				Z5120	Z5120 LL		
Z5120 LL							

$\varnothing d_1$ M	P mm	d_2 mm	l_1 mm				ID	ID
				Z5120	Z5120LL	$\rightarrow 6g \leftarrow$		
2	0.40	16.0	3.5	4	4	1.93	125269	105115
2.5	0.45	16.0	5.0	4	4	2.43	104779	105116
2.6	0.45	16.0	5.0	4		2.53	104780	
3	0.50	20.0	5.0	4	5	2.92	104788	105117
3.5	0.60	20.0	5.0	4		3.41	104789	
4	0.70	20.0	5.0	4	5	3.91	104790	105118
5	0.80	20.0	7.0	4	5	4.90	104792	105119
6	1.00	20.0	7.0	4	5	5.88	104795	105120
7	1.00	25.0	9.0	4		6.88	111424	
8	1.25	25.0	9.0	5	6	7.87	104798	105121
10	1.50	30.0	11.0	5	6	9.85	104767	105122
12	1.75	38.0	14.0	5	6	11.83	104770	105123
14	2.00	38.0	14.0	5		13.82	104773	
16	2.00	45.0	18.0	5		15.82	104776	
18	2.50	45.0	18.0	5		17.79	104778	
20	2.50	45.0	18.0	5		19.79	104783	
22	2.50	55.0	22.0	6		21.79	104785	
24	3.00	55.0	22.0	6		23.76	104787	























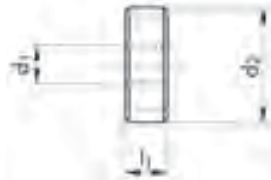











								N5120	N5120 LH	N5120	Z5120	
N5120												
N5120 LH												
N5120												
Z5120												
								6g	6g	6e	6g	
$\varnothing d_1$ MF	P mm	d_2 mm	l_1 mm	\oplus N	\oplus Z	$\rightarrow 6g \leftarrow$	$\rightarrow 6e \leftarrow$	ID	ID	ID	6g - mm	ID
* 2	0.25	16.0	5.0	4		1.93		103863				
* 2.5	0.35	16.0	5.0	4		2.44		103871				
3	0.35	20.0	5.0	4		2.94		104064				
3.5	0.35	20.0	5.0	4		3.44		104069				
4	0.35	20.0	5.0	4		3.94		104108				
4	0.50	20.0	5.0	4		3.93	3.90	104110			* 104109	0.030
4.5	0.50	20.0	5.0	4		4.43		104116				
5	0.35	20.0	5.0	4		4.94		* 104139				
5	0.50	20.0	5.0	4	4	4.93	4.90	104141	104142	104140	0.030	104791
5	0.75	20.0	7.0	4		4.91		104143				
5.5	0.50	20.0	5.0	4		5.43		104148				
6	0.50	20.0	5.0	4		5.93	5.90	104159	104160	* 104158	0.030	104793
6	0.75	20.0	7.0	4	4	5.91	5.87	104162	104163			104794
7	0.50	25.0	9.0	4	4	6.93		104169				
7	0.75	25.0	9.0	4		6.90	6.87	104171		* 104170	0.035	
8	0.50	25.0	9.0	5		7.93	7.90	104177		* 104176	0.030	
8	0.75	25.0	9.0	4	4	7.90	7.87	104180		* 104179	0.035	104796
8	1.00	25.0	9.0	4	4	7.88	7.85	104183	104184	104182	0.035	104797
9	0.50	25.0	9.0	5		8.93		104188				
9	0.75	25.0	9.0	5		8.90		104189				
9	1.00	25.0	9.0	5		8.88		104190				
10	0.50	30.0	11.0	5		9.93		103942				
10	0.75	30.0	11.0	5	5	9.90	9.87	103945		* 103944	0.035	104765
10	1.00	30.0	11.0	5	5	9.88	9.85	103948	103949	103947	0.035	104766
10	1.25	30.0	11.0	4		9.86		103950	103951			
11	0.75	30.0	11.0	5		10.91		103956				
11	1.00	30.0	11.0	5		10.88		103957				
11	1.25	30.0	11.0	5		10.87		103958				
12	0.50	38.0	10.0	5		11.93		103960				
12	0.75	38.0	10.0	5		11.91	11.87	103962		* 103961	0.035	
12	1.00	38.0	10.0	5	5	11.88	11.85	103965	103966	103964	0.035	104768
12	1.25	38.0	10.0	4		11.86		103967	103968			
12	1.50	38.0	10.0	4	5	11.85	11.82	103970	103971			104769
13	1.00	38.0	10.0	5		12.88		103976				





* N5110

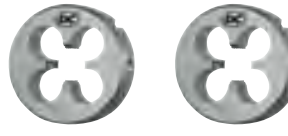
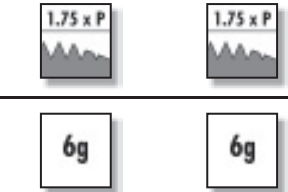





P 0.25



6h

N5120								N5120		N5120 LH		N5120		Z5120	
  															
															
  															
∅ d ₁ MF	P mm	d ₂ mm	l ₁ mm	 N	 Z	 6g	 6e	ID	ID	ID	6g - mm	ID			
14	0.50	38.0	10.0	5		13.93		103977							
14	0.75	38.0	10.0	5		13.91		103979							
14	1.00	38.0	10.0	5	5	13.88		103981	103982			104771			
14	1.25	38.0	10.0	5		13.86		103983	* 103984						
14	1.50	38.0	10.0	5	5	13.85	18.32	103986	103987			104772			
15	1.00	38.0	10.0	5		14.88		103991							
15	1.50	38.0	10.0	5		14.85		103992							
16	1.00	45.0	14.0	5	5	15.88	15.85	103996	103997	* 103995	0.035	104774			
16	1.25	45.0	14.0	5		15.87		103998							
16	1.50	45.0	14.0	5	5	15.85	15.82	104000	104001	* 103999	0.035	104775			
17	1.00	45.0	14.0	5		16.88		104005							
18	1.00	45.0	14.0	5		17.88		104008							
18	1.25	45.0	14.0	5		17.87		* 104010							
18	1.50	45.0	14.0	5	5	17.85		104011	104012			* 104777			
18	2.00	45.0	14.0	5		17.82		104013	* 104014						
19	1.00	45.0	14.0	6		18.88		104017							
20	0.75	45.0	14.0	6		19.91		* 111385							
20	1.00	45.0	14.0	6	6	19.88		104021	104022			104781			
20	1.50	45.0	14.0	6	6	19.85		104024	104025			104782			
20	2.00	45.0	14.0	6		19.82		104026	* 104027						
21	1.00	45.0	14.0	7		20.88		111386							
22	1.00	55.0	16.0	6		21.88		104030							
22	1.50	55.0	16.0	6	6	21.85		104032	* 104033			* 104784			
22	2.00	55.0	16.0	5		21.82		104034							
23	1.00	55.0	16.0	6		22.88		121704							
24	1.00	55.0	16.0	6		23.88		104037	* 104038						
24	1.50	55.0	16.0	6	6	23.85		104039				* 104786			
24	2.00	55.0	16.0	6		23.82		104041	104042						
25	1.00	55.0	16.0	6		24.88		104045							
25	1.50	55.0	16.0	6		24.85		104046	* 104047						
26	1.00	55.0	16.0	7		25.88		104049							
26	1.50	55.0	16.0	6		25.85		104050	* 104051						
26	2.00	55.0	16.0	6		25.82		104052							
27	1.00	65.0	18.0	6		26.88		104053							
27	1.50	65.0	18.0	6		26.85		104054	* 104055						
27	2.00	65.0	18.0	6		26.82		104056							

<div style="display: flex; justify-content: space-between;"> <div style="width: 45%;"> <p>N5120 </p> <p>N5120 LH  LH</p> </div> <div style="width: 45%;"> <p> </p> <p> </p> </div> </div>							N5120	N5120 LH		
										
										
$\varnothing d_1$ MF	P mm	d_2 mm	l_1 mm	\oplus	$\rightarrow 6g \leftarrow$	ID	ID			
28	1.00	65.0	18.0	6	27.88	104060				
28	1.50	65.0	18.0	6	27.85	104061				
30	1.00	65.0	18.0	7	29.88	104073				
30	1.50	65.0	18.0	6	29.85	104074	* 104075			
30	2.00	65.0	18.0	6	29.82	104076	* 104077			
32	1.00	65.0	18.0	7	31.88	104081				
32	1.50	65.0	18.0	7	31.85	104082	* 104083			
32	2.00	65.0	18.0	7	31.82	104084				
33	1.50	65.0	18.0	7	32.85	104085				
33	2.00	65.0	18.0	7	32.82	104086				
33	3.00	65.0	25.0	7	32.76	* 104088				
34	1.50	65.0	18.0	7	33.85	104091				
35	1.50	65.0	18.0	8	34.85	104092	* 104093			
36	1.50	65.0	18.0	8	35.85	104095	* 104096			
36	2.00	65.0	18.0	8	35.82	104097	* 104098			
36	3.00	65.0	25.0	7	35.76	104099				
38	1.50	75.0	20.0	7	37.85	104101	* 104102			
38	2.00	75.0	20.0	7	37.82	104103				
39	1.50	75.0	20.0	7	38.85	104104				
39	2.00	75.0	20.0	7	38.82	104105				
40	1.50	75.0	20.0	8	39.85	104118	* 104119			
40	2.00	75.0	20.0	7	39.82	104120				
42	1.50	75.0	20.0	8	41.85	104122	* 104123			
42	2.00	75.0	20.0	8	41.82	* 104124				
42	3.00	75.0	20.0	8	41.76	104125				
45	1.50	90.0	22.0	7	44.85	104127	* 104128			
45	2.00	90.0	22.0	7	44.82	104129				
48	1.50	90.0	22.0	8	47.85	104133	* 104134			
48	2.00	90.0	22.0	8	47.82	104135				
48	3.00	90.0	22.0	7	47.76	104137				
50	1.50	90.0	22.0	8	49.85	104150				
52	1.50	90.0	22.0	9	51.85	104151				
52	2.00	90.0	22.0	9	51.82	104152				
56	1.50	105.0	22.0	8	55.85	* 104157				
60	1.50	105.0	22.0	9	59.85	* 104167				
60	2.00	105.0	22.0	9	59.82	104168				

N5110 N5120			N5110	N5120		
						

$\varnothing'' d_1$ UNC	P TPI	d_2 mm	l_1 mm			ID	ID
1	64	16.0	5.0	3	1.79	103893	
2	56	16.0	5.0	4	2.12	103894	
3	48	16.0	5.0	4	2.44	103895	
4	40	16.0	5.0	4	2.76	103896	
5	40	20.0	5.0	4	3.09		104263
6	32	20.0	7.0	4	3.41		104266
8	32	20.0	7.0	4	4.07		104269
10	24	20.0	7.0	4	4.71		104258
12	24	20.0	7.0	4	5.37		104259
1/4	20	20.0	7.0	4	6.22		104256
5/16	18	25.0	9.0	4	7.80		104264
3/8	16	30.0	11.0	4	9.37		104262
7/16	14	30.0	11.0	4	10.95		104267
1/2	13	38.0	14.0	4	12.52		111387
9/16	12	38.0	14.0	4	14.10		104270
5/8	11	45.0	18.0	4	15.68		104265
3/4	10	45.0	18.0	5	18.84		104261
7/8	9	55.0	22.0	5	22.00		104268
1	8	55.0	22.0	5	25.16		104257
1 1/8	7	65.0	25.0	5	28.31		* 104252
1 1/4	7	65.0	25.0	6	31.49		104251
1 1/2	6	75.0	30.0	6	37.81		104250
1 3/4	5	90.0	36.0	6	44.12		* 104253
2	4.5	90.0	36.0	7	50.45		* 104260



N5110		N5120		N5110		N5120	
Ø" d ₁ UNF	P TPI	d ₂ mm	l ₁ mm	⊕	→2A←	ID	ID
0	80	16.0	5.0	3	1.47	103897	
1	72	16.0	5.0	3	1.79	103898	
2	64	16.0	5.0	4	2.12	103899	
3	56	16.0	5.0	4	2.44	103900	
4	48	16.0	5.0	4	2.77	103901	
5	44	20.0	5.0	4	3.10		104299
6	40	20.0	5.0	4	3.42		104302
8	36	20.0	7.0	4	4.08		104305
10	32	20.0	7.0	4	4.73		104295
12	28	20.0	7.0	4	5.38		104296
1/4	28	20.0	7.0	4	6.24		104293
5/16	24	25.0	9.0	4	7.82		104300
3/8	24	30.0	11.0	4	9.41		104298
7/16	20	30.0	11.0	5	10.98		104303
1/2	20	38.0	10.0	5	12.56		104292
9/16	18	38.0	10.0	5	14.14		104306
5/8	18	45.0	14.0	5	15.73		104301
3/4	16	45.0	14.0	6	18.89		104297
7/8	14	55.0	16.0	5	22.05		104304
1	12	55.0	16.0	6	25.21		104294
1 1/8	12	65.0	18.0	6	28.38		* 104290
1 1/4	12	65.0	18.0	7	31.56		104289
1 3/8	12	65.0	18.0	8	34.73		* 104291
1 1/2	12	75.0	20.0	7	37.91		111390

UNEF, UNS, UN

ANSI B1.1











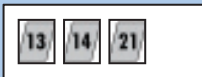





HSS









N5120						N5120
Ø" d ₁ UNEF	P TPI	d ₂ mm	l ₁ mm	⊕	→2A←	ID
12	32	20.0	7.0	4	5.39	104278
1/4	32	20.0	7.0	4	6.25	104275
5/16	32	25.0	9.0	4	7.84	104283
3/8	32	30.0	11.0	4	9.42	104282
7/16	28	30.0	11.0	5	11.00	104285
1/2	28	38.0	10.0	5	12.59	104274
9/16	24	38.0	10.0	5	14.17	104287
5/8	24	45.0	14.0	5	15.75	104284
11/16	24	45.0	14.0	5	17.34	104277
3/4	20	45.0	14.0	5	18.91	104281
13/16	20	45.0	14.0	6	20.50	104279
7/8	20	55.0	16.0	5	22.09	104286
15/16	20	55.0	16.0	6	23.67	* 104280
1	20	55.0	16.0	6	25.26	104276
1 1/8	18	65.0	18.0	6	28.43	* 104272
1 3/8	18	65.0	18.0	8	34.78	* 104273
Ø" d ₁ UNS	P TPI	d ₂ mm	l ₁ mm	⊕	→2A←	ID
1/4	40	20.0	5.0	4	6.26	104309
1/4	36	20.0	5.0	4	6.26	104308
1/4	24	20.0	7.0	4	6.23	* 116150
7/16	24	30.0	11.0	5	10.99	104311
1/2	24	38.0	10.0	5	12.58	104307
1	14	55.0	16.0	6	25.23	104310
Ø" d ₁ UN	P TPI	d ₂ mm	l ₁ mm	⊕	→2A←	ID
1 1/8	8	65.0	25.0	5	28.33	104246
1 1/4	8	65.0	25.0	6	31.51	104245
1 1/2	8	75.0	20.0	7	37.85	104244
1 3/4	8	90.0	22.0	7	44.20	104247
2	8	90.0	22.0	8	50.55	* 104249



						N5110	N5120	N5120 LH	
						1.75 x P	1.75 x P	1.75 x P	
						A	A	A	
\varnothing " d ₁	P	d ₂	l ₁	\oplus	$\rightarrow A \leftarrow$	ID	ID	ID	
G	TPI	mm	mm						
1/8	28	30.0	11.0	5	9.62		103926	* 103927	
1/4	19	38.0	10.0	5	13.03		103924	103925	
3/8	19	45.0	14.0	5	16.54	* 103848	103935	103936	
1/2	14	45.0	14.0	6	20.81		103922	103923	
5/8	14	55.0	16.0	5	22.77		103938	* 103939	
3/4	14	55.0	16.0	6	26.30		103933	103934	
7/8	14	65.0	18.0	6	30.06	* 103850	103940		
1	11	65.0	18.0	7	33.07		103928	103929	
1 1/8	11	75.0	20.0	7	37.72		103919		
1 1/4	11	75.0	20.0	8	41.73		103918		
1 3/8	11	90.0	22.0	7	44.14		* 103921		
1 1/2	11	90.0	22.0	8	47.62		103917		
1 3/4	11	90.0	22.0	9	53.57		* 103920		
2	11	105.0	22.0	9	59.43		103932		
2 1/2	11	120.0	22.0	10	74.97		103930		
3	11	130.0	25.0	8	87.67		* 103937		

Z5120		NI		Z5120	MS5120	MS5120	
MS5120							
MS5120							
							
							
$\varnothing'' d_1$ G	P TPI	d_2 mm	l_1 mm	 Z	 MS	 A	ID
1/8	28	30.0	11.0	5	5	9.62	104761 101339 * 142831
1/4	19	38.0	10.0	5	5	13.03	104760 101338 142832
3/8	19	45.0	14.0	5	5	16.54	104764 101342 119716
1/2	14	45.0	14.0	6	6	20.81	104759 101337 119243
3/4	14	55.0	16.0	6	6	26.30	104763 101341 119648
1	11	65.0	18.0	7	7	33.07	104762 101340 135186
1 1/4	11	75.0	20.0	8	8	41.73	* 142829
1 1/2	11	90.0	22.0	8	8	47.62	* 142830



<p>N5120</p>  																																																							
																																																							
																																																							
<table border="1"> <thead> <tr> <th>\varnothing'' R</th> <th>P TPI</th> <th>d_2 mm</th> <th>l_1 mm</th> <th>\oplus</th> <th>ID</th> </tr> </thead> <tbody> <tr><td>1/8</td><td>28</td><td>30.0</td><td>11.0</td><td>5</td><td>104226</td></tr> <tr><td>1/4</td><td>19</td><td>38.0</td><td>14.0</td><td>5</td><td>104225</td></tr> <tr><td>3/8</td><td>19</td><td>45.0</td><td>14.0</td><td>5</td><td>104230</td></tr> <tr><td>1/2</td><td>14</td><td>45.0</td><td>18.0</td><td>6</td><td>104224</td></tr> <tr><td>3/4</td><td>14</td><td>55.0</td><td>22.0</td><td>6</td><td>104229</td></tr> <tr><td>1</td><td>11</td><td>65.0</td><td>25.0</td><td>7</td><td>104227</td></tr> <tr><td>1 1/4</td><td>11</td><td>75.0</td><td>26.0</td><td>8</td><td>* 104223</td></tr> <tr><td>2</td><td>11</td><td>105.0</td><td>28.0</td><td>9</td><td>* 104228</td></tr> </tbody> </table>	\varnothing'' R	P TPI	d_2 mm	l_1 mm	\oplus	ID	1/8	28	30.0	11.0	5	104226	1/4	19	38.0	14.0	5	104225	3/8	19	45.0	14.0	5	104230	1/2	14	45.0	18.0	6	104224	3/4	14	55.0	22.0	6	104229	1	11	65.0	25.0	7	104227	1 1/4	11	75.0	26.0	8	* 104223	2	11	105.0	28.0	9	* 104228	
\varnothing'' R	P TPI	d_2 mm	l_1 mm	\oplus	ID																																																		
1/8	28	30.0	11.0	5	104226																																																		
1/4	19	38.0	14.0	5	104225																																																		
3/8	19	45.0	14.0	5	104230																																																		
1/2	14	45.0	18.0	6	104224																																																		
3/4	14	55.0	22.0	6	104229																																																		
1	11	65.0	25.0	7	104227																																																		
1 1/4	11	75.0	26.0	8	* 104223																																																		
2	11	105.0	28.0	9	* 104228																																																		

Размеры диаметров под резьбу R (в мм)

Wymiary wałków pod gwintny typu R (w mm)

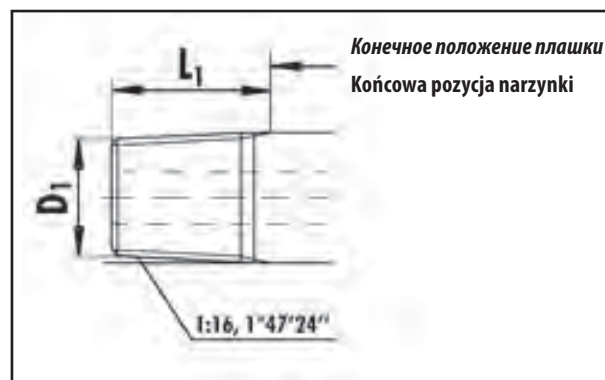

\varnothing'' R	D_1 mini mm	D_1 maxi mm	D_1 (guide line) mm	L_1 (guide line) mm
1/8	9.422	9.534	9.48	8.2
1/4	12.700	12.863	12.78	12.1
3/8	16.181	16.343	16.26	12.5
1/2	20.330	20.555	20.44	16.4
3/4	25.735	25.960	25.85	17.7
1	32.455	32.743	32.60	20.9
1 1/4	40.973	41.260	41.12	23.2
2	58.477	58.764	58.62	27.5

NPT ANSI B1.20.1 NPTF ANSI B1.20.3

HSS



N5120				N5120	N5120
N5120				NPT	NPTF

				1.75 x P	1.75 x P
				1:16	1:16





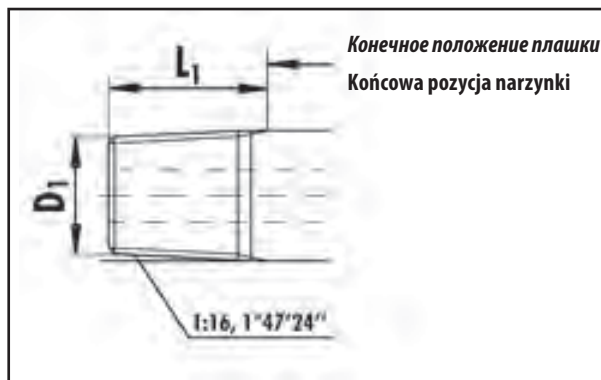

Ø" d ₁ NPT, NPTF	P TPI	d ₂ mm	l ₁ mm	⊕	ID	ID
1/16	27	25.0	9.0	4	104194	* 104204
1/8	27	30.0	11.0	5	104197	104207
1/4	18	38.0	14.0	5	104196	* 104206
3/8	18	45.0	14.0	5	104201	104211
1/2	14	45.0	18.0	6	104195	104205
3/4	14	55.0	22.0	6	104200	
1	11.5	65.0	25.0	7	104198	* 104208
1 1/4	11.5	75.0	26.0	8	104193	
1 1/2	11.5	90.0	27.0	8	* 104192	
2	11.5	105.0	28.0	9	* 104199	

Размеры диаметров под резьбы NPT и NPTF (в мм)

Wymiary wałków pod gwinty typu NPT oraz NPTF (w mm)



Ø" NPT	D ₁ mini mm	D ₁ maxi mm	D ₁ (guide line) mm	L ₁ (guide line) mm	Ø" NPTF	D ₁ mini mm	D ₁ maxi mm	D ₁ (guide line) mm	L ₁ (guide line) mm
1/16	7.521	7.643	7.58	8.4	1/16	7.525	7.617	7.57	8.4
1/8	9.866	9.988	9.93	8.5	1/8	9.870	9.962	9.92	8.5
1/4	13.099	13.255	13.18	12.7	1/4	13.129	13.215	13.17	12.7
3/8	16.518	16.674	16.60	12.9	3/8	16.548	16.634	16.59	12.9
1/2	20.551	20.713	20.63	16.8	1/2	20.617	20.703	20.66	16.8
3/4	25.866	26.028	25.95	17.1	3/4	25.932	26.018	25.98	17.1
1	32.419	32.591	32.51	21.3	1	32.475	32.561	32.52	21.3
1 1/4	41.144	41.316	41.23	21.9					
1 1/2	47.214	47.386	47.30	22.3					
2	59.226	59.398	59.31	23.1					

N5120			N5120	N5120		
N5120			PG	TR		

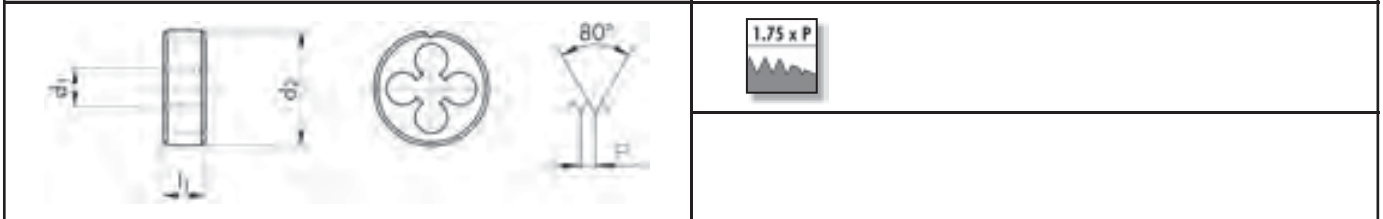

$\varnothing d_1$ PG	P TPI	d_2 mm	l_1 mm	\oplus	$\rightarrow \leftarrow$	ID
7	20	38.0	10.0	5	12.40	104220
9	18	38.0	10.0	5	15.10	104221
11	18	45.0	14.0	5	18.50	104212
13.5	18	45.0	14.0	6	20.30	104213
16	18	55.0	16.0	5	22.40	104214
21	16	65.0	18.0	6	28.15	104215
29	16	65.0	18.0	8	36.85	104216
36	16	90.0	22.0	8	46.85	104217
42	16	90.0	22.0	10	53.85	* 104218
48	16	105.0	22.0	9	59.15	104219

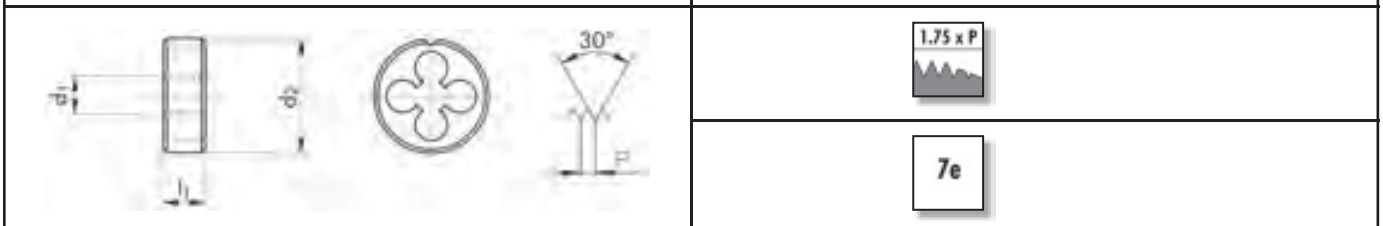

$\varnothing d_1$ TR	P mm	d_2 mm	l_1 mm	\oplus	$\rightarrow \leftarrow$	ID
*10	2	38.0	14.0	4	9.91	104231
12	3	38.0	14.0	4	11.88	104232
16	4	45.0	18.0	4	15.85	104234
18	4	45.0	18.0	5	17.85	* 104235
20	4	55.0	22.0	5	19.85	104236
24	5	65.0	25.0	5	23.83	* 104238
26	5	65.0	25.0	5	25.83	* 104239
28	5	65.0	25.0	5	27.83	* 104240
32	6	65.0	25.0	6	31.81	* 104242
36	6	65.0	25.0	6	35.81	* 104243



						N5110	N5120	N5120 LH	
						MC	MC	MC	
Ø" d ₁ W	P TPI	d ₂ mm	l ₁ mm	⊕	↔	ID	ID	ID	
1/16	60	16.0	5.0	3	1.51	* 103902			
3/32	48	16.0	5.0	4	2.30	103903			
1/8	40	20.0	5.0	4	3.09		104320		
5/32	32	20.0	7.0	4	3.88		104333		
3/16	24	20.0	7.0	4	4.66		104325		
1/4	20	20.0	7.0	4	6.24		104318		
5/16	18	25.0	9.0	4	7.82		104331	* 111391	
3/8	16	30.0	11.0	4	9.40		104329		
7/16	14	30.0	11.0	4	10.98		104336		
1/2	12	38.0	14.0	4	12.56		104316	* 104317	
5/8	11	45.0	18.0	4	15.72		104334	* 104335	
3/4	10	45.0	18.0	5	18.89		104327	* 104328	
7/8	9	55.0	22.0	5	22.10		104338		
1	8	55.0	22.0	5	25.27		104322		
1 1/8	7	65.0	25.0	5	28.44		* 104314		
1 3/8	6	65.0	25.0	6	34.77		* 104315		
2	4.5	90.0	36.0	7	50.62		* 104324		









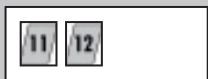

						N5220	N5220	Z5220	MS5220	
N5220				11	12					
N5220				11	12					
Z5220			NI	13	14	21				
MS5220				02	63					
						6g	6e	6g	6g	
$\varnothing d_1$ M	P mm	d_2 mm	l_1 mm				ID	ID ^{6g} - mm	ID	ID
1.2	0.25	16.0	2.0	3	1.17		* 104345			
1.4	0.30	16.0	2.6	4	1.36		104346			
1.6	0.35	16.0	2.6	4	1.54		104347			
1.7	0.35	16.0	2.6	4	1.64		104348			
1.8	0.35	16.0	2.6	4	1.74		* 104349			
2	0.40	16.0	3.5	4	1.93	1.90	104367	* 104366 0.030	* 104801	* 101362
2.3	0.40	16.0	3.5	4	2.23		104369		* 104802	
2.5	0.45	16.0	3.5	4	2.43	2.40	104371	104370 0.030	104803	* 101364
2.6	0.45	16.0	3.5	4	2.53		104372			
3	0.50	16.0	3.5	4	2.92	2.90	104375	104374 0.030	104804	* 101367
3.5	0.60	16.0	4.0	4	3.41		104376			
4	0.70	16.0	5.0	4	3.91	3.87	104380	104379 0.035	104805	* 101371
5	0.80	20.0	7.0	4	4.90	4.87	104384	104383 0.035	104806	* 101374
6	1.00	20.0	7.0	4	5.88	5.85	104388	104387 0.035	104807	* 101377
7	1.00	25.0	7.0	4	6.88		104392			
8	1.25	25.0	9.0	4	7.87	7.83	104397	104396 0.035	104808	
10	1.50	30.0	11.0	6	9.85	9.82	104354	104353 0.035		
12	1.75	30.0	11.0	6	11.83		104358			

≤ M1.4

6h

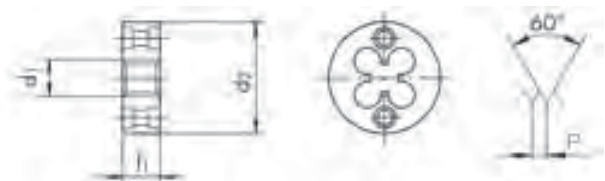
N5220    **N5220**

 **1.75 x P**

 **6g**







$\varnothing d_1$ MF	P mm	d_2 mm	l_1 mm	\oplus	$\rightarrow \leftarrow$	ID
3	0.35	16.0	3.0	4	2.94	104373
4	0.35	16.0	3.5	4	3.94	* 104377
4	0.50	16.0	4.0	4	3.93	104378
5	0.50	20.0	5.0	4	4.93	104382
6	0.50	20.0	5.0	4	5.93	104385
6	0.75	20.0	7.0	4	5.90	104386
7	0.50	25.0	7.0	4	6.93	* 104389
7	0.75	25.0	7.0	4	6.90	104390
8	0.50	25.0	7.0	6	7.93	* 104393
8	0.75	25.0	7.0	4	7.90	104394
8	1.00	25.0	7.0	4	7.88	104395
10	0.75	30.0	7.0	6	9.90	* 104350
10	1.00	30.0	7.0	6	9.88	104351
10	1.25	25.0	9.0	6	9.86	104352
12	1.00	30.0	7.0	6	11.88	104355
12	1.50	30.0	11.0	6	11.85	104356
14	1.00	35.0	10.0	6	13.88	104359
14	1.50	35.0	10.0	6	13.85	* 104360









N5310						N5310					
										11	12
										11	12
										1.75 x P	
										6g	
∅ d ₁ M	P mm	s mm	l ₁ mm	⊕	↔	ID					
3	0.50	18.0	5.0	3	2.92	104464					
3.5	0.60	18.0	5.0	3	3.41	* 104465					
4	0.70	18.0	5.0	3	3.91	104478					
4.5	0.75	18.0	7.0	3	4.41	* 104479					
5	0.80	18.0	7.0	4	4.90	104487					
6	1.00	18.0	7.0	4	5.88	104493					
7	1.00	21.0	9.0	4	6.88	* 104497					
8	1.25	21.0	9.0	4	7.87	104502					
9	1.25	21.0	9.0	5	8.87	* 104503					
10	1.50	27.0	11.0	4	9.85	104438					
11	1.50	27.0	11.0	5	10.85	* 104439					
12	1.75	36.0	14.0	4	11.83	104443					
14	2.00	36.0	14.0	4	13.82	104445					
16	2.00	41.0	18.0	4	15.82	104447					
18	2.50	41.0	18.0	5	17.79	104450					
20	2.50	41.0	18.0	5	19.79	104453					
22	2.50	50.0	22.0	5	21.79	104456					
24	3.00	50.0	22.0	5	23.76	104459					
27	3.00	60.0	25.0	5	26.76	104463					
30	3.50	60.0	25.0	5	29.73	104468					
33	3.50	60.0	25.0	6	32.73	* 104471					
36	4.00	60.0	25.0	6	35.70	104474					
42	4.50	70.0	30.0	7	41.69	* 104482					
48	5.00	85.0	36.0	7	47.66	104486					
52	5.00	85.0	36.0	8	51.66	* 104489					

N5310						N5310						
										11	12	
∅ d ₁ MF	P mm	s mm	l ₁ mm	⊕	↔	ID						
6	0.75	18.0	7.0	4	5.90	* 104492						
8	0.75	21.0	9.0	4	7.90	* 104500						
8	1.00	21.0	9.0	4	7.88	104501						
10	1.00	27.0	11.0	5	9.88	104436						
10	1.25	27.0	11.0	4	9.86	* 104437						
12	1.00	36.0	10.0	4	11.88	* 104440						
12	1.25	36.0	10.0	4	11.86	104441						
12	1.50	36.0	10.0	4	11.85	* 104442						
14	1.50	36.0	10.0	5	13.85	104444						
16	1.50	41.0	14.0	5	15.85	104446						
18	1.50	41.0	14.0	5	17.85	104448						
18	2.00	41.0	14.0	5	17.82	* 104449						
20	1.50	41.0	14.0	6	19.85	104451						
20	2.00	41.0	14.0	6	19.82	* 104452						
22	1.50	50.0	16.0	5	21.85	104454						
22	2.00	50.0	16.0	5	21.82	* 104455						
24	1.50	50.0	16.0	6	23.85	104457						
24	2.00	50.0	16.0	6	23.82	* 104458						
25	1.50	50.0	16.0	6	24.85	* 104460						
27	1.50	60.0	18.0	6	26.85	* 104461						
27	2.00	60.0	18.0	6	26.82	104462						
30	1.50	60.0	18.0	6	29.85	104466						
30	2.00	60.0	18.0	6	29.82	104467						
33	1.50	60.0	18.0	7	32.85	* 104469						
33	2.00	60.0	18.0	7	32.82	* 104470						
36	2.00	60.0	18.0	8	35.82	* 104473						
38	1.50	70.0	20.0	8	37.85	* 104475						
39	1.50	70.0	20.0	8	38.85	* 104476						
40	1.50	70.0	20.0	8	39.85	* 104480						
45	1.50	85.0	22.0	7	44.85	* 104483						
60	2.00	100.0	22.0	9	59.82	* 104494						
64	2.00	115.0	22.0	8	63.82	* 104495						
70	2.00	115.0	22.0	10	69.82	* 104498						

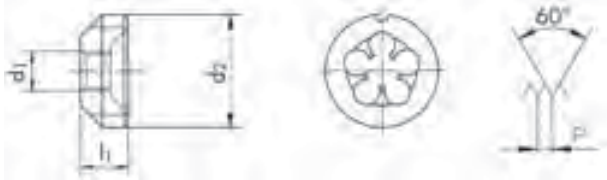









<p>N5310 11 12</p>							N5310			N5310
<p>N5310 11 12</p>										
										
							A			MC
\varnothing " d ₁ G	P TPI	s mm	l ₁ mm	\oplus		ID				
1/8	28	27.0	11.0	4	9.62	104429				
1/4	19	36.0	10.0	5	13.03	104428				
3/8	19	41.0	14.0	5	16.54	104433				
1/2	14	41.0	14.0	6	20.81	104427				
5/8	14	50.0	16.0	6	22.77	* 104434				
3/4	14	50.0	16.0	6	26.30	104432				
7/8	14	60.0	18.0	6	30.06	* 104435				
1	11	60.0	18.0	7	33.07	104430				
1 1/8	11	70.0	20.0	7	37.72	* 104424				
1 1/4	11	70.0	20.0	9	41.73	104423				
1 3/8	11	85.0	22.0	7	44.14	* 104426				
1 1/2	11	85.0	22.0	8	47.62	104422				
1 3/4	11	100.0	22.0	8	53.57	* 104425				
2	11	100.0	22.0	9	59.43	104431				
\varnothing " d ₁ W	P TPI	s mm	l ₁ mm	\oplus		ID				
1/8	40	18.0	5.0	3	3.09	* 104512				
3/16	24	18.0	7.0	3	4.66	* 104515				
1/4	20	18.0	7.0	4	6.24	* 104511				
3/8	16	27.0	11.0	4	9.40	* 104517				
7/16	14	27.0	11.0	5	10.98	* 104520				
1/2	12	36.0	14.0	4	12.56	104510				
9/16	12	36.0	14.0	4	14.14	* 104522				
5/8	11	41.0	18.0	4	15.72	* 104519				
3/4	10	41.0	18.0	5	18.89	* 104516				
7/8	9	50.0	22.0	5	22.10	* 104521				
1	8	50.0	22.0	6	25.27	104513				
1 1/8	7	60.0	25.0	5	28.44	* 104506				
1 3/8	6	60.0	25.0	6	34.77	* 104508				
1 1/2	6	70.0	30.0	6	37.95	* 104504				
1 3/4	5	85.0	36.0	6	44.28	* 104507				
2	4.5	85.0	36.0	7	50.63	* 104514				

N5420  						N5420	
							
							
$\varnothing d_1$ M	P mm	d_2 mm	l_1 mm			ID	
2.5	0.45	16.0	8.0	4	2.43	* 104527	
3	0.50	16.0	8.0	4	2.92	* 104529	
3.5	0.60	16.0	9.5	4	3.41	* 104530	
4	0.70	16.0	9.5	4	3.90	104531	
5	0.80	16.0	9.5	4	4.90	104532	
6	1.00	16.0	9.5	5	5.88	104533	
8	1.25	25.0	14.0	5	7.86	104535	
10	1.50	25.0	14.0	5	9.85	* 104523	











Указатель – резьбовые калибры пробки и кольца
Skorowidz – Sprawdziany tłoczkowe oraz pierścieniowe

















Характеристики Charakterystyki							
	D5701-1	D5701-2	D5703	D5703TC	D5720	D5722	D5725
M 6H / 6g DIN 13	250	250	250	250			
M 6G / 6e DIN 13			250				
M 6H / 6g LH DIN 13			250				
MF 6H / 6g DIN 13	252-253	253	252-253				
MF 6G / 6e DIN 13			252				
MF 6H / 6g LH DIN 13			252				
UNC ANSI B1.1	256		256				
UNF ANSI B1.1	257		257				
UNEF ANSI B1.1			257				
UN / UNS ANSI B1.1			256				
NPT ANSI B1.20.1					259		
NPTF ANSI B1.20.3					259		
G (BSP) DIN ISO 228	258	258	258				
Rp / R DIN 2999					259		
Rc / R ISO 7						259	
PG DIN 40430	258						258
EG M DIN 8140-3			260				
EG UNC NASM 33537			260				
EG UNF NASM 33537			260				

			
			
D5704	D5714	D5721	D5723
251	251		
251	251		
251			
254-255	254-255		
254			
256	256		
257	257		
257	257		
256	256		
		259	
		259	
258	258		
		259	
			259
258			









Пиктограммы – Piktogramy

-  „ПР”
„Go” - przechodni
-  „HE”
„No-go” - nieprzechodni
-  „ПР”/ „HE”
„Go” / „No-go” - przechodni/nieprzechodni
-  Класс точности 6H „ПР”
Tolerancja 6H „Go” - przechodni
-  Класс точности 6H „ПР”/ „HE”
Tolerancja 6G „Go” / „No-go” - przechodni/nieprzechodni
-  Класс точности 6H „HE”
Tolerancja 6g „No-go” - nieprzechodni
-  Калибр „ПР” с покрытием TiCN и сертификатом
„Go” - sprawdzian przechodni w powłoce TiCN oraz z certyfikatem
-  Левая резьба
Gwint lewy



M DIN 13







		D5701-1	D5701-2	D5703	D5703TC	D5703 LH	D5703
D5701-1 M1 - M1.4 =  D5703 M1 - M1.4 =  D5703TC 							
						 	
∅ D M	P mm	ID	ID	ID	ID	ID	ID
1	0.25	* 100021		100242			
1.1	0.25	* 100022		100243			
1.2	0.25	* 100023		100244			
1.4	0.30	* 100024		100245			
1.6	0.35	* 100025		100246		* 110168	
1.7	0.35	* 100026		100247			
1.8	0.35	* 100027		100248		* 110169	
2	0.40	* 100057		100278		105159	104982
2.2	0.45			100280			
2.3	0.40	* 100060		100281			
2.5	0.45	* 100062		100283		105160	104979
2.6	0.45	* 100064		100285			
3	0.50	* 100089		100310	104954	104964	104976
3.5	0.60			100312			104977
4	0.70	* 100112		100333	104955	104966	104978
4.5	0.75	* 100114		* 100335			* 110183
5	0.80	* 100127		100348	104956	104967	104980
6	1.00	* 100142		100363	104957	104968	104981
7	1.00	* 100148		100369		* 110186	* 110185
8	1.25	* 100152		100373	104958	104969	104983
9	1.25			100375			
10	1.50	* 100032		100253	104959	104970	104984
11	1.50			* 100256			
12	1.75	* 100040		100261		104971	104985
14	2.00	* 100045		100266		* 104972	104986
16	2.00	* 100050		100271		104973	104987
18	2.50	* 100055		100276			* 104988
20	2.50	* 100068		100289		104975	104989
22	2.50	* 100072		100293		* 110178	
24	3.00	* 100076		100297		110179	
27	3.00	* 100084		100305		110180	
30	3.50	* 100095		100316		* 110181	
33	3.50	* 100101		100322			
36	4.00	* 100107		100328			
39	4.00	* 100109		100330			
42	4.50	100119	142843				
45	4.50	100122	142844				
48	5.00	100125	142845				
52	5.00	100132	142846				
56	5.50	100137	142847				

M DIN 13



		D5704	D5704 LH	D5704	D5714	D5714		
D5704 M1 - M1.4 =  D5714 M1 - M1.4 = 								
				LH				
Ø D M	P mm	ID	ID	ID	ID	ID		
1	0.25	100480			110419			
1.2	0.25	100481			110420			
1.4	0.30	100482			110421			
1.6	0.35	100483			110422			
1.7	0.35	100484			111439			
1.8	0.35	100485			110423			
2	0.40	100515	105006	104997	100734	142833		
2.2	0.45	100517			100735			
2.3	0.40	100518			100736			
2.5	0.45	100520		104991	100737	142834		
2.6	0.45	100522			100738			
3	0.50	100547	105001	104990	100763	142835		
3.5	0.60	100549	110302	110301	100765	142836		
4	0.70	100570	105003	104992	100774	142837		
4.5	0.75	* 100572						
5	0.80	100585	105004	104993	100778	143406		
6	1.00	100600	105005	104994	100781	135556		
7	1.00	100605	126560	104995	100783	142840		
8	1.25	100611	105007	104996	100786	142841		
9	1.25	100610			100788			
10	1.50	100490	105008	104998	100711	142842		
11	1.50	* 100493			* 100713			
12	1.75	100498	105009	104999	100718			
14	2.00	100503	105010		100723			
16	2.00	100508	105011	* 105000	100728			
18	2.50	100513	105012		100733			
20	2.50	100526	105013		100742			
22	2.50	100530	110298		100746			
24	3.00	100534	110299		100750			
27	3.00	100542	110300		100758			
30	3.50	100553	110303		100769			
33	3.50	100559	110304		100770			
36	4.00	100565	110305		100771			
39	4.00	100567			110440			
42	4.50	100577			110445			
45	4.50	100580			110448			
48	5.00	100583			110451			
52	5.00	100590			110456			
56	5.50	100595			110461			



		D5701-1	D5703	D5703 LH	D5703		
							
							
∅ D MF	P mm	ID	ID	ID	ID		
2.5	0.35		100282				
3	0.35	* 100088	100309				
3.5	0.35		* 100311				
4	0.35	* 100110	100331				
4	0.50	* 100111	100332			* 105044	
4.5	0.50		100334				
5	0.50	* 100126	100347	105016		105045	
6	0.50	* 100140	100361	110184			
6	0.75	* 100141	100362	* 105017		105046	
7	0.50		100367				
7	0.75	* 100147	100368				
8	0.50	* 100149	100370	* 110187			
8	0.75	* 100150	100371	105018		105047	
8	1.00	* 100151	100372	105019		105048	
9	1.00	* 100153	100374				
10	0.50	* 100028	100249				
10	0.75	* 100029	100250	* 110170			
10	1.00	* 100030	100251	105020		105049	
10	1.25	* 100031	100252				
11	0.75	* 100033	100254				
11	1.00	* 100034	100255				
12	0.75	* 100036	100257				
12	1.00	* 100037	100258	105021		105050	
12	1.25	* 100038	100259				
12	1.50	* 100039	100260	105022			
13	1.00	* 100041	* 100262				
14	1.00		100263	110171			
14	1.25		100264				
14	1.50	* 100044	100265	105023		105052	
15	1.00	* 100046	100267				
15	1.50		100268				
16	1.00	* 100048	100269	110172			
16	1.50	* 100049	100270	105024		105053	
17	1.00		100272				
18	1.00	* 100052	100273				
18	1.50	* 100053	100274	105025		105054	
18	2.00	* 100054	100275				
20	1.00	* 100065	100286				
20	1.50	* 100066	100287	105026			
20	2.00	* 100067	100288			110176	
22	1.00	* 100069	100290				
22	1.50	* 100070	100291	110177			
22	2.00		100292				
24	1.00	* 100073	100294				
24	1.50	* 100074	100295				

		D5701-1	D5701-2	D5703			
							
							
Ø D MF	P mm	ID	ID	ID			
24	2.00			100296			
25	1.00	* 100077		100298			
25	1.50	* 100078		100299			
25	2.00			100300			
26	1.00	* 100080		100301			
26	1.50	* 100081		100302			
27	1.50	* 100082		100303			
27	2.00	* 100083		100304			
28	1.00	* 100085		100306			
28	1.50	* 100086		100307			
28	2.00	* 100087		100308			
30	1.00	* 100092		100313			
30	1.50	* 100093		100314			
30	2.00	* 100094		100315			
32	1.00			100317			
32	1.50	* 100097		100318			
32	2.00			100319			
33	1.50			100320			
33	2.00	* 100100		100321			
35	1.50	* 100102		100323			
36	1.50	* 100104		100325			
36	2.00	* 100105		100326			
36	3.00			100327			
38	1.50	* 100108		100329			
40	1.50			100336			
40	2.00			100337			
42	1.50	100117	142848				
42	2.00	100118	142849				
45	1.50	100120	110127				
45	2.00	100121	142851				
48	1.50	100123	123180				
48	2.00	100124	142853				
50	1.50	100128	142854				
50	2.00	100129	142855				
52	1.50	100130	123428				
52	2.00	100131	142857				
55	1.50	100133	123468				
55	2.00	100134	142859				
56	1.50	100135	142860				
56	2.00	100136	142861				
58	1.50	100138	142862				
58	2.00	100139	142863				
60	1.50	100143	142864				
60	2.00	100144	142865				





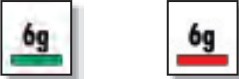

		D5704	D5704 LH	D5714			
							
							
∅ D MF	P mm	ID	ID	ID			
2.5	0.35	100519		110427			
3	0.35	100546		100762			
3.5	0.35	100548		100764			
4	0.35	100568		100772			
4	0.50	100569		100773			
4.5	0.50	100571		100775			
5	0.50	100584	105057	100777			
6	0.50	100598	110307	100779			
6	0.75	100599	105058	100780			
7	0.50	100603		110467			
7	0.75	100604		100782			
8	0.50	100606	* 110309	110468			
8	0.75	100607	105059	100784			
8	1.00	100608	105060	100785			
9	1.00	100609		100787			
10	0.50	100486		100707			
10	0.75	100487		100708			
10	1.00	100488	105061	100709			
10	1.25	100489		100710			
11	0.75	100491		110424			
11	1.00	100492		100712			
12	0.75	100494		100714			
12	1.00	100495	105062	100715			
12	1.25	100496		100716			
12	1.50	100497	105063	100717			
13	1.00	100499		100719			
14	1.00	100500	110290	100720			
14	1.25	100501		100721			
14	1.50	100502	105064	100722			
15	1.00	100504		100724			
15	1.50	100505		100725			
16	1.00	100506	110292	100726			
16	1.50	100507	105065	100727			
17	1.00	100509		100729			
18	1.00	100510		100730			
18	1.50	100511	105066	100731			
18	2.00	* 100512		* 100732			
20	1.00	100523	110295	100739			
20	1.50	100524	105067	100740			
20	2.00	100525		100741			
22	1.00	100527		100743			
22	1.50	100528	* 110297	100744			
22	2.00	100529		100745			
24	1.00	100531		100747			
24	1.50	100532		100748			









		D5704	D5714				
							
							
Ø D MF	P mm	ID	ID				
24	2.00	100533	100749				
25	1.00	100535	100751				
25	1.50	100536	100752				
26	1.00	100538	100754				
26	1.50	100539	100755				
27	1.50	100540	100756				
27	2.00	100541	100757				
28	1.00	100543	100759				
28	1.50	100544	100760				
30	1.00	100550	100766				
30	1.50	100551	100767				
30	2.00	100552	100768				
32	1.00	100554	110429				
32	1.50	100555	110430				
32	2.00	100556	110431				
33	1.50	100557	110432				
33	2.00	100558	110433				
35	1.50	100560	110434				
36	1.50	100562	110436				
36	2.00	100563	110437				
36	3.00	100564	110438				
38	1.50	100566	110439				
40	1.50	100573	110441				
42	1.50	100575	110443				
42	2.00	100576	110444				
45	1.50	100578	110446				
45	2.00	100579	110447				
48	1.50	100581	110449				
48	2.00	100582	110450				
50	1.50	100586	110452				
50	2.00	100587	110453				
52	1.50		* 110454				
52	2.00	100589	110455				
55	1.50	100591	110457				
55	2.00	100592	110458				
56	1.50	100593	110459				
56	2.00	100594	110460				
58	1.50	100596	110462				
58	2.00	100597	110463				
60	1.50	100601	110464				
60	2.00	105014	110465				















UNC, UN, UNS ANSI B1.1













		D5701-1	D5703	D5704	D5714		
							
							
Ø" D UNC	P TPI	ID	ID	ID	ID		
1	64		100408	110347	110473		
2	56	* 110076	100414	110353	110479		
3	48	* 110077	100416	110354	110480		
4	40	* 110080	110224	110357	110483		
5	40		100420	110358	110484		
6	32	* 110084	100423	110361	110487		
8	32	* 110087	100426	110364	110490		
10	24	* 110074	100412	110351	110477		
12	24		100413	* 110352	* 110478		
1/4	20	* 110072	100410	110349	110475		
5/16	18	* 110082	100421	110359	110485		
3/8	16	* 110079	100418	110356	110482		
7/16	14	* 110085	100424	110362	110488		
1/2	13	* 110071	100409	110348	110474		
9/16	12		100427	110365	110491		
5/8	11	* 110083	100422	110360	110486		
3/4	10	* 110078	100417	110355	110481		
7/8	9		100425	110363	110489		
1	8	* 110073	100411	110350	110476		
1 1/8	7	* 110068	100405	110345	110471		
1 1/4	7	* 110067	100404	110344	110470		
1 3/8	6	* 110069	100407	110346	110472		
1 1/2	6	* 110066	100403	110343	110469		
Ø" D UNS	P TPI	ID	ID	ID			
1/4	36	* 129290	* 129281	* 129282			
Ø" D UN	P TPI	ID					
1 1/8	8	* 129635					
1 1/4	8	* 116423					
1 3/8	8	* 116424					
1 1/2	8	* 129602					

UNF, UNEF ANSI B1.1

		D5701-1	D5703	D5704	D5714		
							
							
Ø" D UNF	P TPI	ID	ID	ID	ID		
0	80	* 128528	110246	* 110378	* 110503		
1	72	* 110105	110251	110383	110508		
2	64		110256	110389	110514		
3	56	* 110112	110257	110390	110515		
4	48		110260	110393	110518		
5	44	* 110116	110261				
6	40		110264	110397	110522		
8	36	* 110122	110267	* 110400			
10	32	* 110109	110254	110387	110512		
12	28		110255	110388	110513		
1/4	28	* 110107	110006	110385	110510		
5/16	24	* 110117	110262	110395	110520		
3/8	24	* 110114	110259	110392	110517		
7/16	20	* 110120	110265	110398	111440		
1/2	20	* 110106	110252	110384	110509		
9/16	18		110268	110401	110525		
5/8	18	* 110118	110263	110396	110521		
3/4	16	* 110113	110258	110391	110516		
7/8	14	* 110121	110266	110399	110523		
1	12	* 110108	* 128646	110386	110511		
1 1/8	12	* 110103	110249	110381	110506		
1 1/4	12	* 110102	110248	110380	110505		
1 3/8	12	* 110104	110250	110382	110507		
1 1/2	12	* 110101	110247	110379	110504		
Ø" D UNEF	P TPI	ID	ID	ID			
12	32	110238	110370	110495			
1/4	32	110236	110368	110493			
5/16	32	110241	110373	110498			
3/8	32	110240	110372	110497			
7/16	28	110243	110375	110500			
1/2	28	110235	110367	110492			
9/16	24	110245	110377	110502			
5/8	24	110242	110374	110499			
3/4	20	110239	110371	110496			
7/8	20	110244		* 110501			
1	20	110253	110369	110494			



		D5701-1	D5701-2	D5703	D5704	D5714	D5725
							
							
Ø" D G	P TPI	ID	ID	ID	ID	ID	
1/8	28	* 110044		110009	110277	110408	
1/4	19			110003	110276	110407	
3/8	19	* 110052		110162	110284	110415	
1/2	14	* 110000		110001	110275	110406	
5/8	14			110164	110286	110417	
3/4	14			110161	110283	110414	
7/8	14	* 110054		110165	* 110287	* 110418	
1	11	* 110045		110156	110278	110409	
1 1/8	11			110154	* 110273	* 110404	
1 1/4	11	110041	119459		110272	110403	
1 1/2	11	110040	119429		110271	110402	
1 3/4	11	110043	142868		110274	110405	
2	11	110050	110126		110282	110413	
2 1/4	11	* 110047	* 142870			* 110411	
2 1/2	11	* 110046	* 110125		* 110279	* 110410	
2 3/4	11	* 110049	* 142872			* 110412	
3	11		* 111438		* 110285	* 110416	
Ø D PG	P TPI	ID		ID		ID	
7	20			110335		110216	
9	18			110336		110217	
11	18			110328		110205	
13.5	18	* 110057		110329		110209	
16	18			110330		110210	
21	16			110331		110211	
29	16			110332		110212	

NPT, NPTF ANSI B1.20.1 ANSI B1.20.3 R, Rc, Rp ISO 7-2:1982 DIN 2999

		D5720	D5721	D5720	D5721	D5722	D5723
		DIN 2999		DIN 2999		ISO 7-2:1982	
							
							
Ø" D NPT	P TPI	ID	ID				
1/16	27	110190	110313				
1/8	27	110193	110316				
1/4	18	110192	110315				
3/8	18	110197	110320				
1/2	14	110191	110314				
3/4	14	110196	110319				
1	11.5	110194	110317				
1 1/4	11.5	110189	110312				
1 1/2	11.5	110188	110311				
2	11.5	110195	110318				
Ø" D NPTF	P TPI	ID	ID				
1/8	27	110201	110324				
1/4	18	110200	110323				
3/8	18	110204	110327				
1/2	14	110199	110322				
3/4	14	110203	110326				
1	11.5	110202	110325				
Ø" D R, Rc, Rp	P TPI	ID		Rp	R	Rc / Rp	R
1/8	28					* 142917	* 142923
1/4	19			* 110219			
1/2	14			* 110218	* 110337	* 142920	* 142926
3/4	14			* 110222	* 110341	* 142921	
1	11			* 110221	* 110340	* 142922	



EG M DIN 8140-3 EG UNC, EG UNF NASM 33537

		D5703	D5703	D5703						
										
										
∅ D EG M	P mm	ID								
2.5	0.45	110132								
3	0.50	110133								
4	0.70	110134								
5	0.80	110135								
6	1.00	110136								
8	1.25	110137								
10	1.50	110128								
12	1.75	110129								
14	2.00	* 110130								
16	2.00	110131								
∅" D EG UNC	P TPI	ID								
4	40	110141								
6	32	110143								
8	32	110144								
10	24	110139								
1/4	20	110138								
5/16	18	110142								
3/8	16	110140								
∅" D EG UNF	P TPI	ID								
6	40	110150								
8	36	110151								
10	32	110147								
1/4	28	110145								
5/16	24	110149								
3/8	24	110148								

eCatalogue

<http://www.dcswiss.com/EN/Products>

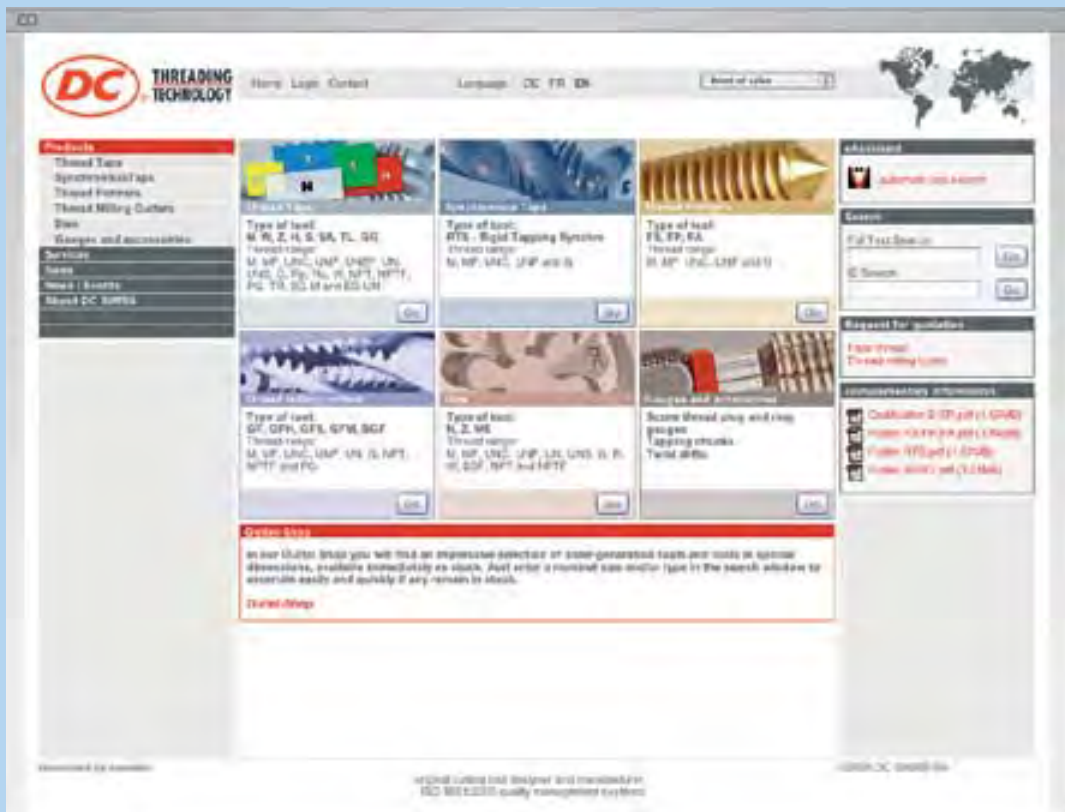

Programming data request

<http://www.dcswiss.com/EN/Products/ThreadMillingCutters>



The screenshot displays the DC Threading Technology website interface. At the top left is the DC logo and 'THREADING TECHNOLOGY' text. Navigation links for 'Home', 'Login', and 'Contact' are visible. A language dropdown is set to 'EN', and a 'Print of page' button is present. A world map icon is in the top right corner. A sidebar on the left contains a menu with 'Products', 'Services', 'Sales', 'News / Events', and 'About DC Cutters'. The main content area features a form titled 'Enter application details - Thread milling cutter'. The form includes a 'Material (from)' dropdown set to 'Alu6061', a 'Program name' dropdown set to 'ISO', and a 'Cut direction' dropdown set to 'L'. Other fields include 'Thread ID' (6), 'Flute ID' (2), 'Cork hole ID (mm)' (1), 'Diameter thread (mm)', 'Pitch', 'Number of teeth' (3), 'Cut direction' (L), 'Milling direction' (Clockwise), and 'Feed (mm/min)'. A 'Calculate' button is at the bottom right of the form. Below the form, a disclaimer states: 'DC BMSB ES will not be held responsible for consequential damage to machine and/or personnel, in every case the approved data and programs shall be verified with a test run on the machine!'. At the bottom of the page, there is a 'Designed by Aesent' logo, a '© rights reserved' notice with contact information, and a '©2008 DC SWISS SA' copyright notice.



- ▶ **Резьбонарезные патроны SRT** **2**
- ▶ **Оprawki do gwintowania SRT**
SRT054, SRT312, SRT520



264/265

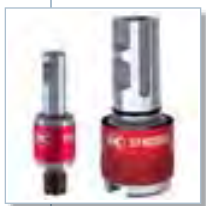

SRT

- ▶ **Твердосплавные сверла** **2**
- ▶ **Wiertła pełnowęglkowe**
M, MF, UNC, UNF



266/267



- ▶ **Плашкодержатели** **2**
- ▶ **Воротки для метчиков**
- ▶ **Удлинители**
- ▶ **Таблицы :**
 - Скорости резания
 - Переводная таблица
 - Диаметр отверстия
 - Диаметр прутка под плашку
- ▶ **Технические анкеты**
- ▶ **Ценовые дополнения**
- ▶ **Условия поставки и оплаты**



272







- ▶ **Оprawki do narzynek** **2**
- ▶ **Klucze do gwintowników**
- ▶ **Przedłużki**
- ▶ **Tabele :**
 - prędkości skrawania
 - przeliczniki
 - średnice otworów
 - średnice wałków
- ▶ **Kwestionariusze techniczne**
- ▶ **Dodatkowe opłaty**
- ▶ **Dostawa i warunki płatności**



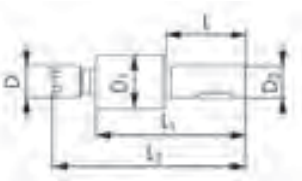
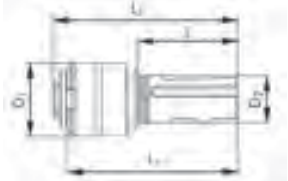

272

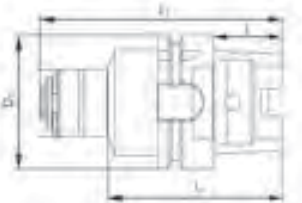

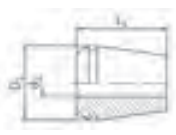
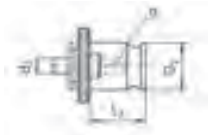

<h1>SRT</h1>								SRT054	SRT312 D20-2	SRT312 D25-2	SRT520 D25-2
<div style="display: flex; justify-content: space-around;"> <div style="text-align: center;"> <p>SRT054</p>  </div> <div style="text-align: center;"> <p>SRT312 / SRT520</p>  </div> </div>											
D	D ₁	D ₂	L	L ₁	L ₂	DIN 1835		ID	ID	ID	ID
mm	mm	mm	mm	mm	mm						
M0.5 - M4	12	20	12	33	59	75.0	B	127413			
M3 - M12		39	20	47	86	92.0	B	✓	162832		
M3 - M12		39	25	53	90	97.5	B	✓		162831	
M5 - M20		56	25	53	110	122.0	B	✓			162833
<h1>SRT</h1>										SRT312 HSK-A63	SRT520 HSK-A63
<p>SRT312 / SRT520</p> 											
D ₁	L	L ₁	L ₂					ID	ID		
mm	mm	mm	mm								
M3 - M12	63	32	74	118.5			✓	163383			
M5 - M20	63	32	74	143.0			✓				163384

SRT						D9865-	D9820-	D9825-		
<div style="display: flex; justify-content: space-around;"> <div style="text-align: center;"> <p>D9865-</p>  </div> <div style="text-align: center;"> <p>D9820- / D9825-</p>  </div> </div>										
No	D ₂ mm	L ₃ mm	d ₂ mm	α mm	SRT054	SRT312	SRT520	ID	ID	ID
D9865-0200	8.5	13.5	2.0		✓			118895		
D9865-0250	8.5	13.5	2.5		✓			118896		
D9865-0300	8.5	13.5	3.0		✓			118897		
D9865-0350	8.5	13.5	3.5		✓			118898		
D9865-0400	8.5	13.5	4.0		✓			118899		
D9865-0450	8.5	13.5	4.5		✓			118900		
D9820-0035	19.0	21.5	3.5	2.7		✓			129916	
D9820-0045	19.0	21.5	4.5	3.4		✓			129918	
D9820-0060	19.0	21.5	6.0	4.9		✓			129920	
D9820-0070	19.0	21.5	7.0	5.5		✓			129921	
D9820-0080	19.0	21.5	8.0	6.2		✓			129922	
D9820-0090	19.0	21.5	9.0	7.0		✓			129923	
D9820-0100	19.0	21.5	10.0	8.0		✓			129924	
D9820-0110	19.0	21.5	11.0	9.0		✓			129925	
D9825-0060	31.0	35.0	6.0	4.9			✓			129927
D9825-0070	31.0	35.0	7.0	5.5			✓			129928
D9825-0080	31.0	35.0	8.0	6.2			✓			129929
D9825-0090	31.0	35.0	9.0	7.0			✓			129930
D9825-0100	31.0	35.0	10.0	8.0			✓			129931
D9825-0110	31.0	35.0	11.0	9.0			✓			148303
D9825-0120	31.0	35.0	12.0	9.0			✓			129932
D9825-0160	31.0	35.0	16.0	12.0			✓			129934
D9825-0180	31.0	35.0	18.0	14.5			✓			151355

Твердосплавные спиральные сверла
Wiertła pełnowęglkowe

VHM
CAR



HBK
HEK

sur demande
auf Anfrage
on request
su richiesta
sobre pedido

						F313VS			
<p>F313VS</p>									
$\varnothing d_1$ (h_7)	d_2 (h_6) mm	l_1 mm	l_2 mm			ID			
0.88	3.0	38.0	8.0	2	M 1	158515			
1.08	3.0	38.0	10.0	2	M 1.2	158516			
1.25	3.0	38.0	12.0	2	M 1.4	158517			
1.45	3.0	38.0	12.0	2	M 1.6	158518			
1.65	3.0	38.0	12.0	2	M 1.8	158519			
1.80	3.0	38.0	12.0	2	M 2	158520			
1.95	3.0	38.0	12.0	2	UNC 2-56	158521			
2.30	3.0	38.0	16.0	2	M 2.5	158522			
2.55	3.0	38.0	16.0	2	UNC 4-40	158523			
2.80	3.0	38.0	16.0	2	M 3	158524			

Твердосплавные спиральные сверла
Wiertła pełnowęglkowe



sur demande
auf Anfrage
on request
su richiesta
sobre pedido

		F285VS	F286VS				
F285VS							
F286VS							
$\varnothing d_1$ (m ₇)	d_2 (h ₈) mm	l_1 mm	l_2 mm	l_3 mm			ID
3.15	6.0	62.0	20.0	14.0	2	UNC 6-32	158525
3.20	6.0	62.0	20.0	14.0	2	UNF 6-40	158526
3.25	6.0	62.0	20.0	14.0	2	M 3.5	158527
3.70	6.0	62.0	20.0	14.0	2	M 4	158528
3.80	6.0	66.0	24.0	17.0	2	M 4 x 0.50 / UNC 8-32	158529
4.35	6.0	66.0	24.0	17.0	2	UNC 10-24	158530
4.45	6.0	66.0	24.0	17.0	2	UNF 10-32	158531
4.65	6.0	66.0	24.0	17.0	2	M 5	158532
4.80	6.0	66.0	28.0	20.0	2	M 5 x 0.50	158533
5.55	6.0	66.0	28.0	20.0	2	M 6	158534
5.65	6.0	66.0	28.0	20.0	2	M 6 x 0.75	158535
5.75	6.0	66.0	28.0	20.0	2	UNC 1/4-20	158536
5.80	6.0	66.0	28.0	20.0	2	M 6 x 0.50	158537
5.95	6.0	66.0	28.0	20.0	2	UNF 1/4-28	158538
7.30	8.0	79.0	41.0	29.0	2	UNC 5/16-18	158539
7.40	8.0	79.0	41.0	29.0	2	M 8	158540
7.45	8.0	79.0	41.0	29.0	2	UNF 5/16-24	158541
7.55	8.0	79.0	41.0	29.0	2	M 8 x 1.00	158542
7.65	8.0	79.0	41.0	29.0	2	M 8 x 0.75	158543
9.30	10.0	89.0	47.0	35.0	2	M 10	158544
9.55	10.0	89.0	47.0	35.0	2	M 10 x 1.00	158545
11.20	12.0	102.0	55.0	40.0	2	M 12	158546
$\varnothing d_1$ (m ₇)	d_2 (h ₈) mm	l_1 mm	l_2 mm	l_3 mm			ID
3.30	6.0	66.0	28.0	23.0	2	M 4	160989
4.20	6.0	74.0	36.0	29.0	2	M 5	160990
5.00	6.0	82.0	44.0	35.0	2	M 6	160991
6.80	8.0	91.0	53.0	43.0	2	M 8	160992
8.50	10.0	103.0	61.0	49.0	2	M 10	160993
10.20	12.0	118.0	71.0	56.0	2	M 12	160994

**СКОРОСТИ РЕЗАНИЯ И ЗНАЧЕНИЯ ПОДАЧИ
PRĘDKOŚCI SKRAWANIA I POSUWY**

DC таблица для твердосплавных сверл
Tabela **DC** dla wiertel pełnowęglkowych

Группы материалов Grupy materiałowe		Описание материалов Примеры для групп применения, стр. 5.	Означеніе материала Примеры для групп zastosowań, strona 6.	Твердость Twardość (HB)	Предел прочности Wytrzymałość на растяжение Rm (N/mm ²)	Удлинение Wydłużenie A (%)
10 Стали Stale	11	Автоматные стали	Stale szybko tnące	< 200	< 700	< 10
	12	Структурные/цементуемые стали	Stale konstrukcyjne/nawęglane	< 200	< 700	< 30
	13	Углеродистые стали	Stale węglowe	< 300	< 1000	< 20
	14	Легированные < 850 N/mm ²	Stale stopowe < 850 N/mm ²	< 250	< 850	< 30
	15	Легированные стали > 850 - < 1150 N/mm ²	Stale stopowe > 850 - < 1150 N/mm ²	> 250	> 850	< 30
	16	Высокопрочные легированные стали	Stale stopowe o dużej wytrzymałości	> 250	> 850	< 12
20 Нержавеющие стали Stale nierdzewne	21	Легкообрабатываемые нержавеющие стали	Stale automatowe nierdzewne	< 250	< 850	< 25
	22	Аустенитные нержавеющие стали	Austeniczne stale nierdzewne	< 250	< 850	> 20
	23	Ферритные и мартенситные < 850 N/mm ²	Stale ferrytyczne i martenzytyczne < 850 N/mm ²	< 250	< 850	> 20
	24	Ферритные и мартенситные > 850 - < 1150 N/mm ²	Stale ferrytyczne i martenzytyczne > 850 - < 1150 N/mm ²	> 250	> 850	> 15
30 Чугун Żeliwo szare	31	Чугун	Żeliwo szare	< 250	< 850	< 10
	32	Ковкий и высокопрочный чугун	Żeliwo sferoidalne	< 250	< 850	> 10
40 Титан Tytan	41	Чистый титан	Чистый титан	< 250	< 850	> 20
	42	Титановые сплавы	Stopy tytanu	> 250	> 850	< 20
50 Никель Nikiel	51	Никелевые сплавы 1 < 850 N/mm ²	Stopy niklu 1 < 850 N/mm ²	< 250	< 850	> 25
	52	Никелевые сплавы 2 > 850 - < 1150 N/mm ²	Stopy niklu 2 > 850 - < 1150 N/mm ²	> 250	> 850	< 25
	53	Никелевые сплавы 3 > 1150 - ≤ 1600 N/mm ²	Stopy niklu 3 > 1150 - ≤ 1600 N/mm ²	> 340	> 1150	< 20
60 Медь Miedź	61	Чистая медь (электротехническая)	Чистая медь (медь электролитическая)	< 120	< 400	> 12
	62	Короткостружечная латунь	Мosiądz z krótkim wiórem, brąz fosforowy, brąz armatni	< 200	< 700	< 12
	63	Длинностружечная латунь	Мosiądz z długim wiórem	< 200	< 700	> 12
70 Алюминий, Магний Aluminium, Magnez	71	Нелегированный алюминий	Алюминий нестоповый	< 100	< 350	> 15
	72	Алюминий Si < 1.5 %	Stopy aluminium Si < 1.5 %	< 150	< 500	> 15
	73	Алюминий Si > 1.5 % - < 10 %	Stopy aluminium Si > 1.5 % - < 10 %	< 120	< 400	< 15
	74	Алюминий Si > 10 %, сплавы магния	Stopy aluminium Si > 10 %, Stopy magnezu	< 120	< 400	< 10
80 Сложные пластики, композиты Творzywa sztuczne	81	Термопластики	Творzywa sztuczne - termoplasty	-	-	-
	82	Дуропластики	Творzywa sztuczne - duroпласты	-	-	-
	83	Стеклопластики	Творzywa sztuczne wzmacniane włóknem szklanym	-	-	-

Подача f (мм/об.)

Posuw f (mm/obr.)

Vc (m/min) С покрытием VS Powlekany „VS“		Ø 1 mm	Ø 2 mm	Ø 4 mm	Ø 8 mm	Ø 10 mm	Ø 12 mm
70 ÷ 90	11	0.015	0.020	0.040	0.120	0.160	0.200
70 ÷ 90	12	0.015	0.020	0.040	0.120	0.160	0.200
70 ÷ 90	13	0.015	0.020	0.040	0.120	0.160	0.200
70 ÷ 90	14	0.015	0.020	0.040	0.120	0.160	0.200
60 ÷ 80	15	0.015	0.020	0.060	0.080	0.120	0.160
	16						
40 ÷ 60	21	0.010	0.020	0.040	0.080	0.100	0.160
40 ÷ 60	22	0.010	0.020	0.040	0.080	0.100	0.160
40 ÷ 60	23	0.010	0.020	0.040	0.080	0.100	0.160
40 ÷ 60	24	0.010	0.020	0.040	0.080	0.100	0.120
70 ÷ 130	31	0.030	0.040	0.060	0.120	0.240	0.300
70 ÷ 130	32	0.030	0.040	0.060	0.120	0.240	0.300
40 ÷ 80	41	0.005	0.010	0.010	0.030	0.060	0.080
	42						
30 ÷ 50	51	0.010	0.020	0.040	0.080	0.100	0.120
	52						
	53						
70 ÷ 150	61	0.020	0.040	0.060	0.120	0.160	0.200
	62						
70 ÷ 150	63	0.020	0.040	0.060	0.120	0.160	0.200
100 ÷ 160	71	0.030	0.050	0.080	0.160	0.240	0.320
100 ÷ 160	72	0.030	0.050	0.080	0.160	0.240	0.320
60 ÷ 130	73	0.025	0.040	0.060	0.120	0.180	0.240
60 ÷ 130	74	0.025	0.040	0.060	0.120	0.180	0.240
	81						
	82						
	83						



Значения носят рекомендательный характер. Zalecane wartości.



Плашкодержатели и воротки для метчиков
Oprawki do narzynek i klucze do gwintowników

<p>D5810- Плашкодержатели для круглых плашек по DIN EN 22568, DIN EN 24230, DIN EN 24231, DIN EN 40434. Oprawki do narzynek okrągłych wg DIN EN 22568, DIN EN 24230, DIN EN 24231, DIN EN 40434.</p> <p>D5820- Воротки для метчиков, регулируемые DIN 1814 Klucze do gwintowników, regulowane DIN 1814</p>									D5810-	D5820-
										
DIN EN No D5810-	M Ø	MF Ø	UNC Ø	UNF Ø	UNEF UNS UN Ø	W Ø	G Ø	NPT NPTF R (BSPT) Ø	ID	
1	16 x 5	1 - 2.6	2 - 2.6	No 1 - 4	No 1 - 4		1/16" - 3/32"		110536	
2	20 x 5	3 - 4	3 - 6	No 5	No 5 - 6		1/8"		110546	
3	20 x 7	4.5 - 6		No 6 - 1/4"	No 8 - 1/4"	No 12 - 1/4"	5/32" - 1/4"		110548	
4	25 x 9	7 - 9	7 - 9	5/16"	5/16"	5/16"	5/16"	1/16"	110549	
5	30 x 11	10 - 11	10 - 11	3/8" - 7/16"	3/8" - 7/16"	3/8" - 7/16"	3/8" - 7/16"	1/8"	110550	
6	38 x 10		12 - 15		1/2" - 9/16"	1/2" - 9/16"		1/4"	110551	
7	38 x 14	12 - 14		1/2" - 9/16"			1/2" - 9/16"	1/4"	110552	
8	45 x 14		16 - 20		5/8" - 3/4"	5/8" - 13/16"		3/8" - 1/2"	110553	
9	45 x 18	16 - 20		5/8" - 3/4"			5/8" - 3/4"	1/2"	110554	
10	55 x 16		22 - 26		7/8" - 1"	7/8" - 1"		5/8" - 3/4"	110537	
11	55 x 22	22 - 24		7/8" - 1"			7/8" - 1"	3/4"	110538	
12	65 x 18		*27 - 36		1 1/8" - 1 3/8"	1 1/16" - 1 3/8"		7/8" - 1"	110539	
13	65 x 25	27 - 36		1 1/8" - 1 3/8"			1 1/8" - 1 3/8"	1"	110540	
14	75 x 20		38 - 42		1 1/2"	1 7/16" - 1 1/2"		1 1/8" - 1 1/4"	110541	
15	75 x 30	39 - 42		1 1/2"			1 1/2" - 1 5/8"		110542	
16	90 x 22		45 - 52			1 3/4" - 2"		1 3/8" - 1 3/4"	110543	
17	90 x 36	45 - 52		1 3/4" - 2"			1 3/4" - 2"		110544	
18	105 x 22		55 - 65					2" - 2 1/4"	110545	
<p>* Для шага 3 мм используйте №13 Do skoków 3 mm użyj Nr. 13</p>										
No D5820-	a mm								ID	
0	2.0 - 5.0								110555	
1	2.0 - 6.0								110556	
2	4.0 - 9.0								110557	
3	4.9 - 12.0								110558	
4	5.5 - 16.0								110559	
5	7.0 - 20.0								110560	

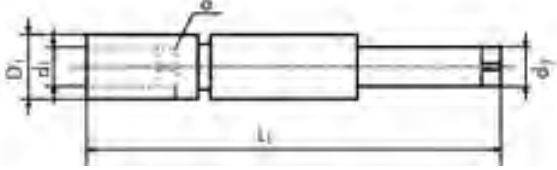
Удлинитель для метчиков
Przedłużki do gwintowników

D5830- D5840-		Удлинитель для метчиков по DIN 377. Przedłużki do gwintowników, zbliżone do DIN 377.		D5830-	D5840-		
							
No	a	L ₁	ID				
D5830-	mm	mm					
1	2.10	60	110571				
2	2.24	70	110572				
3	2.40	70	110573				
4	2.50	80	110574				
5	2.80	90	110575				
6	3.00	90	110579				
7	3.15	95	110580				
8	3.40	95	110581				
9	3.55	110	118706				
10	3.80	100	118707				
11	4.00	110	118708				
12	4.30	105	118709				
13	4.50	110	118710				
14	4.90	110	118711				
15	5.00	110	118712				
16	5.50	115	118713				
17	5.60	110	118714				
18	6.20	120	118715				
19	6.30	120	118716				
20	7.00	125	118717				
21	7.10	125	118718				
22	7.50	125	* 118719				
23	8.00	125	118720				
24	9.00	130	118721				
25	10.00	140	110562				
26	11.00	150	110563				
27	11.20	150	110564				
28	12.00	155	110565				
29	12.50	160	110566				
30	14.00	170	110567				
31	14.50	175	110568				
32	16.00	180	110569				
33	18.00	200	110570				
34	20.00	220	110576				
35	22.00	220	110577				
36	22.40	240	110578				
No	a	L ₁	d ₂	d ₁	D ₁	ID	
D5840-	mm	mm	mm	mm	mm		
1	4.90	130	6	6	12	142137	
2	5.50	130	7	7	13	142138	
3	6.20	130	8	8	13	142139	
4	7.00	130	9	9	17	142140	
5	8.00	130	10	10	17	142141	
6	9.00	130	11	11	17	142142	
7	9.00	130	12	12	20	142143	
8	11.00	130	14	14	20	142144	
9	12.00	130	16	16	25	142145	



ШКАЛА ТВЕРДОСТИ – TABELA TWARDOŚCI

HRC	HB	HV	N/mm ² Mpa
<i>Твердость по Роквеллу</i>	<i>Твердость по Бринеллю</i>	<i>Твердость по Викерсу</i>	<i>Предел прочности</i>
Twardość wg Rockwell'a	Twardość wg Brinell'a	Twardość wg Vickers'a	Wytrzymałość na rozciąganie
25	253	266	854
26	254	273	873
27	265	279	897
28	272	286	914
29	274	294	944
30	287	302	970
31	295	310	995
32	302	318	1024
33	311	327	1052
34	320	336	1082
35	329	345	1111
36	337	355	1139
37	346	364	1168
38	354	373	1198
39	363	382	1227
40	373	392	1262
41	382	402	1296
42	392	412	1327
43	402	423	1362
44	413	434	1401
45	424	446	1442
46	436	459	1481
47	448	471	1524
48	460	484	1572
49	474	499	1625
50	488	513	1668
51	502	528	1733
52	518	545	1793
53	532	560	1845
54	548	578	1912
55	566	596	1979
56	585	615	2050
57	603	634	2121
58		654	
59		675	
60		698	

Соответствие шкал твердости согласно DIN50150

Tabela przeliczeniowa dla wartości twardości, zgodna z DIN 50150

ДЮЙМЫ-ММ – CAL-ММ

Ø" d ₁	Ø mm	TPI UN											W(BSW)	BSF	G (BSP) Rp	Ø mm			
		UNC	UNF	UNEF	4	6	8	12	16	20	28	32							
0 1/16"	1.52 1.59		80											48		28	7.72		
1 2 3/32"	1.85 2.18 2.38	64 56	72 64																
3 4 5 1/8"	2.51 2.84 3.17 3.17 3.50	48 40 40 32	56 48 44 40											40		28	9.72		
5/32" 8 3/16" 10 12	3.96 4.16 4.76 4.82 5.48	32 32 24 24	36 36 32 28											32 24	32				
7/32" 1/4" 9/32" 5/16" 3/8"	5.55 6.35 7.14 7.93 9.52	20 18 16	28 24 24	32 32 32										24 20 16	28 26 20	19 19	13.15 16.66		
7/16" 1/2" 9/16" 5/8" 11/16"	11.11 12.70 14.28 15.87 17.46	14 13 12 11	20 20 18 18	28 28 24 24 24					16 16 12 12					32 32 28 28 32	14 12 12 11 14	18 16 16 14 14	14 14	20.95 22.91	
3/4" 13/16" 7/8" 15/16" 1"	19.05 20.64 22.22 23.81 25.40	10 9 8	16 14 12	20 20 20 20				12 12 12						28 28 28 28	32 32 32 32	10 9 8	12 12 11 10	14 14 11	26.44 30.20 33.24
1 1/16" 1 1/8" 1 3/16" 1 1/4" 1 5/16"	26.99 28.57 30.16 31.75 33.34	7 7	12 12	18 18 18 18			8 8 8 8	12 12 12	16 16 16	20 20 20 20	28 28 28 28			7 7	9 9	11 11	37.89 41.91		
1 3/8" 1 7/16" 1 1/2" 1 9/16" 1 5/8"	34.92 36.51 38.10 39.69 41.28	6 6	12 12	18 18 18 18		6 6	8 8 8 8	12 12 12	16 16 16	20 20 20	28 28			6 6 5	8 8 8	11 11	44.32 47.80		
1 11/16" 1 3/4" 1 13/16" 1 7/8" 1 15/16"	42.86 44.45 46.04 47.63 49.21	5		18		6 6 6 6	8 8 8 8	12 12 12	16 16 16	20 20 20				5 4 1/2	7	11	53.74		
2" 2 1/8" 2 1/4" 2 3/8" 2 1/2"	50.80 53.97 57.15 60.32 63.50	4 1/2 4 1/2 4				6 6 6 6	8 8 8 8	12 12 12	16 16 16	20 20 20				4 1/2 4 4	7 6 6	11 11 11	59.61 65.71 75.18		
2 5/8" 2 3/4" 2 7/8" 3" 3 1/8"	66.67 69.85 73.02 76.20 79.37	4 4 4				4 4 4	6 6 6 6	8 8 8	12 12 12	16 16 16 16	20 20 20			3 1/2 3 1/2	6 5	11 11	81.53 87.88		
3 1/4" 3 3/8" 3 1/2" 3 5/8" 3 3/4"	82.55 85.72 88.90 92.07 95.25	4 4 4				4 4	6 6 6	8 8 8	12 12 12	16 16 16				3 1/4 3 1/4 3	5 4 1/2 4 1/2	11 11 11	93.98 100.33 106.68		
3 7/8" 4"	98.42 101.60	4				4	6 6	8 8	12 12	16 16				3	4 1/2	11	113.03		



ПЕРЕВОДНАЯ ТАБЛИЦА – TABELA PRZELICZENIOWA

	Vc m/min																
	1	2	3	4	5	6	8	10	12	15	20	25	30	40	50	60	
	min ⁻¹																
Ø d ₁	1	318	637	955	1273	1592	1910	2546	3183	3820	4775	6366	7958	9549	12732	15915	19099
	2	159	318	477	637	796	955	1273	1592	1910	2387	3183	3979	4775	6366	7958	9549
3	106	212	318	424	531	637	849	1061	1273	1592	2122	2653	3183	4244	5305	6366	
	4	80	159	239	318	398	477	637	796	955	1194	1592	1989	2387	3183	3979	4775
5	64	127	191	255	318	382	509	637	764	955	1273	1592	1910	2546	3183	3820	
	6	53	106	159	212	265	318	424	531	637	796	1061	1326	1592	2122	2653	3183
8	40	80	119	159	199	239	318	398	477	597	796	995	1194	1592	1989	2387	
	10	32	64	95	127	159	191	255	318	382	477	637	796	955	1273	1592	1910
12	27	53	80	106	133	159	212	265	318	398	531	663	796	1061	1326	1592	
	14	23	45	68	91	114	136	182	227	273	341	455	568	682	909	1137	1364
16	20	40	60	80	99	119	159	199	239	298	398	497	597	796	995	1194	
	18	18	35	53	71	88	106	141	177	212	265	354	442	531	707	884	1061
20	16	32	48	64	80	95	127	159	191	239	318	398	477	637	796	955	
	25	13	25	38	51	64	76	102	127	153	191	255	318	382	509	637	764
30	11	21	32	42	53	64	85	106	127	159	212	265	318	424	531	637	
	35	9	18	27	36	45	55	73	91	109	136	182	227	273	364	455	546
40	8	16	24	32	40	48	64	80	95	119	159	199	239	318	398	477	
	45	7	14	21	28	35	42	57	71	85	106	141	177	212	283	354	424
50	6	13	19	25	32	38	51	64	76	95	127	159	191	255	318	382	

ОТВЕРСТИЯ ПОД РЕЗЬБЫ – ŚREDNICE OTWORÓW

M DIN 13, ISO 261, *5H / 6H

Ø	P	Внутренний диаметр гайки Średnica otworu			
		Ø mini	Ø maxi	Ø guide line	
d _i	mm				
* 1	0.25	0.729	0.785	0.75	
* 1.1	0.25	0.829	0.885	0.85	
* 1.2	0.25	0.929	0.985	0.95	
* 1.4	0.30	1.075	1.142	1.10	
1.6	0.35	1.221	1.321	1.25	
1.7	0.35	1.321	1.421	1.35	
1.8	0.35	1.421	1.521	1.45	
2	0.40	1.567	1.679	1.60	
2.2	0.45	1.713	1.838	1.75	
2.3	0.40	1.867	1.979	1.90	
2.5	0.45	2.013	2.138	2.05	
2.6	0.45	2.113	2.238	2.15	
3	0.50	2.459	2.599	2.50	
3.5	0.60	2.850	3.010	2.90	
4	0.70	3.242	3.422	3.30	
4.5	0.75	3.688	3.878	3.75	
5	0.80	4.134	4.334	4.20	
6	1.00	4.917	5.153	5.00	
7	1.00	5.917	6.153	6.00	
8	1.25	6.647	6.912	6.80	
9	1.25	7.647	7.912	7.80	
10	1.50	8.376	8.676	8.50	
11	1.50	9.376	9.676	9.50	
12	1.75	10.106	10.441	10.20	
14	2.00	11.835	12.210	12.00	
16	2.00	13.835	14.210	14.00	
18	2.50	15.294	15.744	15.50	
20	2.50	17.294	17.744	17.50	
22	2.50	19.294	19.744	19.50	
24	3.00	20.752	21.252	21.00	
27	3.00	23.752	24.252	24.00	
30	3.50	26.211	26.771	26.50	
33	3.50	29.211	29.771	29.50	
36	4.00	31.670	32.270	32.00	
39	4.00	34.670	35.270	35.00	
42	4.50	37.129	37.799	37.50	
45	4.50	40.129	40.799	40.50	
48	5.00	42.587	43.297	43.00	
52	5.00	46.587	47.297	47.00	
56	5.50	50.046	50.796	50.50	

MF DIN 13, ISO 261, 6H

Ø	P	Внутренний диаметр гайки Średnica otworu			
		Ø mini	Ø maxi	Ø guide line	
d _i	mm				
8	1.00	6.917	7.153	7.00	
9	0.75	8.188	8.378	8.25	
9	1.00	7.917	8.153	8.00	
10	0.75	9.188	9.378	9.25	
10	1.00	8.917	9.153	9.00	
10	1.25	8.647	8.912	8.80	
11	0.75	10.188	10.378	10.25	
11	1.00	9.917	10.153	10.00	
12	1.00	10.917	11.153	11.00	
12	1.25	10.647	10.912	10.80	
12	1.50	10.376	10.676	10.50	
14	1.00	12.917	13.153	13.00	
14	1.25	12.647	12.912	12.80	
14	1.50	12.376	12.676	12.50	
15	1.00	13.917	14.153	14.00	
15	1.50	13.376	13.676	13.50	
16	1.00	14.917	15.153	15.00	
16	1.50	14.376	14.676	14.50	
17	1.00	15.917	16.153	16.00	
17	1.50	15.376	15.676	15.50	
18	1.00	16.917	17.153	17.00	
18	1.50	16.376	16.676	16.50	
18	2.00	15.835	16.210	16.00	
20	1.00	18.917	19.153	19.00	
20	1.50	18.376	18.676	18.50	
20	2.00	17.835	18.210	18.00	
22	1.00	20.917	21.153	21.00	
22	1.50	20.376	20.676	20.50	
22	2.00	19.835	20.210	20.00	
24	1.00	22.917	23.153	23.00	
24	1.50	22.376	22.676	22.50	
24	2.00	21.835	22.210	22.00	
25	1.00	23.917	24.153	24.00	
25	1.50	23.376	23.676	23.50	
25	2.00	22.835	23.210	23.00	
27	1.50	25.376	25.676	25.50	
27	2.00	24.835	25.210	25.00	
28	1.00	26.917	27.153	27.00	
28	1.50	26.376	26.676	26.50	
28	2.00	25.835	26.210	26.00	
30	1.00	28.917	29.153	29.00	
30	1.50	28.376	28.676	28.50	
30	2.00	27.835	28.210	28.00	
32	1.50	30.376	30.676	30.50	
32	2.00	29.835	30.210	30.00	
33	1.50	31.376	31.676	31.50	
33	2.00	30.835	31.210	31.00	
35	1.50	33.376	33.676	33.50	
36	1.50	34.376	34.676	34.50	
36	2.00	33.835	34.210	34.00	
36	3.00	32.752	33.252	33.00	
39	1.50	37.376	37.676	37.50	
39	2.00	36.835	37.210	37.00	
39	3.00	35.752	36.252	36.00	
40	1.50	38.376	38.676	38.50	

MF DIN 13, ISO 261, 6H

Ø	P	Внутренний диаметр гайки Średnica otworu			
		Ø mini	Ø maxi	Ø guide line	
d _i	mm				
2.5	0.35	2.121	2.221	2.15	
3	0.35	2.621	2.721	2.65	
3.5	0.35	3.121	3.221	3.15	
4	0.50	3.459	3.599	3.50	
4.5	0.50	3.959	4.099	4.00	
5	0.50	4.459	4.599	4.50	
5.5	0.50	4.959	5.099	5.00	
6	0.75	5.188	5.378	5.25	
7	0.75	6.188	6.378	6.25	
8	0.75	7.188	7.378	7.25	



ОТВЕРСТИЯ ПОД РЕЗЬБЫ – ŚREDNICE OTWORÓW

MF DIN 13, ISO 261, 6H

Ø	P	Внутренний диаметр гайки Średnica otworu			
		Ø mini	Ø maxi	Ø guide line	
d ₁	mm				
40	2.00	37.835	38.210	38.00	
40	3.00	36.752	37.252	37.00	
42	1.50	40.376	40.676	40.50	
42	2.00	39.835	40.210	40.00	
42	3.00	38.752	39.252	39.00	
45	1.50	43.376	43.676	43.50	
45	2.00	42.835	43.210	43.00	
45	3.00	41.752	42.252	42.00	
48	1.50	46.376	46.676	46.50	
48	2.00	45.835	46.210	46.00	
48	3.00	44.752	45.252	45.00	
50	1.50	48.376	48.676	48.50	
50	2.00	47.835	48.210	48.00	
50	3.00	46.752	47.252	47.00	
52	1.50	50.376	50.676	50.50	
52	2.00	49.835	50.210	50.00	
52	3.00	48.752	49.252	49.00	
55	2.00	52.835	53.210	53.00	
60	2.00	57.835	58.210	58.00	

MF EN 60423:1994, 7H

Ø	P	Внутренний диаметр гайки Średnica otworu			
		Ø mini	Ø maxi	Ø guide line	
d ₁	mm				
8	1.00	6.917	7.217	7.00	
10	1.00	8.917	9.217	9.00	
12	1.50	10.376	10.751	10.50	
16	1.50	14.376	14.751	14.50	
20	1.50	18.376	18.751	18.50	
25	1.50	23.376	23.751	23.50	
32	1.50	30.376	30.751	30.50	
40	1.50	38.376	38.751	38.50	
63	1.50	61.376	61.751	61.50	

UNC ANSI B1.1, 2B

Ø	P	P	Внутренний диаметр гайки Średnica otworu			
			Ø mini	Ø maxi	Ø guide line	
d ₁	TPI	mm				
1	64	0.397	1.425	1.582	1.45	
2	56	0.454	1.695	1.871	1.75	
3	48	0.529	1.941	2.146	2.00	
4	40	0.635	2.157	2.385	2.25	
5	40	0.635	2.487	2.697	2.55	
6	32	0.794	2.642	2.895	2.75	
8	32	0.794	3.302	3.530	3.40	
10	24	1.058	3.683	3.962	3.80	
12	24	1.058	4.344	4.597	4.40	
1/4"	20	1.270	4.979	5.257	5.10	
5/16"	18	1.411	6.401	6.731	6.50	

UNC ANSI B1.1, 2B

Ø	P	P	Внутренний диаметр гайки Średnica otworu			
			Ø mini	Ø maxi	Ø guide line	
d ₁	TPI	mm				
3/8"	16	1.588	7.798	8.153	8.00	
7/16"	14	1.814	9.144	9.550	9.30	
1/2"	13	1.954	10.592	11.023	10.80	
9/16"	12	2.117	11.989	12.446	12.20	
5/8"	11	2.309	13.386	13.868	13.60	
3/4"	10	2.540	16.307	16.840	16.60	
7/8"	9	2.822	19.177	19.761	19.50	
1"	8	3.175	21.971	22.606	22.30	
1 1/8"	7	3.629	24.638	25.349	25.00	
1 1/4"	7	3.629	27.813	28.524	28.20	
1 3/8"	6	4.233	30.353	31.115	30.80	
1 1/2"	6	4.233	33.528	34.290	34.00	
1 3/4"	5	5.080	38.964	39.827	39.50	
2"	4.5	5.644	44.679	45.593	45.30	

UNJC ISO 3161:1999, 3B

Ø	P	P	Внутренний диаметр гайки Średnica otworu			
			Ø mini	Ø maxi	Ø guide line	
d ₁	TPI	mm				
4	40	0.635	2.228	2.393	2.30	
5	40	0.635	2.558	2.723	2.60	
6	32	0.794	2.733	2.939	2.80	
8	32	0.794	3.393	3.599	3.45	
10	24	1.058	3.795	4.064	3.90	
12	24	1.058	4.455	4.704	4.55	
1/4"	20	1.270	5.113	5.387	5.20	
5/16"	18	1.411	6.563	6.833	6.70	
3/8"	16	1.588	7.978	8.255	8.10	
7/16"	14	1.814	9.347	9.639	9.40	
1/2"	13	1.954	10.798	11.095	10.90	
9/16"	12	2.117	12.228	12.482	12.40	
5/8"	11	2.309	13.627	13.904	13.80	
3/4"	10	2.540	16.576	16.881	16.70	

ОТВЕРСТИЯ ПОД РЕЗЬБЫ – ŚREDNICE OTWORÓW

UNF ANSI B1.1, 2B

Ø	P	P	Внутренний диаметр гайки		
			Średnica otworu	Ø mini	Ø maxi
d _i	TPI	mm			
0	80	0.318	1.182	1.305	1.20
1	72	0.353	1.474	1.612	1.50
2	64	0.397	1.756	1.912	1.80
3	56	0.454	2.025	2.197	2.10
4	48	0.529	2.271	2.458	2.35
5	44	0.577	2.551	2.740	2.60
6	40	0.635	2.820	3.022	2.90
8	36	0.706	3.404	3.606	3.50
10	32	0.794	3.963	4.165	4.05
12	28	0.907	4.496	4.724	4.60
1/4"	28	0.907	5.360	5.588	5.50
5/16"	24	1.058	6.782	7.035	6.90
3/8"	24	1.058	8.382	8.636	8.50
7/16"	20	1.270	9.729	10.033	9.80
1/2"	20	1.270	11.329	11.607	11.40
9/16"	18	1.411	12.751	13.081	12.90
5/8"	18	1.411	14.351	14.681	14.50
3/4"	16	1.588	17.323	17.678	17.30
7/8"	14	1.814	20.270	20.675	20.40
1"	12	2.117	23.114	23.571	23.30
1 1/8"	12	2.117	26.289	26.746	26.50
1 1/4"	12	2.117	29.464	29.921	29.70
1 3/8"	12	2.117	32.639	33.096	32.80
1 1/2"	12	2.117	35.814	36.271	36.00

UNJF ISO 3161:1999, 3B

Ø	P	P	Внутренний диаметр гайки		
			Średnica otworu	Ø mini	Ø maxi
d _i	TPI	mm			
0	80	0.318	1.217	1.298	1.25
1	72	0.353	1.511	1.603	1.55
2	64	0.397	1.798	1.902	1.85
3	56	0.454	2.073	2.189	2.15
4	48	0.529	2.329	2.466	2.35
5	44	0.577	2.614	2.764	2.70
6	40	0.635	2.888	3.053	2.95
8	36	0.706	3.480	3.663	3.60
10	32	0.794	4.054	4.255	4.10
12	28	0.907	4.602	4.816	4.70
1/4"	28	0.907	5.466	5.662	5.55
5/16"	24	1.058	6.906	7.109	7.00
3/8"	24	1.058	8.494	8.679	8.60
7/16"	20	1.270	9.876	10.084	10.00
1/2"	20	1.270	11.463	11.661	11.55
9/16"	18	1.411	12.913	13.122	13.05
5/8"	18	1.411	14.501	14.702	14.60
3/4"	16	1.588	17.506	17.722	17.60
7/8"	14	1.814	20.460	20.706	20.50
1"	12	2.117	23.340	23.594	23.40

UNEF ANSI B1.1, 2B

Ø	P	P	Внутренний диаметр гайки		
			Średnica otworu	Ø mini	Ø maxi
d _i	TPI	mm			
12	32	0.794	4.623	4.826	4.70
1/4"	32	0.794	5.487	5.689	5.60
5/16"	32	0.794	7.087	7.264	7.20
3/8"	32	0.794	8.662	8.864	8.75
7/16"	28	0.907	10.135	10.337	10.25
1/2"	28	0.907	11.710	11.938	11.85
9/16"	24	1.058	13.132	13.385	13.20
5/8"	24	1.058	14.732	14.986	14.80
11/16"	24	1.058	16.307	16.560	16.40
3/4"	20	1.270	17.679	17.957	17.80
13/16"	20	1.270	19.254	19.558	19.40
7/8"	20	1.270	20.854	21.132	21.00
1"	20	1.270	24.029	24.307	24.10

UN ANSI B1.1, 2B

Ø	P	P	Внутренний диаметр гайки		
			Średnica otworu	Ø mini	Ø maxi
d _i	TPI	mm			
5/16"	20	1.270	6.554	6.858	6.70
3/8"	20	1.270	8.154	8.432	8.30
9/16"	20	1.270	12.904	13.208	13.00
5/8"	20	1.270	14.504	14.782	14.60
1 1/8"	8	3.175	25.146	25.781	25.50
1 1/4"	8	3.175	28.321	28.956	28.70
1 3/8"	8	3.175	31.496	32.131	31.80
1 1/2"	8	3.175	34.671	35.306	35.00
1 5/8"	8	3.175	37.846	38.481	38.20
1 3/4"	8	3.175	41.021	41.656	41.40
1 7/8"	8	3.175	44.196	44.831	44.50
2"	8	3.175	47.371	48.006	47.70
2 1/4"	8	3.175	53.721	54.356	54.10
2 1/2"	8	3.175	60.071	60.706	60.40



ОТВЕРСТИЯ ПОД РЕЗЬБЫ – ŚREDNICE OTWORÓW

UNS ANSI B1.1, 2B

Ø	P	P	Внутренний диаметр гайки		
			Średnica otworu		
d _i	TPI	mm	Ø mini	Ø maxi	Ø guide line
10	36	0.706	4.064	4.216	4.10
10	40	0.635	4.141	4.292	4.20
10	56	0.454	4.344	4.445	4.40
1/4"	36	0.706	5.588	5.740	5.65
1/4"	40	0.635	5.665	5.816	5.70
1/4"	48	0.529	5.766	5.892	5.80
1/4"	56	0.454	5.868	5.969	5.90
5/16"	36	0.706	7.163	7.340	7.25
3/8"	36	0.706	8.763	8.940	8.80
7/16"	24	1.058	9.957	10.210	10.00
1/2"	24	1.058	11.557	11.811	11.60
1"	14	1.814	23.445	23.825	23.60

W (BSW) BS 84, (DIN11 - 1970)

Ø	P	P	Внутренний диаметр гайки		
			Średnica otworu		
d _i	TPI	mm	Ø mini	Ø maxi	Ø guide line
(3/32")	48				1.80
1/8"	40	0.635	2.362	2.591	2.50
(5/32")	32				3.10
3/16"	24	1.058	3.406	3.744	3.60
(7/32")	24				4.40
1/4"	20	1.270	4.724	5.156	5.10
5/16"	18	1.411	6.129	6.588	6.50
3/8"	16	1.588	7.493	7.988	7.90
7/16"	14	1.814	8.791	9.332	9.20
1/2"	12	2.117	9.987	10.589	10.50
5/8"	11	2.309	12.918	13.558	13.50
3/4"	10	2.540	15.799	16.484	16.25
7/8"	9	2.822	18.613	19.355	19.25
1"	8	3.175	21.336	22.149	21.90

G (BSP) DIN ISO 228

Ø	P	P	Внутренний диаметр гайки		
			Średnica otworu		
d _i	TPI	mm	Ø mini	Ø maxi	Ø guide line
1/16"	28	0.907	6.561	6.843	6.75
1/8"	28	0.907	8.566	8.848	8.75
1/4"	19	1.337	11.445	11.890	11.60
3/8"	19	1.337	14.950	15.395	15.20
1/2"	14	1.814	18.631	19.172	18.90
5/8"	14	1.814	20.587	21.128	20.90
3/4"	14	1.814	24.117	24.658	24.40
7/8"	14	1.814	27.877	28.418	28.20
1"	11	2.309	30.291	30.931	30.70
1 1/8"	11	2.309	34.939	35.579	35.30
1 1/4"	11	2.309	38.952	39.592	39.30
1 3/8"	11	2.309	41.365	42.005	41.80
1 1/2"	11	2.309	44.845	45.485	45.20
1 3/4"	11	2.309	50.788	51.428	51.20
2"	11	2.309	56.656	57.296	57.00
2 1/4"	11	2.309	62.752	63.392	63.10
2 1/2"	11	2.309	72.226	72.866	72.60
3"	11	2.309	84.926	85.566	85.30

PG DIN 40430

Ø	P	P	Внутренний диаметр гайки		
			Średnica otworu		
d _i	TPI	mm	Ø mini	Ø maxi	Ø guide line
7	20	1.270	11.28	11.43	11.35
9	18	1.411	13.86	14.01	13.90
11	18	1.411	17.26	17.41	17.30
13.5	18	1.411	19.06	19.21	19.10
16	18	1.411	21.16	21.31	21.20
21	16	1.588	26.78	27.03	26.80
29	16	1.588	35.48	35.73	35.50
36	16	1.588	45.48	45.73	45.50
42	16	1.588	52.48	52.73	52.50
48	16	1.588	57.78	58.03	57.80

TR ISO 2901-2904, DIN 103, 7H

Ø	P	Внутренний диаметр гайки		
		Średnica otworu		
d _i	mm	Ø mini	Ø maxi	Ø guide line
10	2	8	8.236	8.20
12	3	9	9.315	9.25
14	3	11	11.315	11.25
16	4	12	12.375	12.25
18	4	14	14.375	14.25
20	4	16	16.375	16.25
22	5	17	17.450	17.25
24	5	19	19.450	19.25
26	5	21	21.450	21.25
28	5	23	23.450	23.25
30	6	24	24.500	24.25
32	6	26	26.500	26.25

ДИАМЕТРЫ ПОД ПЛАШКИ – ŚREDNICE WAŁKÓW

M DIN 13, ISO 261, *6h / 6g

Ø	P	Наружный диаметр резьбы Średnica zewnętrzna		
		Ø mini	Ø maxi	Ø guide line
d _i	mm			
* 1	0.25	0.933	1.000	0.97
* 1.1	0.25	1.033	1.100	1.07
* 1.2	0.25	1.133	1.200	1.17
* 1.4	0.30	1.325	1.400	1.36
1.6	0.35	1.496	1.581	1.54
1.7	0.35	1.596	1.681	1.64
1.8	0.35	1.696	1.781	1.74
2	0.40	1.886	1.981	1.93
2.2	0.45	2.080	2.180	2.13
2.3	0.40	2.186	2.300	2.23
2.5	0.45	2.380	2.480	2.43
2.6	0.45	2.480	2.600	2.53
3	0.50	2.874	2.980	2.92
3.5	0.60	3.354	3.479	3.41
4	0.70	3.838	3.978	3.91
4.5	0.75	4.338	4.478	4.41
5	0.80	4.826	4.976	4.90
6	1.00	5.794	5.974	5.88
7	1.00	6.794	6.974	6.88
8	1.25	7.760	7.972	7.87
9	1.25	8.760	8.972	8.87
10	1.50	9.732	9.968	9.85
11	1.50	10.732	10.968	10.85
12	1.75	11.701	11.966	11.83
14	2.00	13.682	13.962	13.82
16	2.00	15.682	15.962	15.82
18	2.50	17.623	17.958	17.79
20	2.50	19.623	19.958	19.79
22	2.50	21.623	21.958	21.79
24	3.00	23.577	23.952	23.76
27	3.00	26.577	26.952	26.76
30	3.50	29.522	29.947	29.73
33	3.50	32.522	32.947	32.73
36	4.00	35.465	35.940	35.70
39	4.00	38.465	38.940	38.70
42	4.50	41.437	41.937	41.69
45	4.50	44.437	44.937	44.69
48	5.00	47.399	47.929	47.66
52	5.00	51.399	51.929	51.66
56	5.50	55.365	55.925	55.65

MF DIN 13, ISO 261, 6g

Ø	P	Наружный диаметр резьбы Średnica zewnętrzna		
		Ø mini	Ø maxi	Ø guide line
d _i	mm			
8	1.00	7.794	7.974	7.88
9	0.75	8.838	8.978	8.90
9	1.00	8.794	8.974	8.88
10	0.75	9.838	9.978	9.90
10	1.00	9.794	9.974	9.88
10	1.25	9.760	9.972	9.86
11	0.75	10.838	10.978	10.91
11	1.00	10.794	10.974	10.88
12	1.00	11.794	11.974	11.88
12	1.25	11.760	11.972	11.86
12	1.50	11.732	11.968	11.85
14	1.00	13.794	13.974	13.88
14	1.25	13.760	13.972	13.86
14	1.50	13.732	13.968	13.85
15	1.00	14.794	14.974	14.88
15	1.50	14.732	14.968	14.85
16	1.00	15.794	15.974	15.88
16	1.50	15.732	15.968	15.85
17	1.00	16.794	16.974	16.88
17	1.50	16.732	16.968	16.85
18	1.00	17.794	17.974	17.88
18	1.50	17.732	17.968	17.85
18	2.00	17.682	17.962	17.82
20	1.00	19.794	19.974	19.88
20	1.50	19.732	19.968	19.85
20	2.00	19.682	19.962	19.82
22	1.00	21.794	21.974	21.88
22	1.50	21.732	21.968	21.85
22	2.00	21.682	21.962	21.82
24	1.00	23.794	23.974	23.88
24	1.50	23.732	23.968	23.85
24	2.00	23.682	23.962	23.82
25	1.00	24.794	24.974	24.88
25	1.50	24.732	24.968	24.85
25	2.00	24.682	24.962	24.82
27	1.00	26.794	26.974	26.88
27	1.50	26.732	26.968	26.85
27	2.00	26.682	26.962	26.82
28	1.00	27.794	27.974	27.88
28	1.50	27.732	27.968	27.85
28	2.00	27.682	27.962	27.82
30	1.00	29.794	29.974	29.88
30	1.50	29.732	29.968	29.85
30	2.00	29.682	29.962	29.82
30	3.00	29.577	29.952	29.76
32	1.50	31.732	31.968	31.85
32	2.00	31.682	31.962	31.82
33	1.50	32.732	32.968	32.85
33	2.00	32.682	32.962	32.82
33	3.00	32.577	32.952	32.76
35	1.50	34.732	34.968	34.85
36	1.50	35.732	35.968	35.85
36	2.00	35.682	35.962	35.82
36	3.00	35.577	35.952	35.76
39	1.50	38.732	38.968	38.85
39	2.00	38.682	38.962	38.82
39	3.00	38.577	38.952	38.76

MF DIN 13, ISO 261, 6g

Ø	P	Наружный диаметр резьбы Średnica zewnętrzna		
		Ø mini	Ø maxi	Ø guide line
d _i	mm			
2.5	0.35	2.396	2.481	2.44
3	0.35	2.896	2.981	2.94
3.5	0.35	3.396	3.481	3.44
4	0.50	3.874	3.980	3.93
4.5	0.50	4.374	4.480	4.43
5	0.50	4.874	4.980	4.93
5.5	0.50	5.374	5.480	5.43
6	0.75	5.838	5.978	5.91
7	0.75	6.838	6.978	6.90
8	0.75	7.838	7.978	7.90



ДИАМЕТРЫ ПОД ПЛАШКИ – ŚREDNICE WAŁKÓW

MF DIN 13, ISO 261, 6g

Ø	P	Наружный диаметр резьбы Średnica zewnętrzna			
		Ø mini	Ø maxi	Ø guide line	
d ₁	mm				
40	1.50	39.732	39.968	39.85	
40	2.00	39.682	39.962	39.82	
40	3.00	39.577	39.952	39.76	
42	1.50	41.732	41.968	41.85	
42	2.00	41.682	41.962	41.82	
42	3.00	41.577	41.952	41.76	
45	1.50	44.732	44.968	44.85	
45	2.00	44.682	44.962	44.82	
45	3.00	44.577	44.952	44.76	
48	1.50	47.732	47.968	47.85	
48	2.00	47.682	47.962	47.82	
48	3.00	47.577	47.952	47.76	
50	1.50	49.732	49.968	49.85	
50	2.00	49.682	49.962	49.82	
50	3.00	49.577	49.952	49.76	
52	1.50	51.732	51.968	51.85	
52	2.00	51.682	51.962	51.82	
52	3.00	51.577	51.952	51.76	
52	4.00	51.465	51.940	51.70	

UNC ANSI B1.1, 2A

Ø	P	Наружный диаметр резьбы Średnica zewnętrzna			
		Ø mini	Ø maxi	Ø guide line	
d ₁	mm				
1	64	0.397	1.743	1.838	1.79
2	56	0.454	2.066	2.169	2.12
3	48	0.529	2.383	2.496	2.44
4	40	0.635	2.695	2.824	2.76
5	40	0.635	3.026	3.154	3.09
6	32	0.794	3.333	3.484	3.41
8	32	0.794	3.991	4.142	4.07
10	24	1.058	4.618	4.800	4.71
12	24	1.058	5.279	5.461	5.37
1/4"	20	1.270	6.117	6.322	6.22
5/16"	18	1.411	7.687	7.907	7.80
3/8"	16	1.588	9.254	9.491	9.37
7/16"	14	1.814	10.816	11.076	10.95
1/2"	13	1.954	12.386	12.661	12.52
9/16"	12	2.117	13.958	14.246	14.10
5/8"	11	2.309	15.528	15.834	15.68
3/4"	10	2.540	18.677	19.004	18.84
7/8"	9	2.822	21.824	22.176	22.00
1"	8	3.175	24.969	25.349	25.16
1 1/8"	7	3.629	28.103	28.519	28.31
1 1/4"	7	3.629	31.278	31.694	31.49
1 3/8"	6	4.233	34.402	34.864	34.63
1 1/2"	6	4.233	37.577	38.039	37.81
1 3/4"	5	5.080	43.860	44.381	44.12
2"	4.5	5.644	50.168	50.726	50.45
2 1/4"	4.5	5.644	56.518	57.076	56.80
2 1/2"	4	6.350	62.817	63.421	63.12
2 3/4"	4	6.350	69.165	69.768	69.47
3"	4	6.350	75.515	76.118	75.82
3 1/4"	4	6.350	81.862	82.466	82.16
3 1/2"	4	6.350	88.212	88.816	88.51

UNC ANSI B1.1, 2A

Ø	P	P	Наружный диаметр резьбы Średnica zewnętrzna			
			Ø mini	Ø maxi	Ø guide line	
d ₁	TPI	mm				
3 3/4"	4	6.350	94.560	95.163	94.86	
4"	4	6.350	100.910	101.513	101.21	

UNF ANSI B1.1, 2A

Ø	P	P	Наружный диаметр резьбы Średnica zewnętrzna			
			Ø mini	Ø maxi	Ø guide line	
d ₁	TPI	mm				
0	80	0.318	1.431	1.511	1.47	
1	72	0.353	1.751	1.838	1.79	
2	64	0.397	2.073	2.169	2.12	
3	56	0.454	2.393	2.496	2.44	
4	48	0.529	2.713	2.827	2.77	
5	44	0.577	3.036	3.157	3.10	
6	40	0.635	3.356	3.484	3.42	
8	36	0.706	4.006	4.145	4.08	
10	32	0.794	4.651	4.803	4.73	
12	28	0.907	5.296	5.461	5.38	
1/4"	28	0.907	6.160	6.324	6.24	
5/16"	24	1.058	7.727	7.909	7.82	
3/8"	24	1.058	9.315	9.497	9.41	
7/16"	20	1.270	10.874	11.079	10.98	
1/2"	20	1.270	12.462	12.666	12.56	
9/16"	18	1.411	14.031	14.251	14.14	
5/8"	18	1.411	15.619	15.839	15.73	
3/4"	16	1.588	18.774	19.011	18.89	
7/8"	14	1.814	21.923	22.184	22.05	
1"	12	2.117	25.065	25.354	25.21	
1 1/8"	12	2.117	28.240	28.529	28.38	
1 1/4"	12	2.117	31.415	31.704	31.56	
1 3/8"	12	2.117	34.588	34.876	34.73	
1 1/2"	12	2.117	37.763	38.051	37.91	

UNEF ANSI B1.1, 2A

Ø	P	P	Наружный диаметр резьбы Średnica zewnętrzna			
			Ø mini	Ø maxi	Ø guide line	
d ₁	TPI	mm				
12	32	0.794	5.312	5.463	5.39	
1/4"	32	0.794	6.173	6.324	6.25	
5/16"	32	0.794	7.760	7.912	7.84	
3/8"	32	0.794	9.348	9.499	9.42	
7/16"	28	0.907	10.920	11.084	11.00	
1/2"	28	0.907	12.507	12.672	12.59	
9/16"	24	1.058	14.075	14.257	14.17	
5/8"	24	1.058	15.662	15.844	15.75	
11/16"	24	1.058	17.250	17.432	17.34	
3/4"	20	1.270	18.812	19.016	18.91	
13/16"	20	1.270	20.339	20.604	20.50	
7/8"	20	1.270	21.987	22.191	22.09	
15/16"	20	1.270	23.572	23.776	23.67	
1"	20	1.270	25.159	25.364	25.26	
1 1/8"	18	1.411	28.319	28.539	28.43	
1 1/4"	18	1.411	31.491	31.711	31.60	
1 1/2"	18	1.411	37.841	38.061	37.95	

ДИАМЕТРЫ ПОД ПЛАШКИ – ŚREDNICE WAŁKÓW

UN ANSI B1.1, 2A

Ø	P	P	Наружный диаметр резьбы			
			Średnica zewnętrzna			
d _i	TPI	mm	Ø mini	Ø maxi	Ø guide line	
5/16"	20	1.270	7.702	7.907	7.80	
3/8"	20	1.270	9.289	9.494	9.39	
9/16"	20	1.270	14.049	14.254	14.15	
5/8"	20	1.270	15.637	15.841	15.74	
1 1/8"	8	3.175	28.141	28.521	28.33	
1 1/4"	8	3.175	31.316	31.696	31.51	
1 3/8"	8	3.175	34.489	34.869	34.68	
1 1/2"	8	3.175	37.664	38.044	37.85	
1 5/8"	8	3.175	40.839	41.219	41.03	
1 3/4"	8	3.175	44.011	44.391	44.20	
1 7/8"	8	3.175	47.186	47.566	47.38	
2"	8	3.175	50.361	50.741	50.55	
2 1/4"	8	3.175	56.709	57.089	56.90	
2 1/2"	8	3.175	63.059	63.439	63.25	
2 3/4"	8	3.175	69.406	69.786	69.60	
3"	8	3.175	75.753	76.133	75.94	

W (BSW) BS 84

Ø	P	P	Наружный диаметр резьбы			
			Średnica zewnętrzna			
d _i	TPI	mm	Ø mini	Ø maxi	Ø guide line	
1/4"	20	1.270	6.165	6.319	6.24	
5/16"	18	1.411	7.737	7.904	7.82	
3/8"	16	1.588	9.312	9.489	9.40	
7/16"	14	1.814	10.884	11.074	10.98	
1/2"	12	2.117	12.456	12.662	12.56	
5/8"	11	2.309	15.613	15.832	15.72	
3/4"	10	2.540	18.771	19.004	18.89	
7/8"	9	2.822	21.979	22.225	22.10	
1"	8	3.175	25.138	25.400	25.27	
1 1/8"	7	3.629	28.296	28.575	28.44	
1 1/4"	7	3.629	31.465	31.750	31.61	
1 1/2"	6	4.233	37.793	38.100	37.95	
1 3/4"	5	5.080	44.117	44.450	44.28	
2"	4.5	5.644	50.449	50.800	50.62	
2 1/4"	4	6.350	56.779	57.150	56.96	
2 1/2"	4	6.350	63.119	63.500	63.31	

UNS ANSI B1.1, 2A

Ø	P	P	Наружный диаметр резьбы			
			Średnica zewnętrzna			
d _i	TPI	mm	Ø mini	Ø maxi	Ø guide line	
10	36	0.706	4.664	4.803	4.73	
10	40	0.635	4.674	4.803	4.74	
10	56	0.454	4.705	4.808	4.76	
1/4"	36	0.706	6.188	6.327	6.26	
1/4"	40	0.635	6.198	6.327	6.26	
1/4"	48	0.529	6.216	6.329	6.27	
1/4"	56	0.454	6.226	6.329	6.28	
5/16"	36	0.706	7.775	7.914	7.84	
3/8"	36	0.706	9.360	9.499	9.43	
7/16"	24	1.058	10.902	11.084	10.99	
1/2"	24	1.058	12.487	12.669	12.58	
1"	14	1.814	25.096	25.356	25.23	

PG DIN 40430

Ø	P	P	Наружный диаметр резьбы			
			Średnica zewnętrzna			
d _i	TPI	mm	Ø mini	Ø maxi	Ø guide line	
7	20	1.270	12.3	12.5	12.40	
9	18	1.411	15.0	15.2	15.10	
11	18	1.411	18.4	18.6	18.50	
13.5	18	1.411	20.2	20.4	20.30	
16	18	1.411	22.3	22.5	22.40	
21	16	1.588	28.0	28.3	28.15	
29	16	1.588	36.7	37.0	36.85	
36	16	1.588	46.7	47.0	46.85	
42	16	1.588	53.7	54.0	53.85	
48	16	1.588	59.0	59.3	59.15	

G (BSP) DIN ISO 228

Ø	P	P	Наружный диаметр резьбы			
			Średnica zewnętrzna			
d _i	TPI	mm	Ø mini	Ø maxi	Ø guide line	
1/16"	28	0.907	7.509	7.723	7.62	
1/8"	28	0.907	9.514	9.728	9.62	
1/4"	19	1.337	12.907	13.157	13.03	
3/8"	19	1.337	16.412	16.662	16.54	
1/2"	14	1.814	20.671	20.955	20.81	
5/8"	14	1.814	22.627	22.911	22.77	
3/4"	14	1.814	26.157	26.441	26.30	
7/8"	14	1.814	29.917	30.201	30.06	
1"	11	2.309	32.889	33.249	33.07	
1 1/8"	11	2.309	37.537	37.897	37.72	
1 1/4"	11	2.309	41.550	40.910	41.73	
1 3/8"	11	2.309	43.963	44.323	44.14	
1 1/2"	11	2.309	47.443	47.803	47.62	
1 3/4"	11	2.309	53.386	53.746	53.57	
2"	11	2.309	59.254	59.614	59.43	
2 1/4"	11	2.309	65.276	65.710	65.49	
2 1/2"	11	2.309	74.750	75.184	74.97	
2 3/4"	11	2.309	81.100	81.534	81.32	
3"	11	2.309	87.450	87.884	87.67	
3 1/2"	11	2.309	99.896	100.330	100.11	

TR ISO 2901-2904, DIN 103, 7e

Ø	P	Наружный диаметр резьбы			
		Średnica zewnętrzna			
d _i	mm	Ø mini	Ø maxi	Ø guide line	
10	2	9.820	10.000	9.91	
12	3	11.764	12.000	11.88	
14	3	13.764	14.000	13.88	
16	4	15.700	16.000	15.85	
18	4	17.700	18.000	17.85	
20	4	19.700	20.000	19.85	
22	5	21.665	22.000	21.83	
24	5	23.665	24.000	23.83	
26	5	25.665	26.000	25.83	
28	5	27.665	28.000	27.83	
30	6	29.625	30.000	29.81	
32	6	31.625	32.000	31.81	



Запрос <input type="checkbox"/>	Результат испытаний <input type="checkbox"/>	Претензии <input type="checkbox"/>
<p>Агент : _____ Контактное лицо : _____ Потребитель : _____ E-Mail : _____ Телефон или факс : _____ Дата : _____</p>		
<p>1. Тип инструмента : _____ Размер резьбы : _____ Частности : _____ Класс точности : _____</p>		
<p>2. Группа материалов : _____ № материала : _____ Тведость : _____ N/mm² /HB/HRC Стандарт : _____ Удлинение : _____ %</p>		
<p>3. Резьба : <input type="checkbox"/> Глухое <input type="checkbox"/> Сквозное Длина нарезания резьбы : _____ mm Диаметр отверстия под резьбу : _____ Глубина : _____ mm Диаметр зенкера : _____ Глубина : _____ mm</p>		
<p>4. Скорость резания : _____ m/min _____ 1/min Подача (f) : _____ %</p>		
<p>5. Станок : _____ <input type="checkbox"/> Внутренняя подача СОЖ Рабочее положение : <input type="checkbox"/> Горизонтальное <input type="checkbox"/> Вертикальное Скоростное <input type="checkbox"/> Патрон с плавающим осевым амортизатором SRT Тип патрона : <input type="checkbox"/> Осевая компенсация нарезание <input type="checkbox"/> Велдон <input type="checkbox"/> Патрон с предохранительной муфтой резьбы с ЧПУ : <input type="checkbox"/> Weldon <input type="checkbox"/> Реверсивный <input type="checkbox"/> Горячий/холодный термпатрон <input type="checkbox"/> Скользящая муфта</p>		
<p>6. Смазка : <input type="checkbox"/> Эмульсия <input type="checkbox"/> Масло <input type="checkbox"/> Воздух <input type="checkbox"/> Аэрозоль Наименование : _____</p>		
<p>7. Причина замены инструмента : <input type="checkbox"/> Износ инструмента <input type="checkbox"/> Поломка инструмента <input type="checkbox"/> Несоответствие резьбы калибру <input type="checkbox"/> Поломка в заходной части <input type="checkbox"/> Ошибка станка <input type="checkbox"/> Поломка в резьбовой части</p>		
<p>8. Сравнение эффективности Испытываемый инструмент : _____ Результаты и замечания : _____</p>		
<p>Примечания : _____ _____</p>		

Zapytanie <input type="checkbox"/>	Wyniki testów <input type="checkbox"/>	Reklamacja <input type="checkbox"/>
Dystrybutor : _____ Klient : _____ Telefon lub faks: _____		Kontakt : _____ E-mail : _____ Data : _____
1. Typ narzędzia : _____ Szczególny : _____		Wielkość gwintu : _____ Tolerancja wykonania : _____
2. Grupa materiałowa : _____ Materiał nr. : _____ Norma : _____		Twardość : _____ N/mm ² /HB/HRC Wydłużenie : _____ %
3. Gwint : <input type="checkbox"/> Otwór ślepy <input type="checkbox"/> Otwór przelotowy Średnica otworu : _____ Głębokość : _____ mm Średnica nawiercenia : _____ Głębokość : _____ mm		Długość gwintu : _____ mm
4. Prędkość skrawania(V_c) : _____ m/min Posuw (f) : _____ %		_____ 1/min
5. Obrabiarka : _____ Układ pracy : <input type="checkbox"/> układ poziomy <input type="checkbox"/> układ pionowy Gwintowanie na sztywno : <input type="checkbox"/> „Miękkie gwintowanie na sztywno“ <input type="checkbox"/> Tulejka <input type="checkbox"/> Weldon <input type="checkbox"/> Mocowanie termiczne		<input type="checkbox"/> Chłodzenie wewnętrzne Wrzeciono gwintujące : <input type="checkbox"/> Kompensacja osiowa <input type="checkbox"/> Wysprężnianie <input type="checkbox"/> Rewersyjny <input type="checkbox"/> Sprzęgło ślizgowe
6. Chłodziwo : <input type="checkbox"/> Emulsja <input type="checkbox"/> Olej Produkt : _____		<input type="checkbox"/> Powietrze <input type="checkbox"/> Mgła olejowa
7. Powód zmiany narzędzia : <input type="checkbox"/> Zużycie narzędzia <input type="checkbox"/> Gwint wykonany nieprawidłowo (sprawdzony sprawdzianem) <input type="checkbox"/> Błąd obrabiarki		<input type="checkbox"/> Zniszczenie narzędzia <input type="checkbox"/> Wyłamanie zębów w zwojach wprowadzających <input type="checkbox"/> Wyłamanie zębów w zwojach nacinających
8. Porównanie wydajności Narzędzie w trakcie testów : _____ Wyniki i obserwacje : _____		
Uwagi : _____ _____		

Запрос <input type="checkbox"/>	Результат испытаний <input type="checkbox"/>	Претензии <input type="checkbox"/>
Агент : _____		Контактное лицо : _____
Потребитель : _____		E-Mail : _____
Телефон или факс : _____		Дата : _____
<hr/>		
1. Тип инструмента : _____		
Диаметр инструмента : _____		Шаг резьбы : _____
Серия : _____		Покрытие : _____
<hr/>		
2. Группа материалов : _____		
№ материала : _____		Тведость : _____ N/mm ² /HB/HRC
Стандарт : _____		Удлинение : _____ %
<hr/>		
3. Резьба : <input type="checkbox"/> Внутренняя <input type="checkbox"/> Внешняя		
Отверстие : <input type="checkbox"/> Глухое <input type="checkbox"/> Сквозное		
Длина нарезаемой резьбы : _____ mm		
Диаметр отверстия под резьбу : _____		Глубина : _____ mm
Диаметр зенкера : _____		Глубина : _____ mm
<hr/>		
4. Скорость резания : _____ m/min _____ 1/min		
Подача (f) : _____ %		Подача (f _z) : _____ (мм/зуб)
<hr/>		
5. Станок : _____ <input type="checkbox"/> Внутренняя подача СОЖ		
Рабочее положение : <input type="checkbox"/> Горизонтальное <input type="checkbox"/> Вертикальное		
Крепление инструмента : <input type="checkbox"/> Цанга <input type="checkbox"/> Weldon / Whistle Notch		
<input type="checkbox"/> Гидравлический патрон <input type="checkbox"/> Скользящая муфта		
<hr/>		
6. Смазка : <input type="checkbox"/> Эмульсия <input type="checkbox"/> Масло <input type="checkbox"/> Воздух <input type="checkbox"/> Аэрозоль		
Наименование : _____		
<hr/>		
7. Причина замены инструмента : <input type="checkbox"/> Износ инструмента <input type="checkbox"/> Поломка инструмента		
<input type="checkbox"/> Несоответствие резьбы калибру <input type="checkbox"/> Ошибка станка		
<hr/>		
8. Сравнение эффективности		
Испытываемый инструмент : _____		
Результаты и замечания : _____		

<hr/>		
Примечания : _____		

Zapytanie <input type="checkbox"/>	Wyniki testów <input type="checkbox"/>	Reklamacja <input type="checkbox"/>
Dystrybutor : _____	Kontakt : _____	
Klient : _____	E-mail : _____	
Telefon lub faks: _____	Data : _____	
<hr/>		
1. Typ narzędzia : _____	Skok gwintu : _____	
Średnica narzędzia : _____	Powłoka : _____	
Seria : _____		
<hr/>		
2. Grupa materiałowa : _____		
Materiał nr. : _____	Twardość : _____ N/mm ² /HB/HRC	
Norma : _____	Wydłużenie : _____ %	
<hr/>		
3. Gwint : <input type="checkbox"/> Wewnętrzny <input type="checkbox"/> Zewnętrzny	Otwór : <input type="checkbox"/> Otwór ślepy <input type="checkbox"/> Otwór przelotowy	
Długość gwintu : _____ mm		
Średnica otworu : _____	Głębokość : _____ mm	
Średnica nawiercenia : _____	Głębokość : _____ mm	
<hr/>		
4. Prędkość skrawania (V_c) : _____ m/min _____ 1/min		
Posuw (f) : _____ mm/obr.	Posuw (f _z) : _____ mm/ząb	
<hr/>		
5. Obrabiarka : _____	<input type="checkbox"/> Chłodzenie wewnętrzne	
Układ pracy : <input type="checkbox"/> układ poziomy <input type="checkbox"/> układ pionowy	Zamocowanie narzędzia : <input type="checkbox"/> Tulejka <input type="checkbox"/> Weldon / Whistle Notch	
	<input type="checkbox"/> Oprawka hydrauliczna <input type="checkbox"/> Mocowanie termiczne	
<hr/>		
6. Chłodziwo : <input type="checkbox"/> Emulsja <input type="checkbox"/> Olej <input type="checkbox"/> Powietrze <input type="checkbox"/> Mgła olejowa		
Produkt : _____		
<hr/>		
7. Powód zmiany narzędzia : <input type="checkbox"/> Zużycie narzędzia <input type="checkbox"/> Zniszczenie narzędzia		
<input type="checkbox"/> Gwint wykonany nieprawidłowo (sprawdzony sprawdzianem)	<input type="checkbox"/> Błąd programu	
<hr/>		
8. Porównanie wydajności		
Narzędzie w trakcie testów : _____		
Wyniki i obserwacje : _____		

<hr/>		
Uwagi : _____		

УСЛОВИЯ ПОСТАВКИ И ОПЛАТЫ

Заказы	По заказам, которые не могут быть отгружены немедленно, будут сообщены сроки поставки. На изделия, которые более не относятся к стандартной программе, но присутствуют в каталоге, цены будут указаны как на „специальные“. Заказ может быть аннулирован только совместным письменным соглашением.
Ценовые предложения и уведомления	По причине постоянного развития все характеристики, упомянутые в наших предложениях, приложениях, указаниях весов, измерений, также как и иллюстрации и чертежи указывают приближенные значения. Эти технические данные имеют обязательное значение только там, где оговорено дополнительно.
Цены	Наши цены указаны при условиях поставки ex works Malleray, без учета НДС, упаковки, страховки, фрахта, таможенных и регистрационных сборов. В случае роста цен, мы оставляем за собой право выставить счета по уже измененным ценам.
Платежи	Платежи должны производиться в форме аванса или в форме безотзывного подтвержденного аккредитива открытого в нашу пользу в Швейцарском банке. Все банковские комиссии и сборы должны быть уплачены покупателем.
Право собственности	Мы оставляем за собой право собственности на все поставляемые товары до тех пор, пока цена продажи плюс побочные расходы не будут нам полностью оплачены покупателем.
Отгрузка	Все риски, связанные с поставкой, относятся на счет покупателя.
Поставка	Подтвержденные сроки поставки не являются обязывающими. Мы сделаем все от нас зависящее, чтобы выдержать их. Однако мы не можем нести ответственности за прямые или косвенные потери, возникшие по причине задержки поставки.
Специальные заказы	При исполнении специальных заказов мы оставляем за собой право на количественные колебания изделий в пределах 15 %, или при небольших заказах 1 или 2 штуки.
Гарантии	Инструменты, признанные бракованными по вине DC будут заменены бесплатно, но без возмещения каких бы то ни было прочих убытков.
Претензии	Претензии принимаются в течение 15 дней с даты получения товара.
Чертежи и эскизы	Воспроизведение или передача чертежей и прочих документов третьим сторонам запрещены. Информация (чертежи и иллюстрации) в нашем каталоге являются информационными но не обязательными.
Специальные условия	В случае частичной или полной остановки нашего производства мы оставляем за собой право частично или полностью отказаться от обязательств по поставке.
Арбитраж	Все споры разрешаются в соответствии со Швейцарским законодательством. Местонахождение арбитражного суда – Мотье (Moutier), Швейцария.

DOSTAWA I WARUNKI PŁATNOŚCI DC SWISS

Zamówienia	Zamówienia, które nie mogą być zrealizowane z magazynu będą potwierdzone. Narzędzia, które nie należą już do programu standardowego, mimo że nadal występują w katalogu, będą fakturowane jako „specjalne”. Zamówienia mogą zostać anulowane na podstawie wzajemnych pisemnych ustaleń.
Oferty i potwierdzenia	Ze względu na ciągły rozwój, wszelkie informacje zawarte w ofertach (opisy, załączniki, wymiary, wagi oraz rysunki) są przybliżone. Tego typu dane techniczne można traktować jako wiążące tylko wówczas, gdy zostały jasno sprecyzowane.
Ceny	Oferowane przez nas ceny dotyczą dostaw „ex works” Malleray i nie zawierają podatku VAT, pakowania, ubezpieczenia, kosztów przesyłki oraz odpraw celnych. W przypadku wzrostu cen, zastrzegamy sobie prawo do fakturowania narzędzi już potwierdzonych zgodnie z nowym cennikiem.
Płatność	Płatności muszą być dokonane z góry lub na podstawie nieodwołalnej i potwierdzonej akredytywy dokumentowej, otwartej na naszą korzyść w banku Swiss. Wszystkie opłaty bankowe ponosi kupujący.
Prawo własności	Zastrzegamy sobie prawo własności w stosunku do wszystkich dostarczonych towarów do momentu dokonania pełnej płatności z uwzględnieniem wszelkich kosztów dodatkowych.
Przesyłka	Przesyłki są dokonywane na ryzyko nabywcy.
Dostawa	Potwierdzone terminy dostaw nie są wiążące. Zrobimy wszystko co w naszej mocy, aby je utrzymać. Jednakże nie ponosimy odpowiedzialności za ewentualne straty wynikłe bezpośrednio lub pośrednio z powodu opóźnionych dostaw.
Zamówienia specjalne	Dla wszystkich narzędzi specjalnych zastrzegamy sobie prawo do dostaw pomniejszonych lub powiększonych o 15% w stosunku do zamówionej ilości (w przypadku małych ilości o 1 lub 2 szt.).
Gwarancja	Narzędzia uznane przez DC za wadliwe będą wymienione bezpłatnie lecz bez wcześniejszego powiadomienia.
Reklamacje	Reklamacje będą rozpatrzone w ciągu 15 dni od daty dostarczenia wadliwego towaru.
Rysunki i szkice	Kopiowanie lub przekazywanie rysunków i dokumentów osobom trzecim jest zabronione. Informacje (rysunki i wydruki) zamieszczone w katalogu mają charakter pomocniczy i nie są wiążące.
Warunki specjalne	W przypadku częściowego lub całkowitego wstrzymania procesu produkcyjnego, zastrzegamy sobie prawo do częściowego lub całkowitego anulowania zobowiązań wynikających ze złożonych zamówień.
Regulacje prawne	Powyższe kwestie są regulowane przez prawo szwajcarskie z siedzibą sądu w Moutier (Szwajcaria).

ЦЕНОВЫЕ ДОПОЛНЕНИЯ – DODATKOWE OPŁATY

Изменения цен при модификациях и дополнительной обработке поверхности

	К цене за штуку брутто	К прайс-листу каждый типоразмер (нетто)
Изменение угла заточки (Ø 5 - 20 мм)	10 %	по запросу
Удлинение заходной части (до Ø 20 мм)	10 %	по запросу
Укорачивание заходной части (Ø 5 - 20 мм)	20 %	по запросу
Вышлифовка стружколомающей фаски (Ø 5 - 20 мм)	10 %	по запросу
Удаление центрального конуса	3 %	по запросу
Увеличенное стружечное пространство от Ø 4 мм	12 %	по запросу
Азотирование	10 %	по запросу
DC „V” обработка поверхности	8 %	по запросу
Дополнительная маркировка	5 %	по запросу
Внутренний СОЖ, фронтальный выход	по запросу	по запросу
Внутренний СОЖ, радиальный выход	по запросу	по запросу
Покрyтия TiN, TiCN, VS, CrN, HL	по запросу	по запросу

Dodatkowe opłaty za modyfikacje oraz obróbkę powierzchni

	Do każdej ceny brutto	Partycypacja w kosztach ustawczych wg typu i rozmiaru (netto)
Modyfikacja kąta natarcia (Ø 5 - 20 mm)	10 %	na życzenie
Wydłużenie nakroju (do Ø 20 mm)	10 %	na życzenie
Skrócenie nakroju (Ø 5 - 20 mm)	20 %	na życzenie
Ostrzenie narzynki (Ø 5 - 20 mm)	10 %	na życzenie
Usuwanie przeciwnakiełka	3 %	na życzenie
Nakrój obniżony od Ø 4 mm	12 %	na życzenie
Azotowanie	10 %	na życzenie
DC „V” – waporyzacja	8 %	na życzenie
Dodatkowe cechowanie	5 %	na życzenie
Wew. chłodzenie, wyjście centralne	na życzenie	na życzenie
Wew. chłodzenie, wyjście promieniowe	na życzenie	na życzenie
Powłoki TiN, TiCN, VS, CrN, HL	na życzenie	na życzenie

Цены на поверочные сертификаты резьбовых калибров – Ceny za certyfikaty sprawdzianów

На вновь заказанные резьбовые калибры / Pogrešność измерений U95

Dla nowo zamówionych sprawdzianów / Błąd pomiaru wynosi U95

			Цены нетто / Ceny netto
D5703	D5725	Ø 1 - 2.9 mm Ø 3 - 40 mm	по запросу / на życzenie по запросу / на życzenie
D5701-1	D5701-2	Ø 1 - 2.9 mm Ø 3 - 40 mm Ø 41 - 80 mm Ø 81 - 200 mm	по запросу / на życzenie по запросу / на życzenie по запросу / на życzenie по запросу / на życzenie
D5704	D5714	Ø 1 - 2.9 mm Ø 3 - 40 mm Ø 41 - 80 mm Ø 81 - 200 mm	по запросу / на życzenie по запросу / на życzenie по запросу / на życzenie по запросу / на życzenie
D5720 / D5721	D5722 / D5723	Ø 3 - 40 mm Ø 41 - 80 mm Ø > 80 mm	по запросу / на życzenie по запросу / на życzenie по запросу / на życzenie

Все „сертифицированные” калибры будут маркированы идентификационным номером соответствующего сертификата.

Wszystkie „certyfikowane” sprawdziany będą cechowane numerem identyfikacyjnym odpowiadającym certyfikatowi.



www.dcswiss.com

- **eCatalogue**
- **eAssistant**
- **dxfl Download**

DC SWISS SA

CH-2735 Malleray

Tel. +41 32 491 63 63

Fax +41 32 491 64 64

E-mail: info@dcswiss.ch

DC SWISS SA

CH-2735 Malleray
Tel. +41 32 491 63 63
Fax +41 32 491 64 64
E-mail: info@dcswiss.ch

DC SWISS GmbH

Graseggerstraße 125
DE-50737 Köln
Tel. +49 221 995 532-0
Fax +49 221 995 532-10
E-Mail: info@dcswiss.de

DC SWISS s.r.l.



Via Canova 10
IT-20017 Rho
Tel. +39 02 669 40 41
Fax +39 02 669 78 50
E-mail: info@dcswiss.it

Предупреждение

Резьбонарезные инструменты могут сломаться как по причине технического характера, так и допущенной небрежности и причинить вред здоровью оператора. Всегда соблюдайте правила техники безопасности, использование очков является обязательным. Заточка инструмента образует вредные частицы, поэтому должна выполняться только в соответствии с жесткими стандартами техники безопасности.

Uwaga

Narzędzia do gwintowania mogą pękać lub ulegać zniszczeniu zarówno w wyniku usterek technicznych, jak i poprzez zaniedbania, co w efekcie może narazić na niebezpieczeństwo zdrowie operatora. Szlifowanie narzędzi do gwintowania musi być wykonywane z zachowaniem najwyższych norm bezpieczeństwa.

 Представитель и Дистрибьютер :
Przedstawiciel i Dystrybutor 



ООО «МВМ Инжиниринг»

Россия, 123007 Москва, Хорошевское шоссе, 32А

Тел: +7 495 723 74 48

Факс: +7 495 647 26 90

Internet: www.mwm-eng.ru

E-mail: sales@mwm-eng.ru

DC SWISS SA

CH-2735 Malleray

Tel. +41 32 491 63 63

Fax +41 32 491 64 64

E-mail: info@dcswiss.ch



**THREADING
TECHNOLOGY**

www.dcswiss.com